



**ZNEO32! Family of Microcontrollers**

**Z32F0642 Evaluation Kit**

**User Manual**

UM028401-0317

**ZNEO32!**  
*32 Bit Microcontrollers*



**Warning:** DO NOT USE THIS PRODUCT IN LIFE SUPPORT SYSTEMS.

---

## LIFE SUPPORT POLICY

ZILOG'S PRODUCTS ARE NOT AUTHORIZED FOR USE AS CRITICAL COMPONENTS IN LIFE SUPPORT DEVICES OR SYSTEMS WITHOUT THE EXPRESS PRIOR WRITTEN APPROVAL OF THE PRESIDENT AND GENERAL COUNSEL OF ZILOG CORPORATION.

### As used herein

Life support devices or systems are devices which (a) are intended for surgical implant into the body, or (b) support or sustain life and whose failure to perform when properly used in accordance with instructions for use provided in the labeling can be reasonably expected to result in a significant injury to the user. A critical component is any component in a life support device or system whose failure to perform can be reasonably expected to cause the failure of the life support device or system or to affect its safety or effectiveness.

### Document Disclaimer

©2017 Zilog, Inc. All rights reserved. Information in this publication concerning the devices, applications, or technology described is intended to suggest possible uses and may be superseded. ZILOG, INC. DOES NOT ASSUME LIABILITY FOR OR PROVIDE A REPRESENTATION OF ACCURACY OF THE INFORMATION, DEVICES, OR TECHNOLOGY DESCRIBED IN THIS DOCUMENT. ZILOG ALSO DOES NOT ASSUME LIABILITY FOR INTELLECTUAL PROPERTY INFRINGEMENT RELATED IN ANY MANNER TO USE OF INFORMATION, DEVICES, OR TECHNOLOGY DESCRIBED HEREIN OR OTHERWISE. The information contained within this document has been verified according to the general principles of electrical and mechanical engineering.

ZNEO32! is a trademark or registered trademark of Zilog, Inc. All other product or service names are the property of their respective owners.

## Revision History

Each instance in this document's revision history reflects a change from its previous edition. To learn more, refer to the corresponding page(s) or appropriate links furnished in the table below.

<b>Date</b>	<b>Revision Level</b>	<b>Description</b>	<b>Page</b>
Mar 2017	01	Original issue.	n/a

## Overview

Zilog's Z32F0642 Evaluation Kit (part number Z32F0642100KITG) enables developers to start programming projects using the Z32F0642 microcontroller, a member of the ZNEO32! Family of MCUs. The kit exposes the ports to allow them to be connected by the user for prototyping and creating proofs of concept.

This Evaluation Kit consists of 5 LEDs, 2 switches, and a USB-to-UART connection for serial communications and powering. The board also includes a standard 20-pin JTAG header.

This user manual provides a description of the Z32F0642 Evaluation Board. It includes features of the Z32F0642 MCU, schematic diagrams of the board, and kit contents and requirements.

## Kit Contents

The Z32F0642 Evaluation Kit contains the following items:

- 1 Z32F0642 Evaluation Board
- 1 A (male) to Mini-B USB cable
- 1 ZNEO32! Evaluation Kit flyer

Additional requirements (to be obtained by user):

- JTAG Debugger tool
- Cortex M0 development tools, such as Keil  $\mu$ Vision 5 or IAR Embedded workbench for ARM
- Zilog CMSIS Pack file, available at [www.zilog.com](http://www.zilog.com)
- Z32F0642 MCU product specification ([PS0392](#)), available from the Zilog website.

Figure 1 shows the contents of the Z32F0642 Evaluation Kit.



Figure 1. The Z32F0642 Evaluation Kit

## Z32F0642 MCU Features

Key features of the Z32F0642 MCU include:

- High performance low-power Cortex-M0 core
- 64KB code Flash memory
  - Endurance: 10,000 times at room temperature
  - Retention: 10 years
- 4KB SRAM
- General Purpose I/O (GPIO)
  - 44 ports (PA[15:0], PB[7:0], PC[15:0], PD[3:0]) : 48-Pin
  - 30 Ports (PA[9:0], PB[7:0], PC[1:0], PC[8:7], PC[15:10], PD[3:2]) : 32-Pin
- 3-Phase Motor PWM (MPWM) with ADC triggering function: 1 channel
- 1MSPS high-speed 12-bit ADC with sequential conversion function
  - 12-channel: 48-pin
  - 10-channel: 32-pin
- Timer: 16-bit 4-channel
- Free Run Timer (FRT): 32-bit 1-channel
- Watchdog Timer (WDT): 32-bit 1-channel
- External communication ports:
  - 2-channel UARTS
  - 1-channel I<sup>2</sup>C
  - 1-channel SPI
- System fail-safe function by clock monitoring
- XTAL OSC fail monitoring
- Power on reset
- Programmable low voltage detector (brown-out detector)
- Debug and emergency stop function
- SWD debugger
- Supports UART and SPI ISP
- Power Down mode: IDLE, STOP1, STOP2 modes
- Sub-active mode: External 32.768 kHz crystal or Internal 40 kHz LSI
- Operating frequency

- 40 kHz–40 MHz
- External 32.768 kHz crystal
- Operating voltage: 2.2V ~ 5.5V
- Two package options: LQFP-32, LQFP-48

To learn more about the Z32F0642 MCU, refer to the Z32F0642 MCU Product Specification ([PS0392](#)).

## Mini Board

Figure 2 shows the Mini Board and Table 1 lists its characteristics.



Figure 2. Mini Board



**Table 1. Mini Board Characteristics**

Contents	Main Characteristics	Note
MCU	Z32F06423AKE	ARM Cortex M0
Operating clock	16MHz	Crystal
ROM	64KB Flash ROM	
RAM	4KB	
Communication port	USB to UART port	Mini-B USB connector
Debugging port	SWD	20-pin connector
Input buttons	1 reset, 1 AUX	Tactile switch

Figure 3 displays the Mini Board MCU’s external pin connections.

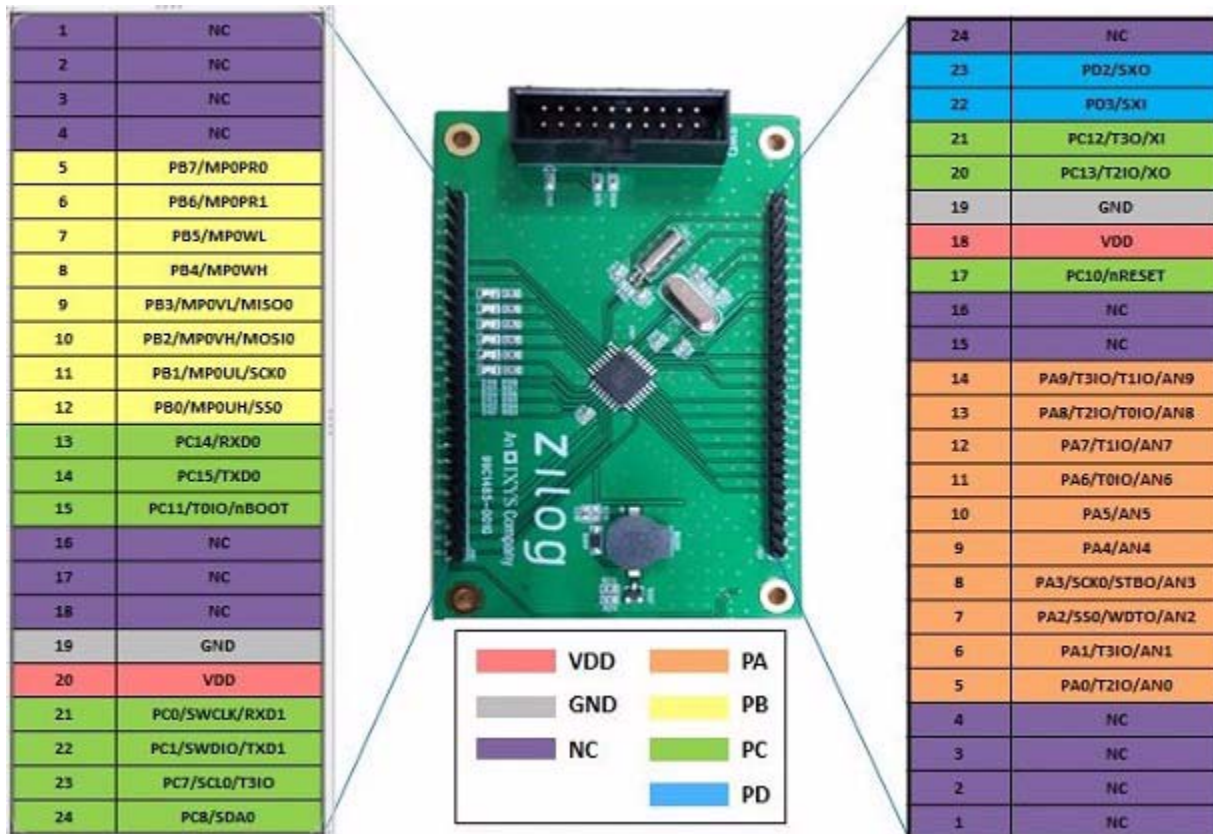

**Figure 3. Mini Board MCU’s External Pin Connections**



The jumper settings are shown in Figure 4.

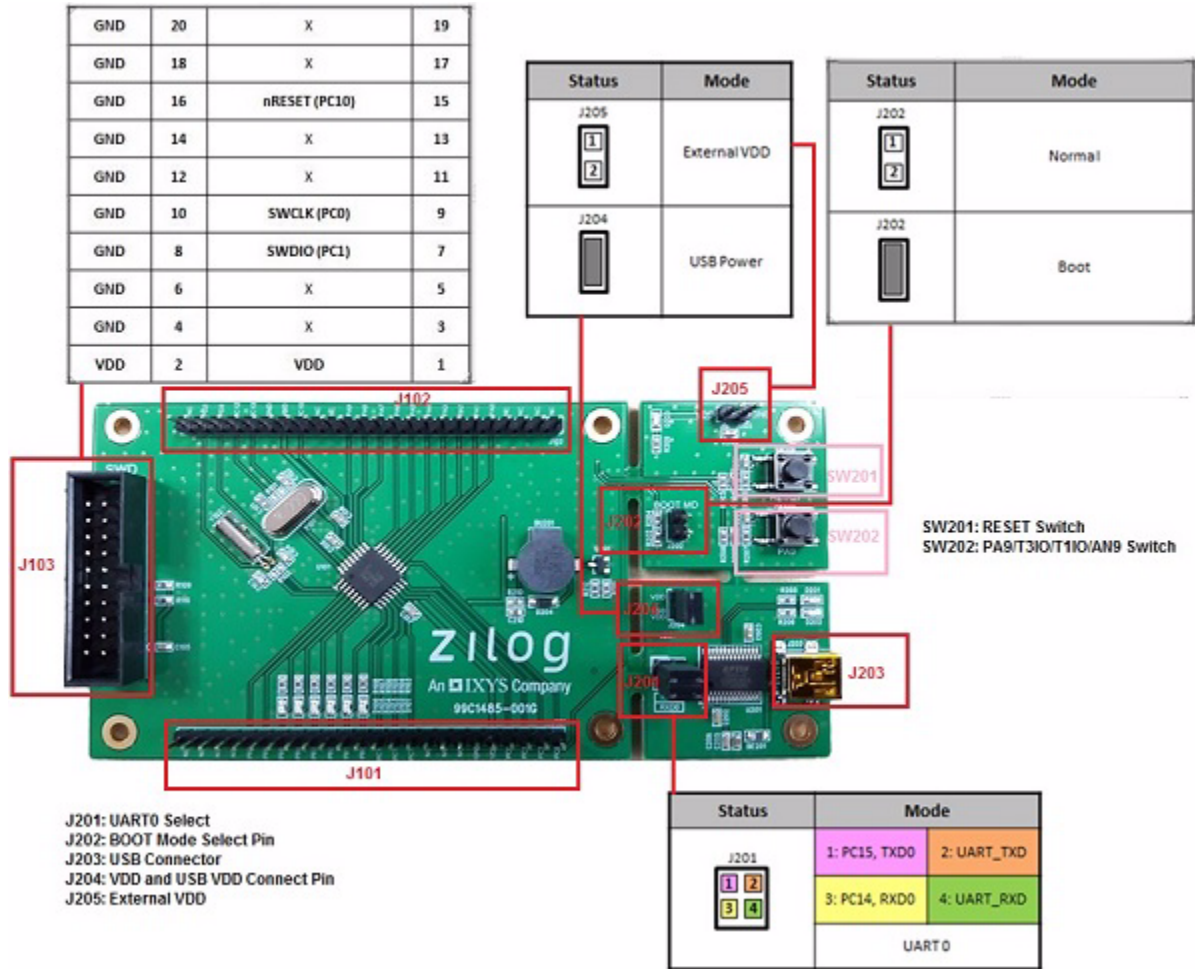

Figure 4. Jumper Settings

## Z32F0642 Evaluation Kit Documentation

The documents associated with the Z32F0642 Evaluation Kit are listed in Table 2. Each of these documents can be obtained from the Zilog website by clicking the link associated with its Document Number.

**Table 2. Z32F0642 Evaluation Kit Documentation**

<b>Document</b>	<b>Description</b>
<a href="#">UM0284</a>	Z32F0642 Evaluation Kit User Manual
<a href="#">PS0392</a>	Z32F0642 Product Specification
<a href="#">FL0189</a>	ZNEO32! M0/M0+ Evaluation Kit Flyer

# Appendix A. Schematic Diagrams

Figures 5 and 6 present schematic diagrams of the Z32F0642 Evaluation Board with the 32-pin LQFP package MCU.

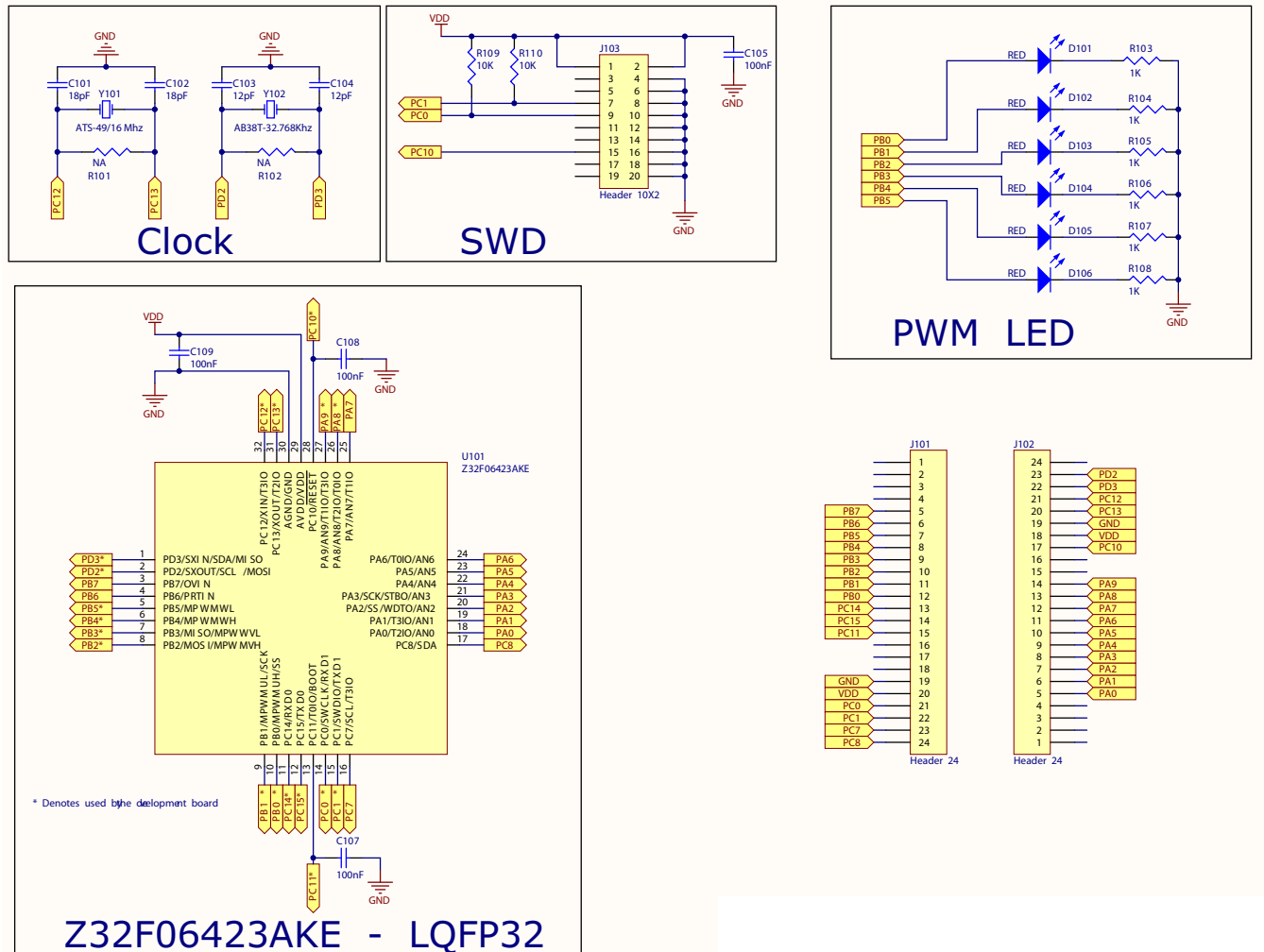

Figure 5. Z32F0642 Evaluation Board Schematic Diagram, #1 of 2

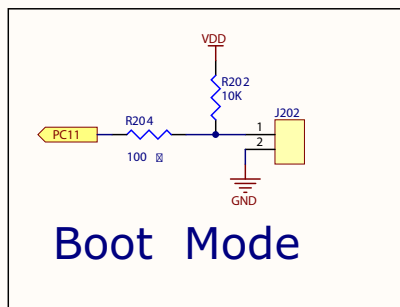
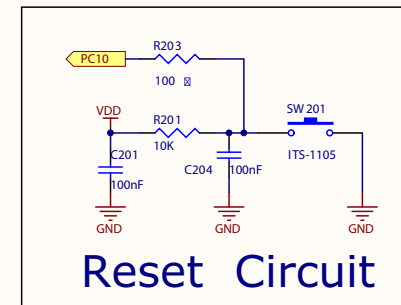
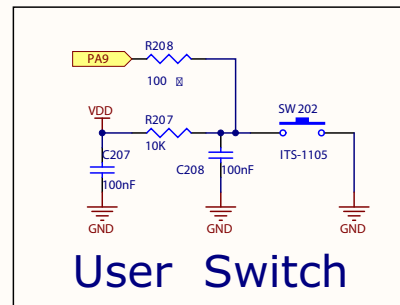
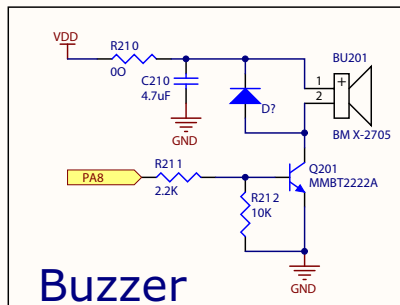
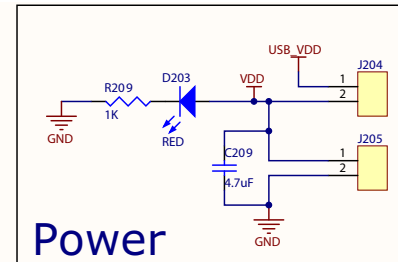
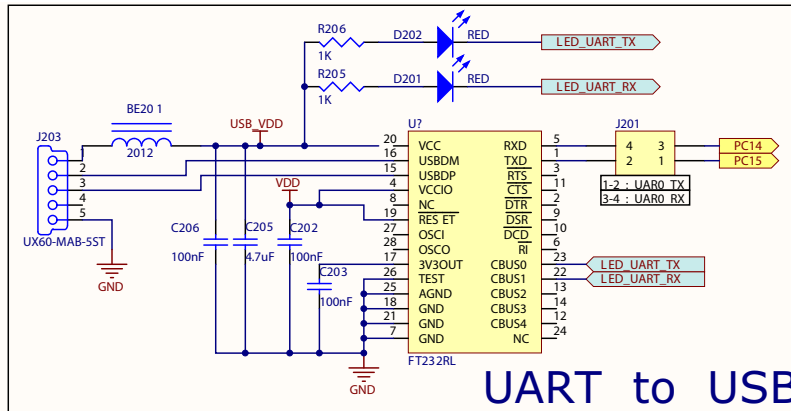

Figure 6. Z32F0642 Evaluation Board Schematic Diagram, #2 of 2

## Customer Support

To share comments, get your technical questions answered, or report issues you may be experiencing with our products, please visit Zilog's Technical Support page at <http://support.zilog.com>.

To learn more about this product, find additional documentation, or to discover other facets about Zilog product offerings, please visit the [Zilog Knowledge Base](#) or consider participating in the [Zilog Forum](#).

This publication is subject to replacement by a later edition. To determine whether a later edition exists, please visit the Zilog website at <http://www.zilog.com/>