

DMG3407SSN

P-CHANNEL ENHANCEMENT MODE MOSFET

Product Summary

$V_{(BR)DSS}$	$R_{DS(ON)}$	I_D $T_A = 25^\circ C$
-30V	50mΩ @ $V_{GS} = -10V$	-4.0A
	72mΩ @ $V_{GS} = -4.5V$	-3.3A

Features and Benefits

- Low On-Resistance
- Low Input Capacitance
- Fast Switching Speed
- Low Input/Output Leakage
- **Lead-Free Finish; RoHS compliant (Note 1)**
- **Halogen and Antimony Free. "Green" Device (Note 2)**
- **Qualified to AEC-Q101 Standards for High Reliability**

Description and Applications

This new generation MOSFET has been designed to minimize the on-state resistance ($R_{DS(on)}$) and yet maintain superior switching performance, making it ideal for high efficiency power management applications.

- Load Switch
- DC-DC Converters
- Power management functions

Mechanical Data

- Case: SC59
- Case Material – Molded Plastic. UL Flammability Rating 94V-0
- Moisture Sensitivity: Level 1 per J-STD-020
- Terminals: Finish - Matte Tin Solderable per MIL-STD-202, Method 208
- Terminal Connections: See Diagram
- Weight: 0.014 grams (approximate)

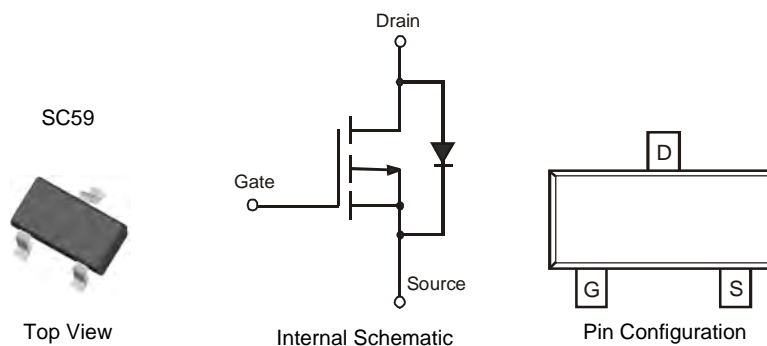

Ordering Information (Note 3)

Part Number	Case	Packaging
DMG3407SSN-7	SC59	3000 / Tape & Reel

Notes: 1. EU Directive 2002/95/EC (RoHS) & 2011/65/EU (RoHS 2) compliant. No purposely added lead. Halogen and Antimony free

Marking Information

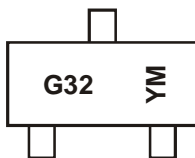

G32 = Product Type Marking Code
 YM = Date Code Marking
 Y = Year (ex: X = 2010)
 M = Month (ex: 9 = September)

Date Code Key

Year	2010	2011	2012	2013	2014	2015	2016
Code	X	Y	Z	A	B	C	D

Month	Jan	Feb	Mar	Apr	May	Jun	Jul	Aug	Sep	Oct	Nov	Dec
Code	1	2	3	4	5	6	7	8	9	O	N	D

Maximum Ratings @T_A = 25°C unless otherwise specified

Characteristic			Symbol	Value	Units
Drain-Source Voltage			V _{DSS}	-30	V
Gate-Source Voltage			V _{GSS}	±20	V
Continuous Drain Current (Note 5) V _{GS} = -10V	Steady State	T _A = 25°C T _A = 70°C	I _D	-4.0 -3.2	A
	t<10s	T _A = 25°C T _A = 70°C	I _D	-4.6 -3.6	A
Continuous Drain Current (Note 5) V _{GS} = -4.5V	Steady State	T _A = 25°C T _A = 70°C	I _D	-3.3 -2.6	A
	t<10s	T _A = 25°C T _A = 70°C	I _D	-3.9 -3.1	A
Pulsed Drain Current (10µs pulse, duty cycle = 1%)			I _{DM}	-30	A
Maximum Body Diode Forward Current (Note 5)			I _S	-2.0	A

Thermal Characteristics @T_A = 25°C unless otherwise specified

Characteristic		Symbol	Value	Units
Total Power Dissipation (Note 4)	T _A = 25°C	P _D	1.1	W
	T _A = 70°C		0.7	
Thermal Resistance, Junction to Ambient (Note 4)	Steady state	R _{θJA}	166	°C/W
	t<10s		118	
Total Power Dissipation (Note 5)	T _A = 25°C	P _D	1.8	W
	T _A = 70°C		1.1	
Thermal Resistance, Junction to Ambient (Note 5)	Steady state	R _{θJA}	98	°C/W
	t<10s		71	
Thermal Resistance, Junction to Case (Note 5)		R _{θJC}	18	
Operating and Storage Temperature Range		T _J , T _{STG}	-55 to +150	°C

Electrical Characteristics @ T_A = 25°C unless otherwise stated

Characteristic	Symbol	Min	Typ	Max	Unit	Test Condition
OFF CHARACTERISTICS (Note 6)						
Drain-Source Breakdown Voltage	BV _{DSS}	-30	-	-	V	V _{GS} = 0V, I _D = -250µA
Zero Gate Voltage Drain Current T _J = 25°C	I _{DSS}	-	-	-1	µA	V _{DS} = -30V, V _{GS} = 0V
Gate-Source Leakage	I _{GSS}	-	-	±100	nA	V _{GS} = ±20V, V _{DS} = 0V
ON CHARACTERISTICS (Note 6)						
Gate Threshold Voltage	V _{GS(th)}	-1.0	-1.5	-2.1	V	V _{DS} = V _{GS} , I _D = -250µA
Static Drain-Source On-Resistance	R _{DS(on)}	-	39	50	mΩ	V _{GS} = -10V, I _D = -4.1A
		-	56	72		V _{GS} = -4.5V, I _D = -3.0A
Forward Transfer Admittance	Y _{fs}	-	8.2	-	S	V _{DS} = -5V, I _D = -4A
Diode Forward Voltage	V _{SD}	-	-0.75	-1.1	V	V _{GS} = 0V, I _S = -1A
DYNAMIC CHARACTERISTICS (Note 7)						
Input Capacitance	C _{iss}	466	582	700	pF	V _{DS} = -15V, V _{GS} = 0V, f = 1.0MHz
Output Capacitance	C _{oss}	80	114	148		
Reverse Transfer Capacitance	C _{riss}	47	76	105		
Gate Resistance	R _g	2	5	8	Ω	V _{DS} = 0V, V _{GS} = 0V, f = 1MHz
Total Gate Charge	Q _g	10.6	13.3	16	nC	V _{GS} = -10V, V _{DS} = -15V, I _D = -4A
Total Gate Charge	Q _g	5.2	6.5	8.5		
Gate-Source Charge	Q _{gs}	1.3	1.7	2		
Gate-Drain Charge	Q _{gd}	1.1	1.9	2.7		
Turn-On Delay Time	t _{D(on)}	-	6.0	-	ns	V _{GS} = -10V, V _{DS} = -15V, R _L = 3.6Ω, R _G = 3Ω
Turn-On Rise Time	t _r	-	12.9	-		
Turn-Off Delay Time	t _{D(off)}	-	35.4	-		
Turn-Off Fall Time	t _f	-	30.7	-		
Reverse Recovery Time	t _{rr}	6.8	8.5	10.2	ns	I _F = 4A, di/dt = 100A/µs
Reverse Recovery Charge	Q _{rr}	5.5	7.0	8.5	nC	

- Notes:
2. Device mounted on FR-4 PCB with minimum recommended pad layout, single sided. The power dissipation P_D is based on t<10s R_{θJA}
 3. Device mounted on 1" x 1" FR-4 PCB with high coverage 2 oz. Copper, single sided. The power dissipation P_D is based on t<10s R_{θJA}
 4. Short duration pulse test used to minimize self-heating effect.
 5. Guaranteed by design. Not subject to production testing.