



**SMD LED**  
Product Data Sheet  
LTPA-S38FUMWE

Spec No. :

Created Date: 2016/09/30

Revision: (PRELIMINARY) – 1.2

**BNS-OD-FC001/A**

**SMD LED  
LTPA-S38FUMWE (PRELIMINARY)**

**SMD LED**

LTPA-S38FUMWE

<u>Rev</u>	<u>Description</u>	<u>By</u>	<u>Date</u>
1.0	New data sheet	Thomas	05/30/2016
1.1	Update 3.1	Thomas	09/30/2016
1.2	Update 1200mA for 5.4,5.5,5.6,5.7	Thomas	10/20/2016
<b>Above data for PD and Customer tracking only</b>			

**Customer Name:**

**Customer Signature:**

**Print Name:**

**LiteON Sales Signature:**

**Print Name:**

# SMD LED LTPA-S38FUMWE (PRELIMINARY)

## 1. Description

S3838 is a new small size high flux LED for slim designs. The black package stands for high stability.

### 1.1 Features

- Meet ROHS.
- SMD ceramic package.
- Package in 16mm tape on 7" diameter reels
- Preconditioning: accelerate to JEDEC level 2
- EIA STD package
- I.C. compatible
- Compatible with automatic placement equipment
- Compatible with infrared reflow solder process

### 1.2 Applications

- Aftermarket :accessary application

## 2. Package Dimensions

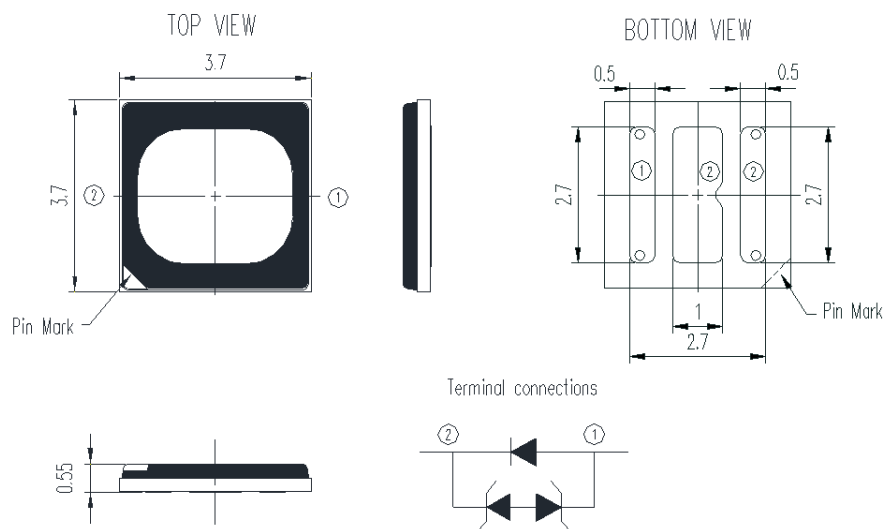

Part No.	Lens Color	Source Color
LTPA-S38FUMWE	Yellow	InGaN White

1. All dimensions are in millimeters and dimension tolerances are  $\pm 0.3\text{mm}$ .
2. Dimensions without tolerances are for reference only.

**SMD LED**  
**LTPA-S38FUMWE (PRELIMINARY)**

**3. Rating and Characteristics**

**3.1 Absolute Maximum Ratings at Ta=25°C**

Parameter	Symbol	Rating	Unit
Power Dissipation	P <sub>o</sub>	6	W
Min DC Forward Current	I <sub>F</sub>	50	mA
Max DC Forward Current	I <sub>F</sub>	1,200	mA
Peak Plus Current (1/100 duty cycle, 0.1ms pules width)	I <sub>p</sub>	2,000	mA
ESD Sensitivity(HBM)	V <sub>HBM</sub>	8	kV
Junction Temperature	T <sub>j</sub>	150	°C
Operating Temperature Range	T <sub>opr</sub>	-40°C~+125°C	°C
Storage Temperature Range	T <sub>stg</sub>	-40°C~+125°C	°C

**Notes :**

1. ESD spec is reference to AEC-Q101-001 HBM.
2. The unit of R<sub>th</sub> is °C/W electrical and driving current is 700mA.
3. The package LEDs are not designed to be driven in reverse bias.

## SMD LED LTPA-S38FUMWE (PRELIMINARY)

### 3.2 Electrical / Optical Characteristics at Ta=25°C

Parameter	Symbol	Values			Unit	Test Condition
		Min	Typ.	Max		
Correlated Color Temperature	CCT	--	6000	--	K	I <sub>F</sub> = 700mA
Color Rendering Index	CRI	--	70	--	-	
Viewing Angle	2θ <sub>1/2</sub>	--	120	--	deg	
Forward Voltage	V <sub>F</sub>	2.75	3.25	3.75	V	
Luminous Flux	Φ <sub>V</sub>	180		280	lm	
Thermal Resistance, Junction-Solder	R <sub>th, J-S</sub>		5.5		°C / W	

#### Notes

1. All of the VF value are typical and the real bin range please refer "VF Binning Parameter".
2. All of the Flux value are typical and the real Bin range please refer "Flux Binning Parameter".
3. Tolerance of Flux is ±10%, Tolerance of VF is ±5%, and tolerance of CRI is ±3.
4. Thermal resistance measurement tolerance is ± 10%, and with 11x 9 cm heat sink.
5. Reverse voltage(VR) condition is applied to IR test only. The device is not designed for reverse operation

# SMD LED LTPA-S38FUMWE (PRELIMINARY)

## 4. Bin Rank

Batch Description on Label: Vf / Iv / Color ( Ex. 8G/6N/57 )

### 4.1 VF Binning Parameter;

Forward Voltage		Unit : V@700mA	
Bin Code	Min.	Max.	
8E	2.75	3.00	
8F	3.00	3.25	
8G	3.25	3.50	
8H	3.50	3.75	

Tolerance on each Voltage bin is +/-0.1V

### 4.2 Flux Binning Parameter;

Luminous Flux		Unit : Im @700mA	
Bin Code	Min.	Max.	
5M	180	201	
6M	201	224	
7M	224	250	
8M	250	280	

Tolerance on each Intensity bin is +/-10%

# SMD LED LTPA-S38FUMWE (PRELIMINARY)

### 4.3 Color Rank

Color Bin Table						Test @700mA					
Bin Code	Color Bin Limits					Bin Code	Color Bin Limits				
	CIE-x	Point1	Point2	Point3	Point4		CIE-x	Point1	Point2	Point3	Point4
55	x	0.3241	0.3248	0.3350	0.3355	57	x	0.3190	0.3203	0.3298	0.3299
	y	0.3534	0.3370	0.3460	0.3633		y	0.3430	0.3274	0.3526	0.3361
60	x	0.3145	0.3163	0.3246	0.3253	65	x	0.3104	0.3127	0.3199	0.3212
	y	0.3330	0.3181	0.3424	0.3266		y	0.3234	0.3093	0.3325	0.3175

Tolerance on each Hue bin (x, y) bin is +/- 0.01.

### 4.4 Chromaticity Coordinate

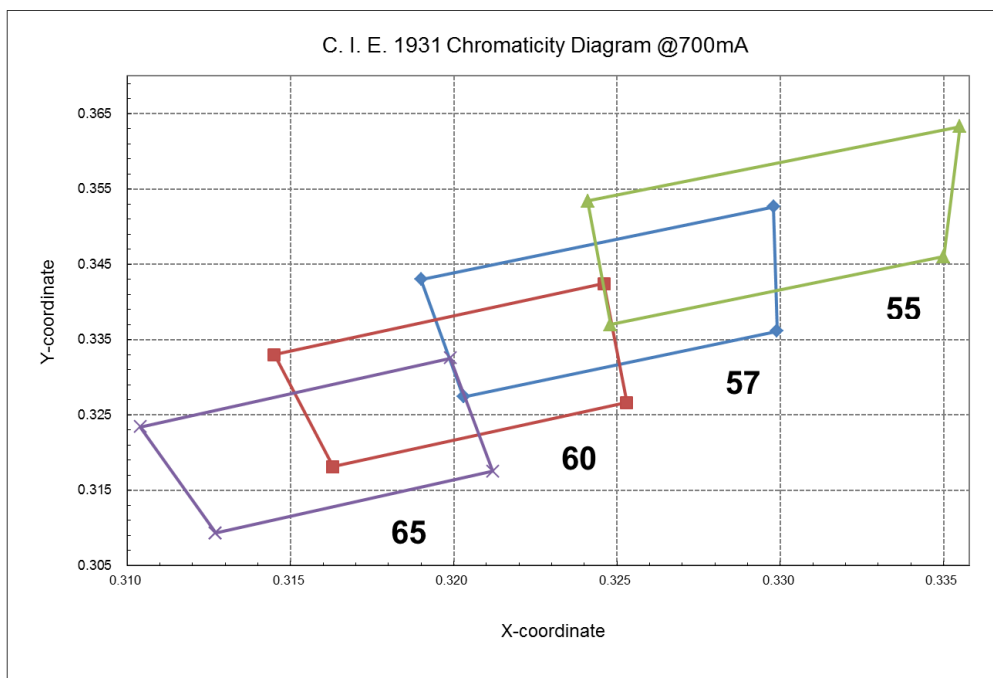

## SMD LED LTPA-S38FUMWE (PRELIMINARY)

### 5. Typical Electrical / Optical Characteristics Curves.

#### 5.1 Relative Spectral Power Distribution at 700mA, 25°C Ambient Temperature

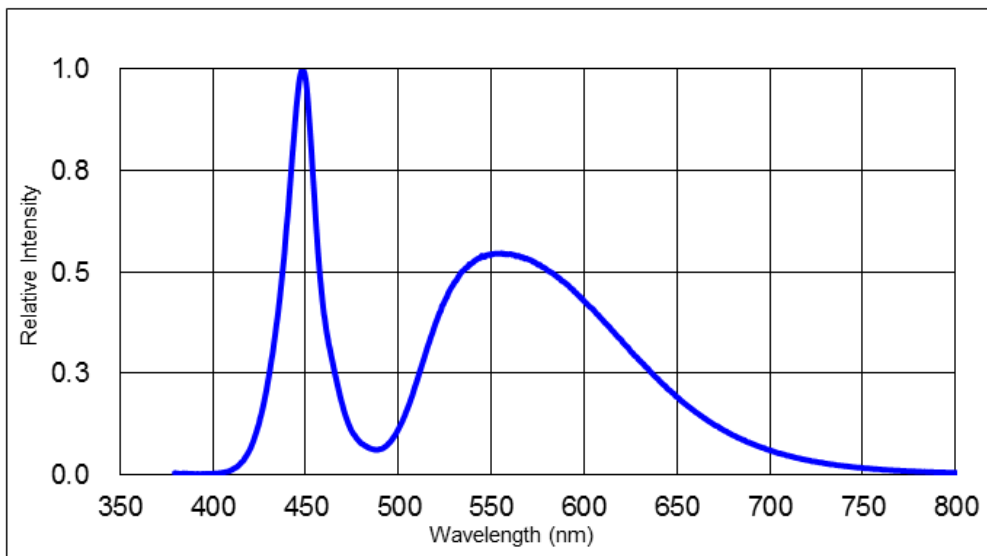

#### 5.2 Radiation Characteristics

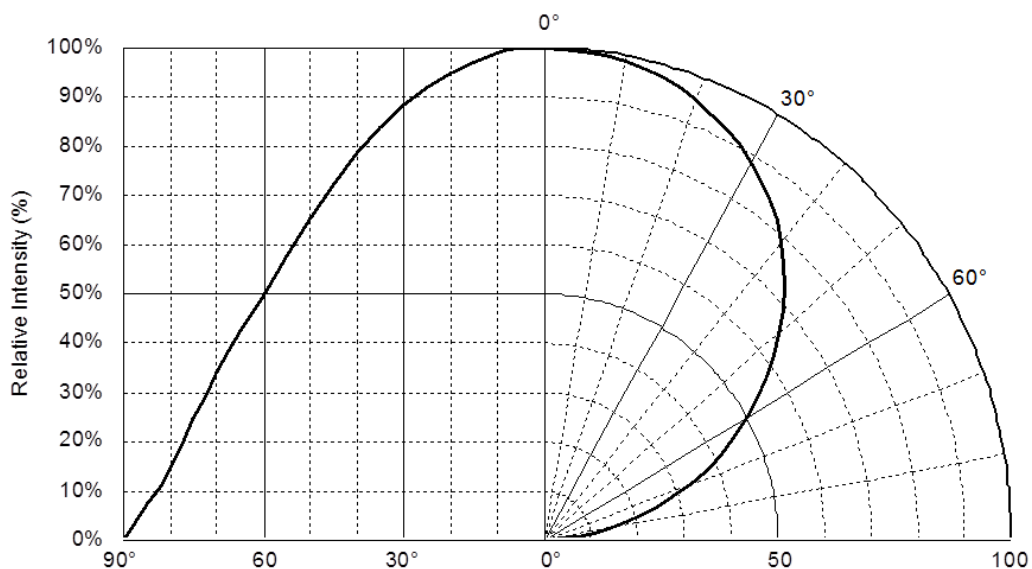



**SMD LED**  
**LTPA-S38FUMWE (PRELIMINARY)**

5.3 Maximum Forward Current vs. Ambient Temperature

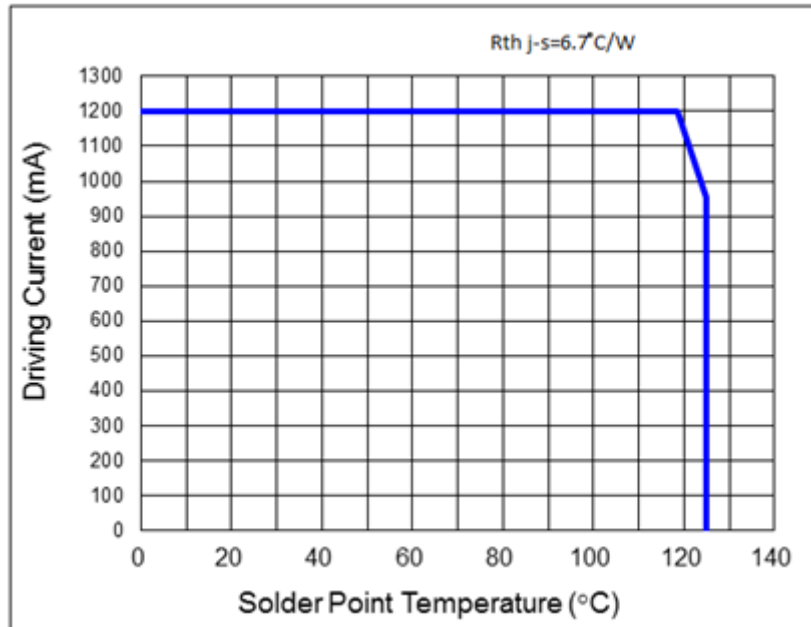

5.4 Forward Current vs. Forward Voltage at 25°C

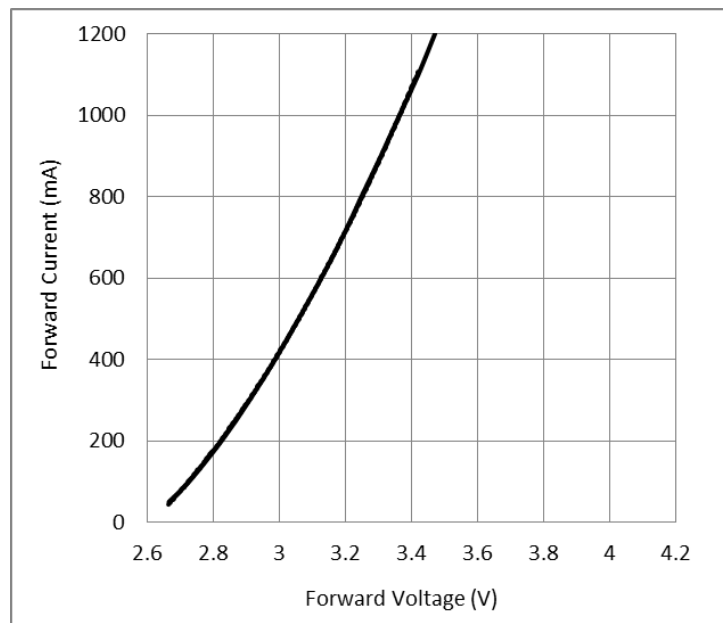

**SMD LED  
LTPA-S38FUMWE (PRELIMINARY)**

5.5 Relative CIE-x v.s. Forward Current at 25°C

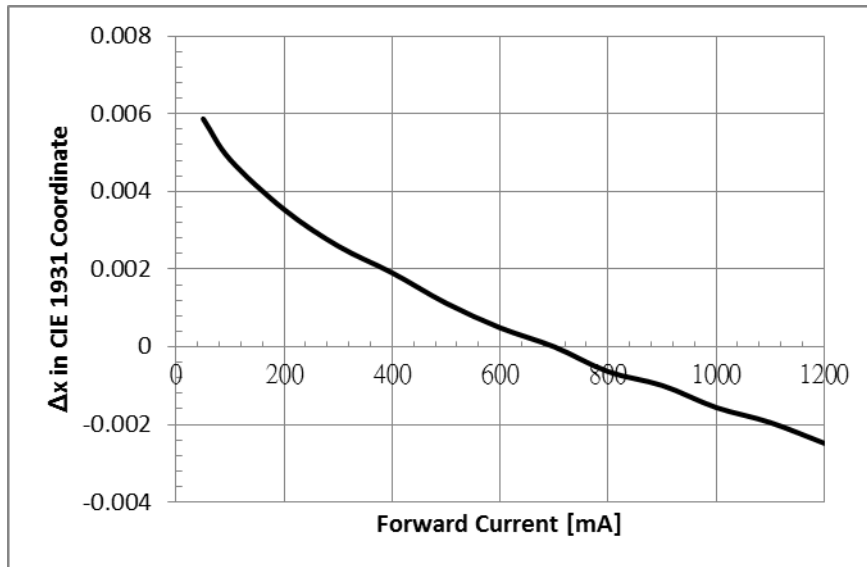

5.6 Relative CIE-y v.s. Forward Current at 25°C

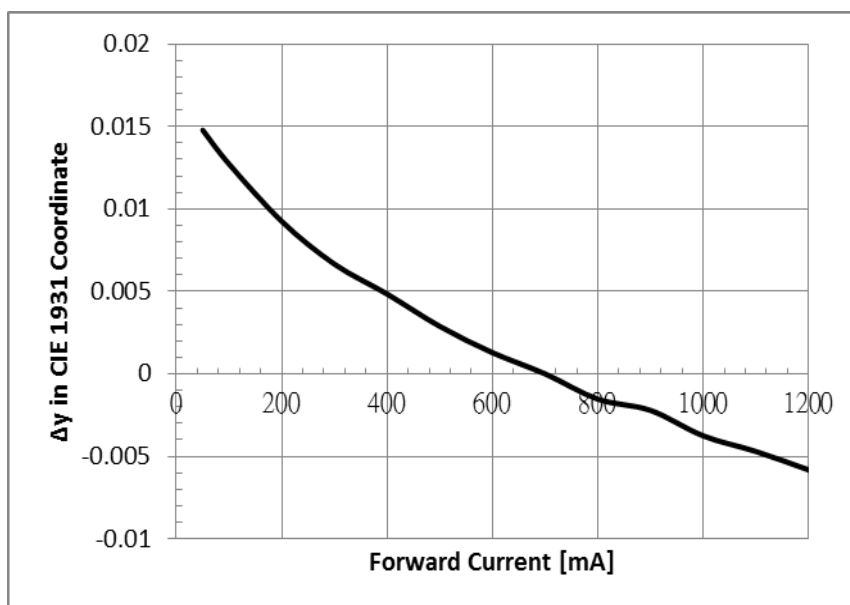

**SMD LED**  
**LTPA-S38FUMWE (PRELIMINARY)**

5.7 Relative Flux vs. Current

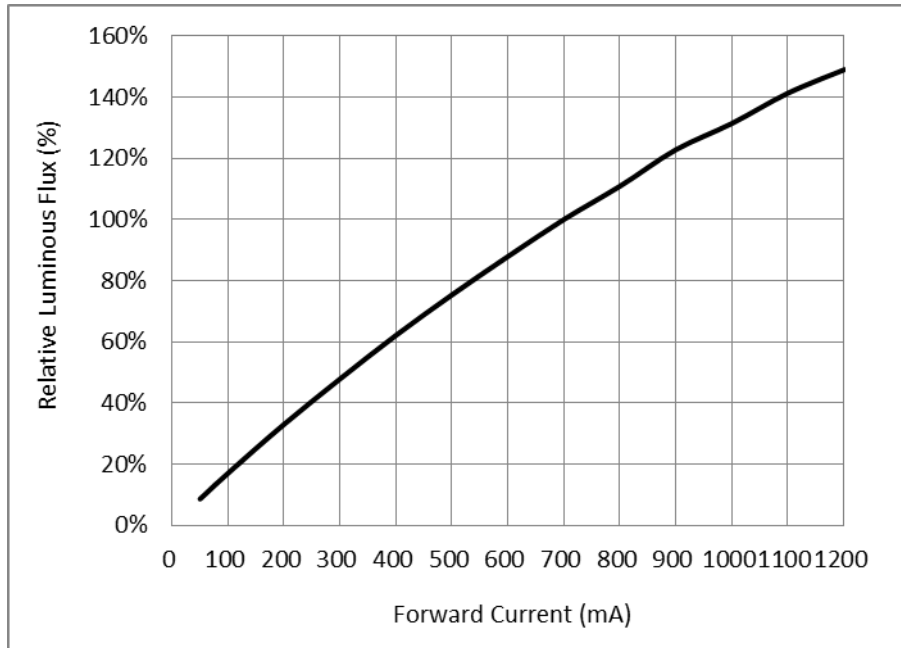

# SMD LED LTPA-S38FUMWE (PRELIMINARY)

## 6. Reflow Soldering Characteristics

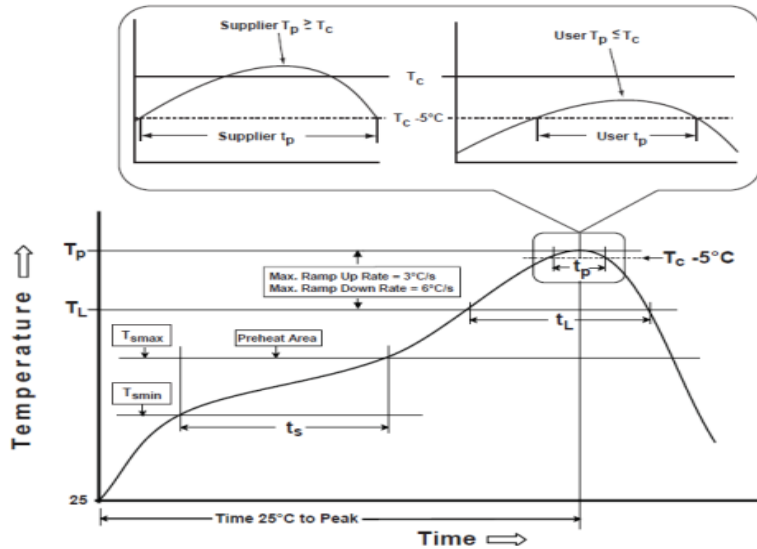

Profile Feature	Lead Free Assembly
Average Ramp-Up Rate ( $T_{Smax}$ to $T_P$ )	3°C / second max
Preheat Temperature Min ( $T_{Smin}$ )	150°C
Preheat Temperature Max ( $T_{Smax}$ )	200°C
Preheat Time ( $t_{Smin}$ to $t_{Smax}$ )	60 – 180 seconds
Time Maintained Above Temperature ( $T_L$ )	217°C
Time Maintained Above Time ( $t_L$ )	80 – 100 seconds
Peak / Classification Temperature ( $T_P$ )	260°C
Time Within 5°C of Actual Peak Temperature ( $t_p$ )	5 seconds
Ramp – Down Rate	6°C / second max
Time 25°C to Peak Temperature	8 minutes max

### Notes

- The LEDs can be soldered using the reflow soldering or hand soldering method. The recommended hand soldering condition is 350°C max. and 2secs max. for one time only, and the recommended reflow soldering condition is 260°C max. and 5secs max. for three times max.
- All temperatures refer to topside of the package, measured on the package body surface.

The soldering profile could be further referred to different soldering grease material characteristic. The grease vendor will provide this information.

**SMD LED**  
**LTPA-S38FUMWE (PRELIMINARY)**

**7. Package Dimensions of Tape and Reel**

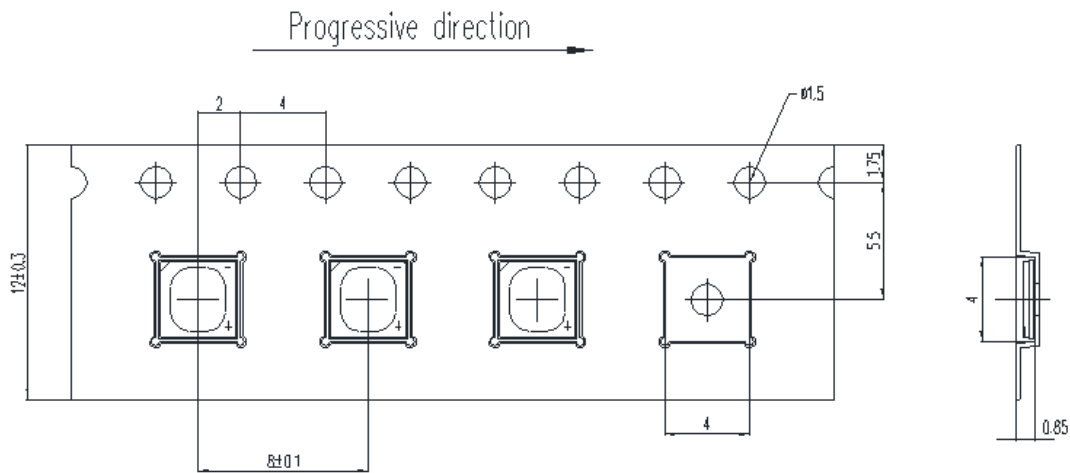

**8. Recommend Soldering Pad Layout**

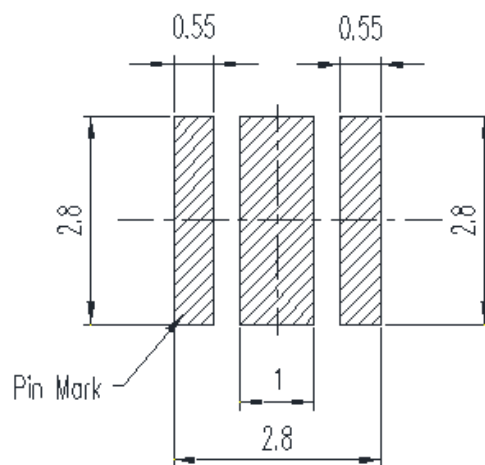

## SMD LED LTPA-S38FUMWE (PRELIMINARY)

### 9. Cautions

**9.1** An LED is a current-operated device. In order to ensure intensity uniformity on multiple LEDs connected in parallel in an application, it is recommended that a current limiting resistor be incorporated in the drive circuit, in series with each LED as shown in Circuit below.

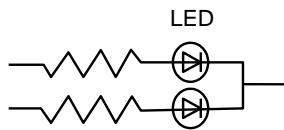

Circuit model A

(A) Recommended circuit.

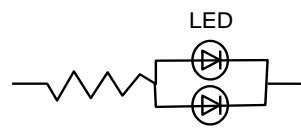

Circuit model B

(B) The brightness of each LED might appear different due to the differences in the I-V characteristics of those LEDs.

**9.2** Do not put any pressure on the light emitting surface either by finger or any hand tool and do not stack the COB products. Stress or pressure may cause damage to the wires of the LED array.

**9.3** This product is not designed for the use under any of the following conditions, please confirm the performance and reliability are well enough if you use it under any of the following conditions

- Do not use sulfur-containing materials in commercial products including the materials such as seals and adhesives that may contain sulfur.
- Do not put this product in a place with a lot of moisture (over 85% relative humidity), dew condensation, briny air, and corrosive gas (Cl, H<sub>2</sub>S, NH<sub>3</sub>, SO<sub>2</sub>, NO<sub>x</sub>, etc.), exposure to a corrosive environment may affect silver plating.

#### 9.4 ESD (Electrostatic Discharge)

Static Electricity or power surge will damage the LED. Suggestions to prevent ESD damage:

- Use of a conductive wrist band or anti-electrostatic glove when handling these LEDs.
- All devices, equipment, and machinery must be properly grounded.
- Work tables, storage racks, etc. should be properly grounded.
- Use ion blower to neutralize the static charge which might have built up on surface of the LED's plastic lens as a result of friction between LEDs during storage and handling.

ESD-damaged LEDs will exhibit abnormal characteristics such as high reverse leakage current, low forward voltage, or "no light up" at low currents.

To verify for ESD damage, check for "light up" and VF of the suspect LEDs at low currents.

## **SMD LED LTPA-S38FUMWE (PRELIMINARY)**

### **9.5 Storage**

- This product is qualified as Moisture sensitive Level 2 per JEDEC J-STD-020 Precaution when handling this moisture sensitive product is important to ensure the reliability of the product.
- The package is sealed: The LEDs should be stored at 30°C or less and 90%RH or less. And the LEDs are limited to use within one year, while the LEDs is packed in moisture-proof package with the desiccants inside.
- The package is opened:

The storage ambient for the LEDs should not exceed 30°C temperature or 60% relative humidity. It is recommended that LEDs out of their original packaging are IR-reflowed within one year. For extended storage out of their original packaging, it is recommended that the LEDs be stored in a sealed container with appropriate desiccant, or in a desiccators with nitrogen ambient. LEDs stored out of their original packaging for more than one year should be baked at about 60 deg C for at least 20 hours before solder assembly.