

Isc N-Channel MOSFET Transistor

IPD30N03S2L

• FEATURES

- With To-252(DPAK) package
- Low input capacitance and gate charge
- Low gate input resistance
- 100% avalanche tested
- Minimum Lot-to-Lot variations for robust device performance and reliable operation

• APPLICATIONS

- Switching applications
- Load switch
- Power management

• ABSOLUTE MAXIMUM RATINGS(T_a=25°C)

SYMBOL	PARAMETER	VALUE	UNIT
V _{DSS}	Drain-Source Voltage	30	V
V _{GSS}	Gate-Source Voltage	±20	V
I _D	Drain Current-Continuous	30	A
I _{DM}	Drain Current-Single Pulsed	120	A
P _D	Total Dissipation @T _c =25°C	136	W
T _j	Max. Operating Junction Temperature	175	°C
T _{stg}	Storage Temperature	-55~175	°C

• THERMAL CHARACTERISTICS

SYMBOL	PARAMETER	MAX	UNIT
R _{th(ch-c)}	Channel-to-case thermal resistance	1.1	°C/W
R _{th(ch-a)}	Channel-to-ambient thermal resistance	75	°C/W

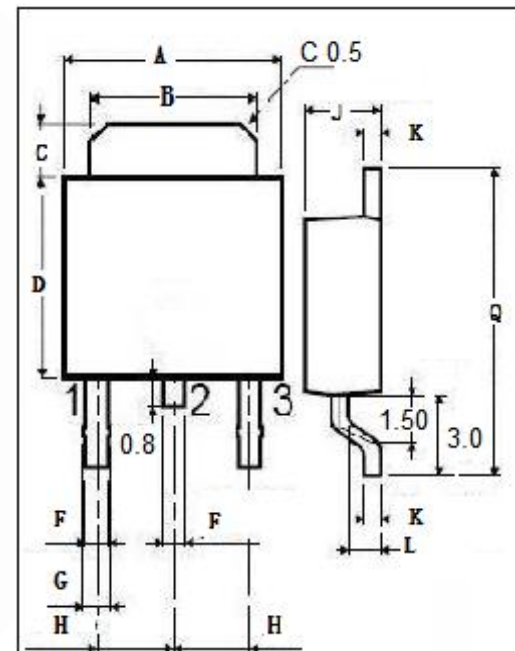
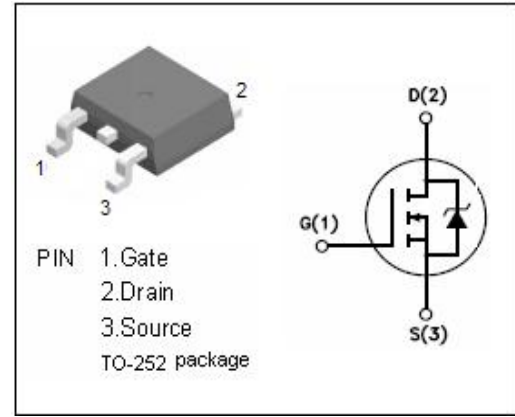

DIM	mm	
	MIN	MAX
A	6.40	6.60
B	5.20	5.40
C	1.15	1.35
D	5.70	6.10
F	0.65	
G	0.75	
H	2.10	2.50
J	2.10	2.40
K	0.40	0.60
L	0.90	1.10
Q	9.90	10.1

Isc N-Channel MOSFET Transistor
IPD30N03S2L
ELECTRICAL CHARACTERISTICS

 T_c=25°C unless otherwise specified

SYMBOL	PARAMETER	CONDITIONS	MIN	TYP	MAX	UNIT
BV _{DSS}	Drain-Source Breakdown Voltage	V _{GS} =0V; I _D = 1mA	30			V
V _{GS(th)}	Gate Threshold Voltage	V _{DS} =±20V; I _D =0.085mA	1.2		2.0	V
R _{DS(on)}	Drain-Source On-Resistance	V _{GS} = 10V; I _D =30A		5.6	6.7	mΩ
I _{GSS}	Gate-Source Leakage Current	V _{GS} = ±20V; V _{DS} = 0V			±0.1	μA
I _{DSS}	Drain-Source Leakage Current	V _{DS} =30V; V _{GS} = 0V; T _j =25°C T _j =125°C			1 100	μA
V _{SDF}	Diode forward voltage	I _{SD} =50A, V _{GS} = 0 V			1.3	V