

DESCRIPTION

The EV20046DQ-00A evaluation board demonstrates the performance of MP20046, a low noise, low dropout and high PSRR linear regulator. It operates from a 2.7V to 5.5V input voltage and the output voltage is preset internally which ranges from 1.5V to 3.3V.

The EV20046DQ-00A can supply up to 2A of load current, and features current limiting, over temperature protection and power-good status.

An internal PMOS pass element is used to allow a low 75µA ground current at full load, and drops down to 1µA when the device is disabled, making the MP20046 suitable for battery-power devices.

FEATURES

- Up to 2A Output Current
- Low 210mV Dropout at 2A
- Fast Transient Response
- 70dB PSRR at 100Hz
- 17µV_{RMS} Low Noise Output
- Open Drain Power-Good Status Output
- Current Limit and Thermal Protection

APPLICATIONS

- Telecom
- Servers
- DSP, FPGA Supplies

MPS® and "The Future of Analog IC Technology" are Registered Trademarks of Monolithic Power Systems, Inc.

ELECTRICAL SPECIFICATIONS

Parameter	Symbol	Value	Units
Input Voltage	V _{IN}	4.3 – 5.5	V
Output Voltage	V _{OUT}	3.3	V
Load Current	I _{OUT}	2	A

EV20046DQ-00A EVALUATION BOARD



(L x W x H) 2.5" x 2.5" x 0.4"
(6.35cm x 6.35cm x 1.1cm)

Board Number	MPS IC Number
EV20046DQ-00A	MP20046DQ

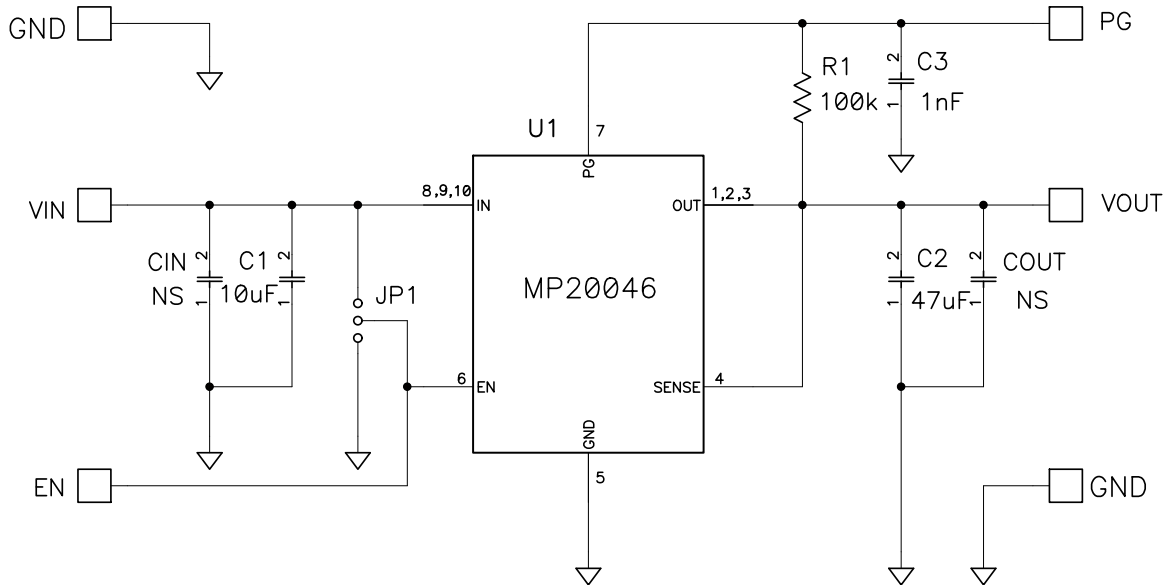
EVALUATION BOARD SCHEMATIC

EV20046DQ-00A BILL OF MATERIALS

Qty	Ref	Value	Description	Package	Manufacturer	Part Number
1	C1	10µF	Ceramic Capacitor X5R, 16V	0805	KYOCERA	CM21X5R106K16AT
1	C2	47µF	Ceramic Capacitor X5R, 10V	1210	Murata	GRM32ER61A476KE20L
1	CIN	NS				
1	COUT	NS				
1	C3	1nF	Ceramic Capacitor X7R, 50V	0805	TDK	C2012X7R1H102K
1	R1	100k	Film Res, 5%	0603	Any	
1	U1		LDO Regulator	QFN10(3x3)	MPS	MP20046DQ

PRINTED CIRCUIT BOARD LAYOUT

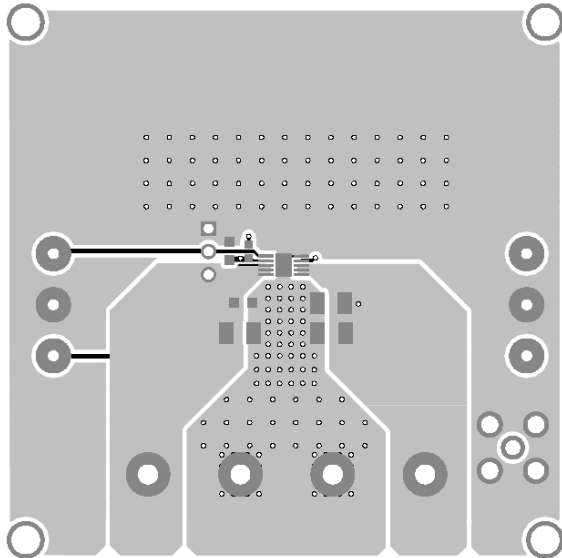

Figure 1—Top Layer

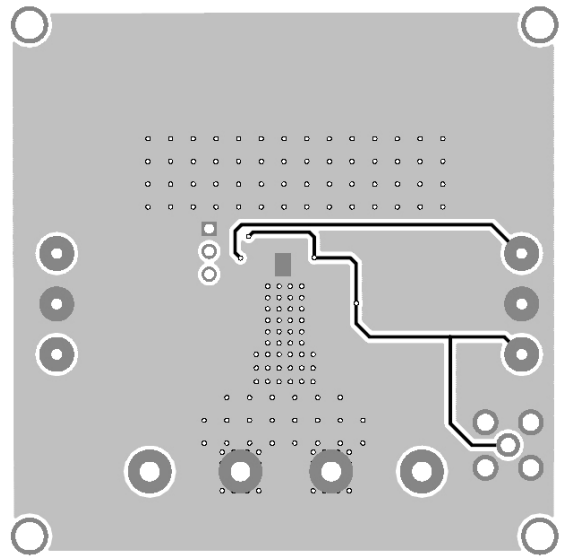

Figure 2—Bottom Layer

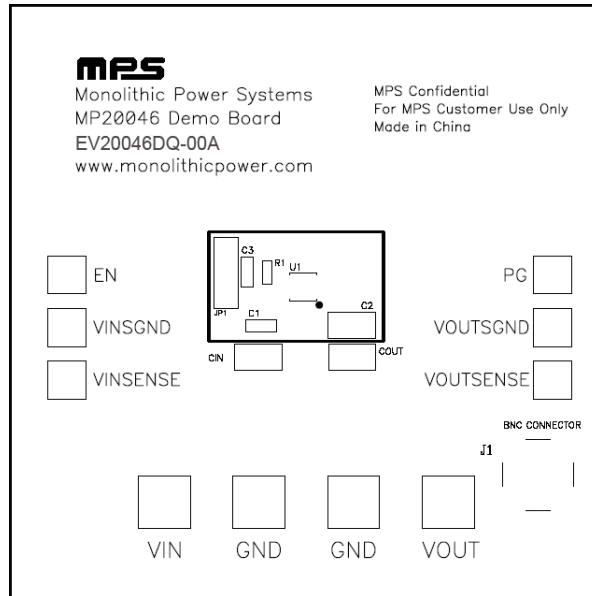

Figure 3—Top Silk Layer

QUICK START GUIDE

The output voltage of this board is set to 3.3V by operating from +4.3V to +5.5V input. The board layout accommodates most commonly used resistors and capacitors.

1. The /EN pin is connected to GND for automatic startup. You can connect /EN to VIN to disable the MP20046. Do not float the /EN pin.
2. Attach the positive and negative ends of the load to the VOUT and GND pins, respectively.
3. Attach the input voltage ($4.3V \leq V_{IN} \leq 5.5V$) and input ground to the VIN and GND pins, respectively.

To evaluate the other versions of MP20046DQ with different output voltages, carefully remove the IC (U1) and replace it with the corresponding chip. Please refer to the datasheet for the detailed information of different output voltage option of MP20046DQ.

NOTICE: The information in this document is subject to change without notice. Users should warrant and guarantee that third party Intellectual Property rights are not infringed upon when integrating MPS products into any application. MPS will not assume any legal responsibility for any said applications.