

**48V**  
Input

**12V**  
Output

**55A**  
Current

**2250V dc**  
Isolation

**Half-brick**  
DC-DC Converter

## PowerQor®

The PQ50120HZx50 PowerQor Zeta half-brick converter is a next-generation, board-mountable, isolated, fixed switching frequency DC/DC converter. The Zeta series offers industry leading power density for standard isolated DC/DC converters with a tightly regulated output. This 12V module provides 2,250Vdc isolation and more available power and higher efficiency than most competitive bus converters. RoHS Compliant (see last page).



PQ50120HZB55

### Operational Features

- High efficiency, 94% at full rated load current
- Delivers up to 55A of output current (660W)
- Input voltage range: 44-52V
- Fixed frequency switching provides predictable EMI performance
- No minimum load requirement means no preload resistors required
- Wide output voltage trim range (-50%, +10%), see trim section

### Mechanical Features

- Industry standard half-brick pin-out configuration
- Industry standard size: 2.390" x 2.490" x 0.512" (60.6 x 63.1 x 13.0mm)
- Height only 0.50" (12.7mm)
- Weight: 4.3oz (123g)

### Safety Features

- 2250V, 30MΩ input-to-output isolation
- UL 60950-1:2003 Basic Insulation
- CAN/CSA-C22.2 No. 60950-1:2003
- EN60950-1:2001
- RoHS compliant (see last page)

### Protection Features

- Input under-voltage lockout disables converter at low input voltage conditions
- Output current limit and short circuit protection protects converter and load from permanent damage and consequent hazardous conditions
- Active back bias limit provides smooth startup with external load induced pre-bias
- Latching output over-voltage protection protects load from damaging voltages
- Thermal shutdown protects converter from abnormal environmental conditions

### Control Features

- On/Off control referenced to input side (positive and negative logic options are available)

### Contents

	Page No.
MECHANICAL DIAGRAM (base-plated) . . . . .	2
Electrical Characteristics . . . . .	3-4
Standards and Qualifications . . . . .	5
Figures . . . . .	6-8
Application Section . . . . .	9-13
Ordering Information . . . . .	14

### MECHANICAL DIAGRAM (base-plated)

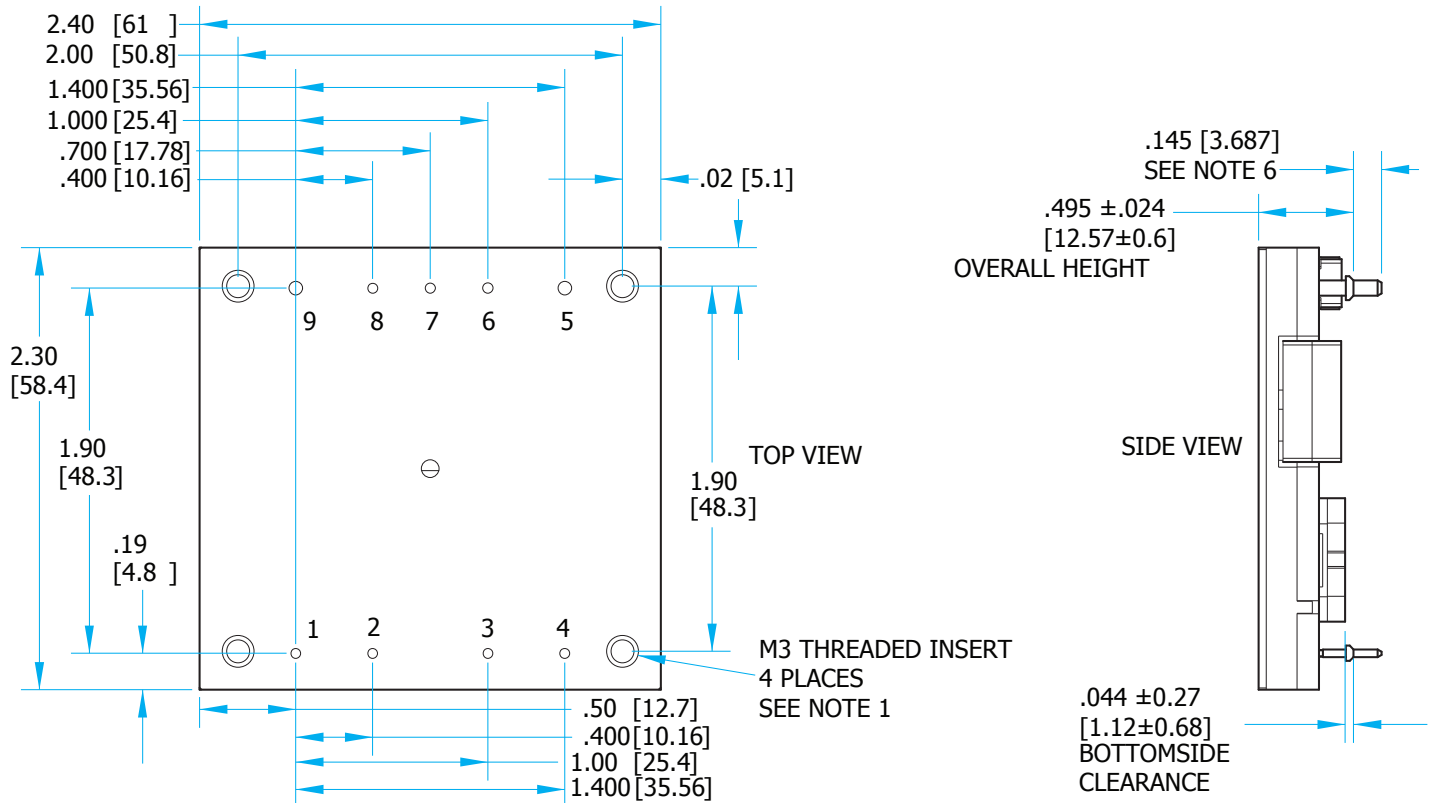

#### NOTES

- M3 screws used to bolt unit's baseplate to other surfaces (such as heatsink) must not exceed 0.100" (2.54 mm) depth below the surface of the baseplate.
- Applied torque per screw should not exceed 6in-lb. (0.7 Nm)
- Baseplate flatness tolerance is 0.004" (.10mm) TIR for surface
- Pins 1-4, 6-8 are 0.040" (1.02mm) diameter, with 0.080" (2.03mm) diameter standoff shoulders.
- Pins 5 and 9 are 0.080" (2.03 mm) diameter with 0.125" (3.18mm) diameter standoff shoulders.
- Other pin extension lengths available. Recommended pin length is 0.03" (0.76mm) greater than the PCB thickness.
- All Pins: Material: Copper Alloy  
Finish (RoHS 6/6): Matte Tin over Nickel plate
- Undimensioned components are shown for visual reference only.
- Weight: 4.3oz (123g)
- All dimensions in inches (mm) Tolerances: x.xx +/-0.02 in. (x.x +/-0.5mm) x.xxx +/-0.010 in. (x.xx +/-0.25mm)
- Workmanship: Meets or exceeds IPC-A-610C Class II
- The flanged pins are designed to permit surface mount soldering (allowing to avoid the wave soldering process) through the use of the flanged pin-in-paste technique.

#### PIN DESIGNATIONS

Pin	Name	Function
1	Vin(+)	Positive input voltage
2	ON/OFF	TTL input to turn converter on and off, referenced to Vin(-), with internal pull up.
3	Reserved	Not connected
4	Vin(-)	Negative input voltage
5	Vout(-)	Negative output voltage
6	SENSE(-)	Negative remote sense; see note 1
7	TRIM	Output voltage trim; see note 2
8	SENSE(+)	Positive remote sense; see note 3
9	Vout(+)	Positive output voltage

#### Notes:

- SENSE(-) should be connected to Vout(-) either remotely or at the converter.
- Leave TRIM pin open for nominal output voltage.
- SENSE(+) should be connected to Vout(+) either remotely or at the converter.

## PQ50120HZB55 Electrical Characteristics

Ta = 25 °C, airflow rate = 300 LFM, Vin = 48V dc unless otherwise noted; full operating temperature range is -40 °C to +100 °C baseplate temperature with appropriate power derating. Specifications subject to change without notice.

Parameter	Min.	Typ.	Max.	Units	Notes & Conditions
<b>ABSOLUTE MAXIMUM RATINGS</b>					
Input Voltage					
Non-Operating			100	V	Continuous
Operating			60	V	Continuous
Isolation Voltage					
Input to Output			2250	V	
Operating Temperature	-40		100	°C	
Storage Temperature	-55		125	°C	
Voltage at ON/OFF input pin	-2		18	V	
<b>INPUT CHARACTERISTICS</b>					
Operating Input Voltage Range	44	48	52	V	
Input Under-Voltage Lockout					
Turn-On Voltage Threshold	31.5	33.0	34.5	V	
Turn-Off Voltage Threshold	29.0	30.5	32.0	V	
Lockout Voltage Hysteresis	1.5	2.5	3.5	V	
Maximum Input Current			21.0	A	In Current Limit, Vin min, trimmed up 10%
No-Load Input Current		125	200	mA	
Disabled Input Current		20	40	mA	
Input Reflected Ripple Current		5	20	mA	RMS thru 4.7µH inductor
Input Terminal Ripple Current		220		mA	RMS
Recommended Input Fuse			30	A	Fast acting external fuse recommended
Recommended External Input Capacitance		220		µF	Typical ESR 0.1-0.2Ω; Figure 13
Input Filter Component Values (L\C)		0.75\11		µH\µF	Internal values
<b>OUTPUT CHARACTERISTICS</b>					
Output Voltage Set Point	11.72	12.00	12.28	V	
Output Voltage Regulation					
Over Line		±1.0\120		%\mV	See note 1
Over Load		±1.0\120		%\mV	See note 1
Over Temperature		±90	±240	mV	
Total Output Voltage Range	11.60		12.40	V	Over sample, line, load, temperature & life
Output Voltage Ripple and Noise					20MHz bandwidth; see Note 2
Peak-to-Peak		90	150	mV	Full load
RMS		20	30	mV	Full load
Operating Output Current Range	0		55	A	Subject to thermal derating
Output DC Current-Limit Inception	60.0	65.0	70.0	A	Output Voltage 10% Low
Output DC Current-Limit Shutdown Voltage		5.0		V	See note 3
Back-Drive Current Limit while Enabled	15	20	25	A	Negative current drawn from output
Back-Drive Current Limit while Disabled	0	3	4	mA	Negative current drawn from output
Maximum Output Capacitance Electrolytic			12	mF	Nominal Vout at full load (resistive load)
<b>EFFICIENCY</b>					
100% Load		94		%	Figures 1 - 2
50% Load		95		%	Figures 1 - 2

## PQ50120HZB55 Electrical Characteristics (continued)

Ta = 25 °C, airflow rate = 300 LFM, Vin = 48V dc unless otherwise noted; full operating temperature range is -40 °C to +100 °C baseplate temperature with appropriate power derating. Specifications subject to change without notice.

Parameter	Min.	Typ.	Max.	Units	Notes & Conditions
<b>DYNAMIC CHARACTERISTICS</b>					
Output Voltage during Load Current Transient					
Step Change in Output Current (0.1A/μs)		350		mV	50% to 75% to 50% Iout max, 470 μF load cap
Step Change in Output Current (5A/μs)		500		mV	
Settling time		1		ms	To within 1% Vout nom
Turn-On Transient					
Turn-On Time		29		ms	Full load, Vout=90% nom; Figures 5 & 6
Output Voltage Overshoot			2	%	
<b>ISOLATION CHARACTERISTICS</b>					
Isolation Voltage (dielectric strength)		2250		V	See Absolute Maximum Ratings
Isolation Resistance		30		MΩ	
Isolation Capacitance (input to output)		1000		pF	See Note 4
<b>TEMPERATURE LIMITS FOR POWER DERATING CURVES</b>					
Semiconductor Junction Temperature			125	°C	Package rated to 150°C
Board Temperature			125	°C	UL rated max operating temp 130°C
Transformer Temperature			125	°C	
<b>FEATURE CHARACTERISTICS</b>					
Switching Frequency Regulation Stage	230	240	250	kHz	
Switching Frequency Isolation Stage	115	120	125	kHz	
ON/OFF Control (Option P)					
Off-State Voltage	-2.0		1.0	V	
On-State Voltage	4.0		18.0	V	
ON/OFF Control (Option N)					
Off-State Voltage	4.0		18	V	
On-State Voltage	-2.0		1.0	V	
ON/OFF Control (Either Option)					Application notes; Figure A
ON/OFF Control Hysteresis		1.5		V	
Pull-Up Voltage	4.75	5.00	5.25	V	
Pull-Up Resistance		10		kΩ	
Output Voltage Trim Range	-50		10	%	Measured across Pins 8 & 4; Figure B
Output Over-Voltage Protection	13.6	14.2	14.8	V	Over Full Temperature Range
Over-Temperature Shutdown		125		°C	Average PCB Temperature
Over-Temperature Shutdown Restart Hysteresis		10		°C	
<b>RELIABILITY CHARACTERISTICS</b>					
Calculated MTBF (Telcordia)		2.1		10 <sup>6</sup> Hrs.	TR-NWT-000332; 80% load, 300LFM, 40°C Ta
Calculated MTBF (MIL-217)		1.9		10 <sup>6</sup> Hrs.	MIL-HDBK-217F; 80% load, 300LFM, 40°C Ta
Field Demonstrated MTBF				10 <sup>6</sup> Hrs.	See our website for details

Note 1: Line and load regulation is limited by duty cycle quantization and does not indicate a shift in the internal voltage reference.

Note 2: For applications requiring reduced output voltage ripple and noise, consult SynQor applications support (e-mail: support@synqor.com)

Note 3: If the output voltage falls below the Output DC Current Limit Shutdown Voltage for more than 50ms, then the unit will enter into hiccup mode, with a 500ms off-time.

Note 4: Higher values of isolation capacitance can be added external to the module.





# Technical Specification

**Input: 44-52V**  
**Output: 12V**  
**Current: 55A**  
**Part No.: PQ50120HZB55**

## Standards and Qualifications

Parameter	Notes & Conditions
<b>STANDARDS COMPLIANCE</b>	
UL 60950-1:2003	Basic Insulation
CAN/CSA-C22.2 No. 60950-1:2003	
EN60950-1:2001	
IEC 61000-4-2	ESD test, 8 kV - NP, 15 kV air - NP (Normal Performance)

Note: An external input fuse must always be used to meet these safety requirements. Contact SynQor for official safety certificates on new releases or download from the SynQor website.

Parameter	# Units	Test Conditions
<b>QUALIFICATION TESTING</b>		
Life Test	32	95% rated Vin and load, units at derating point, 1000 hours
Vibration	5	10-55 Hz sweep, 0.060" total excursion, 1 min./sweep, 120 sweeps for 3 axis
Mechanical Shock	5	100g minimum, 2 drops in x and y axis, 1 drop in z axis
Temperature Cycling	10	-40 °C to 100 °C, unit temp. ramp 15 °C/min., 500 cycles
Power/Thermal Cycling	5	Toperating = min to max, Vin = min to max, full load, 100 cycles
Design Marginality	5	Tmin-10 °C to Tmax+10 °C, 5 °C steps, Vin = min to max, 0-105% load
Humidity	5	85 °C, 85% RH, 1000 hours, continuous Vin applied except 5 min/day
Solderability	15 pins	MIL-STD-883, method 2003

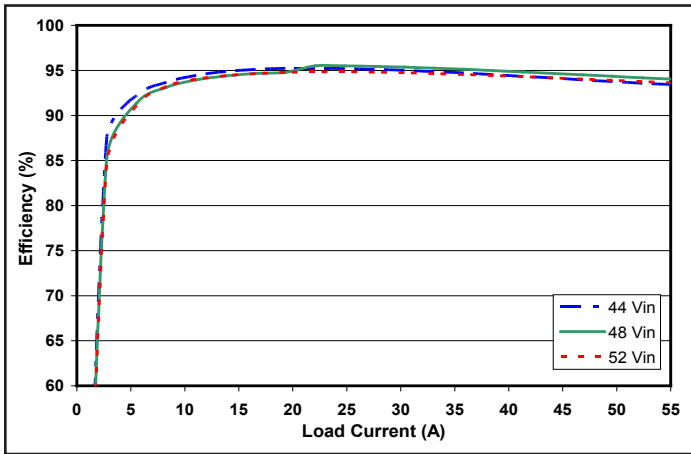

Figure 1: Efficiency at nominal output voltage vs. load current for minimum, nominal, and maximum input voltage at 25°C.

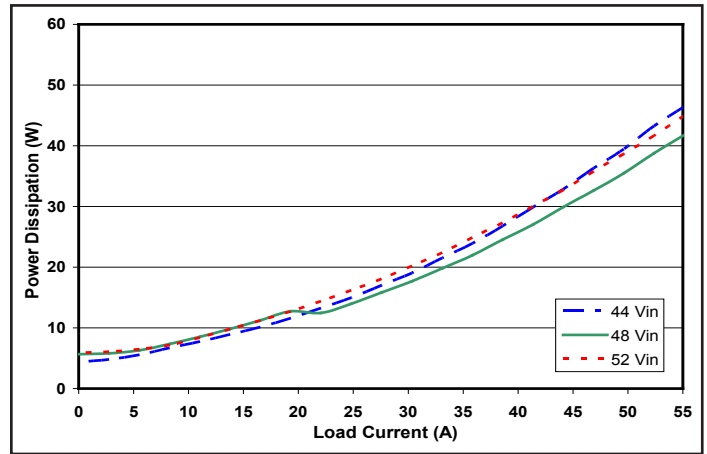

Figure 2: Power dissipation at nominal output voltage vs. load current for minimum, nominal, and maximum input voltage at 25°C.

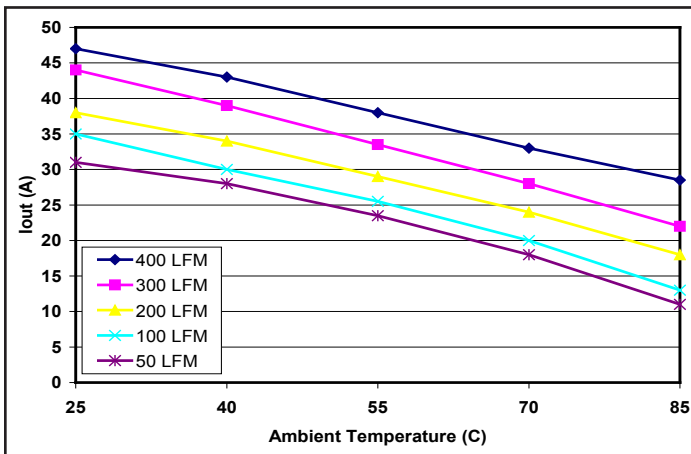

Figure 3: Maximum output power-derating curve vs. ambient air temperature for airflow rates of 100LFM through 400LFM with air flowing from pin 4 to pin 1 (nominal input voltage).

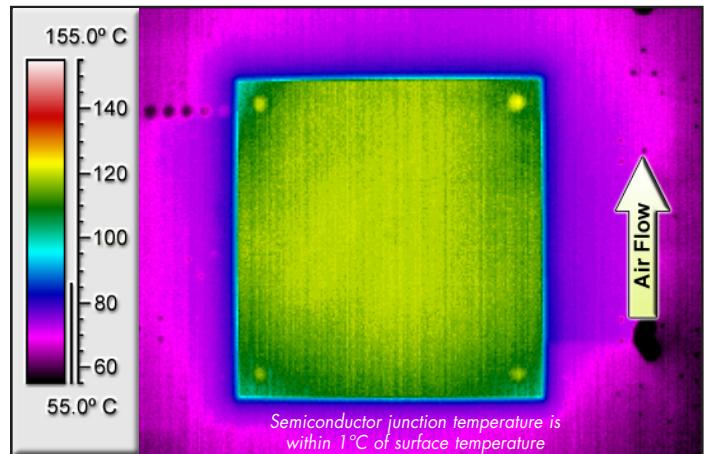

Figure 4: Thermal plot of converter at 36A load current (432W) with 55°C air flowing at the rate of 200LFM. Air is flowing across the converter from pin 4 to pin 1 (nominal input voltage).

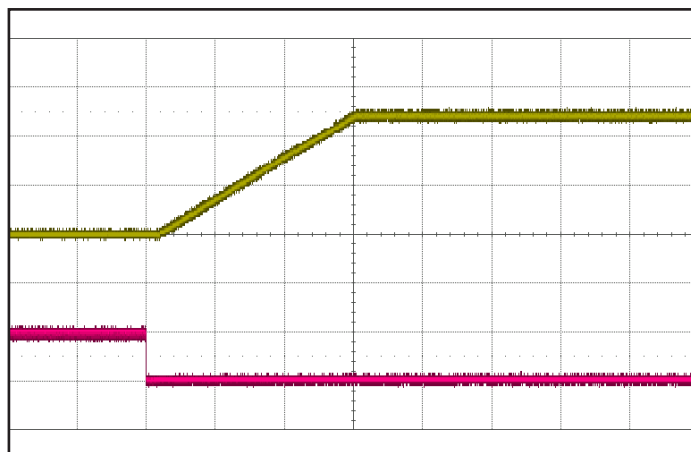

Figure 5: Turn-on transient at full load (resistive load) (10 ms/div).  
 Ch 1: Vout (5 V/div)  
 Ch 2: ON/OFF input (5 V/div)

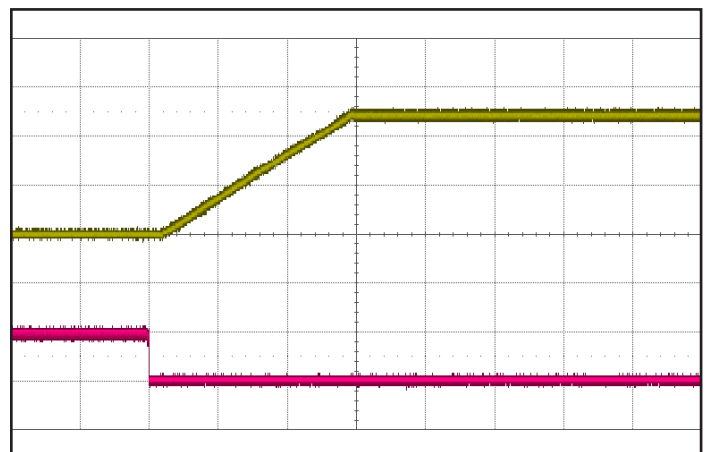

Figure 6: Turn-on transient at zero load (10 ms/div).  
 Ch 1: Vout (5 V/div)  
 Ch 2: ON/OFF input (5 V/div)

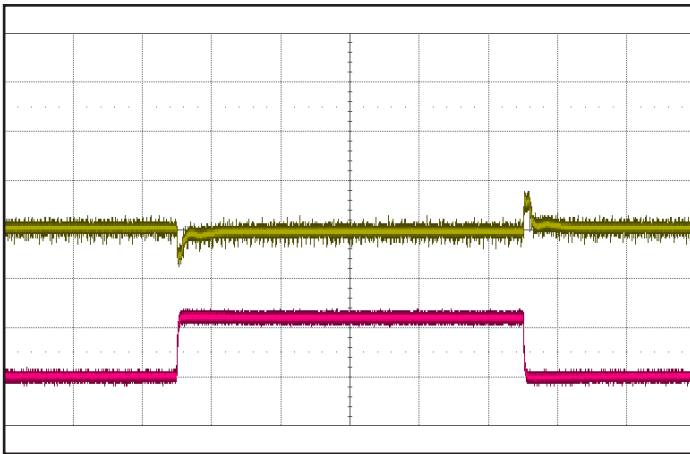

Figure 7: Output voltage response to step-change in load current (50%-75%-50% of  $I_{out(max)}$ ;  $dI/dt = 0.1 A/\mu s$ ; 1 ms/div). Load cap: 1 $\mu F$  ceramic and 470  $\mu F$  electrolytic capacitors. Top trace:  $V_{out}$  (500 mV/div). Bottom trace:  $I_{out}$  (10 A/div).

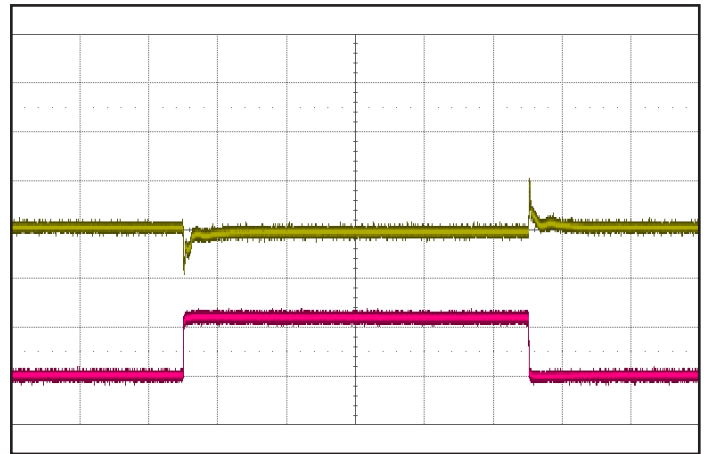

Figure 8: Output voltage response to step-change in load current (50%-75%-50% of  $I_{out(max)}$ ;  $dI/dt = 5 A/\mu s$ ; 1 ms/div). Load cap: 470  $\mu F$  electrolytic capacitor. Top trace:  $V_{out}$  (500 mV/div). Bottom trace:  $I_{out}$  (10 A/div).

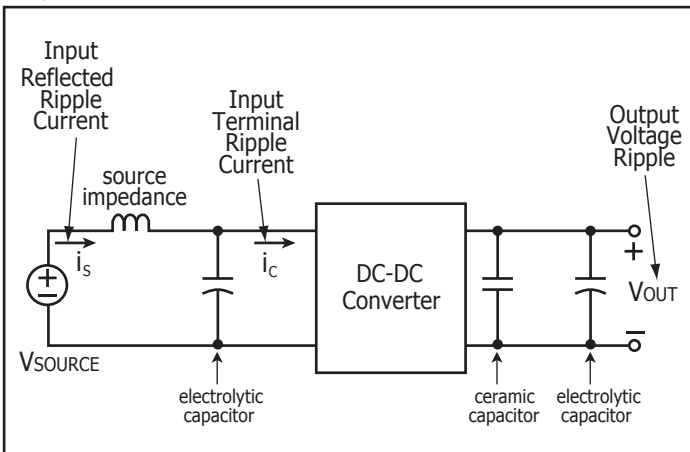

Figure 9: Test set-up diagram showing measurement points for Input Terminal Ripple Current (Figure 10), Input Reflected Ripple Current (Figure 11) and Output Voltage Ripple (Figure 12).

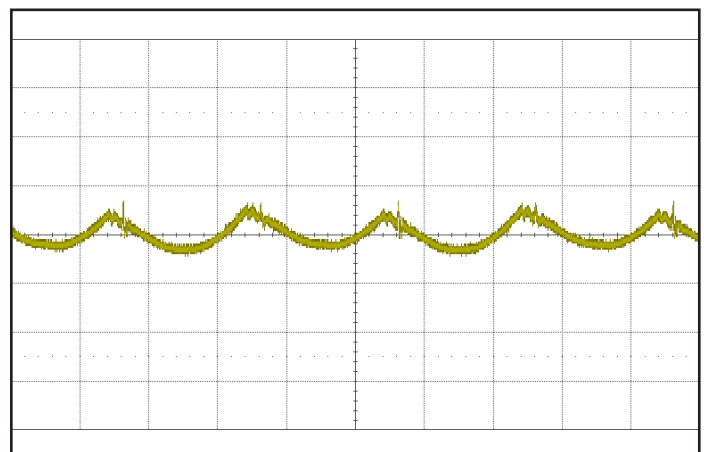

Figure 10: Input Terminal Ripple Current,  $i_c$ , at full rated output current and nominal input voltage with 4.7  $\mu H$  source impedance and 220  $\mu F$  electrolytic capacitor (1 A/div; 2  $\mu s$ /div). See Figure 9.

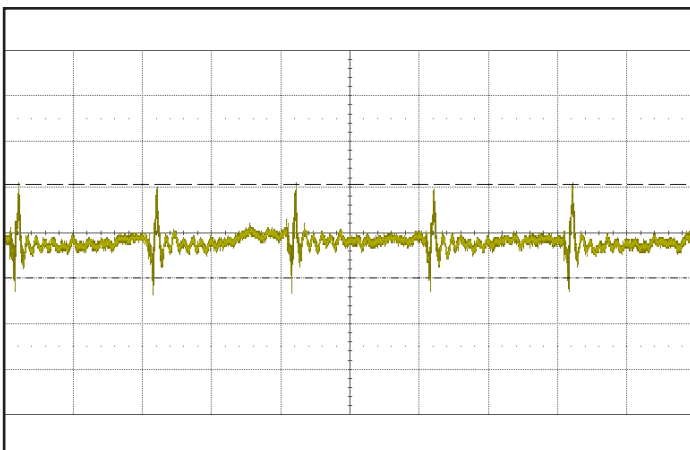

Figure 11: Input reflected ripple current,  $i_s$ , through a 4.7  $\mu H$  source inductor, using a 220  $\mu F$  input capacitor, at nominal input voltage and rated load current (10 mA/div; 2  $\mu s$ /div). See Figure 9.

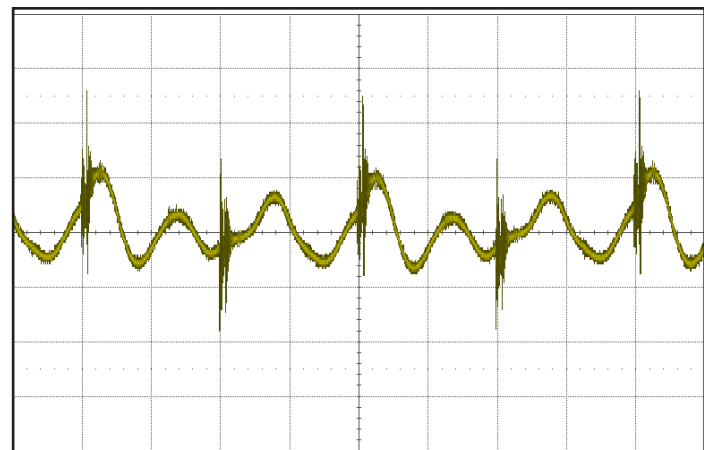

Figure 12: Output voltage ripple at nominal input voltage and rated load current (50 mV/div; 2  $\mu s$ /div). Load capacitance: 1  $\mu F$  ceramic capacitor and 15  $\mu F$  tantalum capacitor. Bandwidth: 20 MHz. See Figure 9.

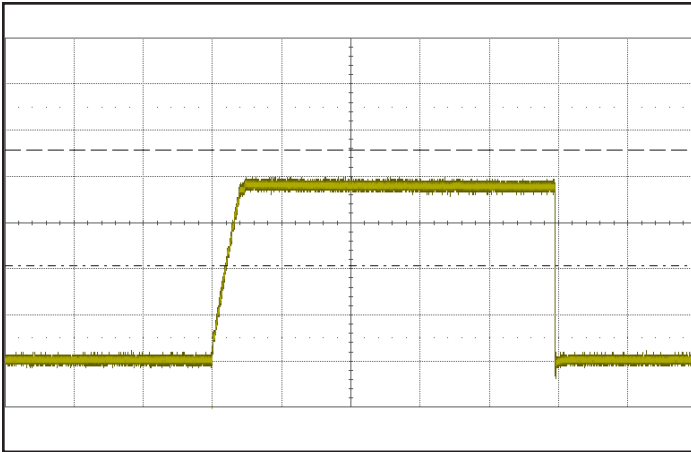

Figure 13: Load current (10 A/div; 10 ms/div) as a function of time when the converter attempts to turn on into a 1 mW short circuit.

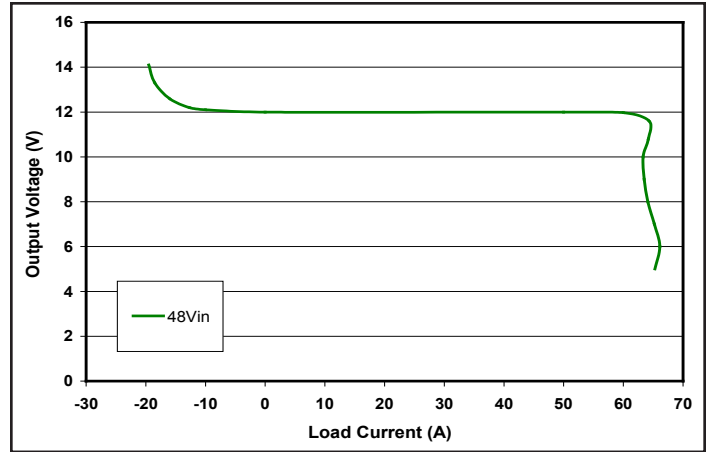

Figure 14: Output voltage vs. load current showing typical current limit curves and OVP shutdown point.



### BASIC OPERATION AND FEATURES

The PowerQor Zeta series converter uses a two-stage power conversion topology. The first stage keeps the output voltage constant over variations in line, load, and temperature. The second stage uses a transformer to provide the functions of input/output isolation and voltage step-down to achieve the low output voltage required.

Both the first stage and the second stage switch at a fixed frequency for predictable EMI performance. Rectification of the transformer's output is accomplished with synchronous rectifiers. These devices, which are MOSFETs with a very low on-state resistance, dissipate significantly less energy than Schottky diodes, enabling the PowerQor converter to achieve high efficiency.

The PowerQor series of half-brick, quarter-brick and eighth-brick converters uses the industry standard footprint and pin-out configuration.

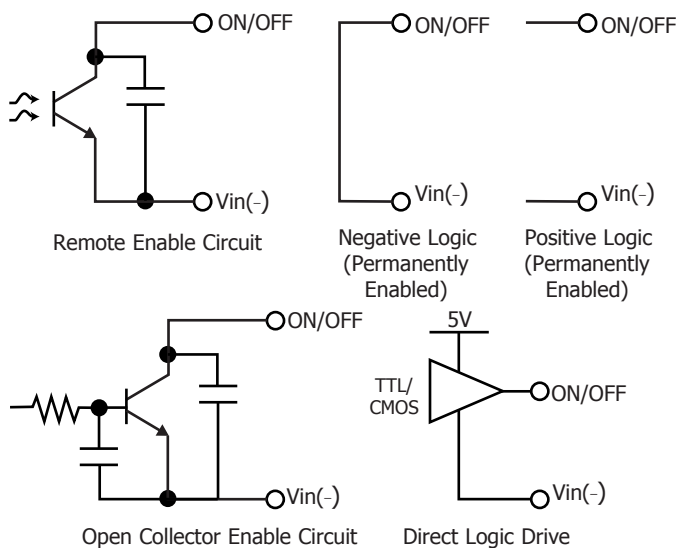

Figure A: Various circuits for driving the ON/OFF pin.

### CONTROL FEATURES

**REMOTE ON/OFF (Pin 2):** The ON/OFF input, Pin 2, permits the user to control when the converter is *on* or *off*. This input is referenced to the return terminal of the input bus, Vin(-). The converter is available with either positive or negative logic used for the ON/OFF input.

In the positive logic version, the ON/OFF input is active high (meaning that a high voltage turns the converter *on*). In the negative logic version, the ON/OFF signal is active low (meaning that a low voltage turns the converter *on*). Figure A details five possible circuits for driving the ON/OFF pin.

**REMOTE SENSE(±) (Pins 7 and 5):** The SENSE(±) inputs correct for voltage drops along the conductors that connect the converter's output pins to the load.

Pin 7 should be connected to Vout(+) and Pin 5 should be connected to Vout(-) at the point on the board where regulation is desired. If these connections are not made, the converter will deliver an output voltage that is slightly higher than its specified value.

**Note:** The output over-voltage protection circuit senses the voltage across the sense leads (pins 7 and 5) to determine when it should trigger, not the voltage across the converter's output pins (pins 8 and 4).

**OUTPUT VOLTAGE TRIM (Pin 6):** The TRIM input permits the user to adjust the output voltage across the sense leads up or down according to the trim range specifications. SynQor uses industry standard trim equations.

To decrease the output voltage, the user should connect a resistor between Pin 6 (TRIM) and Pin 5 (SENSE(-) input). For a desired decrease of the nominal output voltage, the value of the resistor should be:

$$R_{\text{trim-down}} = \left( \frac{100\%}{\Delta} \right) - 2 \text{ k}\Omega$$

where

$$\Delta\% = \left| \frac{V_{\text{nominal}} - V_{\text{desired}}}{V_{\text{nominal}}} \right| \times 100\%$$

To increase the output voltage, the user should connect a resistor between Pin 6 (TRIM) and Pin 7 (SENSE(+)) input. For a desired increase of the nominal output voltage, the value of the resistor should be

$$R_{\text{trim-up}} = \frac{\left( \frac{V_{\text{nominal}}}{1.225} - 2 \right) \times V_{\text{DES}} + V_{\text{NOM}}}{V_{\text{DES}} - V_{\text{NOM}}} \text{ k}\Omega$$

Figure B graphs the relationship between the trim resistor value, Rtrim-up and Rtrim-down, showing the total range the output voltage can be trimmed up or down.

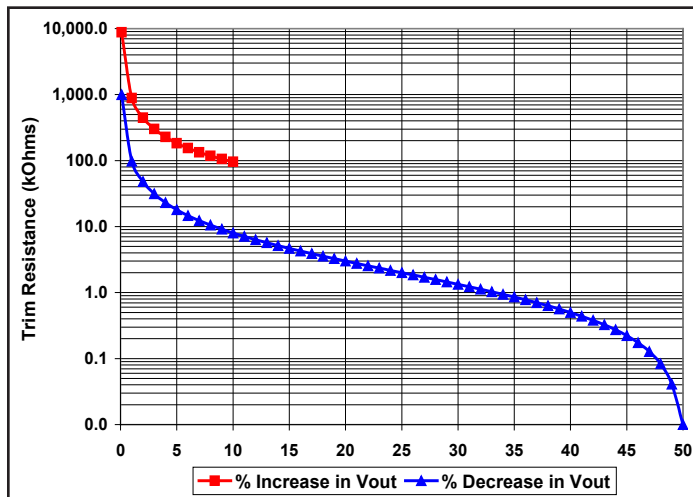

**Figure B:** Trim Graph for 12Vout module

**Note:** The TRIM feature does not affect the voltage at which the output over-voltage protection circuit is triggered. Trimming the output voltage too high may cause the over-voltage protection circuit to engage, particularly during transients.

It is not necessary for the user to add capacitance at the Trim pin. The node is internally filtered to eliminate noise.

**Total DC Variation of Vout:** For the converter to meet its full specifications, the maximum variation of the DC value of Vout, due to both trimming and remote load voltage drops, should not be greater than that specified for the output voltage trim range.

## PROTECTION FEATURES

**Input Under-Voltage Lockout:** The converter is designed to turn off when the input voltage is too low, helping to avoid an input system instability problem, which is described in more detail in the application note titled "Input System Instability" on the SynQor website. The lockout circuitry is a comparator with DC hysteresis. When the input voltage is rising, it must exceed the typical "Turn-On Voltage Threshold" value\* before the converter will turn on. Once the converter is on, the input voltage must fall below the typical Turn-Off Voltage Threshold value before the converter will turn off.

**Output Current Limit:** If the output current exceeds the "Output DC Current Limit Inception" point\*, then a fast linear current limit controller will reduce the output voltage to maintain a constant output current. If as a result, the output voltage falls below the "Output DC Current Limit Shutdown Voltage"\* for more than 50ms, then the unit will enter into hiccup mode, with a 500ms off-time. The unit will then automatically attempt to restart.

**Back-Drive Current Limit:** If there is negative output current of a magnitude larger than the "Back-Drive Current Limit while Enabled" specification\*, then a fast back-drive limit controller will increase the output voltage to maintain a constant output current. If this results in the output voltage exceeding the "Output Over-Voltage Protection" threshold\*, then the unit will shut down. The full I-V output characteristics can be seen in the figures.

**Output Over-Voltage Limit:** If the voltage directly across the output pins exceeds the "Output Over-Voltage Protection" threshold\*, the converter will immediately stop switching. This shutdown is latching; unlike other shutdown types, the converter will not restart unless the input power is cycled or the ON/OFF input is toggled.

**Over-Temperature Shutdown:** A temperature sensor on the converter senses the average temperature of the module. The thermal shutdown circuit is designed to turn the converter off when the temperature at the sensed location reaches the "Over-Temperature Shutdown" value\*. It will allow the converter to turn on again when the temperature of the sensed location falls by the amount of the "Over-Temperature Shutdown Restart Hysteresis" value\*.

\* See Electrical Characteristics page.

### APPLICATION CONSIDERATIONS

**Limited Output Voltage Resolution:** The internal voltage control feedback loop has limited resolution. Therefore, the output voltage will exhibit discrete steps as the loop responds to changes in line, load, trim, or remote sense. For instance, on close examination, the startup ramp has a “stair-step” shape. Likewise, a load transient response will be composed of multiple discrete steps. The size of each step is well determined, and is shown in Figure C. A close-up picture of a single step is shown in Figure D. Stepping will not occur under steady state conditions.

**Current share and active trim not recommended:** It is important to note that external feedback control using the sense or trim pins will cause sustained stepping. External current share or active trim circuits contain a separate reference voltage.

After this external feedback has taken control, the actual output voltage can still differ from the external reference voltage by as much as the step size. If the external feedback loop integrates this error voltage, it will cause a limit cycle oscillation. For this reason, external feedback using the sense and trim pins is not recommended.

**Input System Instability:** This condition can occur because any DC/DC converter appears incrementally as a negative resistance load. A detailed application note titled “Input System Instability” is available on the SynQor website which provides an understanding of why this instability arises, and shows the preferred solution for correcting it.

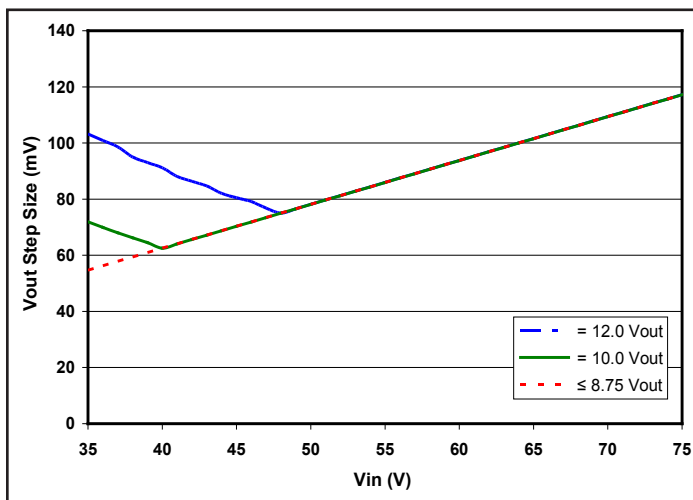

Figure C: Output voltage resolution.

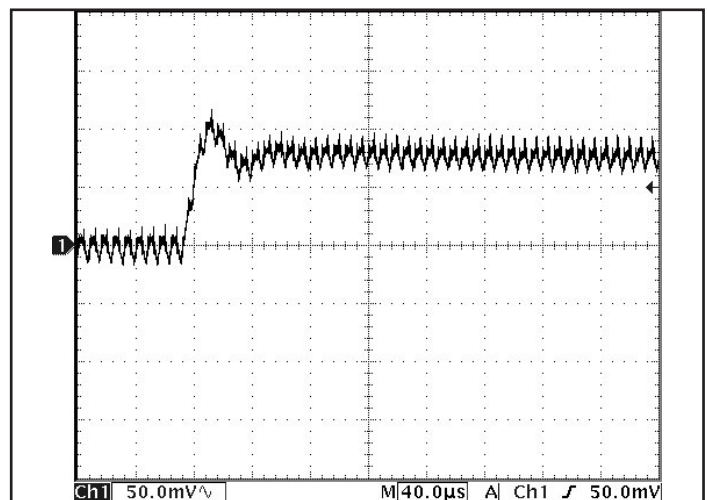

Figure D: Smallest possible Vout step at 48Vin and 12Vout.

\* See Electrical Characteristics page.

**Application Circuits:** Figure E below provides a typical circuit diagram which details the input filtering and voltage trimming.

**Input Filtering and External Input Capacitance:** Figure F below shows the internal input filter components. This filter dramatically reduces input terminal ripple current, which otherwise could exceed the rating of an external electrolytic input capacitor. The recommended external input capacitance is specified in the Input Characteristics section on the Electrical Specifications page. More detailed information is available in the application note titled "EMI Characteristics" on the SynQor website.

**Output Filtering and External Output Capacitance:** Figure F below shows the internal output filter components. This filter dramatically reduces output voltage ripple. However, some minimum external output capacitance is required, as specified in the Output Characteristics section on the Electrical Specifications page. No damage will occur without this capacitor connected, but peak output voltage ripple will be much higher.

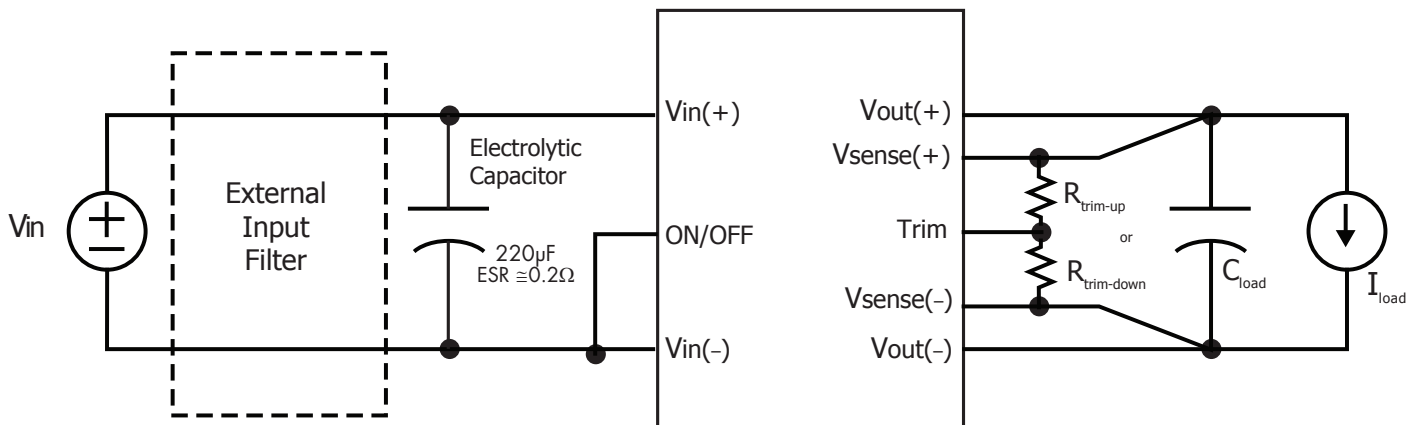

*Figure E: Typical application circuit (negative logic unit, permanently enabled).*

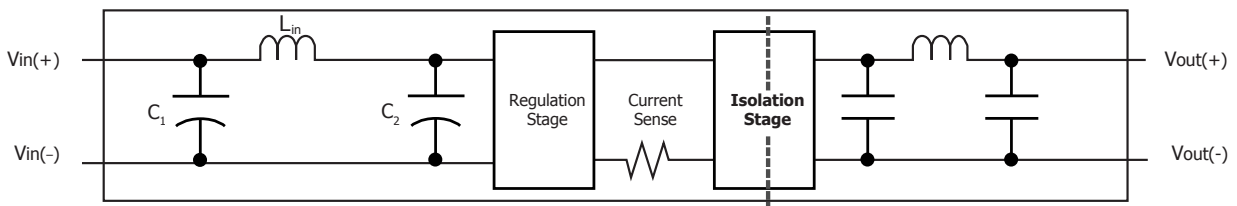

*Figure F: Internal Input and Output Filter Diagram (component values listed on specifications page).*





## Technical Specification

**Input: 44-52V**  
**Output: 12V**  
**Current: 55A**  
**Part No.: PQ50120HZB55**

**Thermal Considerations:** The maximum operating base-plate temperature,  $T_B$ , is 100 °C. As long as the user's thermal system keeps  $T_B \leq 100$  °C, the converter can deliver its full rated power.

A power derating curve can be calculated for any heatsink that is attached to the base-plate of the converter. It is only necessary to determine the thermal resistance,  $R_{TH_{BA}}$ , of the chosen heatsink between the base-plate and the ambient air for a given airflow rate. This information is usually available from the heatsink vendor. The following formula can be used to determine the maximum power the converter can dissipate for a given thermal condition if its base-plate is to be no higher than 100 °C.

$$P_{diss}^{max} = \frac{100 \text{ }^\circ\text{C} - T_A}{R_{TH_{BA}}}$$

This value of power dissipation can then be used in conjunction with the data shown in Figure 2 to determine the maximum load current (and power) that the converter can deliver in the given thermal condition.



# Technical Specification

**Input:44-52V**  
**Output:12V**  
**Current:55A**  
**Part No.:PQ50120HZB55**

## PART NUMBERING SYSTEM

The part numbering system for SynQor’s dc-dc converters follows the format shown in the example below.

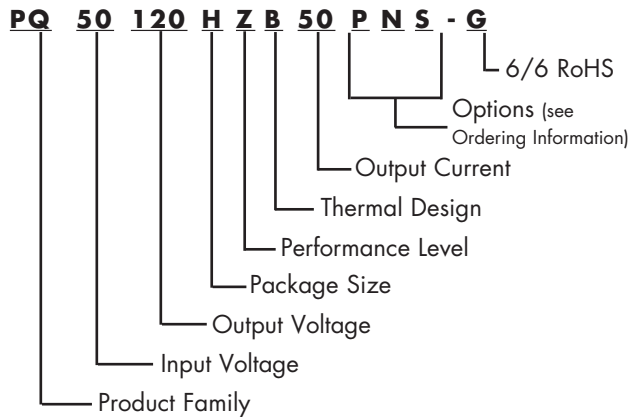

The first 12 characters comprise the base part number and the last 3 characters indicate available options. The “-G” suffix indicates 6/6 RoHS compliance.

## Application Notes

A variety of application notes and technical white papers can be downloaded in pdf format from our website.

**RoHS Compliance:** The EU led RoHS (Restriction of Hazardous Substances) Directive bans the use of Lead, Cadmium, Hexavalent Chromium, Mercury, Polybrominated Biphenyls (PBB), and Polybrominated Diphenyl Ether (PBDE) in Electrical and Electronic Equipment. This SynQor product is 6/6 RoHS compliant. For more information please refer to SynQor’s RoHS addendum available at our [RoHS Compliance / Lead Free Initiative web page](#) or e-mail us at [rohs@synqor.com](mailto:rohs@synqor.com).

## ORDERING INFORMATION

The tables below show the valid model numbers and ordering options for converters in this product family. When ordering SynQor converters, please ensure that you use the complete 15 character part number consisting of the 12 character base part number and the additional 3 characters for options. Add “-G” to the model number for 6/6 RoHS compliance.

Model Number	Input Voltage	Output Voltage	Max Output Current
PQ50120HZB55PNS-G	44-52V	12V	55A

Options Description			
Thermal Design	Enable Logic	Pin Style	Feature Set
B - Baseplate	P - Positive	N - 0.145"	S - Standard

Not all combinations make valid part numbers, please contact SynQor for availability. See the [Product Summary web page](#) for more options. Many operational functions of this converter are programmable. Contact the factory regarding customizing.

## PATENTS

SynQor holds the following U.S. patents, one or more of which apply to each product listed in this document. Additional patent applications may be pending or filed in the future.

5,999,417	6,222,742	6,545,890	6,577,109	6,594,159
6,731,520	6,894,468	6,896,526	6,927,987	7,050,309
7,072,190	7,085,146	7,119,524	7,269,034	7,272,021
7,272,023	7,558,083	7,564,702		

## Contact SynQor for further information:

**Phone:** 978-849-0600  
**Toll Free:** 888-567-9596  
**Fax:** 978-849-0602  
**E-mail:** [power@synqor.com](mailto:power@synqor.com)  
**Web:** [www.synqor.com](http://www.synqor.com)  
**Address:** 155 Swanson Road  
 Boxborough, MA 01719  
 USA

### Warranty

SynQor offers a three (3) year limited warranty. Complete warranty information is listed on our website or is available upon request from SynQor.

Information furnished by SynQor is believed to be accurate and reliable. However, no responsibility is assumed by SynQor for its use, nor for any infringements of patents or other rights of third parties which may result from its use. No license is granted by implication or otherwise under any patent or patent rights of SynQor.