

Product Description

The QPA2705 is an integrated 2-stage Power Amplifier Module designed for Metro Cell Base Station applications with 5 W RMS at the device output.

The module is 50 Ω input and output and requires minimal external components. The module is also compact and offers a much smaller footprint than traditional discrete component solutions.

The QPA2705 incorporates a Doherty final stage delivering high power added efficiency for the entire module at 5 W average power.

RoHS compliant.

Functional Block Diagram

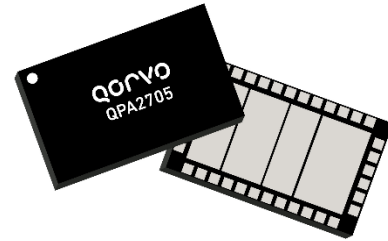
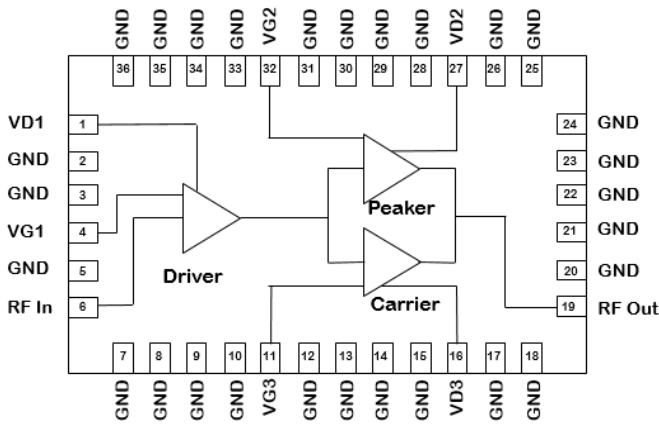

36 Pin 6x10 mm Plastic Package

Product Features

- Operating Frequency Range: 2500-2700 MHz
- Band 41, Band 7
- Operating Drain Voltage: +28 V
- 50 Ω Input / Output
- Integrated Doherty Final Stage
- Gain at 5 W avg.: 34.1 dB
- Power Added Efficiency at 5 W avg.: 41.6%
- 6x10 mm Plastic Surface Mount Package

Applications

- 5G Massive MIMO
- W-CDMA / LTE
- Macrocell Base Station Driver
- Microcell Base Station
- Small Cell Final Stage
- Active Antenna
- General Purpose Applications

Ordering Information

Part No.	ECCN	Description
QPA2705SB	5A991G	Sample Bag – 5 Pieces
QPA2705SR	5A991G	Short Reel – 100 Pieces
QPA2705TR13	5A991G	13" Reel – 2500 Pieces
QPA2705EVB01	EAR99	Tested 2.5 – 2.7 GHz EVB

Absolute Maximum Ratings²

Parameter	Range / Value	Units
Breakdown Voltage, BV_{DG}	120	V
Gate Voltage ($V_{G1,2,3}$)	-7 to +2	V
Drain Voltage ($V_{D1,2,3}$)	+40	V
RF Input Power	+22	dBm
VSWR Mismatch, P1dB Pulse (10 % duty cycle, 100 μ width), $T = 25^\circ\text{C}$	10:1	
Channel Temperature, T_{CH}	275	$^\circ\text{C}$
Storage Temperature	-65 to +150	$^\circ\text{C}$

Operation of this device outside the parameter ranges given above may cause permanent damage.

Recommended Operating Conditions

Parameter	Min	Typ	Max	Units
Operating Temperature	-40	+25		$^\circ\text{C}$
Gate Voltage (V_{G1})		-2.6		V
Gate Voltage (V_{G2})		-4.4		V
Gate Voltage (V_{G3})		-2.6		V
Drain Voltage ($V_{D1,2,3}$)		+28		V
Quiescent Current (I_{DQ1})		50		mA
Quiescent Current (I_{DQ3})		75		mA
T_{CH} for $>10^6$ hours MTTF			225	$^\circ\text{C}$

Electrical performance is measured under conditions noted in the electrical specifications table. Specifications are not guaranteed over all recommended operating conditions.

Electrical Specifications

Parameter	Conditions	Min	Typ	Max	Units
Frequency Range		2500		2700	MHz
Driver Quiescent Current			50		mA
Carrier Quiescent Current			75		mA
Gain	$P_{AVG} = 37$ dBm		34.1		dB
P3dB	3 dB PAR compression		45.6		dBm
Power Added Efficiency	$P_{AVG} = 37$ dBm		41.6		%
Raw ACLR	$P_{AVG} = 37$ dBm		-29		dBc

Test conditions unless otherwise noted: $V_{D1,2,3} = +28$ V, $I_{DQ1} = 50$ mA, $I_{DQ3} = 75$ mA, $V_{G2} = -4.4$ V (typical), $T = +25^\circ\text{C}$, single-carrier, 20 MHz LTE signal with 7.8 dB PAR @ 0.01% CCDF, from EVB measurements at 2600 MHz.

Thermal and Reliability Information

Parameter	Test Conditions	Value	Units
Thermal Resistance at Average Power (θ_{JC}), FEA ^{(1) (2)}	$T_{CASE} = +85^{\circ}C$, $T_{CH} = 130^{\circ}C$ CW: $P_{DISS} = 7.3 W$, $P_{OUT} = 5 W$	6.1	$^{\circ}C/W$
Thermal Resistance at Average Power (θ_{JC}), IR ^{(1) (3)}	$T_{CASE} = +85^{\circ}C$, $T_{CH} = 116^{\circ}C$ CW: $P_{DISS} = 7.3 W$, $P_{OUT} = 5 W$	4.2	$^{\circ}C/W$

Notes:

1. Thermal resistance measured to package backside.
2. Finite Element Analysis (FEA) thermal values shall be used to determine performance and reliability. Unless otherwise noted, all thermal references are FEA.
3. Infrared (IR) thermal values are for reference only and cannot be used to determine performance or reliability.

Median Lifetime

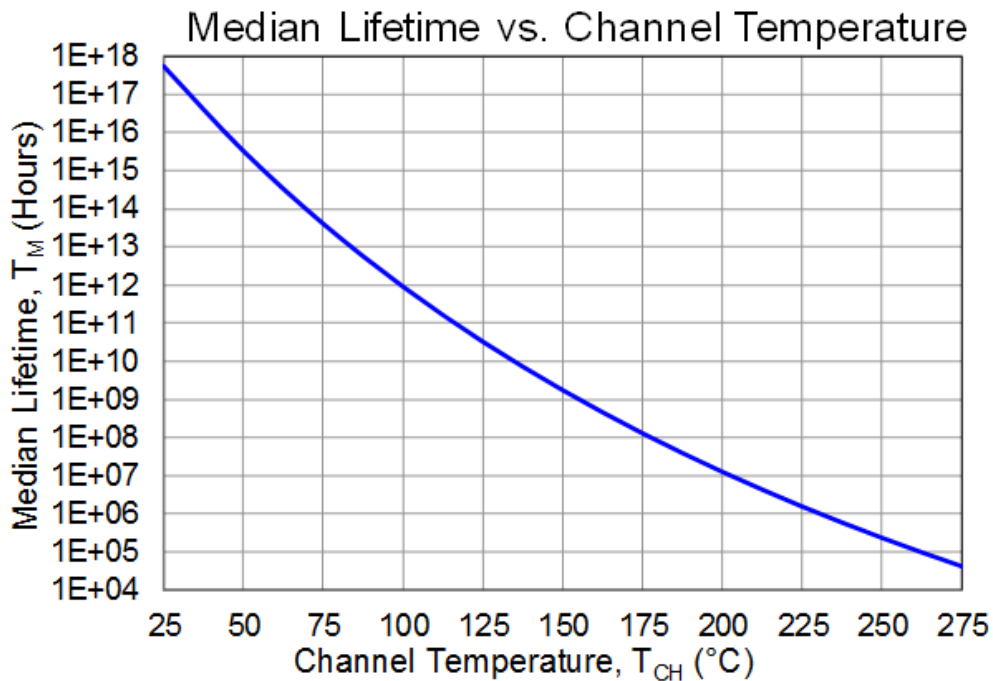

QPA2705 Reference Design

EVB Layout

EVB Schematic

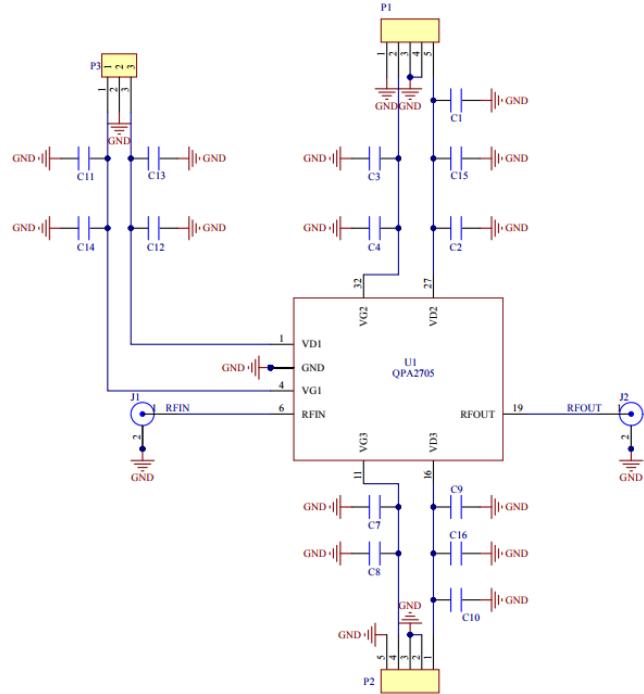
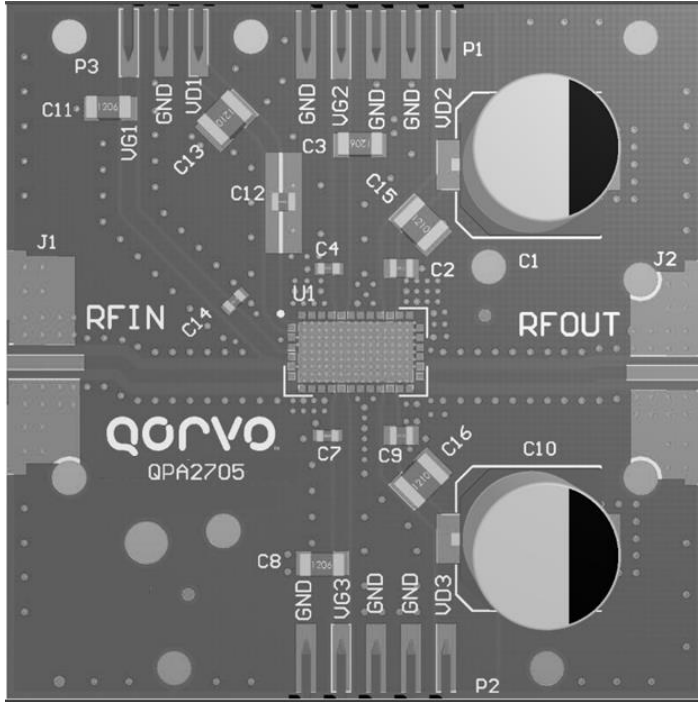

PCB Stackup and Material

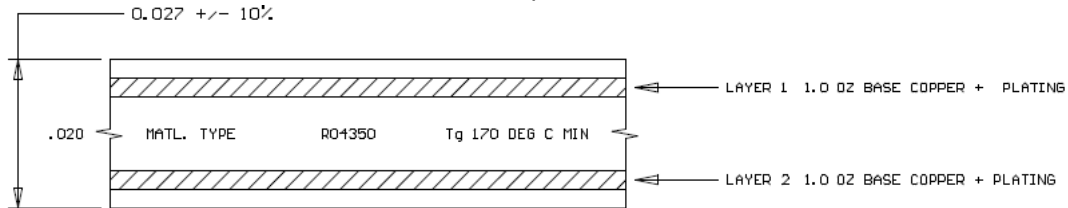

Notes:

1. All dimensions are in inches.
2. PCB is soldered on a 2 inch by 2 inch copper base plate with 0.25 inch thickness.

Bill of Materials – QPA2705 Evaluation Board

Reference Des.	Value	Description	Manuf.	Part No.
C1, C10	220 μ F	Capacitor, 220 μ F	Panasonic	EEEFK1H221P
C2, C9, C12	8.2 pF	Capacitor, 8.2 pF, \pm 0.25 pF, 250 V, C0G	ATC	800A8R2CT250X
C3, C8, C11	4.7 μ F	Capacitor, 4.7 μ F, 10%, 50 V, X7R, 1206	Murata	GRM31CR71H475KA12L
C4, C7, C14	22,000 pF	Capacitor, 22,000 pF, 10%, 50 V, X7R, 0603	Murata	GRM188R71H223KA01D
C13, C15, C16	10 μ F	Capacitor, 10 μ F, 10%, 50 V, X7R, 1210	Murata	GRM32ER71H106KA12L
J1, J2	–	Connector, SMA, 4-Hole Panel Mount Jack	Gigalane	PAF-S00-000
P1, P2	–	Connector, HDR, ST, PLRZD, 5-Pin, 0.100"	ITW Pancon	MPSS100-5-C
P3	–	Connector, HDR, ST, 3-PIN, T/H	Molex	22-28-4033
U1	–	5 W GaN PA Module	Qorvo	QPA2705

Performance Plots

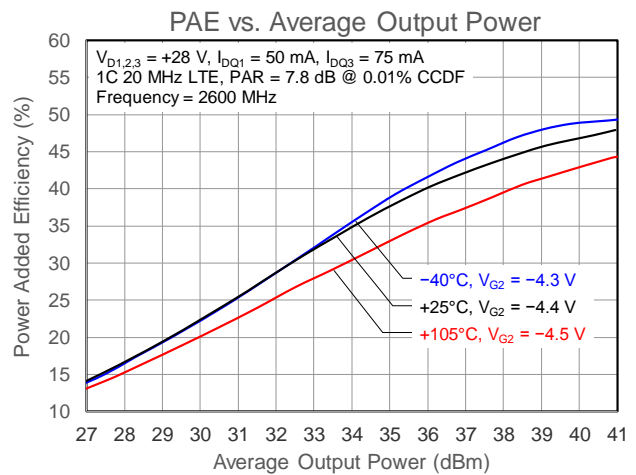
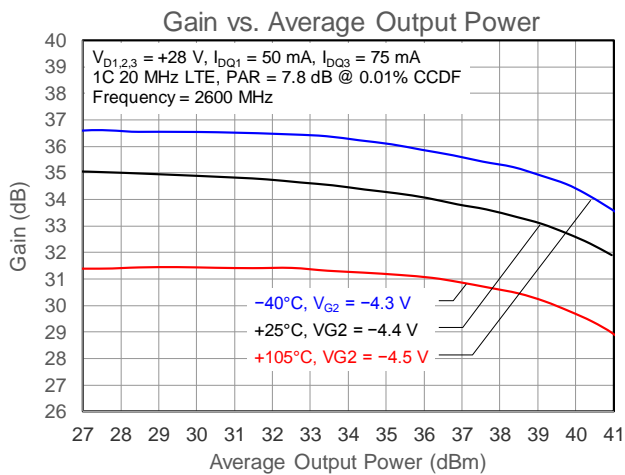
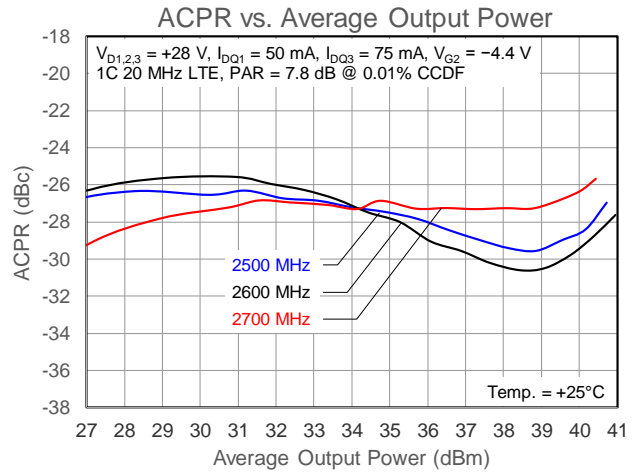
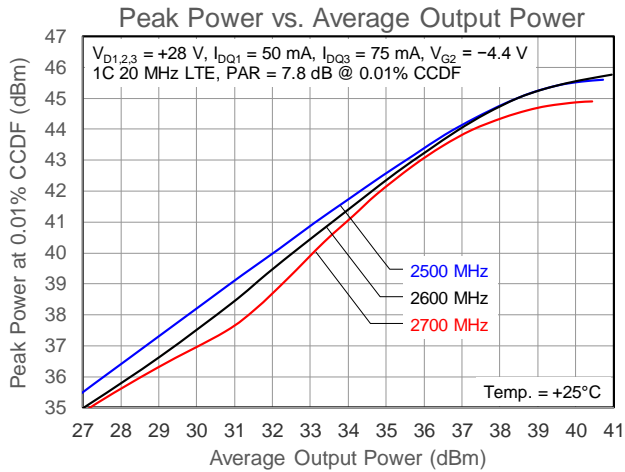
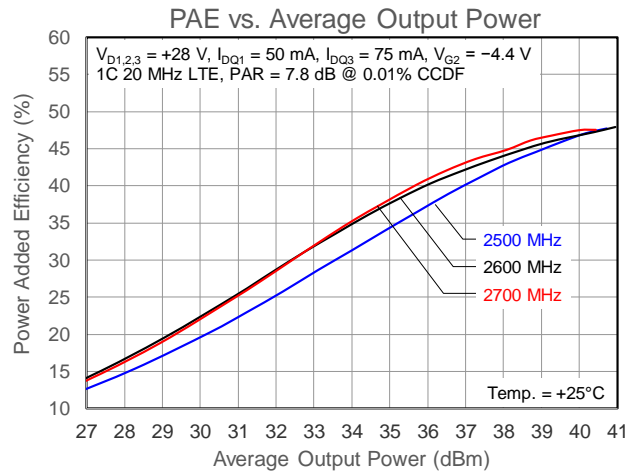
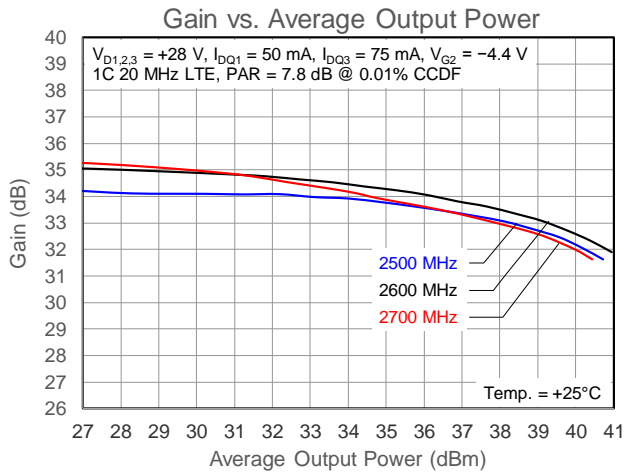

Test conditions unless otherwise noted: $V_{D1,2,3} = +28\text{ V}$, $I_{DQ1} = 50\text{ mA}$, $I_{DQ3} = 75\text{ mA}$, $V_{G2} = -4.4\text{ V}$ (typical), $T = +25^\circ\text{C}$, single-carrier, 20 MHz LTE signal with 7.8 dB PAR @ 0.01% CCDF, from EVB measurements at 2600 MHz.

Performance Plots

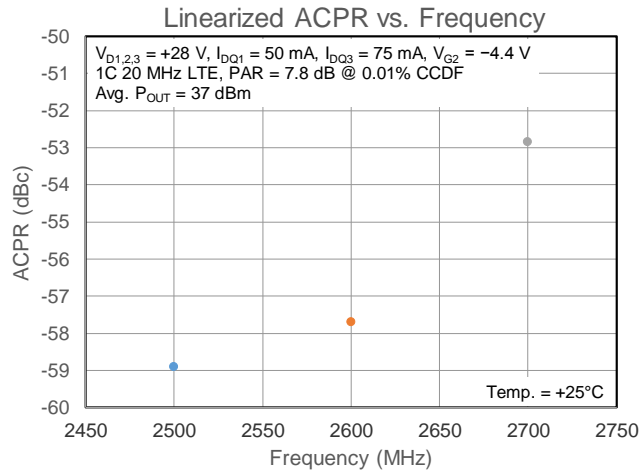
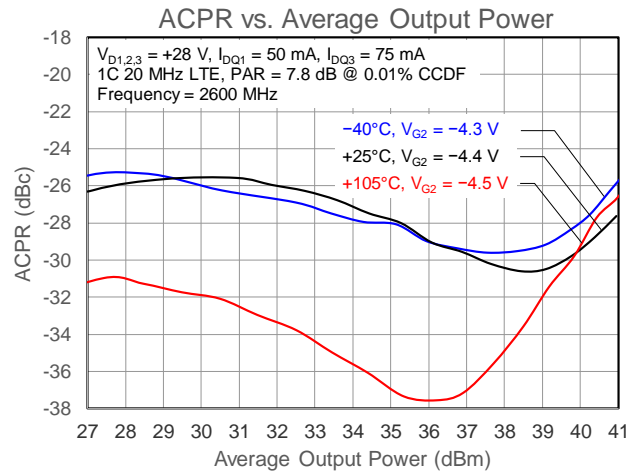
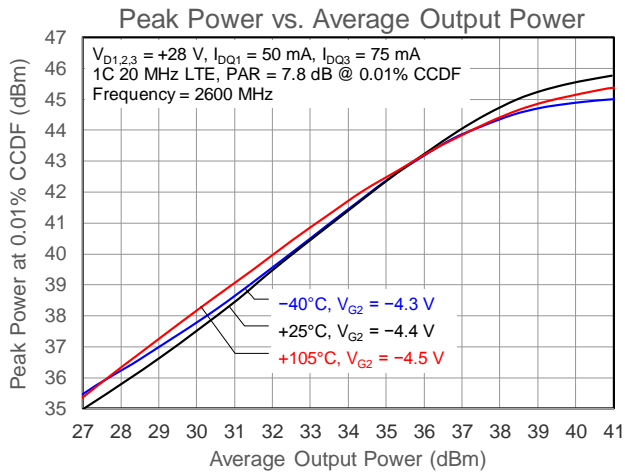

Test conditions unless otherwise noted: $V_{D1,2,3} = +28\text{ V}$, $I_{DQ1} = 50\text{ mA}$, $I_{DQ3} = 75\text{ mA}$, $V_{G2} = -4.4\text{ V}$ (typical), $T = +25^\circ\text{C}$, single-carrier, 20 MHz LTE signal with 7.8 dB PAR @ 0.01% CCDF, from EVB measurements at 2600 MHz.

Pin Configuration and Description

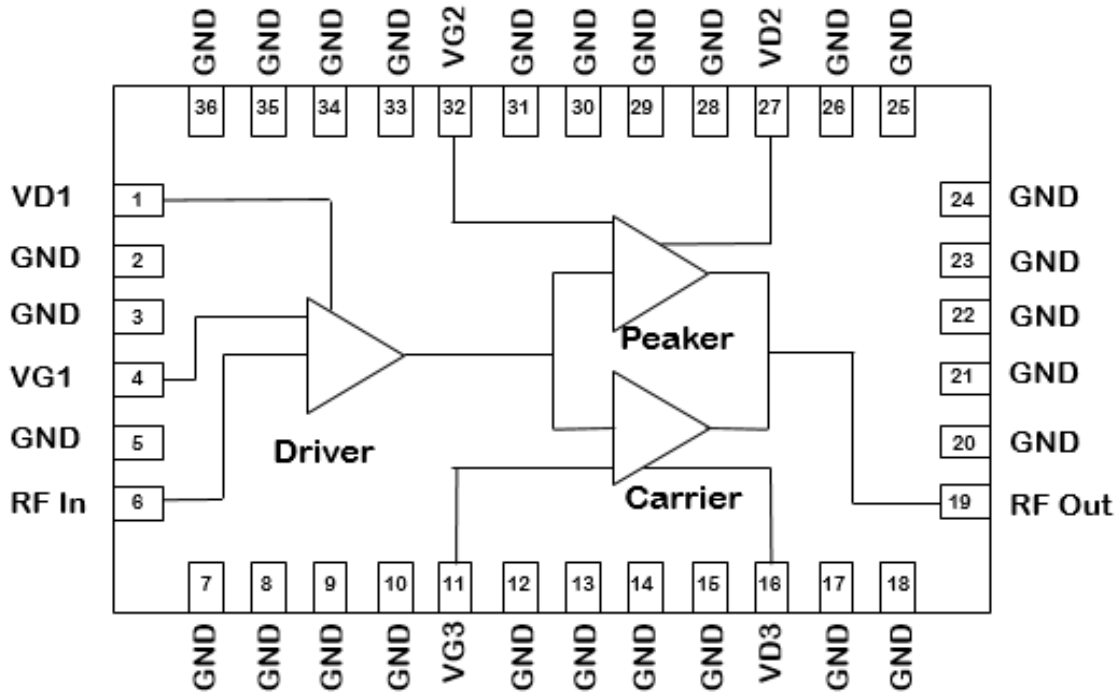

Pin No.	Label	Description
1	VD1	Driver Amplifier, Drain Bias
4	VG1	Driver Amplifier, Gate Bias
6	RF IN	RF Input
11	VG3	Carrier Amplifier, Gate Bias
16	VD3	Carrier Amplifier, Drain Bias
19	RF OUT	RF Output
27	VD2	Peaking Amplifier, Drain Bias
32	VG2	Peaking Amplifier, Gate Bias
2-3, 5, 7-10, 12-15, 17-18, 20-26, 28-31, 33-36	GND	Internal Grounding, recommend connecting to Epad ground DC/RF Ground. Must be soldered to EVB ground plane over array of vias for thermal and RF performance. Solder voids under EPAD will result in excessive junction temperatures causing permanent damage.
EPAD	GND	

Package Marking and Dimensions

Marking: Qorvo Logo
 Part Number – QPA2705
 Date Code – YYWW
 Batch Code – MXXX

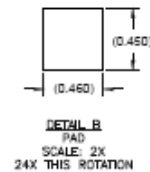
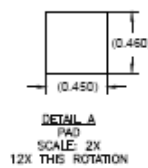
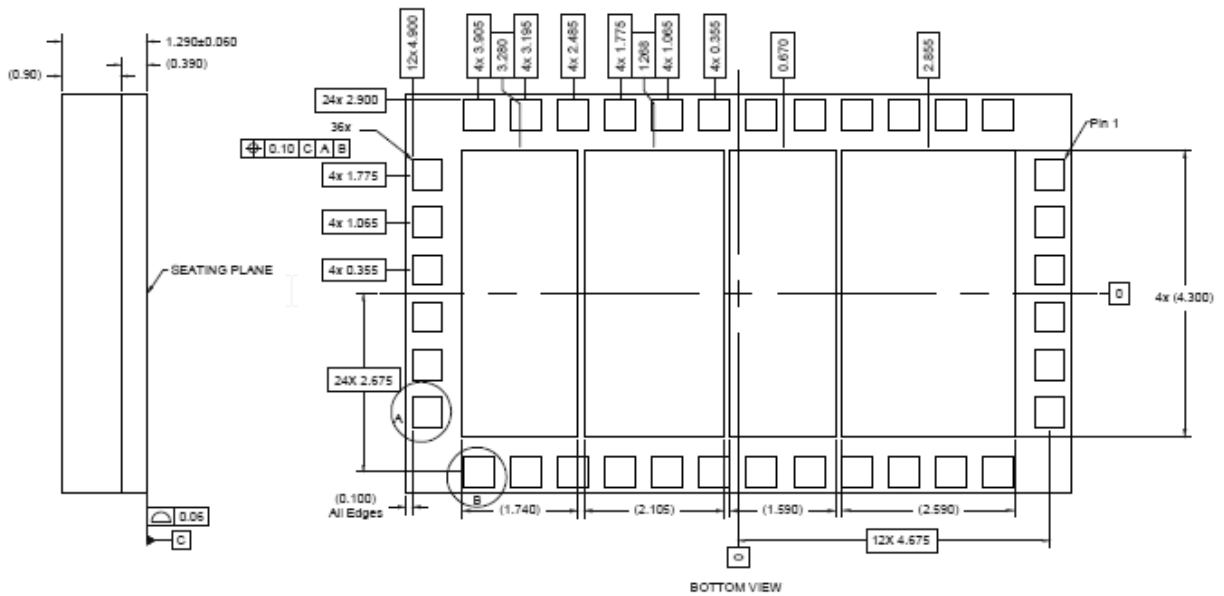

Notes:
 1. All dimensions are in mm. Angles are in degrees.

Mounting Footprint Pattern

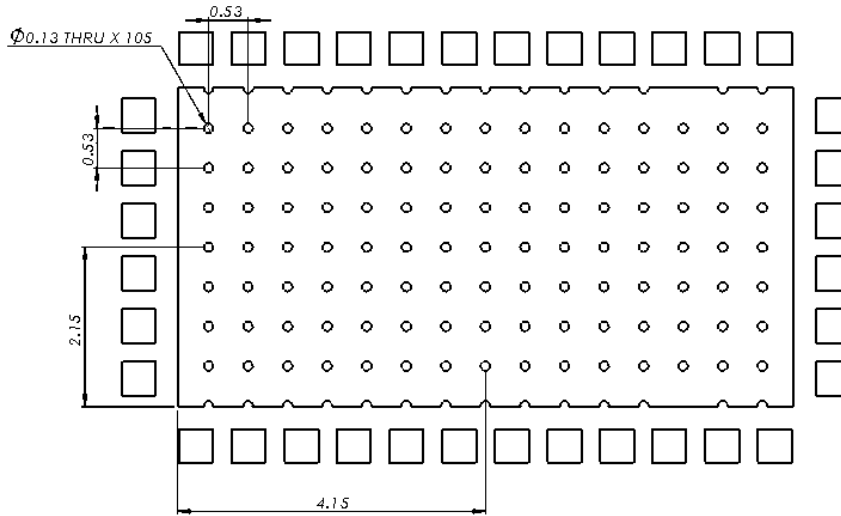

Notes:

1. All dimensions are in mm. Angles are in degrees.
2. Vias are required under the backside paddle of this device for proper RF/DC grounding and thermal dissipation. ALL vias are PTH to ground.
3. Ensure good package backside paddle solder attach for reliable operation and best electrical performance.

Tape and Reel Information – Carrier and Cover Tape Dimensions

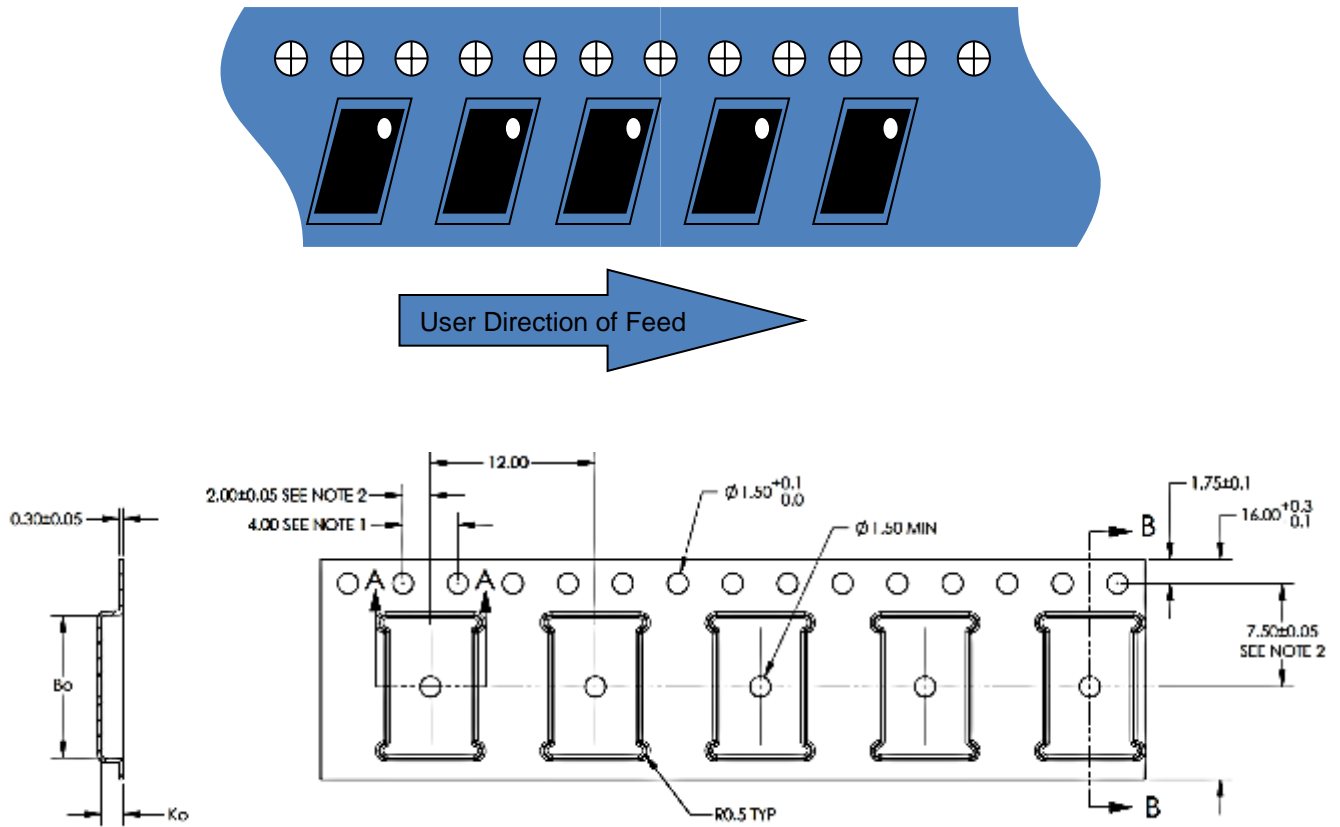

Feature	Measure	Symbol	Size (in)	Size (mm)
Cavity	Length	A0	0.248	6.30
	Width	B0	0.406	10.3
	Depth	K0	0.061	1.55
	Pitch	P1	0.472	12.0
Centerline Distance	Cavity to Perforation – Length Direction	P2	0.079	2.00
	Cavity to Perforation – Width Direction	F	0.295	7.5
Cover Tape	Width	C	0.524	13.3
Carrier Tape	Width	W	0.630	16.0

Tape and Reel Information – Reel Dimensions

Standard T/R size = 2500 pieces on a 13" reel.

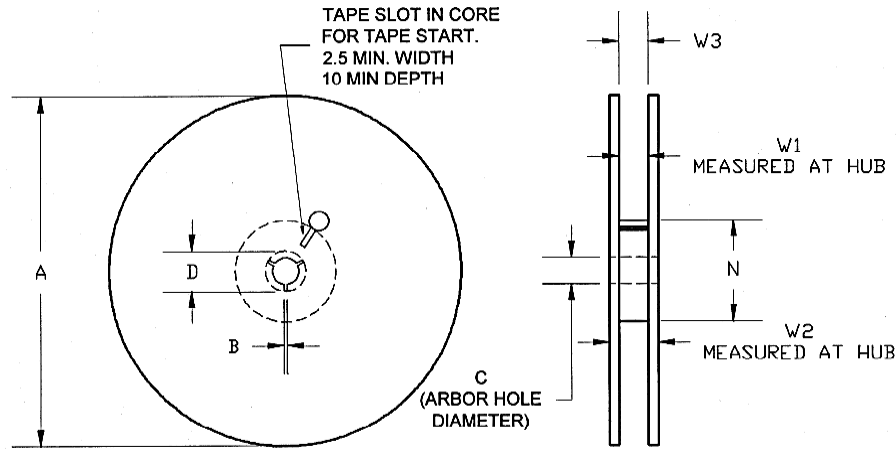

Feature	Measure	Symbol	Size (in)	Size (mm)
Flange	Diameter	A	12.992	330.0
	Thickness	W2	0.874	22.2
	Space Between Flange	W1	0.661	16.8
Hub	Outer Diameter	N	4.016	102.0
	Arbor Hole Diameter	C	0.512	13.0
	Key Slit Width	B	0.079	2.0
	Key Slit Diameter	D	0.787	20.0

Tape and Reel Information – Tape Length and Label Placement

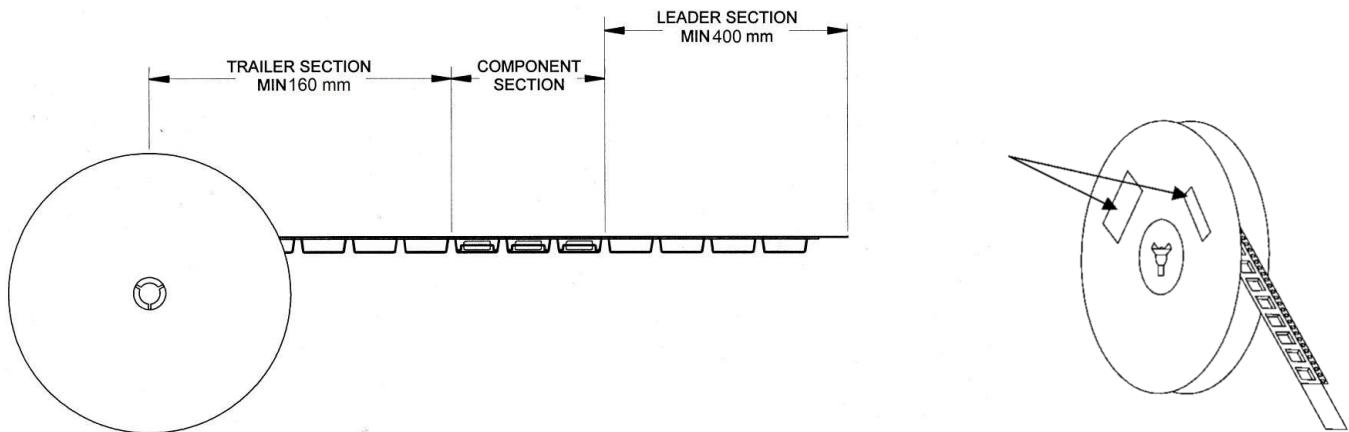

Notes:

1. Empty part cavities at the trailing and leading ends are sealed with cover tape. See EIA 481-1-A.
2. Labels are placed on the flange opposite the sprockets in the carrier tape.

Handling Precautions

Parameter	Rating	Standard
ESD – Human Body Model (HBM)	Class 1B	JEDEC Standard JS-001-2012
ESD – Charged Device Model (CDM)	Class C3	JEDEC Standard JESD22-C101F
MSL – 260°C Convection Reflow	MSL3	JEDEC standard IPC/JEDEC J-STD-020.



Caution!
ESD-Sensitive Device

Solderability

Compatible with both lead-free (260°C maximum reflow temperature) and tin/lead (245°C maximum reflow temperature) soldering processes.

Contact plating: NiAu

RoHS Compliance

This product is compliant with the 2011/65/EU RoHS directive (Restrictions on the Use of Certain Hazardous Substances in Electrical and Electronic Equipment), as amended by Directive 2015/863/EU. This product also has the following attributes:

- Halogen Free (Chlorine, Bromine)
- Antimony Free
- TBBP-A (C₁₅H₁₂Br₄O₂) Free
- PFOS Free
- SVHC Free

Contact Information

For the latest specifications, additional product information, worldwide sales and distribution locations, and information about Qorvo:

Web: www.qorvo.com **Tel:** +1.972.994.8465
Email: info-sales@qorvo.com **Fax:** +1.972.994.8504

For technical questions and application information:

Email: BTSApplications@qorvo.com

Important Notice

The information contained herein is believed to be reliable; however, Qorvo makes no warranties regarding the information contained herein and assumes no responsibility or liability whatsoever for the use of the information contained herein. All information contained herein is subject to change without notice. Customers should obtain and verify the latest relevant information before placing orders for Qorvo products. The information contained herein or any use of such information does not grant, explicitly or implicitly, to any party any patent rights, licenses, or any other intellectual property rights, whether with regard to such information itself or anything described by such information. **THIS INFORMATION DOES NOT CONSTITUTE A WARRANTY WITH RESPECT TO THE PRODUCTS DESCRIBED HEREIN, AND QORVO HEREBY DISCLAIMS ANY AND ALL WARRANTIES WITH RESPECT TO SUCH PRODUCTS WHETHER EXPRESS OR IMPLIED BY LAW, COURSE OF DEALING, COURSE OF PERFORMANCE, USAGE OF TRADE OR OTHERWISE, INCLUDING THE IMPLIED WARRANTIES OF MERCHANTABILITY AND FITNESS FOR A PARTICULAR PURPOSE.**

Without limiting the generality of the foregoing, Qorvo products are not warranted or authorized for use as critical components in medical, life-saving, or life-sustaining applications, or other applications where a failure would reasonably be expected to cause severe personal injury or death.

Copyright 2017 © Qorvo, Inc. | Qorvo is a registered trademark of Qorvo, Inc.