

RECTIFIER DIODE

AR771LT

Repetitive voltage up to **5000 V**
Mean forward current **4020 A**
Surge current **50 kA**

FINAL SPECIFICATION

mar 17 - ISSUE : 4

Symbol	Characteristic	Conditions	T _j [°C]	Value	Unit
BLOCKING					
V _{RRM}	Repetitive peak reverse voltage		150	5000	V
V _{RSM}	Non-repetitive peak reverse voltage		150	5100	V
I _{RRM}	Repetitive peak reverse current	V=VRRM	150	200	mA
CONDUCTING					
I _{F(AV)}	Mean forward current	180° sin ,50 Hz, Th=55°C, double side cooled		4020	A
I _{F(AV)}	Mean forward current	180° sin ,50 Hz, Tc=85°C, double side cooled		3690	A
I _{FSM}	Surge forward current	Sine wave, 10 ms without reverse voltage	150	50	kA
I ² t	I ² t			12500 x 1E3	A²s
V _{FM}	Forward voltage	Forward current = 3000 A	25	1,45	V
V _{F(TO)}	Threshold voltage		150	0,80	V
r _F	Forward slope resistance		150	0,170	mohm
SWITCHING					
t _{rr}	Reverse recovery time	I= 1600 A	125	75,5	µs
Q _{rr}	Reverse recovery charge	di/dt= 5A/µs		5594	µC
I _{rr}	Peak reverse recovery current			167	A
MOUNTING					
R _{th(j-h)}	Thermal impedance, DC	Junction to heatsink, double side cooled		9,5	°C/kW
R _{th(c-h)}	Thermal impedance	Case to heatsink, double side cooled		2	°C/kW
T _j	Operating junction temperature			-30 / 150	°C
F	Mounting force			46.0 / 54.0	kN
	Mass			1700	g

ORDERING INFORMATION : AR771LT S 50

standard specification VRRM/100

SWITCHING CHARACTERISTICS

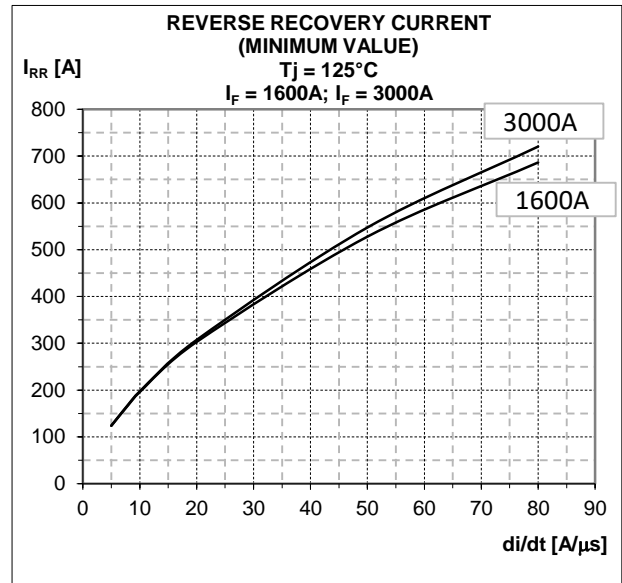
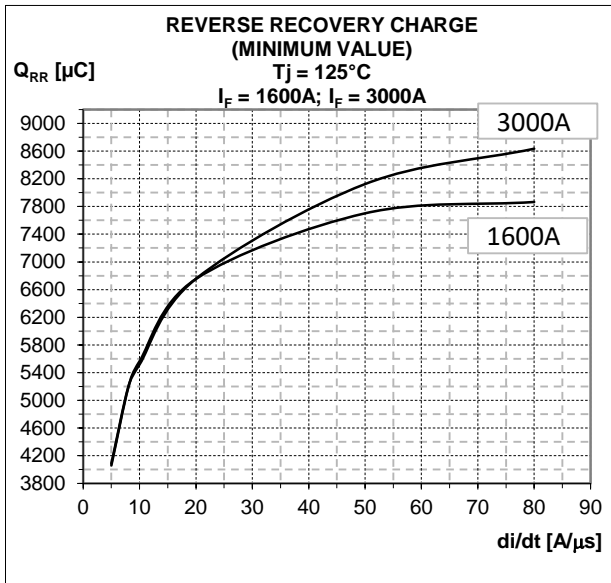
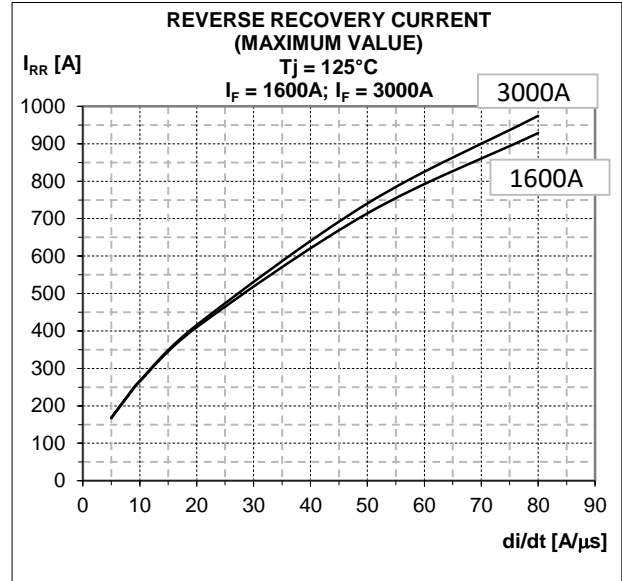
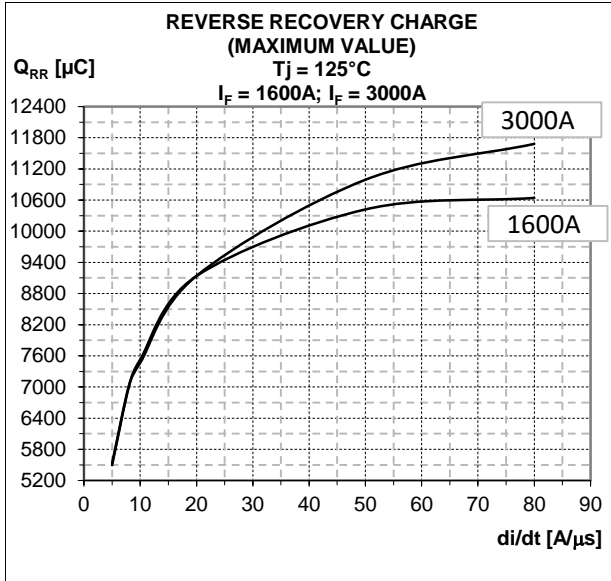

$$t_a = \frac{I_{RR}}{di/dt}$$

$$t_b = t_{RR} - t_a$$

$$S = \frac{t_b}{t_a}$$

$$E_{OFF} = V_R * \left[Q_{RR} - \left(I_{RR} * \frac{t_a}{2} \right) \right]$$

$$Q_{RR} = I_{RR} * \frac{t_{RR}}{2}$$

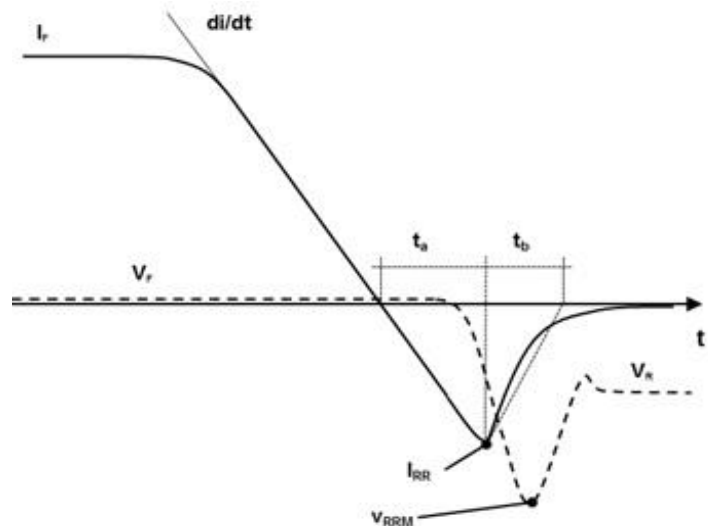

AR771LT RECTIFIER DIODE



FINAL SPECIFICATION mar 17 - ISSUE : 4

FORWARD CHARACTERISTIC
T_j = 150 °C

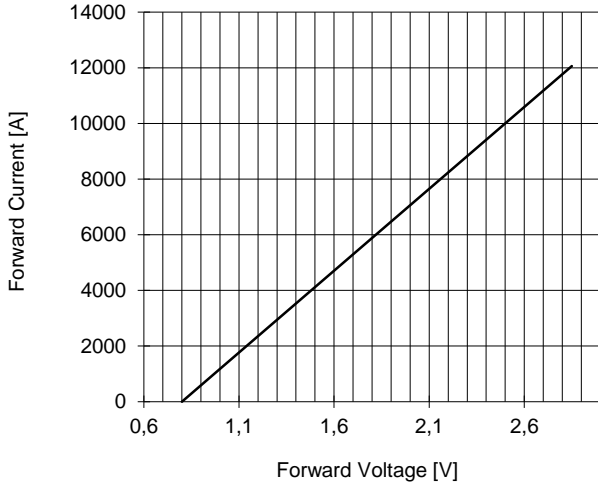

SURGE CHARACTERISTIC
T_j = 150 °C

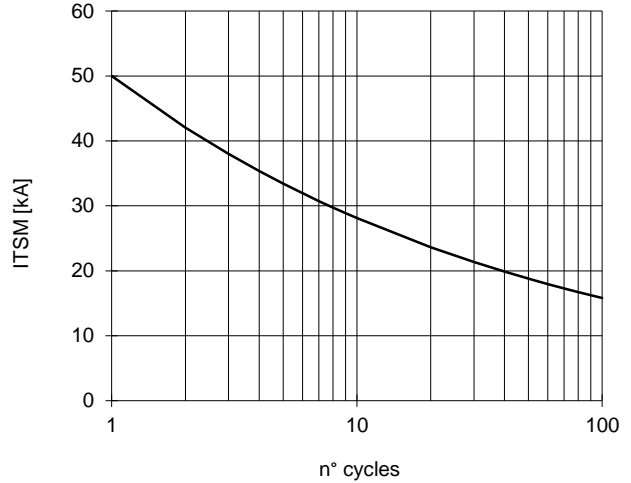

TRANSIENT THERMAL IMPEDANCE
DOUBLE SIDE COOLED

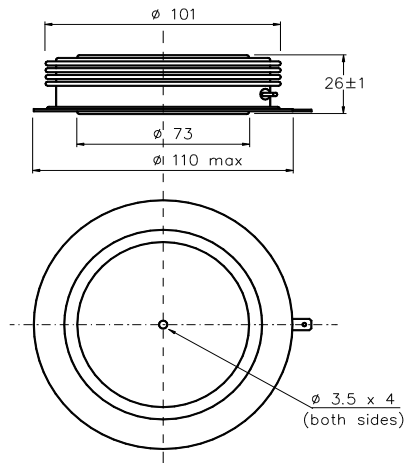
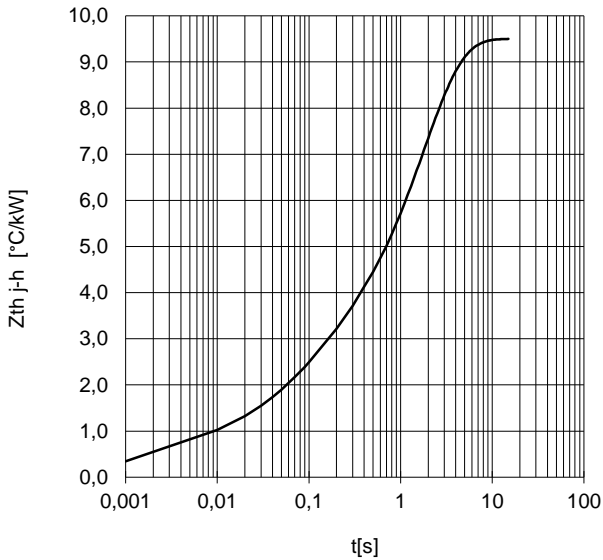

Dimensions
in mm



All the characteristics given in this data sheet are guaranteed only with uniform clamping force, cleaned and lubricated heatsink, surfaces with flatness < .03 mm and roughness < 2 μm.

In the interest of product improvement POSEICO SpA reserves the right to change any data given in this data sheet at any time without previous notice.

If not stated otherwise the maximum value of ratings (symbols over shaded background) and characteristics is reported.

Distributed by

