



LR8XXYY

Preliminary

CMOS IC

150mA DUAL LDO REGULATOR

DESCRIPTION

The UTC **LR8XXYY** Series are a low dropout regulator with high output voltage accuracy, low quiescent current, low dropout, and high ripple rejection. This regulator is based on a CMOS process. Each of these regulator ICs contains dual LDO regulator, both of them includes a voltage reference, an error amplifier, resistors for setting Output Voltage, a current limit circuit, and a chip enable circuit.

The UTC **LR8XXYY** Series exhibit ultra excellent line transient response and load transient response, thus they are very suitable for the power supply for hand-held communication equipment.

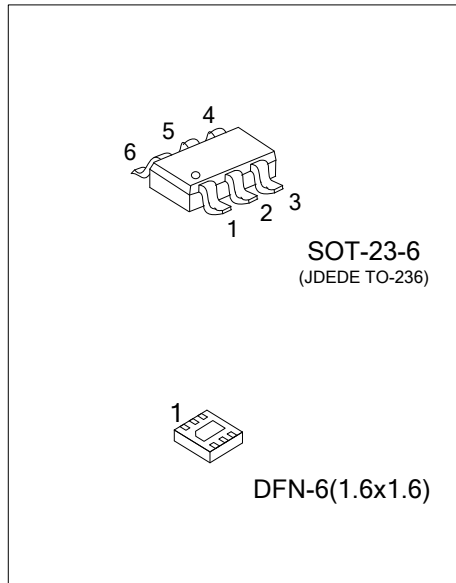

FEATURES

- * Supply Current: TYP. 40 μ A (VR1, VR2)
- * Standby Mode: TYP. 0.1 μ A (VR1, VR2)
- * Low Dropout Voltage: TYP. 0.22V($I_{OUT}=150mA, V_{OUT}=2.8V$)
- * High Ripple Rejection: TYP. 70dB (f=1kHz), TYP. 65dB (f=10kHz)
- * High Output Voltage Accuracy: $\pm 1.0\%$
- * Low Temperature-Drift Coefficient of Output Voltage:
TYP. $\pm 80ppm/^{\circ}C$
- * Excellent Line Regulation: TYP. 0.02%/V
- * Built-in Fold Back Protection Circuit TYP. 40mA
(Current at short mode)
- * Ceramic capacitors are recommended to be used with this IC
0.22 μ F or more

ORDERING INFORMATION

Ordering Number	Package	Packing
LR8XXYYBG-AE6-R	SOT-23-6	Tape Reel
LR8XXYYBG-K06-1616-R	DFN-6(1.6x1.6)	Tape Reel

Note: XXYY: Output Voltage, refer to Marking Information.

<p>LR8XXYYBG-AE6-R</p> <p>(1)Packing Type (2)Package Type (3)Green Package (4)Discharge Function (5)Voltage Code at V_{OUT2} (6)Voltage Code at V_{OUT1}</p>	<p>(1) R: Tape Reel (2) AE6: SOT-23-6, K06-1616: DFN-6(1.6x1.6) (3) G: Halogen Free and Lead Free (4) B: without auto-discharge function at off state (5) YY: refer to Marking Information (6) XX: refer to Marking Information</p>
--	---

MARKING INFORMATIONS

PACKAGE	VOLTAGE CODE				MARKING
	CODE	X	CODE	Y	
SOT-23-6	1	1.2V	1	1.2V	
	2	1.5V	2	1.5V	
	3	1.8V	3	1.8V	
	4	2.0V	4	2.0V	
DFN-6(1.6×1.6)	5	2.5V	5	2.5V	
	6	2.8V	6	2.8V	
	7	3.0V	7	3.0V	
	8	3.3V	8	3.3V	
	9	3.6V	9	3.6V	

PIN CONFIGURATION

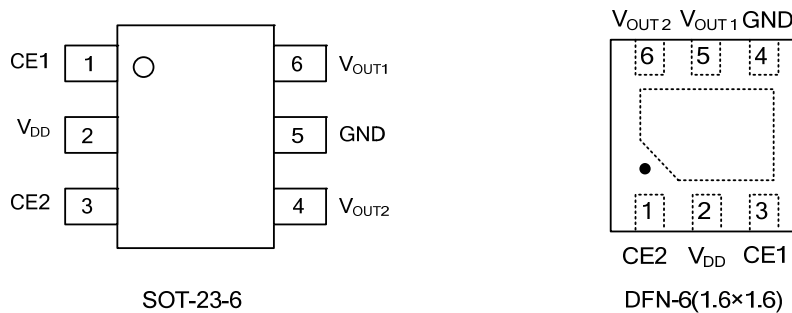

PIN DESCRIPTION

PIN NO.		PIN NAME	DESCRIPTION
SOT-23-6	DFN-6(1.6×1.6)		
1	3	CE1	Chip Enable Pin 1 ("H" Active)
2	2	V _{DD}	Input Pin
3	1	CE2	Chip Enable Pin 2 ("H" Active)
4	6	V _{OUT2}	Output Pin 2
5	4	GND	Ground Pin
6	5	V _{OUT1}	Output Pin 1

■ BLOCK DIAGRAM

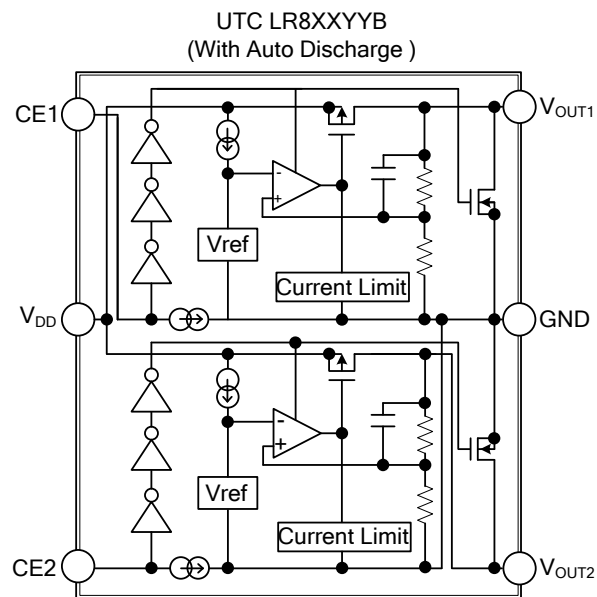

■ ABSOLUTE MAXIMUM RATINGS

PARAMETER		SYMBOL	RATINGS	UNIT
Input Voltage		V_{IN}	6.0	V
Input Voltage (CE Pin)		V_{CE}	-0.3 ~ 6.0	V
Output Voltage		V_{OUT}	-0.3 ~ $V_{IN}+0.3$	V
Output Current 1		I_{OUT1}	180	mA
Output Current 2		I_{OUT2}	180	mA
Power Dissipation	SOT-23-6	P_D	420	mW
	DFN-6(1.6×1.6)		138	mW
Operating Temperature Range		T_{OPR}	-40 ~ +85	°C
Storage Temperature Range		T_{STG}	-55 ~ +125	°C

Note: Absolute maximum ratings are those values beyond which the device could be permanently damaged. Absolute maximum ratings are stress ratings only and functional device operation is not implied.

■ ELECTRICAL CHARACTERISTICS

(V_{IN} =Set $V_{OUT}+1.0V$ for V_{OUT} options greater than 1.5V, $V_{IN}=2.5V$ for $V_{OUT}\leq 1.5V$, $I_{OUT}=1mA$, $C_{IN}=C_{OUT}=0.22\mu F$ unless otherwise noted. ($T_A=25^\circ C$))

PARAMETER	SYMBOL	TEST CONDITIONS	MIN	TYP	MAX	UNIT
Output Voltage	V_{OUT}	$T_A=25^\circ C$	$V_{OUT}>2.0V$	x 0.99	x 1.01	V
			$V_{OUT}\leq 2.0V$	-20	+20	mV
Output Current	I_{OUT}		150			mA
Load Regulation	$\frac{\Delta V_{OUT}}{\Delta I_{OUT}}$	$1mA\leq I_{OUT}\leq 150mA$	$0.8V\leq V_{OUT}<1.1V$	10		mV
			$1.1V\leq V_{OUT}<1.6V$	15		
			$1.6V\leq V_{OUT}<2.0V$	15		
			$2.0V\leq V_{OUT}\leq 3.6V$	15		
Dropout Voltage	V_{DIF}	$I_{OUT}=150mA$	$V_{OUT}=0.8V$	0.63		V
			$V_{OUT}=0.9V$	0.55		
			$1.0V\leq V_{OUT}<1.2V$	0.50		
			$1.2V\leq V_{OUT}<1.4V$	0.42		
			$1.4V\leq V_{OUT}<1.7V$	0.37		
			$1.7V\leq V_{OUT}<2.1V$	0.30		
			$2.1V\leq V_{OUT}<2.5V$	0.25		
			$2.5V\leq V_{OUT}<3.0V$	0.23		
Supply Current	I_{SS}	$I_{OUT}=0mA$		50	60	μA
Supply Current (Standby)	$I_{STANDBY}$	$V_{CE}=0V$		0.1		μA
Line Regulation	$\frac{\Delta V_{OUT}}{\Delta V_{IN}}$	Set $V_{OUT}+0.5V\leq V_{IN}\leq 5.0V$		0.02		%/V
Ripple Rejection	RR	f=1kHz, Ripple 0.2Vp-p, V_{IN} =Set $V_{OUT}+1.0V$, $I_{OUT}=30mA$ (In case $V_{OUT}\leq 2.0V$, $V_{IN}=3.0V$)		70		dB
Input Voltage (Note 1)	V_{IN}				5.25	V
Output Voltage Temperature Coefficient	$\frac{\Delta V_{OUT}}{\Delta T_{OPT}}$	$-40^\circ C\leq T_a\leq 85^\circ C$		± 80		ppm
Short Current	I_{LIM}	$V_{OUT}=0V$		40		mA

■ ELECTRICAL CHARACTERISTICS (Cont.)

PARAMETER	SYMBOL	TEST CONDITIONS	MIN	TYP	MAX	UNIT
CE Pull-down Current	I_{PD}			0.3		μA
CE Input Voltage "H"	V_{CEH}		1.0			V
CE Input Voltage "L"	V_{CEL}				0.4	V
Output Noise	en	BW=10Hz ~ 100kHz		60		μV_{rms}
Nch ON Resistance For Auto Discharge (B/C/E Version Only)	R_{LOW}	$V_{IN}=4.0V, V_{CE}=0V$	C Ver. (VR2)			Ω
			Others			Ω

Notes: 1. The specification in **boldface** is checked and guaranteed by design engineering.

- All of unit are tested and specified under load conditions such that $T_J \approx T_A = 25^\circ C$ except for Output Noise, Ripple Rejection and Output Voltage Temperature Coefficient items.
- The maximum Input Voltage of the ELECTRICAL CHARACTERISTICS is 5.25V. In case of exceeding this specification, the IC must be operated on condition that the Input Voltage is up to 5.5V and the total operating time is within 500hrs.

■ TYPICAL APPLICATION CIRCUIT

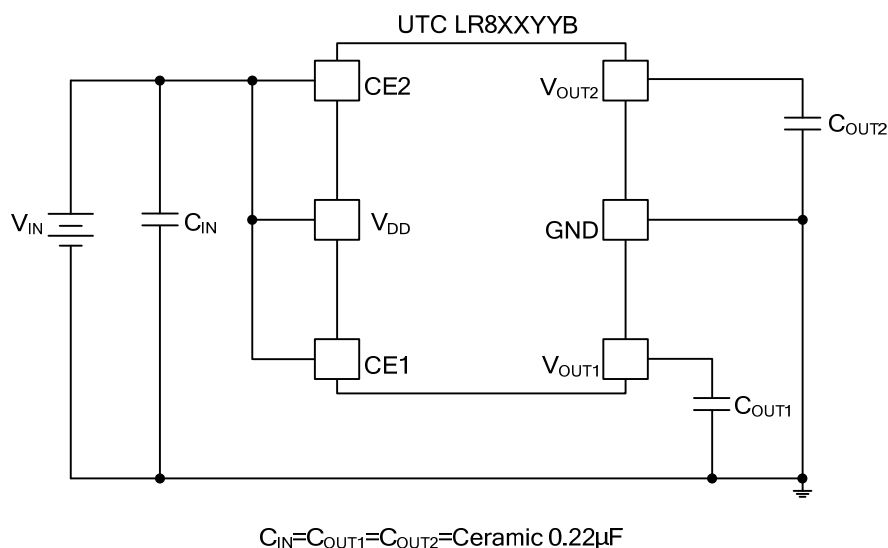

UTC assumes no responsibility for equipment failures that result from using products at values that exceed, even momentarily, rated values (such as maximum ratings, operating condition ranges, or other parameters) listed in products specifications of any and all UTC products described or contained herein. UTC products are not designed for use in life support appliances, devices or systems where malfunction of these products can be reasonably expected to result in personal injury. Reproduction in whole or in part is prohibited without the prior written consent of the copyright owner. The information presented in this document does not form part of any quotation or contract, is believed to be accurate and reliable and may be changed without notice.