

# PMW3330DM-TZQU: Optical Gaming Navigation Sensor

## General Description:

PMW3330DM-TZQU is PixArt Imaging's mid-range gaming sensor which comprises of navigation sensor and IR LED integrated in a 16pin molded lead-frame DIP package. It provides best in class gaming experience with the enhanced features of high speed, high resolution, high accuracy and selectable lift detection height to fulfill professional gamers' need. The sensor comes with self-adjusting variable frame rate algorithm to enable wireless gaming application. It is designed to be used with LM19-LSI lens to achieve optimum performance.

## Key Features:

- Integrated 16 pin molded lead-frame DIP package with IR LED
- Operating Voltage: 1.8V - 2.1V
- Lift detection options
  - 2mm
  - 3mm
  - Manual Lift Cut Off Calibration
- High speed motion detection 150ips (typical) and acceleration 30g (max).
- Selectable resolutions up to 7200cpi with 50cpi step size
- Resolution error of 3% (typical)
- Four wire serial port interface (SPI)
- External interrupt output for motion detection
- Internal oscillator — no clock input needed
- Self-adjusting variable frame rate for optimum power performance in wireless application
- Customizable response time and downshift time for rest modes
- Angle snapping

## Applications:

- Wired and Wireless Optical gaming mice
- Integrated input devices
- Battery-powered input devices

## Key Sensor Parameters:

Parameter	Value
Supply Voltage	1.8V ~ 2.1V
Interface	4 wire Serial Port Interface (SPI)
Tracking Speed	150ips (typical)
Acceleration	30g
CPI Resolution	Up to 7200
Frame Rate	Up to 8000 fps
Operating Current	VDD = 2.0V Run Avg.: 7.60mA Rest1: 1.20mA Rest2: 32uA Rest3: 18uA
System Clock	68MHz
Package Type	16 pin molded lead-frame DIP package with integrated IR LED
Lens Magnification	1:1

## Ordering Information:

Part Number	Package Type
PMW3330DM-TZQU	16pin-DIP
LM19-LSI	Lens



## 1.0 System Level Description

This section covers PMW3330DM-TZQU’s guidelines and recommendations in term of sensor, lens & PCB assemblies.

### 1.1 Pin Configuration

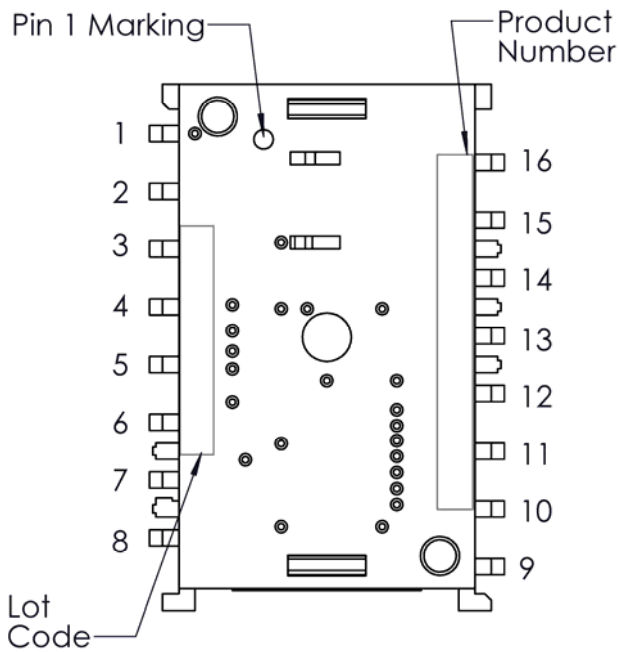

Pin No.	Function	Symbol	Type	Description
1	NA	NC	NC	(Float)
2	NA	NC	NC	(Float)
3	Supply Voltage and I/O Voltage	VDDPIX	Power	LDO output for selective analog circuit
4		VDD	Power	Input power supply
5		VDDIO	Power	I/O reference voltage
6	NA	NC	NC	(Float)
7	Reset control	NRESET	Input	Chip reset(active low)
8	Ground	GND	GND	Ground
9	Motion Output	MOTION	Output	Motion detect
10	4-wire SPI communication	SCLK	Input	Serial data clock
11		MOSI	Input	Serial data input
12		MISO	Output	Serial data output
13		NCS	Input	Chip select(active low)
14	NA	NC	NC	(Float)
15	LED	LED_P	Input	LED Anode
16	NA	NC	NC	(Float)

Figure 1. Device output pins

Table 1. PMW3330DM-TZQU Pin Description

Items	Marking	Remark
Product Number	PMW3330DM-TZQU	
Lot Code	AYWWXXXXX	A : Assembly house Y: Year WW: Week XXXXX: PixArt reference

1.2 Package Outline Drawing

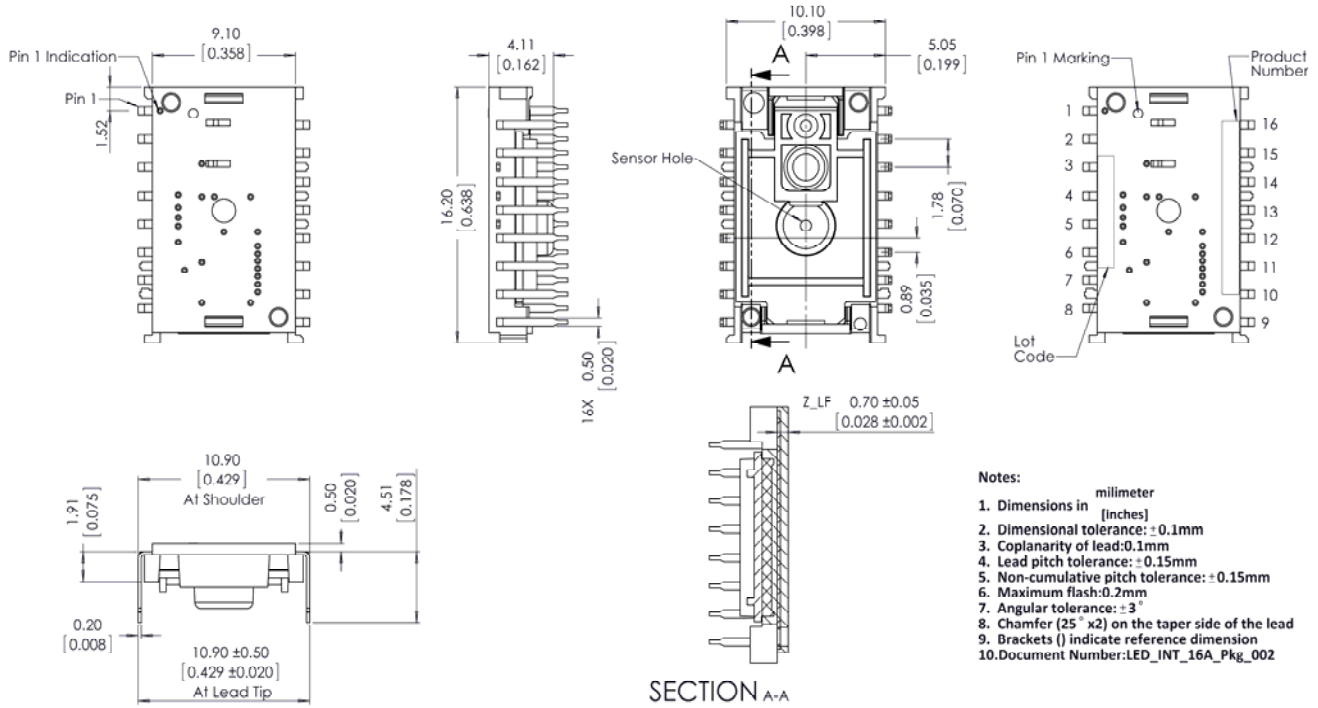

Figure 2. Packages Outline Drawing

**CAUTION:** It is advised that normal static discharge precautions be taken in handling and assembling of this component to prevent damage and/or degradation which may be induced by ESD.

1.3 Assembly Drawings

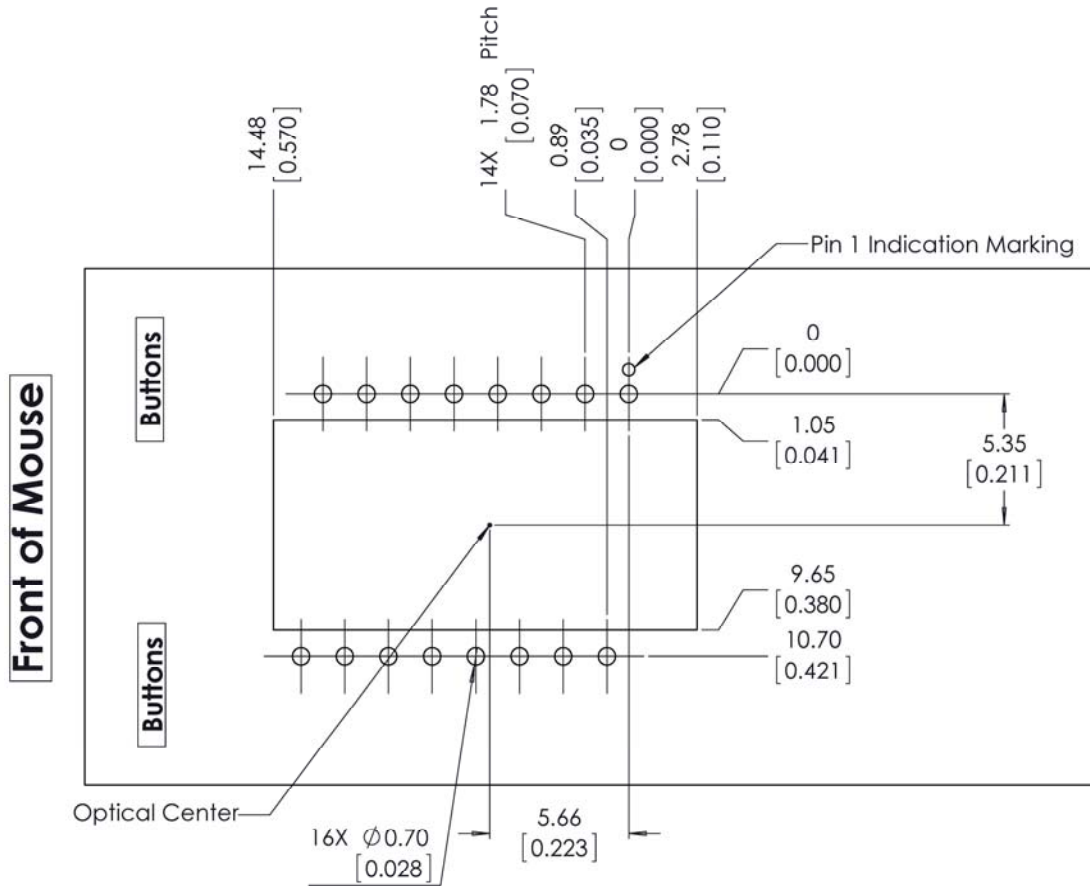

Figure 3. Recommended sensor orientation, mechanical cutouts and spacing (Top View)

1.4 Reference Schematics

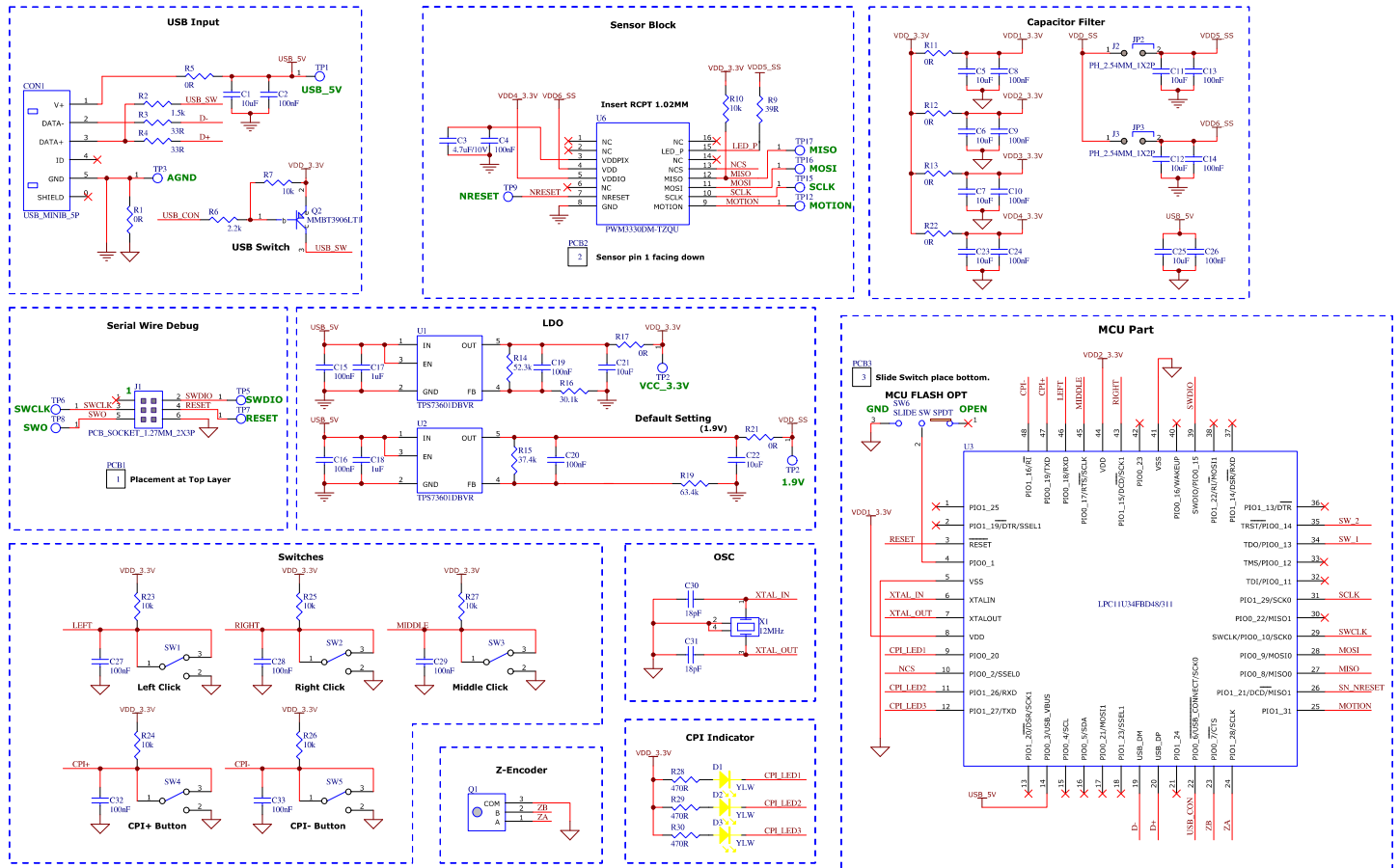

Figure 4. Schematic diagram for interface between PMW3330DM-TZQU and microcontroller on a wired solution

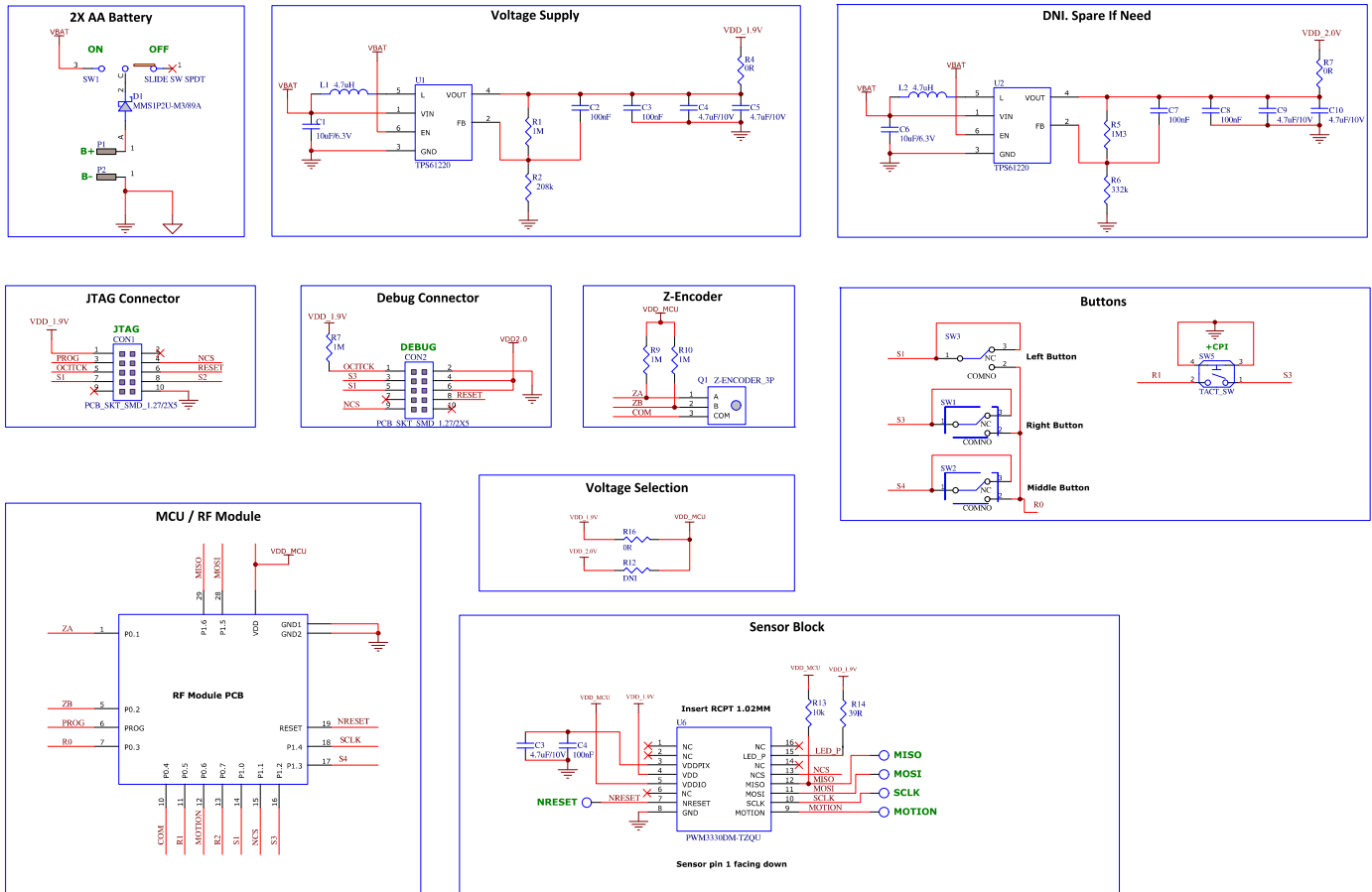

Figure 5. Schematic diagram for interface between PMW3330DM-TZQU and microcontroller in a wireless solution

## 1.5 Electrical Specifications

### Regulatory Requirements

- Passes FCC “Part15, Subpart B, Class B”, “CISPR 22 1997 Class B” and worldwide analogous emission limits when assembled into a mouse with shielded cable and following PixArt Imaging’s recommendations.
- Passes IEC 62471: 2006 Photo biological safety of lamps and lamp systems

## 1.6 Absolute Maximum Ratings

Table 2: Absolute Maximum Ratings

Parameter	Symbol	Minimum	Maximum	Units	Notes
Storage Temperature	$T_S$	-40	85	°C	
Lead Solder Temperature	$T_{SOLDER}$		260	°C	For 7 seconds, 1.6mm below seating plane.
Supply Voltage	$V_{DD}$	-0.5	2.10	V	
	$V_{DDIO}$	-0.5	3.60	V	
ESD (Human Body Model)			2	kV	All pins
Input Voltage	$V_{IN}$	-0.5	3.6	V	All I/O pins.

## 1.7 Recommended Operating Conditions

Table 3: Recommended Operating Condition

Parameter	Symbol	Min	Typ.	Max	Units	Notes
Operating Temperature	$T_A$	0		40	°C	
Power Supply Voltage	$V_{DD}$	1.80	2.0	2.10	V	excluding supply noise
	$V_{DDIO}$	1.80	2.0	3.60	V	excluding supply noise. (VDDIO must be same or greater than VDD)
Power Supply Rise Time	$t_{RT}$	0.15		20	ms	0 to VDD min
Supply Noise (Sinusoidal)	$V_{NA}$			100	mVp-p	10 kHz — 75 MHz
Serial Port Clock Frequency	$f_{SCLK}$			2.25	MHz	50% duty cycle
Distance from Lens Reference Plane to Tracking Surface	Z	2.2	2.4	2.6	mm	
Speed	S		150		ips	220ips on QCK, Vespula Speed, Vespula Control and FUNC 1030 surfaces
Resolution error	$R_{esErr}$		3		%	Up to 150ips on QCK with 3000 cpi
Acceleration	A			30	g	In run mode

## 1.8 DC Electrical Specifications

Table 4. DC Electrical Specifications

Electrical characteristics, over recommended operating conditions. Typical values at 25 °C,  $V_{DD} = 2.0\text{ V}$ ,  $V_{DDIO} = 2.0\text{ V}$

Parameter	Symbol	Min	Typical	Max	Units	Notes
DC Supply Current	$I_{DD\_RUN\_VFR1}$ [4k FPS]		7.0		mA	Average current, including LED current at 1ms motion polling on Qck surface
	$I_{DD\_RUN\_VFR2}$ [8k FPS]		12.8		mA	
	$I_{DD\_REST1}$		1.2		mA	
	$I_{DD\_REST2}$		32		uA	
	$I_{DD\_REST3}$		18		uA	
Power Down Current	$I_{PD}$		3		μA	
Input Low Voltage	$V_{IL}$			$0.3 \times V_{DDIO}$	V	SCLK, MOSI, NCS
Input High Voltage	$V_{IH}$	$0.7 \times V_{DDIO}$			V	SCLK, MOSI, NCS
Input Hysteresis	$V_{I\_HYS}$		100		mV	SCLK, MOSI, NCS
Input Leakage Current	$I_{leak}$		±1	±10	μA	$V_{in}=V_{DDIO}$ or 0V, SCLK, MOSI, NCS
Output Low Voltage	$V_{OL}$			0.45	V	$I_{out}=1\text{mA}$ , MISO, MOTION
Output High Voltage	$V_{OH}$	$V_{DDIO} - 0.45$			V	$I_{out}=-1\text{mA}$ , MISO, MOTION



### 1.9 Registers Table

PMW3330DM-TZQU registers are accessible via the serial port. The registers are used to read motion data and status as well as to set the device configuration.

Address	Register	Access: R = Read, W = Write, Read / Write= RW	Default Value
0x00	Product_ID	R	0x45
0x02	Motion	RW	0x00
0x03	Delta_X_L	R	0x00
0x04	Delta_X_H	R	0x00
0x05	Delta_Y_L	R	0x00
0x06	Delta_Y_H	R	0x00
0x07	SQUAL	R	0x00
0x08	Pixel_Sum	R	0x00
0x09	Maximum_Pixel	R	0x00
0x0A	Minimum_Pixel	R	0x00
0x0B	Shutter_Lower	R	0x12
0x0C	Shutter_Upper	R	0x00
0x15	Chip_Observation	RW	0x80
0x16	Burst_Motion_Read	R	0x00
0x19	Pix_Grab_Status	R	0x00
0x1B	Resolution	RW	0x3B
0x1E	Angle_Snap	RW	0x04
0x20	Axis_Control	RW	0x00
0x22	LiftCutoff_Calibration_Control	RW	0x10
0x23	LiftCutoff_Calibration_Status	RO	0x00
0x24	Run_DownShift	RW	0x08
0x25	Rest1_Period	RW	0x01
0x26	Rest1_Downshift	RW	0x4F
0x27	Rest2_Period	RW	0x19
0x28	Rest2_Downshift	RW	0x5E
0x29	Rest3_Period	RW	0x3F
0x32	Pix_Grab	RW	0x00
0x3A	Power_Up_Reset	W	N/A
0x3B	Shutdown	W	N/A
0x3F	Inv_Product_ID	R	0xBA
0x40	Config	RW	0x00
0x4E	Min_Squal_Run_LCC_Paf	RW	0x0F
0x70	LCC_Msq	RO	0x00
0x71	LCC_Sqth	RO	0x00