

规格书编号

SPEC NO :

产品规格书

SPECIFICATION

CUSTOMER 客户: _____
PRODUCT 产品: _____ SAW FILTER _____
MODEL NO 型号: _____ HDF433.96M SMD-3 _____
MARKING 印字: _____ HDF439 _____
PREPARED 编制: _____ CHECKED 审核: _____
APPROVED 批准: _____ D A T E 日期: _____ 2006-5-11 _____

客户确认 CUSTOMER RECEIVED:		
审核 CHECKED	批准 APPROVED	日期 DATE

无锡市好达电子有限公司
Shoulder Electronics Limited

1.Package

Ceramic package QCC8C

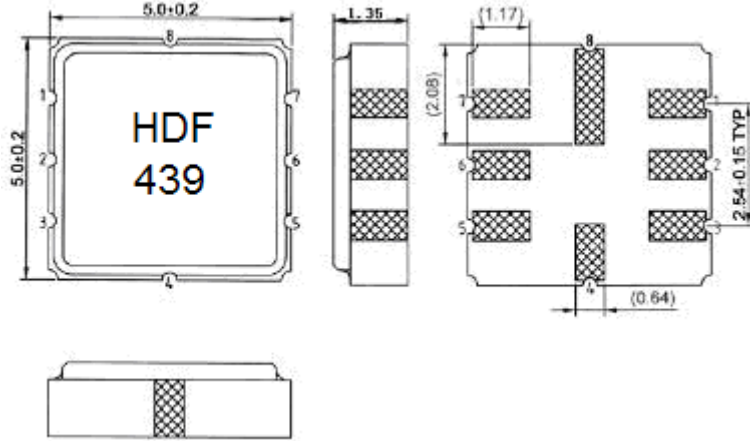

Marking: HDF439

HD: Brand

F : Filter

439 : No.

Dimensions in mm, appr. weight 0.1g

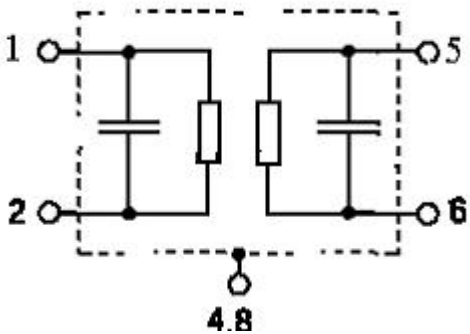

Pin configuration

- 1 Input
- 2 Input Ground
- 5 Output
- 6 Output Ground
- 4, 8 Case – Ground
- 3, 7 Ground

2. Performance

2.1 Absolute Maximum Ratings

Rating	Value	Units
Incident RF Power	+13	dBm
Case Temperature	-40 to +85	°C
DC Voltage Between Any Two Pins (Observe ESD Precautions)	±30	VDC

2.2 Electrical Characteristics

Reference temperature: $T_A = 25^\circ\text{C}$

Terminating source impedance: $Z_S = 50\ \Omega$ and matching network

Terminating load impedance: $Z_L = 50\ \Omega$ and matching network

Characteristic		Min.	Typ.		
Center Frequency f_c (center frequency between 3dB points)		--	433.96	--	MHz
Insertion Loss IL		--	3.0	5.5	dB
3dB Passband BW_3			± 300		kHz
3 dB Reject Band BW_3				± 500	kHz
Rejection	at $f_c-21.4\text{MHz}$ (Image)	40	50	--	dB
	at $f_c-10.7\text{MHz}$ (LO)	15	30	--	
	Ultimate	--	80	--	
Temperature	Operating Case Temperature T_c	-35		+85	$^\circ\text{C}$
	Turnover Temperature T_o	15	25	40	
	Turnover Frequency f_o		f_c		MHz
	Frequency Temperature Coefficient FTC		0.032		ppm/ $^\circ\text{C}$
Frequency Aging Year fA	Absolute Value during the First		10		ppm/yr

CAUTION: Electrostatic Sensitive Device. Observe precautions for handling!

3. Matching network to 50 Ω (element values depend on pcb layout and equivalent circuit)

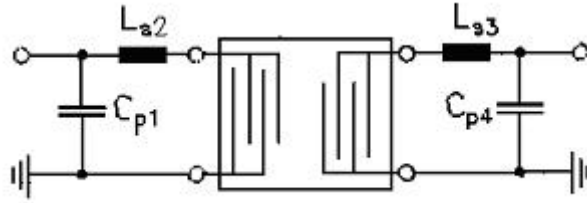

$C_{p1} = 10\text{pF}$, $L_{s2} = 43\text{nH}^*$, $L_{s3} = 43\text{nH}^*$, $C_{p4} = 10\text{pF}$

$L_{s2} = L_{s3} = 6$ turns of 0.51mm insulated Copper, 2.5mm ID.

4. Typical Frequency Response

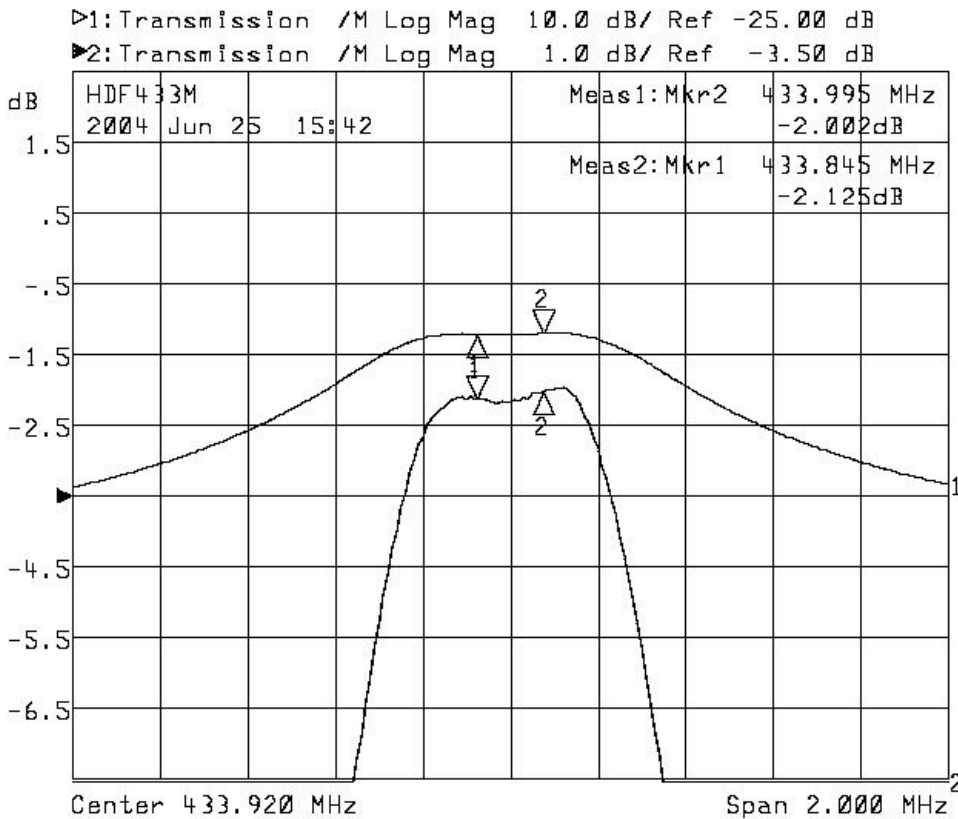

5. ENVIRONMENTAL CHARACTERISTICS

5-1 Temperature cycling

Subject the device to a low temperature of -40°C for 30 minutes. Following by a high temperature of $+25^{\circ}\text{C}$ for 5 Minutes and a higher temperature of $+85^{\circ}\text{C}$ for 30 Minutes. Then release the device into the room conditions for 1 to 2 hours prior to the measurement. It shall meet the specifications in 2.2.

5-2 Resistance to solder heat

Submerge the device terminals into the solder bath at $260^{\circ}\text{C} \pm 5^{\circ}\text{C}$ for 10 ± 1 sec. Then release the device into the room conditions for 4 hours. It shall meet the specifications in 2.2.

5-3 Solderability

Submerge the device terminals into the solder bath at $245^{\circ}\text{C} \pm 5^{\circ}\text{C}$ for 5s, More than 95% area of the soldering pad must be covered with new solder. It shall meet the specifications in 2.2.

5-4 Mechanical shock

Drop the device randomly onto the concrete floor from the height of 1 m 3 times. the filter shall fulfill the specifications in 2.2.

5-5 Vibration

Subject the device to the vibration for 2 hour each in x,y and z axes with the amplitude of 1.5 mm at 10 to 55 hz. The filter shall fulfill the specifications in 2.2.

6. REMARK

6.1 Static voltage

Static voltage between signal load & ground may cause deterioration & destruction of the component. Please avoid static voltage.

6.2 Ultrasonic cleaning

Ultrasonic vibration may cause deterioration & destruction of the component. Please avoid ultrasonic cleaning

6.3 Soldering

Only leads of component may be soldered. Please avoid soldering another part of component.

7. Packing

7.1 Dimensions

(1) Carrier Tape: Figure 1

(2) Reel: Figure 2

(3) The product shall be packed properly not to be damaged during transportation and storage.

7.2 Reeling Quantity

- 1000 pcs/reel 7"
- 3000 pcs/reel 13"

7.3 Taping Structure

(1) The tape shall be wound around the reel in the direction shown below.

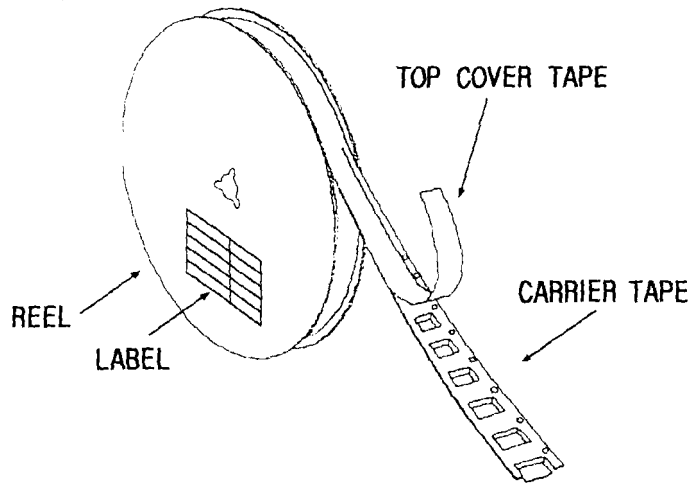

(2) Label

Device Name	
User Product Name	
Quantity	
Lot No.	

(3) Leader part and vacant position specifications.

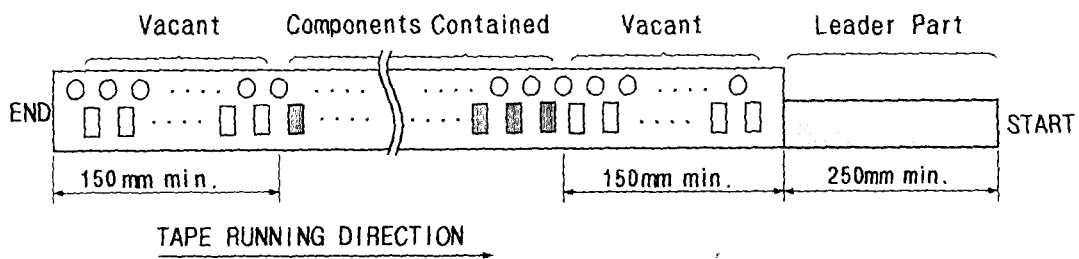

8. TAPE SPECIFICATIONS

8.1 Tensile Strength of Carrier Tape: 4.4N/mm width

8.2 Top Cover Tape Adhesion (See the below figure)

- (1) pull off angle: 0~15°
- (2) speed: 300mm/min.
- (3) force: 20~70g

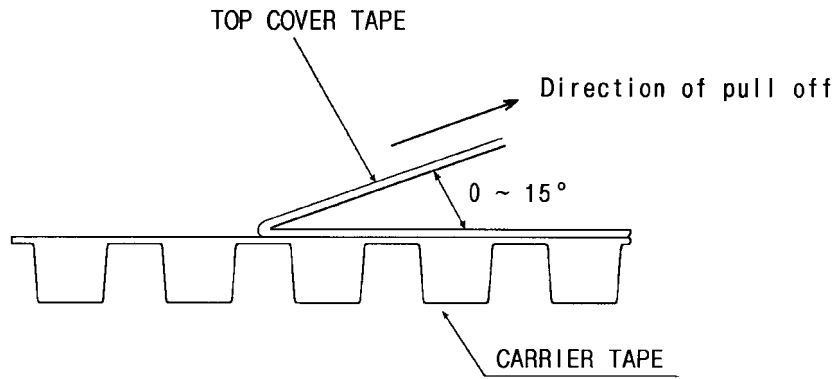

[Figure 1] Carrier Tape Dimensions

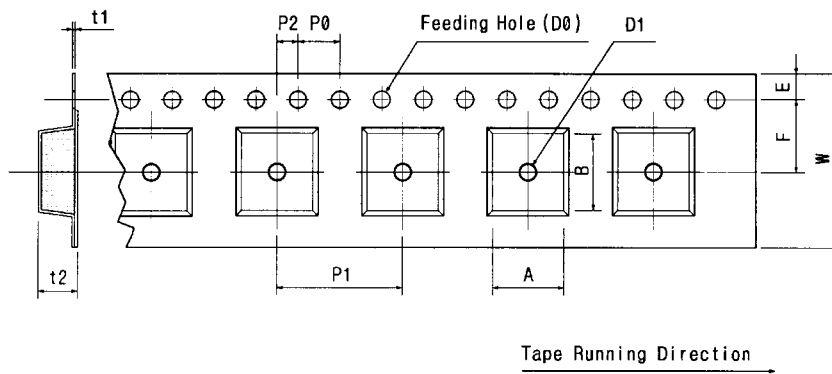

[Unit:mm]

W	F	E	P0	P1	P2	D0	D1	t1	t2	A	B
12.0	5.5	1.75	4.0	8.0	2.0	Ø1.5	Ø1.0	0.3	2.10	6.40	5.20
±0.3	±0.05	±0.1	±0.1	±0.1	±0.05	±0.1	±0.25	±0.05	±0.1	±0.1	±0.1

[Figure 2]

[Unit:mm]

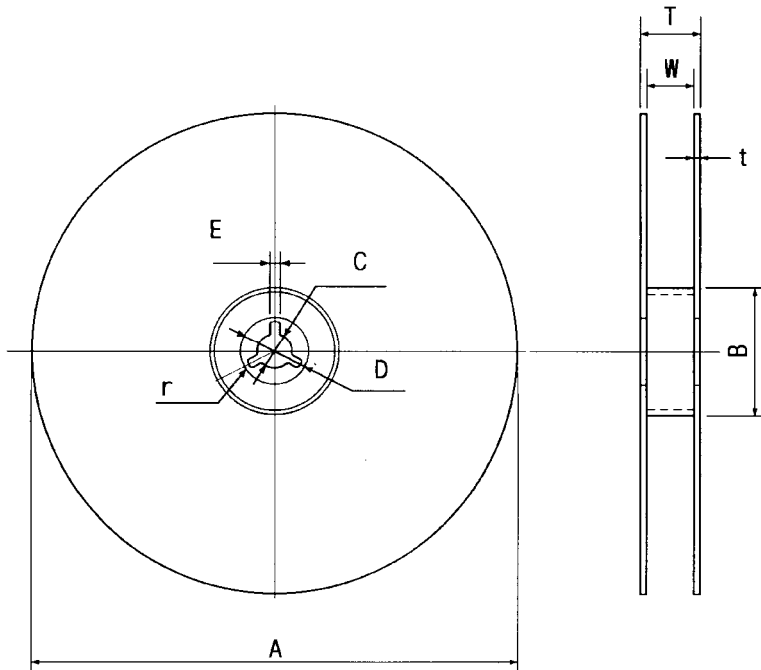

A	B	C	D	E	W	t	r
Ø330	Ø100	Ø13	Ø21	2	13	3	1.0
±1.0	±0.5	±0.5	±0.8	±0.5	±0.3	max.	max.