

AC High Performance Fans

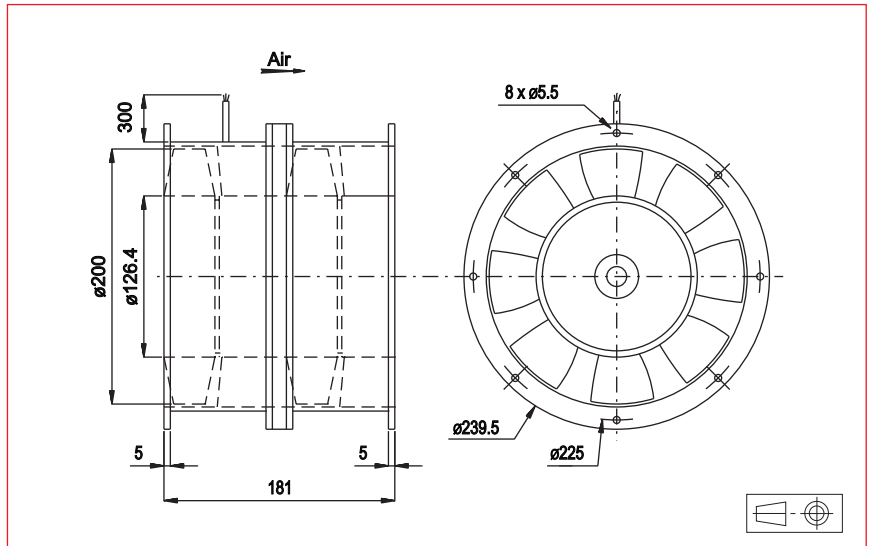

#### Approvals

CE, NATO codification

#### Life expectancy

L-10 LIFE AT 40°C:  
25 000 hours

#### AC Motor

Housing material: aluminium  
Impeller material: plastic  
Weight: 6,95 kg  
Bearing system: ball bearings

#### Available with:

- Safety switch
- Terminal block
- Aluminium impeller (62GR model)

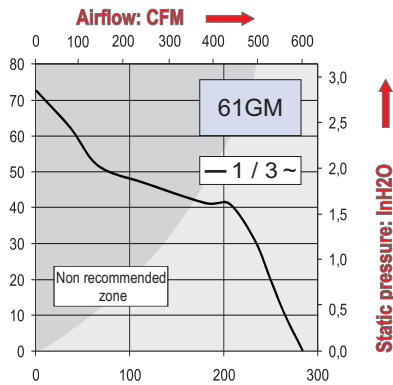
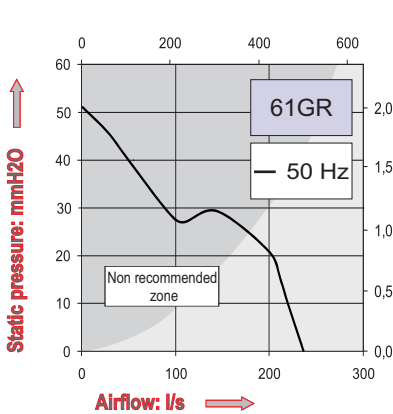

Part Number	Nominal voltage	Airflow	Noise level	Nominal speed	Frequency	Phases	Capacitor (not included)	Input power	Nominal Current	Starting Current	Connection type		Operating temperature	
	V	l/s	dB(A)	RPM	Hz		µF	W	mA	mA	Leads	Terminals	Min.°C	Max.°C
61GR116DC13A	230	235	75	2900	50	3		90	500	-	X		-10	70
	400	235	75	2900	50	3		90	290	-	X		-10	70
	230	235	75	2900	50	1	6,9	95	500	-	X		-10	70
	400	235	75	2900	50	1	2,2	95	490	-	X		-10	70
61GM116DC13A	230	283	80	3450	60	3		135	580	-	X		-10	70
	400	283	80	3450	60	3		135	350	-	X		-10	70
	230	283	80	3450	60	1	10	155	690	-	X		-10	70
	400	283	80	3450	60	1	3,2	155	390	-	X		-10	70

#### Additional versions:

Salt spray protected - Shock and vibration protected - Marine specifications  
Wide temperature range - Other voltages (consult factory)