



Thin-Film Cascadable Amplifier

5 to 500 MHz

Technical Data

UTO/UTC 512 Series

Features

- **Frequency Range: 5 to 500 MHz**
- **Medium Gain: 20.0 dB (Typ)**
- **Low Noise: 2.5 dB (Typ)**
- **Temperature Compensated**

Applications

- **IF/RF Amplification**

Description

The 512 Series is an efficient medium-gain thin-film bipolar RF amplifier. Resistive feedback and active bias provide temperature compensation and increased immunity to bias voltage variations. Blocking capacitors couple the RF through the amplifier. The 512 Series is available in either the TO-8 hermetic case or connected TC-1A package.

Pin Configuration

UTO—TO-8U

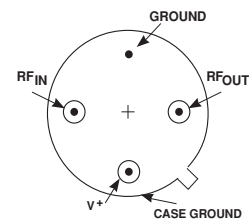

UTC—TC-1A

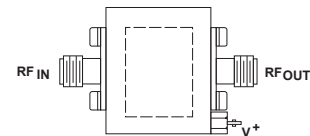

Schematic

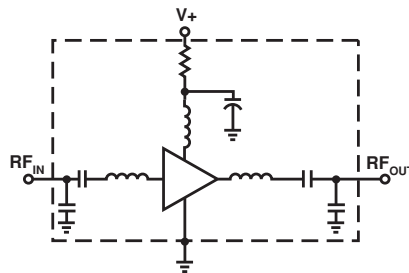

Maximum Ratings

Parameter	Maximum
DC Voltage	+17 Volts
Continuous RF Input Power	+13 dBm
Operating Case Temperature	-55 to +125°C
Storage Temperature	-62 to +150°C
"R" Series Burn-In Temperature	+125°C

Thermal Characteristics¹

θ_{JC}	105°C/W
Active Transistor Power Dissipation	190 mW
Junction Temperature Above Case Temperature	20°C
MTBF (MIL-HDBK-217E, A_{UF} @ 90°C)	684,000 Hrs.

Weight: (typical) UTO—2.1 grams; UTC—21.5 grams

Electrical Specifications

(Measured in 50 Ω system @ +15 VDC nominal unless otherwise noted)

Symbol	Characteristic	Typical $T_C = 25^\circ\text{C}$	Guaranteed Specifications		Unit
			$T_C = 0 \text{ to } 50^\circ\text{C}$	$T_C = -55 \text{ to } +85^\circ\text{C}$	
BW	Frequency Range	5-500	5-500	5-500	MHz
GP	Small Signal Gain (Min.)	21.0	20.0	19.0	dB
—	Gain Flatness (Max.)	± 0.5	± 1.0	± 1.0	dB
NF	Noise Figure (Max.)	2.5	3.0	3.0	dB
P _{1dB}	Power Output @ +1 dB Comp. (Min.)	+8.0	+7.0	+7.0	dBm
—	Input VSWR (Max.)	<1.5:1	<2.0:1	2.0:1	—
—	Output VSWR (Max.)	<1.3:1	<2.0:1	2.0:1	—
IP ₃	Two Tone 3rd Order Intercept Point	+20.0	—	—	dBm
IP ₂	Two Tone 2nd Order Intercept Point	+25.0	—	—	dBm
HP ₂	One Tone 2nd Harmonic Intercept Point	+31.0	—	—	dBm
I _D	DC Current	23	—	—	mA

Typical Performance Over Temperature (@ +15 VDC unless otherwise noted)

Key: +25°C —
+85°C - -
-55°C = =

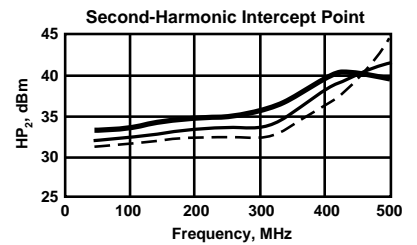
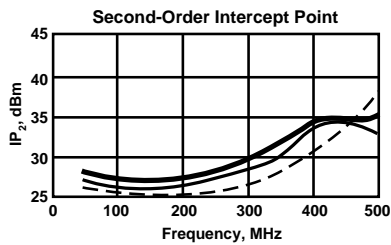
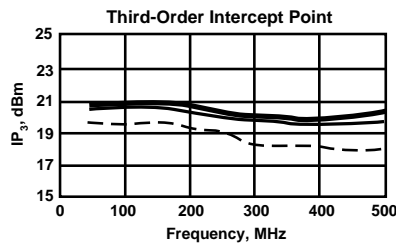
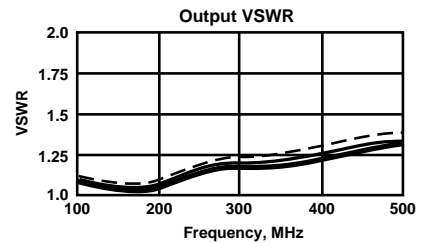
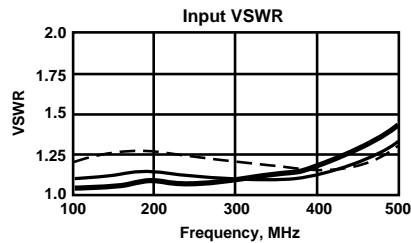
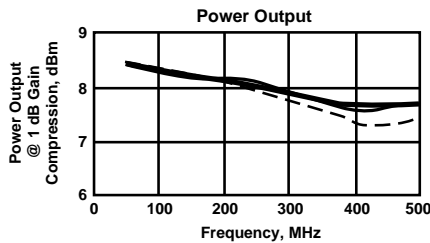
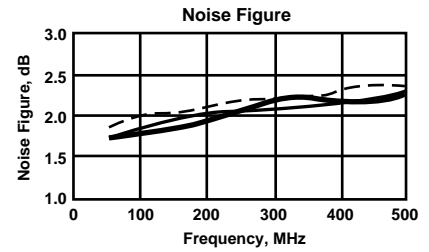
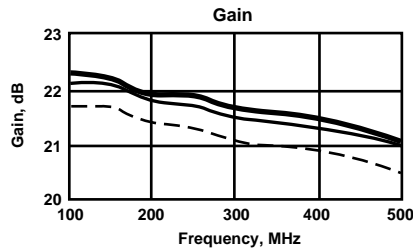

Automatic Network Analyzer Measurements (Typical production unit @ +25°C ambient)**Numerical Readings****Bias = 15.00 Volts**

FREQUENCY MHz	VSWR IN	GAIN dB	PHASE DEGREES	PHASE DEV	FLAT dB	GROUP DELAY ns	VSWR OUT	ISOLATION dB
100.0	1.43	21.18	142.44	-1.88	-.41	—	1.29	26.76
150.0	1.42	20.97	125.36	.03	-.21	.99	1.29	26.01
200.0	1.40	20.82	106.77	.44	-.06	1.06	1.27	26.79
250.0	1.39	20.78	87.38	.04	-.01	1.03	1.27	26.25
300.0	1.35	20.75	69.83	1.49	.00	1.03	1.27	26.20
350.0	1.30	20.67	50.31	.99	.09	1.06	1.28	26.21
400.0	1.25	20.59	31.56	1.24	.16	1.07	1.27	27.19
450.0	1.24	20.58	11.79	.48	.17	1.17	1.23	26.20
500.0	1.39	20.48	-10.56	-2.65	.27	1.23	1.24	26.85
550.0	1.74	20.24	-32.64	—	—	1.30	1.26	26.70
600.0	2.39	19.76	-57.33	—	—	1.35	1.32	27.94

LINEARIZATION RANGE: 100.0 to 500.0 MHz

S-Parameters**Bias = 15.00 Volts**

FREQUENCY MHz	S ₁₁		S ₂₁		S ₁₂		S ₂₂	
	Mag	Ang	dB	Ang	dB	Ang	Mag	Ang
100.00	.171	135.7	20.68	141.5	-26.74	-10.8	.085	179.3
200.00	.171	135.7	20.68	141.5	-26.74	-10.8	.065	179.3
300.00	.143	65.8	20.47	71.1	-26.56	-39.9	.122	146.8
400.00	.119	64.0	20.42	33.1	-26.74	-58.5	.131	116.1
500.00	.213	78.7	20.34	-9.1	-26.74	-82.4	.124	68.2
600.00	.454	55.5	19.66	-55.1	-27.96	-110.4	.133	-20.2
700.00	.722	19.3	17.51	-100.7	-31.37	-143.0	.251	-97.1
800.00	.851	-12.3	13.88	-142.8	-37.07	-172.2	.386	-145.3
900.00	.914	-38.6	10.10	-178.5	-46.00	166.1	.493	-179.0
1000.00	.928	-58.5	6.28	153.9	-60.00	4.9	.559	157.0

Product Options

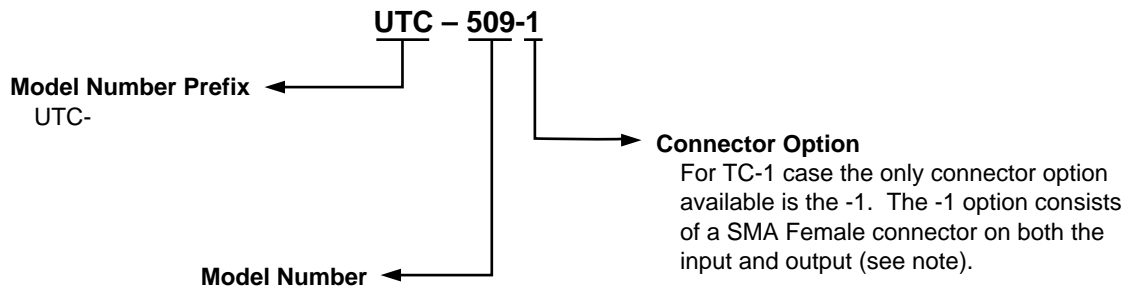
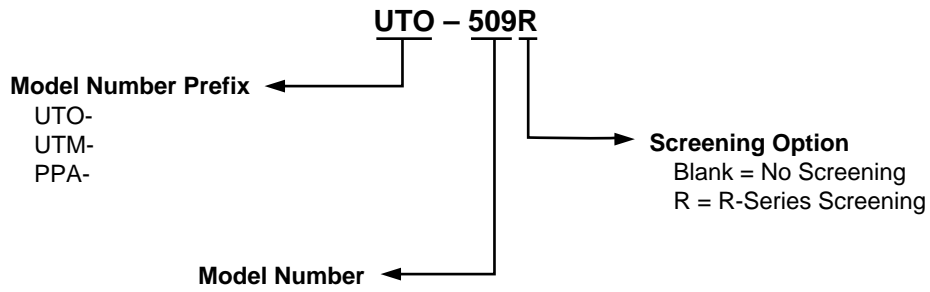

Note: R-Series screening is not available in the TC-1 case as the case is non-hermetic.

**Case Drawings
TO-8U**

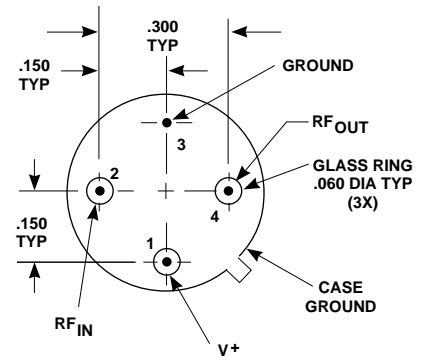
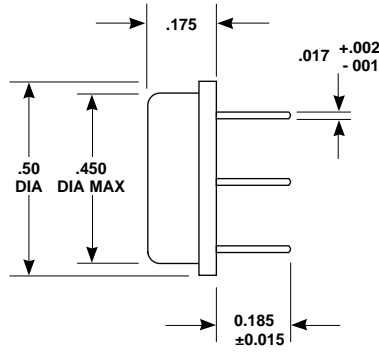
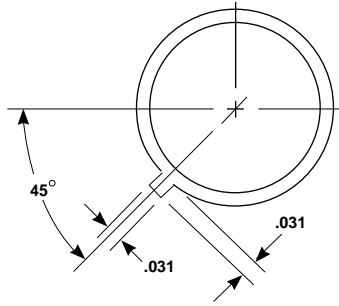

APPROXIMATE WEIGHT 2.1 GRAMS

- NOTES (UNLESS OTHERWISE SPECIFIED):**
 1. DIMENSIONS ARE SPECIFIED IN INCHES
 2. TOLERANCES: xx ± .02
 xxx ± .010

TC-1A

