

48 V Input	9.6 V Output	84 A Current	764.4 W Power	2000 V dc Isolation	Quarter-brick DC-DC Converter
----------------------	------------------------	------------------------	-------------------------	-------------------------------	---

The BusQor BQ57090QZB84 bus converter is a next-generation, board-mountable, isolated, fixed switching frequency DC/DC converter that uses synchronous rectification to achieve extremely high conversion efficiency. The power dissipated by the converter is so low that a heatsink is not required, which saves cost, weight, height, and application effort. The BusQor series provides an isolated step down voltage from 48 V to 9.6 V intermediate bus with no regulation in a standard quarter-brick module. BusQor converters are ideal for creating the mid-bus voltage required to drive point-of-load (non-isolated) converters in intermediate bus architectures.

BusQor®



BQ57090QZB84 Model

Operational Features

- High efficiency, 96.7% at full rated load current
- Delivers 84 A full power with minimal derating
- Operating input voltage range: 40-65 V
- Fixed frequency switching provides predictable EMI
- No minimum load requirement

Control Features

- On/Off control referenced to input side (only negative logic options is available)
- Inherent current share (by droop method) for high current and parallel applications.

Safety Features

- UL 60950-1/R2011-12
- EN60950-1/A2:2013
- CAN/CSA-C22.2 No. 60950-1/A1:2011

Mechanical Features

- Industry standard quarter-brick pin-out configuration
- Size: 1.51"x 2.34" (38.4 x 59.4mm), height: 0.517" (13.13mm)
- Total Baseplate weight: 2.67 oz (75.7 g)

Protection Features

- Input under-voltage lockout and over-voltage shutdown protects against abnormal input voltages
- Output current limit and short circuit protection (auto recovery)
- Output over-voltage protection
- Thermal shutdown

Contents

	Page No.
Baseplated Mechanical Diagram	2
Electrical Characteristics	3
Compliance & Testing	5
Technical Figures	6
Applications Section	9
Ordering Information	13

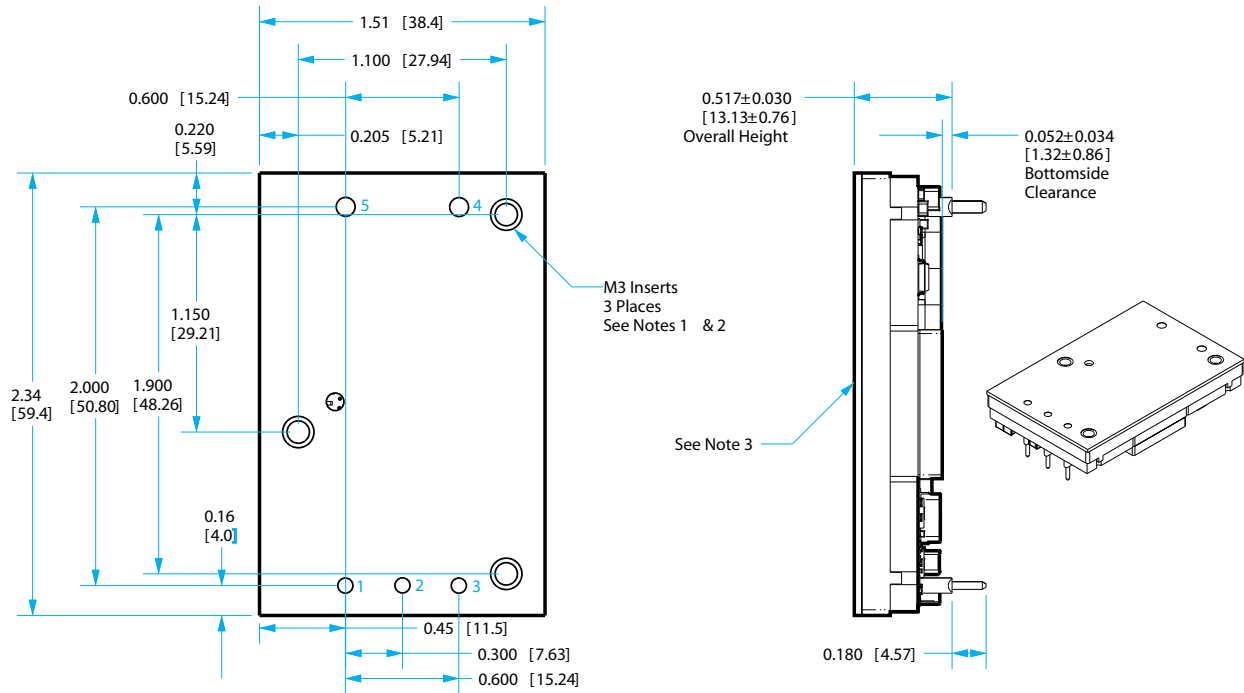

NOTES

- 1) M3 screws used to bolt unit's baseplate to other surfaces such as heatsinks must not exceed 0.10" (2.54mm) depth below the surface of the baseplate.
- 2) Applied torque per screw should not exceed 6in-lb (0.7nm)
- 3) Baseplate flatness tolerance is 0.004" (.10mm) TIR for surface
- 4) Other pin extension lengths available
- 5) Pins 1-3 are 0.040" (1.02mm) dia. with 0.080" (2.03mm) dia. standoff shoulders
- 6) Pins 4 and 5 are 0.062" (1.57mm) dia. with 0.100" (2.54mm) dia. standoff shoulders
- 7) All pins: Material: Copper Alloy
Finish: Matte Tin over Nickel plate
- 8) Undimensioned components are shown for visual reference only
- 9) Baseplate weight: 2.67 oz (75.7 g) typical
- 10) All dimensions in inches(mm)
Tolerances: x.xx in +/-0.02 (x.xmm +/-0.5mm)
x.xxx in +/-0.010 (x.xxmm +/-0.25mm)

PIN DESIGNATIONS

Pin	Name	Function
1	Vin(+)	Positive input voltage
2	ON/OFF	Logic control input to turn converter on/off.
3	Vin(-)	Negative input
4	Vout(-)	Negative output
5	Vout(+)	Positive output



Technical Specification

Input: 40-65 V
Output: 9.6 V
Current: 84A
Package: Quarter-brick

BQ57090QZB84 Electrical Characteristics

Ta = 25 °C, airflow rate = 300 LFM, Vin = 48 V dc unless otherwise noted; full operating temperature range is -40 °C to +100 °C baseplate temperature with appropriate power derating. Specifications subject to change without notice.

Parameter	Min.	Typ.	Max.	Units	Notes & Conditions
ABSOLUTE MAXIMUM RATINGS					
Input Voltage					
Non-Operating	-0.5		75	V	Continuous
Operating	40		65	V	Continuous
Isolation Voltage					
Input to Output			2000	V	
Operating Temperature	-40		100	°C	
Storage Temperature	-45		125	°C	
Voltage at ON/OFF input pin	-2		18	V	
INPUT CHARACTERISTICS					
Operating Input Voltage Range	40	48	65	V	
Input Under-Voltage Lockout					
Turn-On Voltage Threshold		38.4		V	
Turn-Off Voltage Threshold		35.8		V	
Lockout Voltage Hysteresis		2.6		V	
Input Over-Voltage Shutdown				V	
Turn-On Voltage Threshold		66.3		V	
Turn-Off Voltage Threshold		68.5		V	
Maximum Input Current			16.8	A	
No-Load Input Current			145	mA	
Disabled Input Current		16.0	26.0	mA	
Input Reflected-Ripple Current		25	40	mA	RMS through 10 µH inductor
Input Terminal-Ripple Current		350		mA	RMS, full load
Recommended Input Fuse (see Note 1)			30	A	Fast blow external fuse recommended
Recommended External Input Capacitance		47		µF	Typical ESR 0.1-0.2 Ω
Input Filter Component Values (L\C)		0.22\30		µH\µF	Internal values
OUTPUT CHARACTERISTICS					
Output Voltage Set Point		9.5		V	Io = 0 A
Output Voltage Regulation					
Over Line		47\5.0		%\V	
Over Load		6.25\600		%\mV	
Over Temperature		2.1\200		%\mV	
Total Output Voltage Range	7.200		13.000	V	Over sample, line, load, temperature & life
Output Voltage Ripple and Noise					20 MHz bandwidth; see Note 2
Peak-to-Peak		150	250	mV	Full load
RMS		50		mV	Full load
Operating Output Current Range	0		84	A	Subject to thermal derating
Output DC Current-Limit Inception		92		A	Output Voltage 10% Low
Output DC Current-Limit Shutdown Voltage		6.5		V	
Back-Drive Current Limit while Disabled		10		mA	Negative current drawn from output
Maximum Output Capacitance			5,000	µF	9.6 Vout at 42 A Resistive Load
EFFICIENCY					
100% Load		96.7		%	
50% Load		97.5		%	



Technical Specification

Input: 40-65 V
Output: 9.6 V
Current: 84A
Package: Quarter-brick

BQ57090QZB84 Electrical Characteristics (continued)

Ta = 25 °C, airflow rate = 300 LFM, Vin = 48 V dc unless otherwise noted; full operating temperature range is -40 °C to +100 °C baseplate temperature with appropriate power derating. Specifications subject to change without notice.

Parameter	Min.	Typ.	Max.	Units	Notes & Conditions
DYNAMIC CHARACTERISTICS					
Output Voltage during Load Current Transient					
Step Change in Output Current (0.1 A/μs)		150		mV	50% to 75% to 50% Iout max
Settling Time		100		μs	To within 1% Vout nom
Turn-On Transient					
Turn-On Time (with 5 mF output capacitance)		5	10	ms	42 A Resistive, Vout=90% nom.
Start-Up Inhibit Time		800		ms	-40 °C to +125 °C; Figure E
Output Voltage Overshoot		2		%	5 mF load capacitance
ISOLATION CHARACTERISTICS					
Isolation Voltage (dielectric strength)		2000		V	See Absolute Maximum Ratings
Isolation Resistance		30		MΩ	
Isolation Capacitance (input to output)		1000		pF	See Note 3
Semiconductor Junction Temperature			125	°C	Package rated to 150 °C
Board Temperature			125	°C	UL rated max operating temp 130 °C
Transformer Core Temperature			130	°C	
Maximum Baseplate Temperature, Tb			100	°C	
FEATURE CHARACTERISTICS					
Switching Frequency	140	165	190	kHz	
ON/OFF Control (Option N)					
On-State Voltage	-1		0.8	V	
Off-State Voltage	2.4		18	V	
ON/OFF Control (Either Option)					Application notes Figures A & B
Pull-Up Voltage		3.3		V	
Pull-Up Resistance		100		kΩ	
Over-Temperature Shutdown OTP Trip Point	140		150	°C	Average PCB Temperature
Over-Temperature Shutdown Restart Hysteresis		10		°C	
RELIABILITY CHARACTERISTICS					
Calculated MTBF (Telcordia) TR-NWT-000332		4.8		10 ⁶ Hrs.	80% load, 200 LFM, 40 °C Ta
Calculated MTBF (MIL-217) MIL-HDBK-217F		3.3		10 ⁶ Hrs.	80% load, 200 LFM, 40 °C Ta
Field Demonstrated MTBF				10 ⁶ Hrs.	See our website for details

Note 1: UL's product certification tests were carried out using 30 A fast blow fuse. Fuse interruption characteristics have to be taken into account while designing input traces. User should ensure that Input trace is capable of withstanding fault currents

Note 2: For applications requiring reduced output voltage ripple and noise, consult SynQor applications support (e-mail: support@synqor.com)

Note 3: Isolation capacitance can be added external to the module.



Technical Specification

Input: 40-65 V
Output: 9.6 V
Current: 84A
Package: Quarter-brick

Compliance & Testing

Parameter	Notes & Conditions
-----------	--------------------

STANDARDS COMPLIANCE

UL 60950-1/R2011-12	Basic insulation
EN60950-1/A2:2013	
CAN/CSA-C22.2 No. 60950-1/A1:2011	

Note: An external input fuse must always be used to meet these safety requirements. Contact SynQor for official safety certificates on new releases or download from the SynQor website.

Parameter	# Units	Test Conditions
-----------	---------	-----------------

QUALIFICATION TESTING

Life Test	32	95% rated V_{in} and load, units at derating point, 1000 hours
Vibration	5	10-55 Hz sweep, 0.060" total excursion, 1 min./sweep, 120 sweeps for 3 axis
Mechanical Shock	5	100g minimum, 2 drops in x, y and z axis
Temperature Cycling	10	-40 °C to 100 °C, unit temp. ramp 15 °C/min., 500 cycles
Power/Thermal Cycling	5	Toperating = min to max, V_{in} = min to max, full load, 100 cycles
Design Marginality	5	Tmin-10 °C to Tmax+10 °C, 5 °C steps, V_{in} = min to max, 0-105% load
Humidity	5	85 °C, 95% RH, 1000 hours, continuous V_{in} applied except 5 min/day
Solderability	15 pins	MIL-STD-883, method 2003

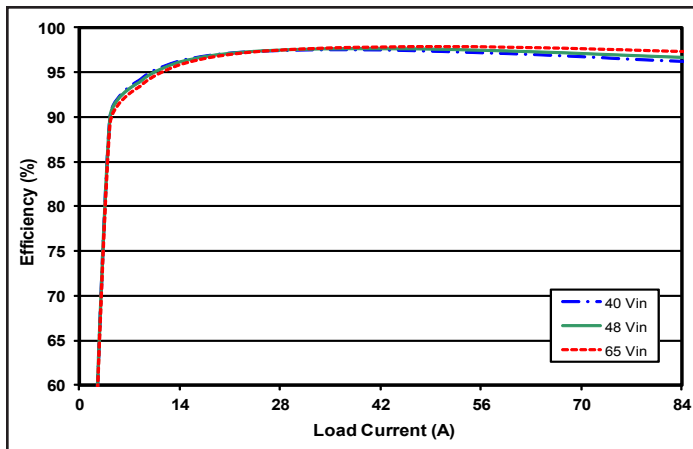

Figure 1: Efficiency at nominal output voltage vs. load current for minimum, nominal, and maximum input voltage at 25 °C.

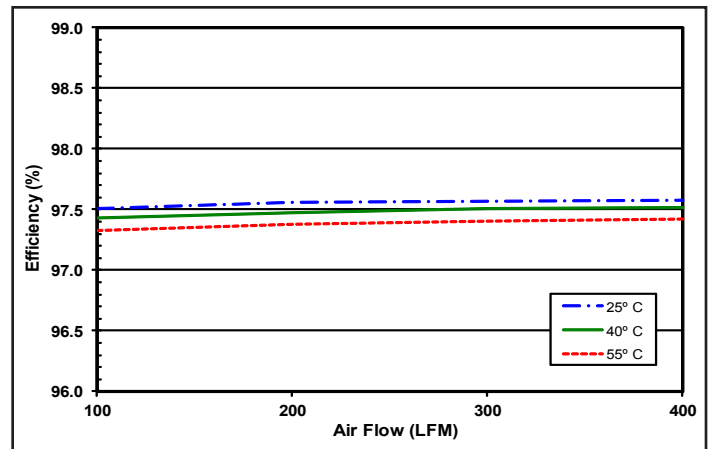

Figure 2: Efficiency at nominal output voltage and 60% rated power vs. airflow rate for ambient air temperatures of 25 °C, 40 °C, and 55 °C (nominal input voltage).

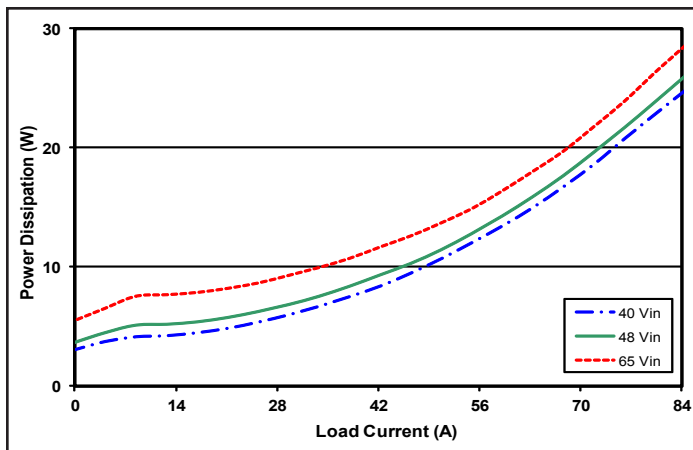

Figure 3: Power dissipation at nominal output voltage vs. load current for minimum, nominal, and maximum input voltage at 25 °C.

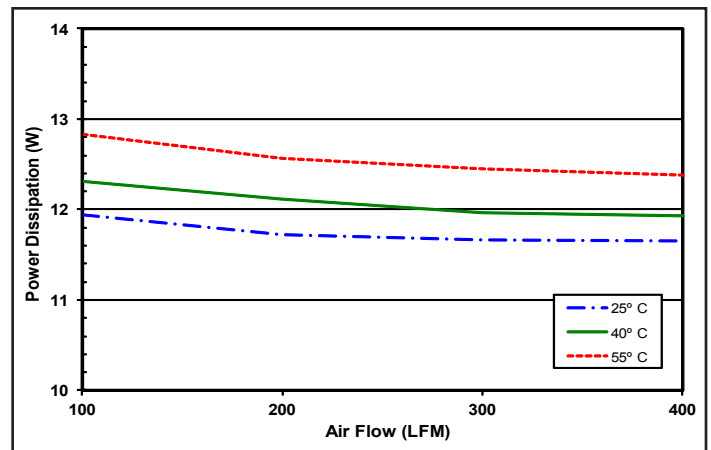

Figure 4: Power dissipation at nominal output voltage and 60% rated power vs. airflow rate for ambient air temperatures of 25 °C, 40 °C, and 55 °C (nominal input voltage).

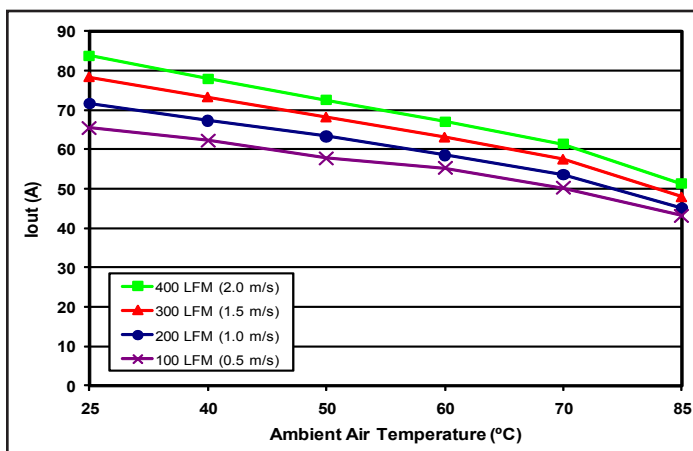

Figure 5: Maximum output power-derating curve vs. ambient air temperature for airflow rates of 100 LFM through 400 LFM with air flowing from pin 1 to pin 3 (nominal input voltage).

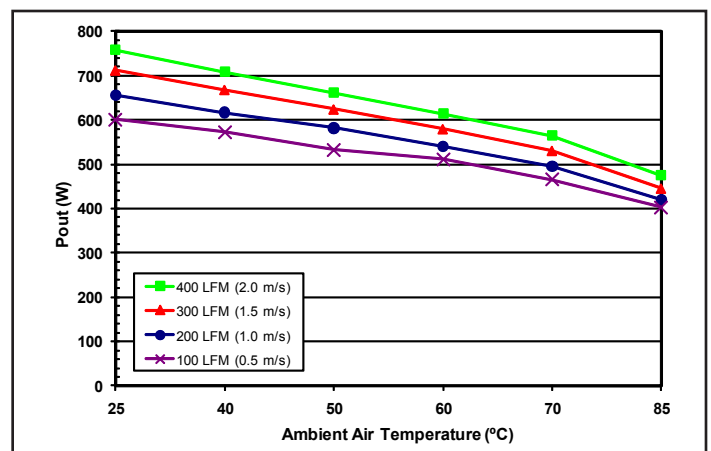

Figure 6: Thermal plot of converter at 41.4 A load current (420 W) with 55 °C air flowing at the rate of 200 LFM. Air is flowing across the converter from pin 1 to pin 3 (nominal input voltage).

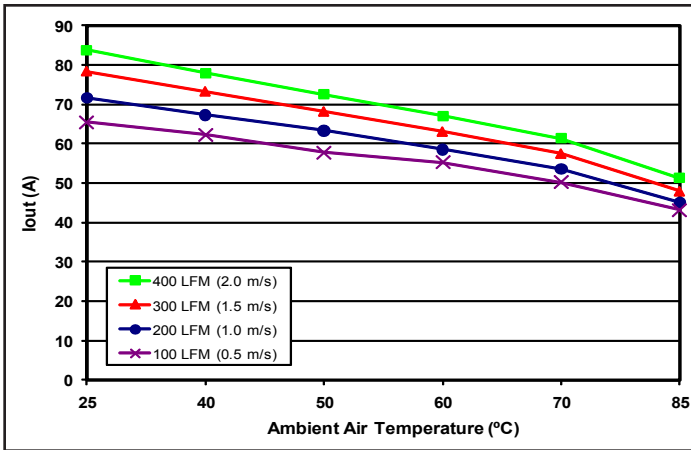

Figure 7: Max output power derating curves vs. ambient air temperature for airflow rates of 100 LFM through 400 LFM with air flowing across the converter from output to input (nominal input voltage).

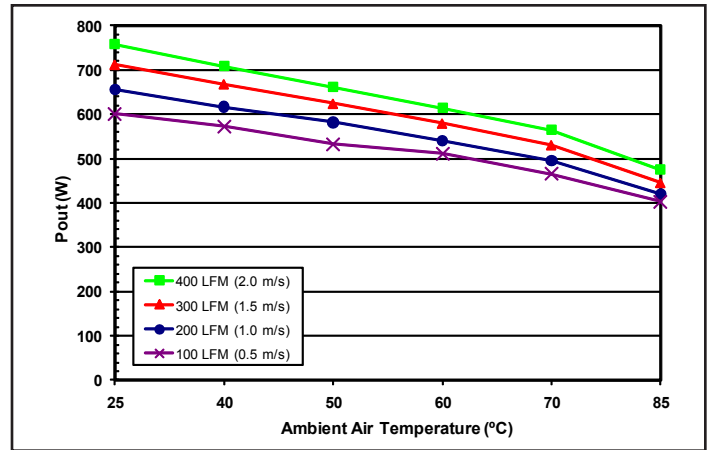

Figure 8: Thermal plot of converter at 38.3 A load current (389 W) with 55 °C air flowing at the rate of 200 LFM. Air is flowing across the converter from output to input (nominal input voltage).

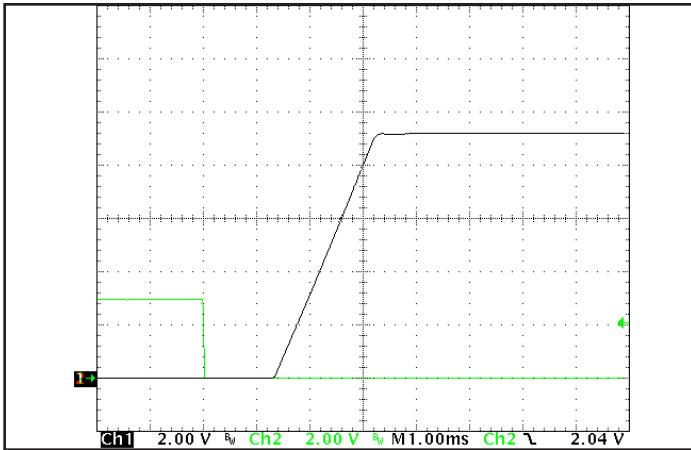

Figure 9: Turn-on transient at 50% load (resistive load) (5 ms/div). Load cap: 5 mF output capacitance. Input voltage pre-applied. Ch 1: V_{out} (2 V/div), Ch 2: ON/OFF input (2 V/div).

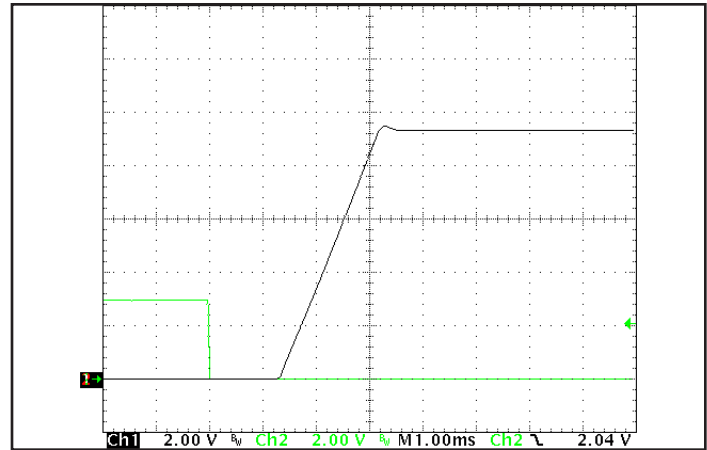

Figure 10: Turn-on transient at zero load (5 ms/div). Load cap: 5 mF output capacitance. Ch 1: V_{out} (2 V/div), Ch 2: ON/OFF input (2 V/div).

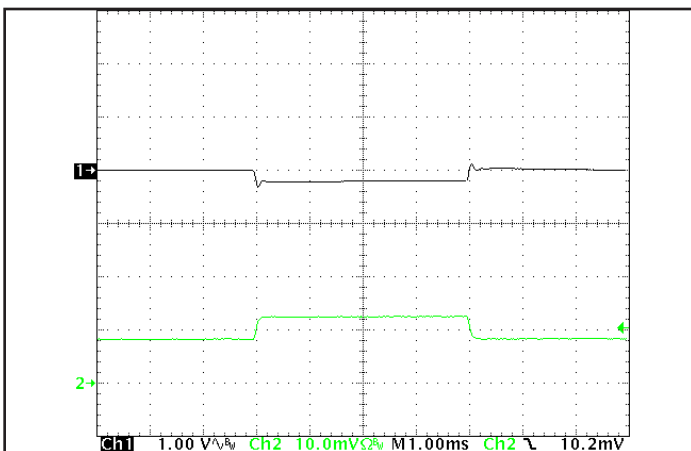

Figure 11: Output voltage response to step-change in load current (50%-75%-50% of $I_{out(max)}$; $dI/dt = 0.1 A/\mu s$). Load cap: 15 μF tantalum cap and 1 μF ceramic cap. Ch 1: V_{out} (1 V/div), Ch 2: I_{out} (50 A/div).

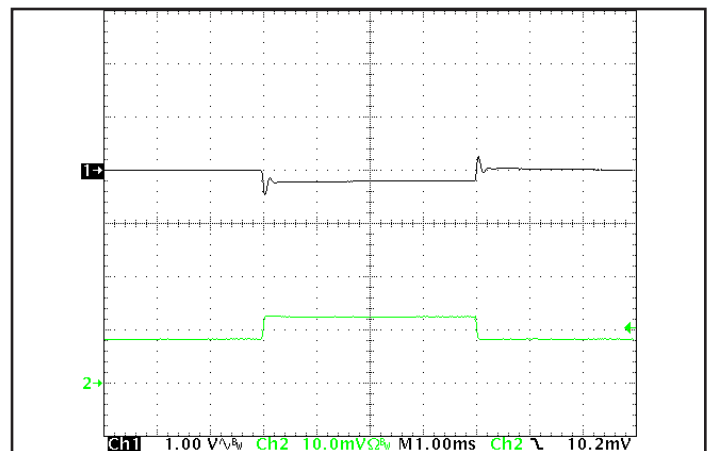

Figure 12: Output voltage response to step-change in load current (50%-75%-50% of $I_{out(max)}$; $dI/dt = 1 A/\mu s$). Load cap: 15 μF , 30 m Ω ESR tantalum cap and 1 μF ceramic cap. Ch 1: V_{out} (1 V/div), Ch 2: I_{out} (50 A/div).

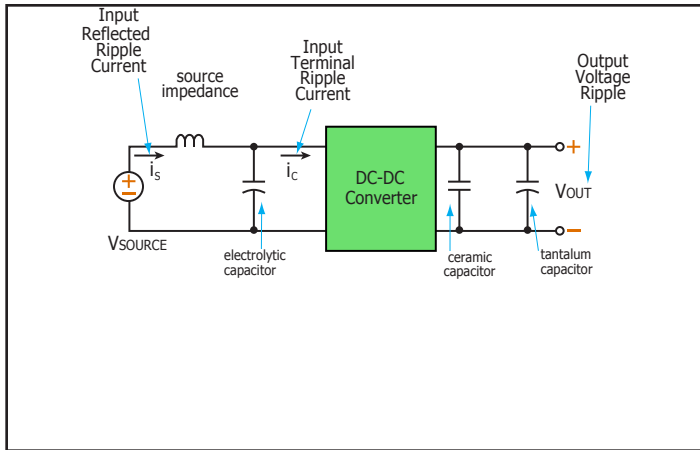

Figure 13: Test set-up diagram showing measurement points for Input Terminal Ripple Current (Figure 14), Input Reflected Ripple Current (Figure 15) and Output Voltage Ripple (Figure 16).

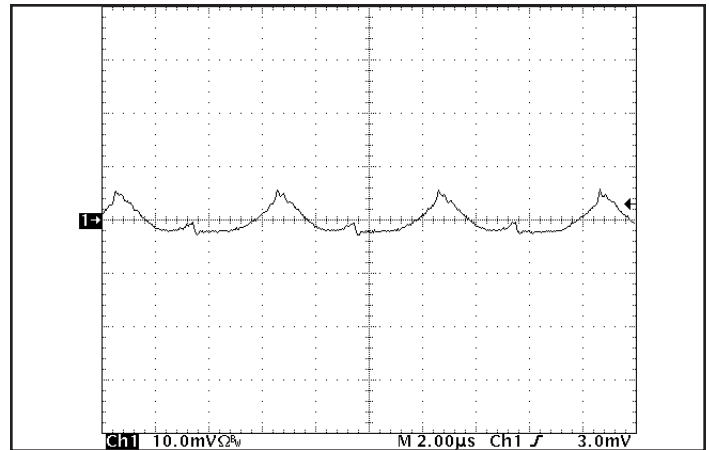

Figure 14: Input Terminal Ripple Current, i_c , at full rated output current and nominal input voltage with 10 μ H source impedance and 47 μ F electrolytic capacitor (1 A/div). See Figure 13.

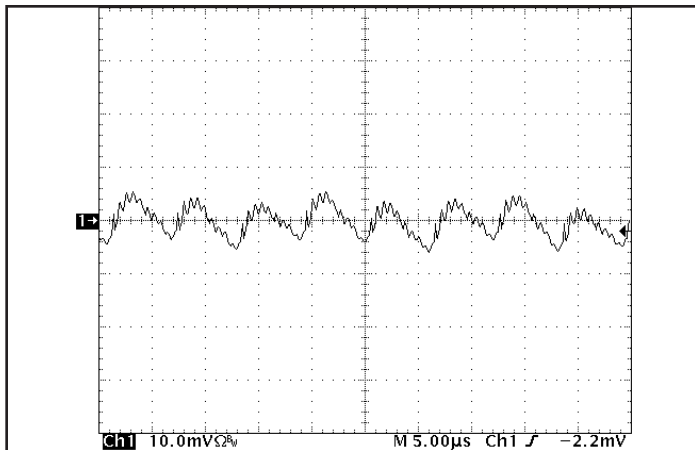

Figure 15: Input reflected ripple current, i_s , through a 10 μ H source inductor, using a 47 μ F electrolytic input capacitor (20 mA/div). See Figure 13.

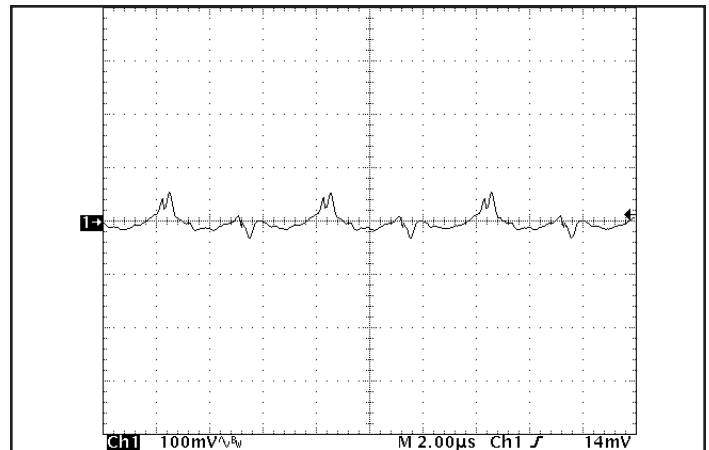

Figure 16: Output voltage ripple at nominal input voltage and rated load current (100 mV/div). Load capacitance: 1 μ F ceramic capacitor and 15 μ F tantalum capacitor. Bandwidth: 20 MHz. See Figure 13.

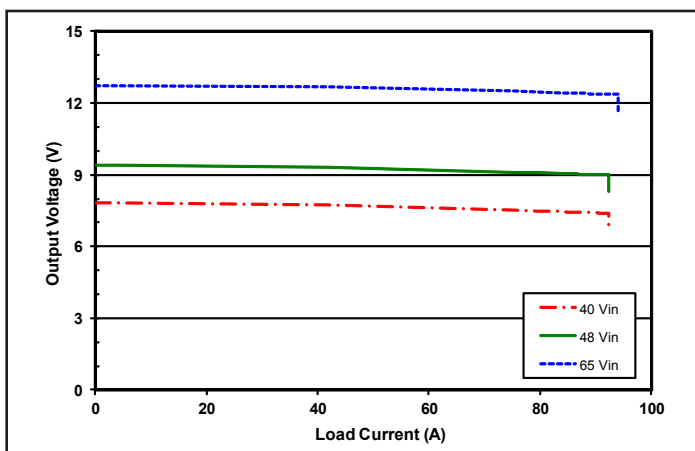

Figure 17: Output voltage vs. load current for different input voltages showing typical current limit curves.

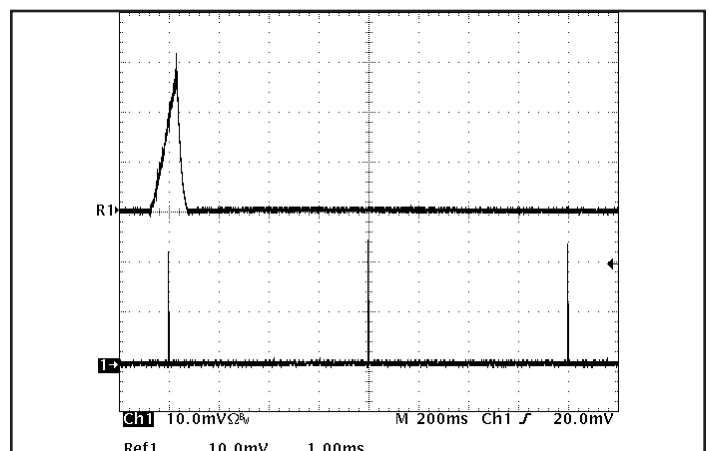

Figure 18: Load current (50 A/div) as a function of time when the converter attempts to turn on into a 1 $\text{m}\Omega$ short circuit. Top trace (1 ms/div) is an expansion of the on-time portion of the bottom trace.

BASIC OPERATION AND FEATURES

With voltages dropping and currents rising, the economics of an Intermediate Bus Architecture (IBA) are becoming more attractive, especially in systems requiring multiple low voltages. IBA systems separate the role of isolation and voltage scaling from regulation and sensing. The BusQor series bus converter provides isolation and an unregulated voltage step down in one compact module, leaving regulation to simpler, less expensive non-isolated converters.

In Figure A below, the BusQor module provides the isolation stage of the IBA system. The isolated bus then distributes power to the non-isolated buck regulators to generate the required voltage levels at the points of load. In this case, the bucks are represented with SynQor's NiQor series of non-isolated DC/DC converters. In many applications requiring multiple low voltage outputs, significant savings can be achieved in board space and overall system costs

When designing an IBA system with bus converters, the designer can select from a variety of bus voltages. While there is no universally ideal bus voltage, most designs employ one of the following: 12V, 9.6V, 7.5V, 5V, or 3.3V. Higher bus voltages can lead to lower efficiency for the buck regulators but are more efficient for the bus converter and provide lower board level distribution current. Lower bus voltages offer the opposite trade offs.

SynQor's BusQor modules act as a true dc transformer. The output voltage is proportional to the input voltage, with a specified "turns ratio" or voltage ratio, plus minor drop from the internal resistive losses in the module. When used in IBA systems, the output variation of the BusQor must be in accordance with the input voltage range of the non-isolated converters being employed.

The BusQor architecture is very scalable, meaning multiple bus converters can be connected directly in parallel to allow current sharing for higher power applications.

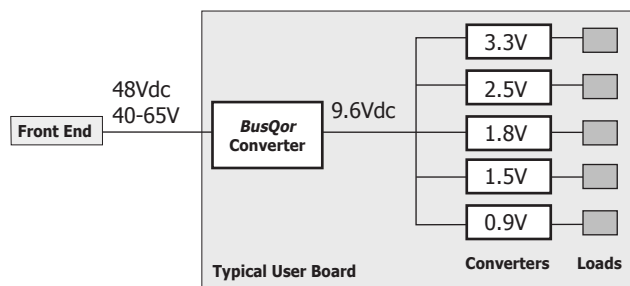

Figure A: Example of Intermediate Bus Architecture using BusQor bus converter and NiQor non-isolated converters

CONTROL FEATURES

REMOTE ON/OFF (Pin 2): The ON/OFF input, Pin 2, permits the user to control when the converter is on or off. This input is referenced to the return terminal of the input bus, Vin(-).

In the negative logic version, the ON/OFF signal is active low (meaning that a low turns the converter on). Figure B is a detailed look of the internal ON/OFF circuitry.

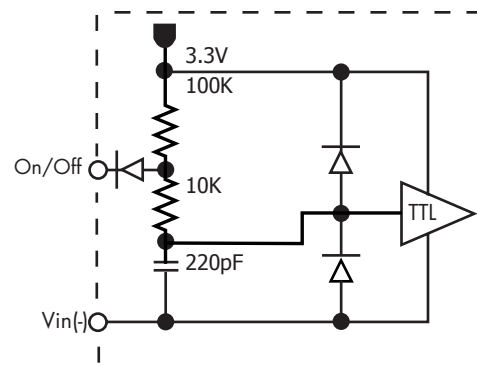

Figure B: Internal ON/OFF pin circuitry

PROTECTION FEATURES

Input Under-Voltage Lockout: The converter is designed to turn off when the input voltage is too low, helping avoid an input system instability problem, described in more detail in the application note titled "Input System Instability". The lockout circuitry is a comparator with DC hysteresis. When the input voltage is rising, it must exceed the typical Turn-On Voltage Threshold value (listed on the specification page) before the converter will turn on. Once the converter is on, the input voltage must fall below the typical Turn-Off Voltage Threshold value before the converter will turn off. Also see Figure E.

Output Current Limit: The output of the BusQor module is electronically protected against output overloads. When an overload current greater than the "DC Current-Limit Inception" specification is drawn from the output, the output shuts down to zero volt in a period of 1ms typical (see Figure C). The shutdown period lasts for a typical period of 800ms (Figure D) after which the BusQor tries to power up again (10ms). If the overload persists, the output voltage will go through repeated cycles of shutdown and restart with a duty cycle of 1.25% (On) and 98.75% (Off) respectively. The BusQor module returns (auto resetting) to normal operation once the overload is removed. The BusQor is designed to survive in this mode indefinitely without damage and without human intervention.

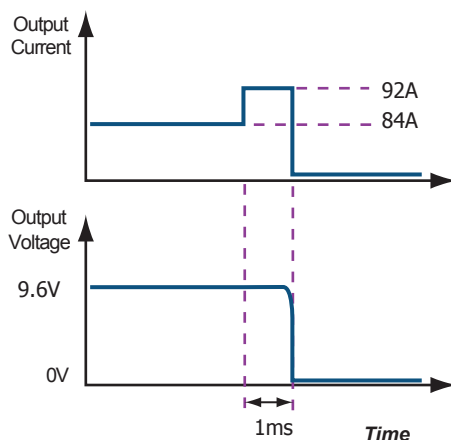

Figure C: Output Overload protection diagram (not to scale)

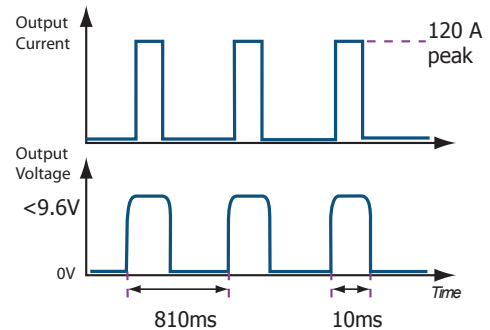

Figure D: Output Short Circuit and Auto-Resetting protection diagram (not to scale)

Output Short Circuit Protection: When the output of the BusQor module is shorted, a peak current of typically 100 A will flow into the short circuit for a period of about 1ms. The output of the BusQor will shutdown to zero for ~ 800mS (Figure D). At the end of the shutdown period the BusQor module tries to power up again. If the short circuit persists, the output voltage will go through repeated cycles of shutdown and restart with a duty cycle of 1.25% (On) and 98.75% (Off) respectively. The BusQor module returns (auto resetting) to normal operation once the short circuit is removed. The BusQor is designed to survive in this mode indefinitely without damage and without human intervention.

In the Auto resetting mode, also referred to as "Hiccup" mode, the power drawn from the 48V input is about 3 Watts, most of which is dissipated into the external fault. It is important that copper traces and pads from the output circuit be designed to withstand the short term peaks, although the average current into the fault may be as low as 0.1A typical. See Figure 18 for appropriate waveform.

Over-Temperature Shutdown: A temperature sensor on the converter senses the average temperature of the module. The thermal shutdown circuit is designed to turn the converter off when the temperature at the sensed location reaches the Over-Temperature Shutdown value. It will allow the converter to turn on again when the temperature of the sensed location falls by the amount of the Over-Temperature Shutdown Restart Hysteresis value.

APPLICATION CONSIDERATIONS

Start-Up Inhibit Period: Figure E details the Start-Up Inhibit Period for the BusQor module. At time t_0 , when V_{in} is applied with On/Off pin asserted (enabled), the BusQor output begins to build up. Before time t_1 , when the input voltage is below the UVL threshold, the unit is disabled by the Input Under-Voltage Lockout feature. When the input voltage rises above the UVL threshold, the Input Under-Voltage Lockout is released, and a typical Startup Inhibit Period of 12ms is initiated. The output builds up to 90% of the nominal value of 9.6V in a period of 5ms typical (50 % load).

At time t_2 , when the On/Off pin is de-asserted (disabled), the BusQor output instantly drops to 0V. Fall time from 9.6V to 0V is dependent on output capacitance and any parasitic trace inductance in the output load circuit.

At time t_3 , when the On/Off pin is re-asserted (enabled), the BusQor module output begins to build up after the inhibit period of 800 ms typical has elapsed.

Refer to the Control Features section of the data sheet for details on enabling and disabling methods for Bus Qor modules.

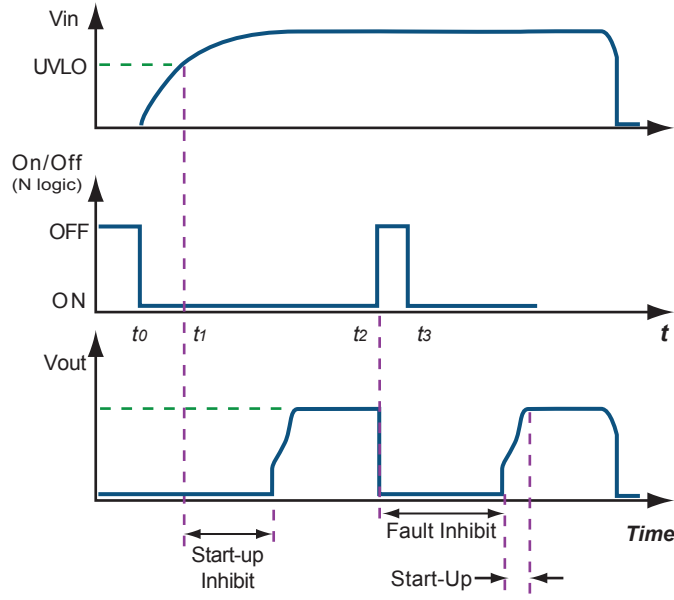

Figure E: Power Up/Down Diagram (not to scale) showing Start-Up Inhibit Period

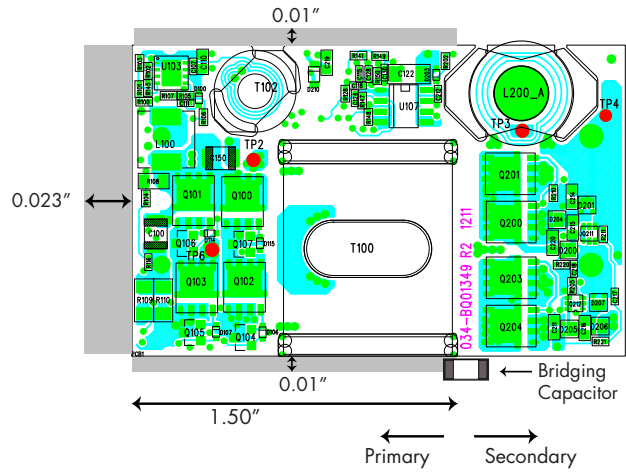

Figure F: Keep Out Areas for BusQor module (view from bottom)

Component Keep Out Area: Keep out areas for components not referenced to the Primary circuit are shown in shaded areas in Figure F. The keep out areas are consistent with UL's requirements for Basic Insulation of 0.04" (40 mils) for Pollution degree 2. User should consult UL standards for other insulation classes and operating environments.

For applications that require mounting parts BELOW the BusQor module, one should be aware of potential high levels of electromagnetic interference, in addition to safety keep out. Users are advised to consult SynQor Applications engineering in such applications.

Copper Keep Out Area: Keep out areas shown in Figure F are to be observed for Top layer copper traces and vias. Internal layers buried one or more layers may be exempt, depending on the PCB material grade and thickness. Users are advised to consult UL standards for details.

All layers including top and bottom, are subject to the keep out areas shown around Primary pins of BusQor module. Actual keep outs along the surface (Creepage) may vary depending on the PCB material CTI. Users are advised to consult UL standards for details.

Bridging Components: Bridging components like EMI filter capacitors required to be placed as close as possible to the BusQor module for optimum performance must observe the clearance/creepage requirements of 0.04" (40 mils) between pads to maintain compliance to UL standards for the overall power system.

Note: Referenced keep out widths are adequate to withstand UL's Basic Insulation Dielectric strength tests for approved PCB materials. Applications requiring Double or Reinforced insulation must double the keep out widths shown in Figure F. Keep out areas shown have standard margins above UL's minimum requirements.

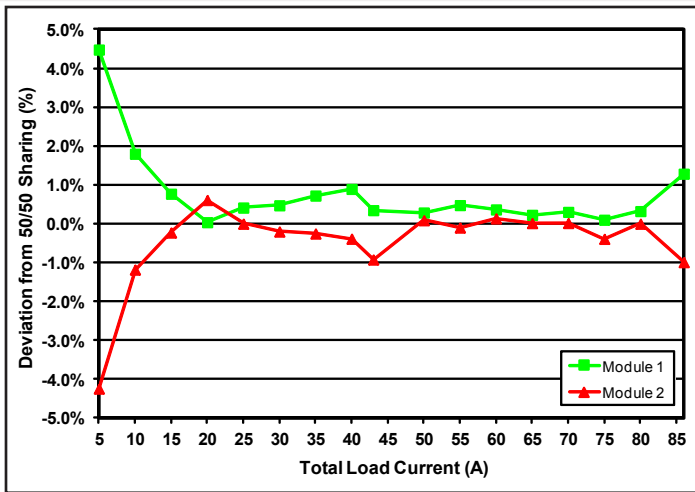

Figure G: Current share performance of 2 paralleled modules

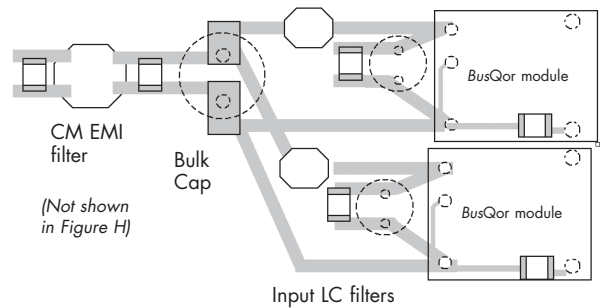

Figure H: Recommended PCB layout for input circuit

The current share performance of two paralleled modules is illustrated in the graph in Figure H. In this graph the percent deviation from ideal sharing (50%) is plotted for each module versus the total output load current at 48Vin.

Current Sharing: BusQor modules are designed to operate in parallel without the use of any external current share circuitry. A typical circuit for paralleling two BusQor modules is shown in Figure G. An output capacitor is recommended across each module and located close to the converter for optimum filtering and noise control performance. Dedicated input inductors are recommended but are considered optional. Input capacitors must be located close to the converter module. PCB layout in the input circuit should be such that high frequency ripple currents of each module is restricted to a loop formed by the input capacitors and the input terminals of the BusQor module. See Figure H for details on PCB layout. Contact SynQor application engineering for further assistance on PCB trace design.



Ordering Information

Input: 40-65 V
Output: 9.6 V
Current: 84A
Package: Quarter-brick

Part Numbering System

The part numbering system for SynQor's dc-dc converters follows the format shown in the example below.

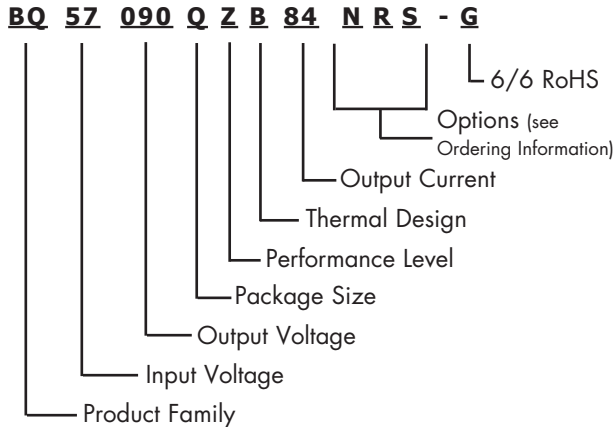

The first 12 characters comprise the base part number and the last 3 characters indicate available options. The "-G" suffix indicates 6/6 RoHS compliance.

Application Notes

A variety of application notes and technical white papers can be downloaded in pdf format from our [website](#).

RoHS Compliance: The EU led RoHS (Restriction of Hazardous Substances) Directive bans the use of Lead, Cadmium, Hexavalent Chromium, Mercury, Polybrominated Biphenyls (PBB), and Polybrominated Diphenyl Ether (PBDE) in Electrical and Electronic Equipment. This SynQor product is 6/6 RoHS compliant. For more information please refer to SynQor's RoHS addendum available at our [RoHS Compliance / Lead Free Initiative web page](#) or e-mail us at rohs@synqor.com.

Contact SynQor for further information and to order:

Phone: 978-849-0600
Toll Free: 888-567-9596
Fax: 978-849-0602
E-mail: power@synqor.com
Web: www.synqor.com
Address: 155 Swanson Road
 Boxborough, MA 01719
 USA

Ordering Information

The tables below show the valid model numbers and ordering options for converters in this product family. When ordering SynQor converters, please ensure that you use the complete 15 character part number consisting of the 12 character base part number and the additional characters for options. Add "-G" to the model number for 6/6 RoHS compliance.

Model Number	Input Voltage	Output Voltage	Max Output Current
BQ57090QZw84xyz-G	40-65 V	9.6 V	84 A

The following options must be included in place of the **wxyz** spaces in the model numbers listed above.

Options Description: w x y z			
Thermal Design	Enable Logic	Pin Style	Feature Set
B - Baseplated	N - Negative	N - 0.145" R - 0.180"	S - Standard

Not all combinations make valid part numbers, please contact SynQor for availability.

PATENTS

SynQor holds numerous U.S. patents, one or more of which apply to most of its power converter products. Any that apply to the product(s) listed in this document are identified by markings on the product(s) or on internal components of the product(s) in accordance with U.S. patent laws. SynQor's patents include the following:

5,999,417	6,222,742	6,545,890	6,594,159	6,731,520	6,894,468
6,896,526	6,927,987	7,050,309	7,072,190	7,085,146	7,119,524
7,269,034	7,272,021	7,272,023	7,558,083	7,564,702	7,765,687
7,787,261	8,023,290	8,149,597	8,493,751	8,644,027	

WARRANTY

SynQor offers a three (3) year limited warranty. Complete warranty information is listed on our website or is available upon request from SynQor.