

THIS DRAWING IS UNPUBLISHED. RELEASED FOR PUBLICATION  
 © COPYRIGHT - By - ALL RIGHTS RESERVED.

LOC	DIST	REVISIONS					
AF	50	P	LTR	DESCRIPTION	DATE	DWN	APVD
			K	REVISED PER ECR-12-013459	28NOV2012	KH	PD

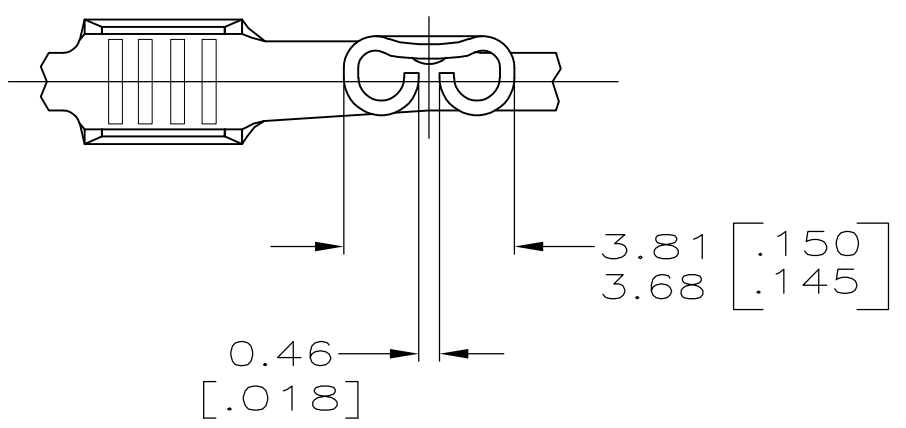

- 1 CONTINUOUS STRIP ON REELS.
- 2 PART MUST BE REELED ON TO PLASTIC REELS.
- 3 PRELIMINARY - NOT FOR PRODUCTION

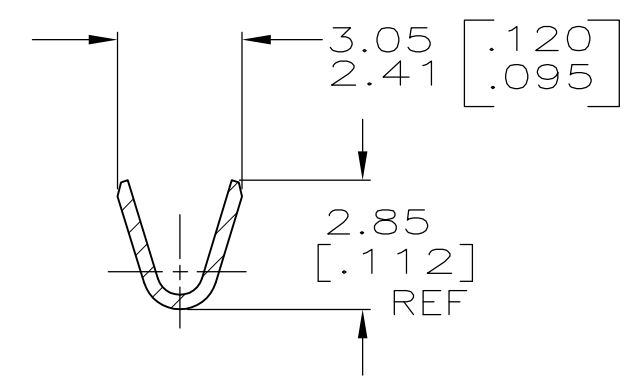
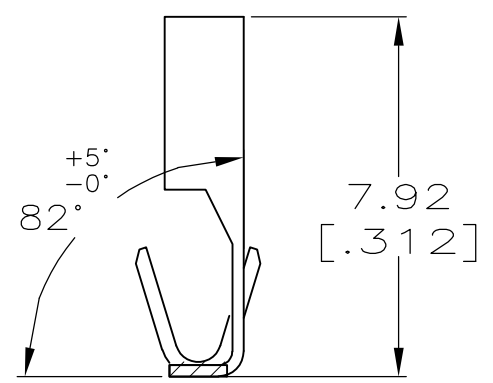
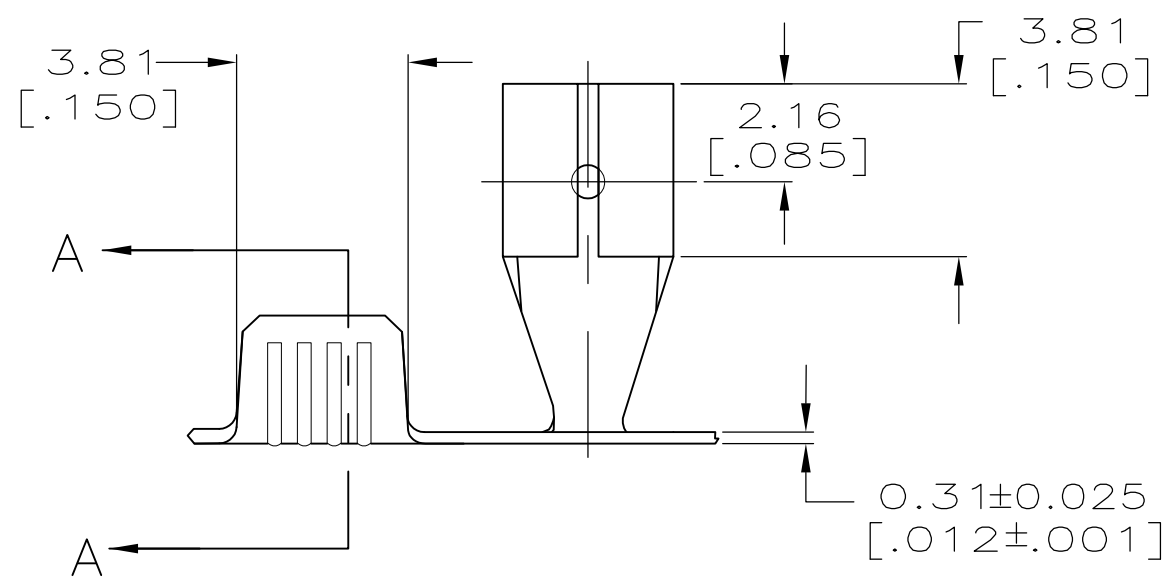

3 2	[#22-#16] AWG	0.51±0.025 [.020±.001]	60991-3
	[#22-#16] AWG	0.51±0.025 [.020±.001]	60991-1
	WIRE SIZE	MATING TAB THICKNESS	PART NO

4.77 [.188]	F	2.03 [.080]	1.52 [.060]	16
			1.32 [.052]	18
			1.19 [.047]	20
			1.11 [.044]	22
STRIP LENGTH ±0.38 [.015]	TYPE	WIDTH	±0.051 [.002] HEIGHT	WIRE
WIRE BARREL CRIMP				

THIS DRAWING IS A CONTROLLED DOCUMENT.

DIMENSIONS: mm [INCHES]	TOLERANCES UNLESS OTHERWISE SPECIFIED:
	0 PLC ± -
	1 PLC ± -
	2 PLC ± 0.25 [.010]
	3 PLC ± -
4 PLC ± -	± -
ANGLES	FINISH
	-
MATERIAL	
BRASS	

DWN	JR RUTH	4/3/95	<b>STE</b> TE Connectivity					
CHK	MS FEHER	4/3/95						
APVD	P DESANTIS	4/3/95						
PRODUCT SPEC								
APPLICATION SPEC	114-2028		NAME	RECEPTACLE, FASTON, 2.79 [.110] SERIES				
WEIGHT	-		SIZE	CAGE CODE	DRAWING NO	RESTRICTED TO		
CUSTOMER DRAWING			A3	00779	C-60991	-		
			SCALE	6:1	SHEET	1 OF 1	REV	K