

6

5

4

3

2

1

APPROVED: _____

DATE: _____ TITLE: _____

Rev	AWO #	Description	Date	Appr
-		RELEASED	3/30/16	
A		UPDATED SPEC.	6/20/16	HR/CK

D

D

C

C

B

B

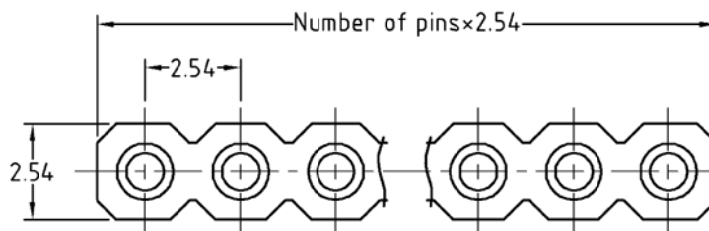
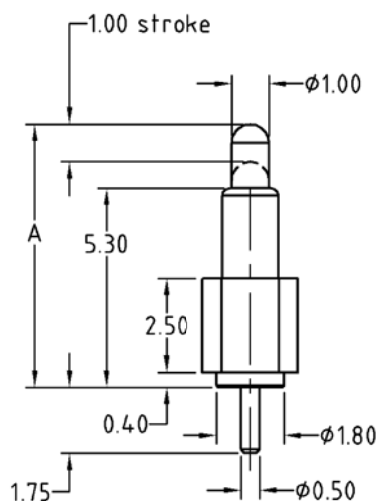

Positions: 01 thru 40

ADAM P/N	Initial Height
PH1-3B-XX-MV5P-5365	6.5mm
PH1-3B-XX-MV5P-5370	7.0mm
PH1-3B-XX-MV5P-5375	7.5mm
PH1-3B-XX-MV5P-5380	8.0mm

SPECIFICATIONS:

Material:

Insulator: Black plastics, Color: Black, rated UL 94V-0

Plunger: Brass, Gold plated

Barrel: Brass, Gold plated

Spring: SUS Surface treatment

Electrical:

Voltage rating: 12 VDC max

Current rating: 5 A max

Contact resistance: 20 mohms max

Mechanical:

Spring force: 70g±20g @ 1.0mm working stroke

Full stroke: 1.40mm

Life test: 1,000,000 Cycles

Temperature Rating:

Operating temperature: -40°C to +80°C

Environmental:

Lead free, RoHS compliant.



UNLESS OTHERWISE SPECIFIED ALL DIMENSIONS ARE MILLIMETERS TOLERANCES: EXCEPT AS NOTED HOLES		ADAM TECH 909 Rahway Avenue, Union, NJ 07083 Phone: 908-687-5000 Fax: 908-687-5710	
.X ± .25	∅.XX ± .013		
.XX ± .15		TITLE CUSTOM LENGTH TUBE SINGLE ROW STRIPS 2.50MM INSULATOR HEIGHT, DIP, HI-CURRENT	
.XXX ± .05			
APPROVALS		DATE	
DRAWN	HR	3/30/16	
CHECKED	CK	3/30/16	
APPROVED			
SIZE	PART NO.	REV.	
X	PH1-3B-XX-MV5P-53XX	A	
REF:	S00170C	SCALE:	NTS
		SHEET 1 OF 1	

6

5

4

3

2

1

A