



4 Mbit (512 Kbit x 8) Low Power SRAM with Output Enable

FEATURES SUMMARY

- ULTRA LOW DATA RETENTION CURRENT
 - 100nA (typical)
 - 10µA (max)
- OPERATION VOLTAGE: 5.0V ± 10%
- 512 Kbit x 8 SRAM WITH OUTPUT ENABLE
- EQUAL CYCLE and ACCESS TIMES: 70ns
- LOW V_{CC} DATA RETENTION: 2.0V
- TRI-STATE COMMON I/O
- CMOS FOR OPTIMUM SPEED/POWER
- AUTOMATIC POWER-DOWN WHEN DESELECTED
- INTENDED FOR USE WITH ST ZEROPOWER[®] AND TIMEKEEPER[®] CONTROLLERS

Figure 1. Package

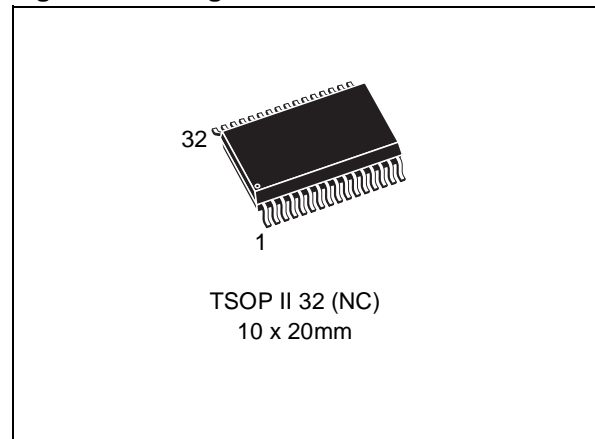

TABLE OF CONTENTS

DESCRIPTION 3

 Logic Diagram (Figure 2.) 3

 Signal Names (Table 1.) 3

 TSOP Connections (Figure 3.) 3

 Block Diagram (Figure 4.) 4

MAXIMUM RATING. 4

 Absolute Maximum Ratings (Table 2.) 4

DC AND AC PARAMETERS. 5

 DC and AC Measurement Conditions (Table 3.) 5

 AC Testing Load Circuit (Figure 5.) 5

 Capacitance (Table 4.) 5

 DC Characteristics (Table 5.) 6

OPERATION 6

 Operating Modes (Table 6.) 6

 READ Mode. 7

 Address Controlled, READ Mode AC Waveforms (Figure 6.) 7

 Chip Enable or Output Enable Controlled, READ Mode AC Waveforms (Figure 7.) 7

 Standby Mode AC Waveforms (Figure 8.) 7

 READ and Standby Modes AC Characteristics (Table 7.) 8

 WRITE Mode 9

 WRITE Enable Controlled, WRITE Mode AC Waveforms (Figure 9.) 9

 Chip Enable Controlled, WRITE Mode AC Waveforms (Figure 10.) 10

 WRITE Mode AC Characteristics (Table 8.) 10

 Low VCC Data Retention AC Waveforms (Figure 11.) 11

 Low VCC Data Retention Characteristics (Table 9.) 11

PART NUMBERING 12

PACKAGE MECHANICAL INFORMATION 13

REVISION HISTORY. 14

DESCRIPTION

The M68Z512 is a 4 Mbit (4,194,304 bit) CMOS SRAM, organized as 524,288 words by 8 bits. The device features fully static operation requiring no external clocks or timing strobes, with equal address access and cycle times. It requires a single 5V ±10% supply, and all inputs and outputs are TTL compatible.

This device has an automatic power-down feature, reducing the power consumption by over 99% when deselected.

The M68Z512 is available in a 32-lead TSOP II (10 x 20mm) package.

Figure 2. Logic Diagram

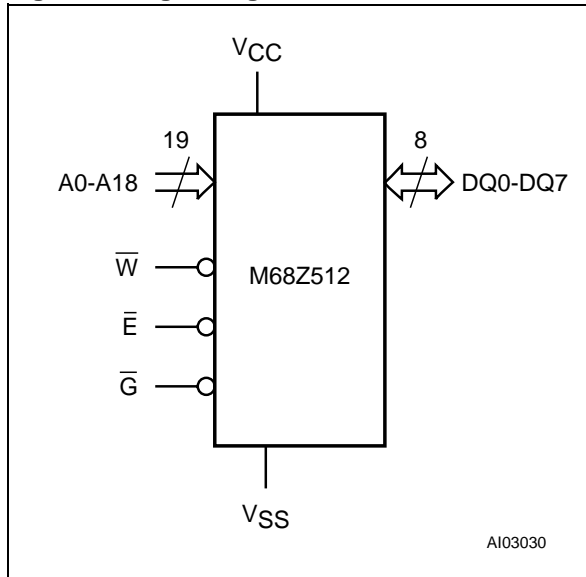

Table 1. Signal Names

A0-A18	Address Inputs
DQ0-DQ7	Data Input/Output
\bar{E}	Chip Enable
\bar{G}	Output Enable
\bar{W}	Write Enable
VCC	Supply Voltage
VSS	Ground

Figure 3. TSOP Connections

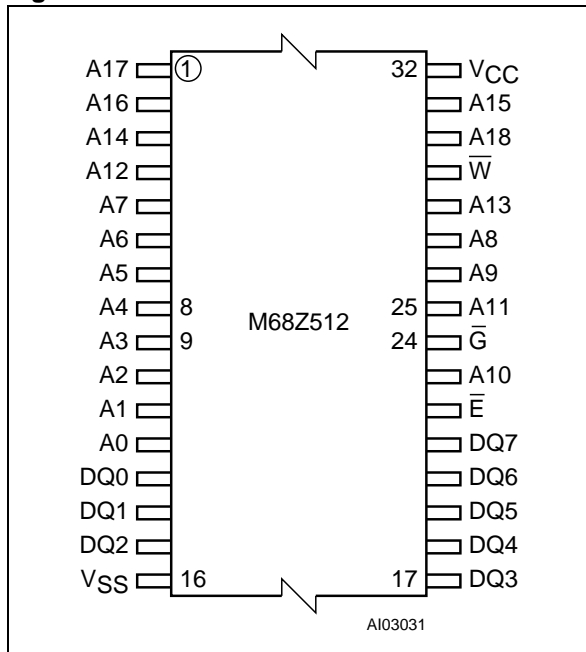
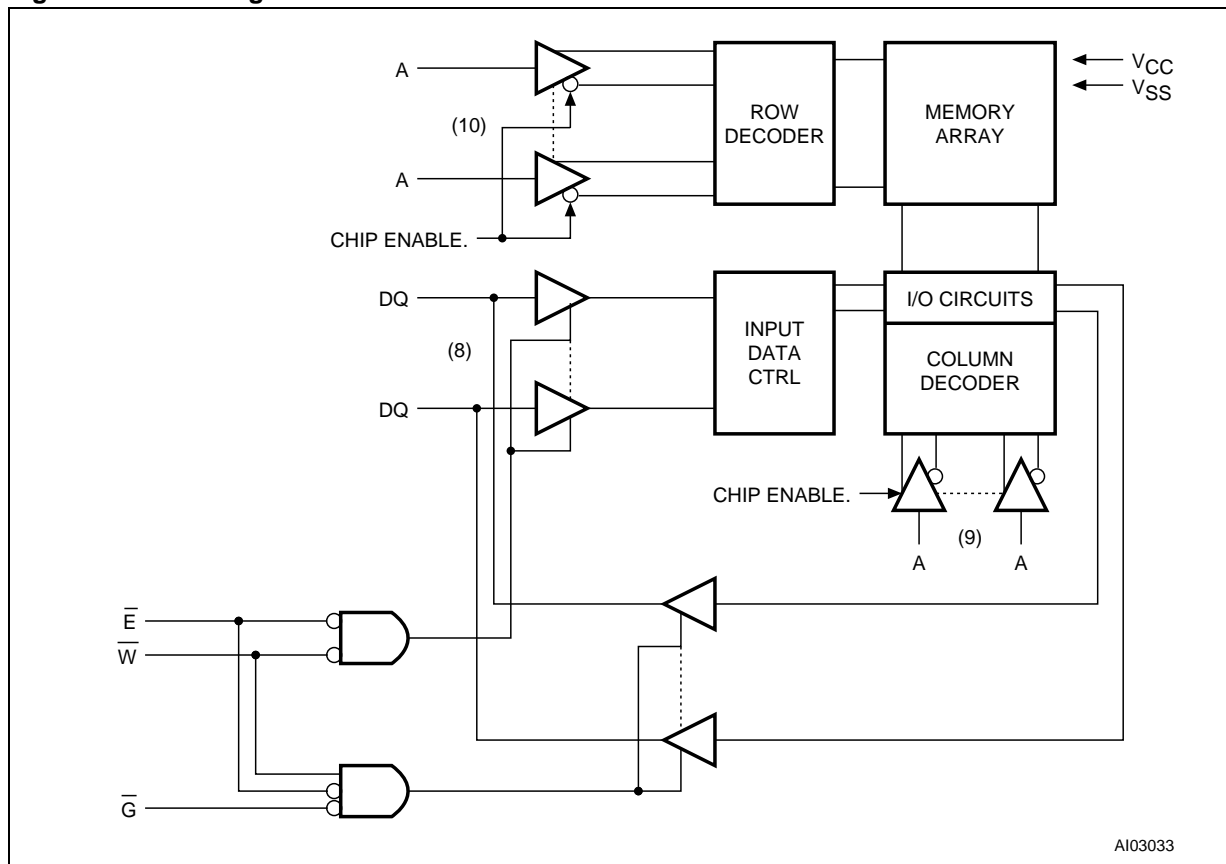

Figure 4. Block Diagram



MAXIMUM RATING

Stressing the device above the rating listed in the “Absolute Maximum Ratings” table may cause permanent damage to the device. These are stress ratings only and operation of the device at these or any other conditions above those indicated in the Operating sections of this specification is

not implied. Exposure to Absolute Maximum Rating conditions for extended periods may affect device reliability. Refer also to the STMicroelectronics SURE Program and other relevant quality documents.

Table 2. Absolute Maximum Ratings

Symbol	Parameter	Value	Unit
T _A	Ambient Operating Temperature	0 to 70	°C
T _{STG} ⁽¹⁾	Storage Temperature	-65 to 150	°C
V _{IO} ⁽²⁾	Input or Output Voltage	-0.3 to V _{CC} + 0.3	V
V _{CC}	Supply Voltage	-0.3 to 7.0	V
I _O ⁽³⁾	Output Current	20	mA
P _D	Power Dissipation	1	W

Note: 1. Reflow at peak temperature of 215°C to 225°C for < 60 seconds (total thermal budget not to exceed 180°C for between 90 to 120 seconds).
 2. Up to a maximum operating V_{CC} of 5.5V only.
 3. One output at a time, not to exceed 1 second duration.

DC AND AC PARAMETERS

This section summarizes the operating and measurement conditions, as well as the DC and AC characteristics of the device. The parameters in the following DC and AC Characteristic tables are derived from tests performed under the Measure-

ment Conditions listed in the relevant tables. Designers should check that the operating conditions in their projects match the measurement conditions when using the quoted parameters.

Table 3. DC and AC Measurement Conditions

Parameter	M68Z512
V _{CC} Supply Voltage	4.5 to 5.5V
Ambient Operating Temperature	0 to 70°C
Load Capacitance (C _L)	100pF
Input Rise and Fall Times	≤ 5ns
Input Pulse Voltages	0 to 3V
Input and Output Timing Ref. Voltages	1.5V

Note: Output High Z is defined as the point where data is no longer driven (see Table 3, page 5).

Figure 5. AC Testing Load Circuit

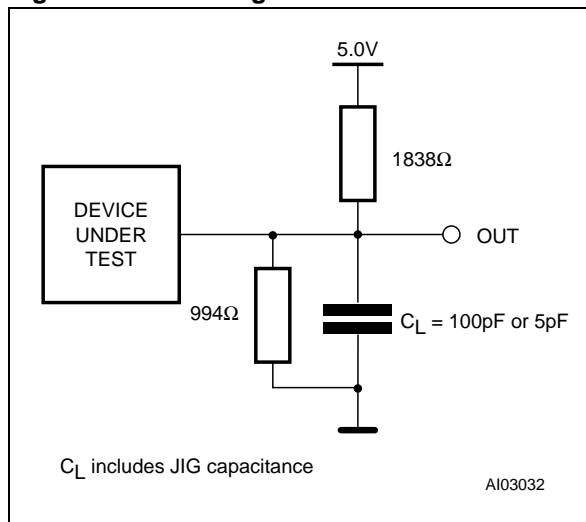

Table 4. Capacitance

Symbol	Parameter ^(1,2)	Min	Max	Unit
C _{IN}	Input Capacitance on all pins (except DQ)		6	pF
C _{OUT} ⁽³⁾	Output Capacitance		8	pF

Note: 1. Sampled only, not 100% tested.
 2. Outputs deselected.
 3. At 25°C.

Table 5. DC Characteristics

Symbol	Parameter	Test Condition ⁽¹⁾	Min	Typ	Max	Unit
I_{LI}	Input Leakage Current	$0V \leq V_{IN} \leq V_{CC}$			± 1	μA
I_{LO}	Output Leakage Current	$0V \leq V_{OUT} \leq V_{CC}$			± 1	μA
$I_{CC1}^{(2)}$	Supply Current	$V_{CC} = 3.6V$			90	mA
$I_{CC2}^{(3)}$	Supply Current (Standby) TTL	$V_{CC} = 3.6V, \bar{E} = V_{IH}$			15	mA
$I_{CC3}^{(4)}$	Supply Current (Standby) CMOS	$V_{CC} = 3.6V, \bar{E} \geq V_{CC} - 0.3V, f = 0$		1.6	20	μA
V_{IL}	Input Low Voltage		-0.3		0.8	V
V_{IH}	Input High Voltage		2.2		$V_{CC} + 0.3$	V
V_{OL}	Output Low Voltage	$I_{OL} = 2.1mA$			0.4	V
V_{OH}	Output High Voltage	$I_{OH} = -1mA$	2.4			V

Note: 1. Valid for Ambient Operating Temperature: $T_A = 0$ to $70^\circ C$; $V_{CC} = 4.5$ to $5.5V$ (except where noted).

2. Average AC current, Outputs open, cycling at t_{AVAV} minimum.

3. All other Inputs at $V_{IL} \leq 0.8V$ or $V_{IH} \geq 2.2V$.

4. All other Inputs at $V_{IL} \leq 0.3V$ or $V_{IH} \geq V_{CC} - 0.3V$.

OPERATION

The M68Z512 has a Chip Enable power down feature which invokes an automatic standby mode whenever Chip Enable is de-asserted ($\bar{E} = \text{High}$). An Output Enable (\bar{G}) signal provides a high speed tri-state control, allowing fast READ/WRITE

Cycles to be achieved with the common I/O data bus. Operational modes are determined by device control inputs \bar{W} and \bar{E} as summarized in the Operating Modes table (see Table 6).

Table 6. Operating Modes

Operation	\bar{E}	\bar{W}	\bar{G}	DQ0-DQ7	Power
Read	V_{IL}	V_{IH}	V_{IH}	Hi-Z	Active
Read	V_{IL}	V_{IH}	V_{IL}	Data Output	Active
Write	V_{IL}	V_{IL}	X	Data Input	Active
Deselect	V_{IH}	X	X	Hi-Z	Standby

Note: X = V_{IH} or V_{IL} .

READ Mode

The M68Z512 is in the READ mode whenever Write Enable (\overline{W}) is High with Output Enable (\overline{G}) Low, and Chip Enable (\overline{E}) is asserted. This provides access to data from eight of the 4,194,304 locations in the static memory array, specified by the 19 address inputs. Valid data will be available at the eight output pins within t_{AVQV} after the last

stable address, providing \overline{G} is Low and \overline{E} is Low. If Chip Enable or Output Enable access times are not met, data access will be measured from the limiting parameter (t_{ELQV} or t_{GLQV}) rather than the address. Data out may be indeterminate at t_{ELQX} and t_{GLQX} , but data lines will always be valid at t_{AVQV} .

Figure 6. Address Controlled, READ Mode AC Waveforms

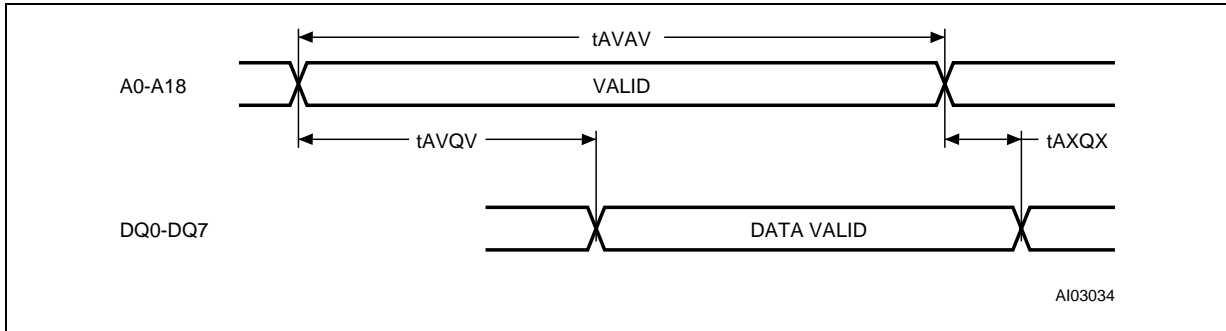

Note: \overline{E} = Low, $\overline{E}2$ = High, $+\overline{G}$ = Low, \overline{W} = High.

Figure 7. Chip Enable or Output Enable Controlled, READ Mode AC Waveforms

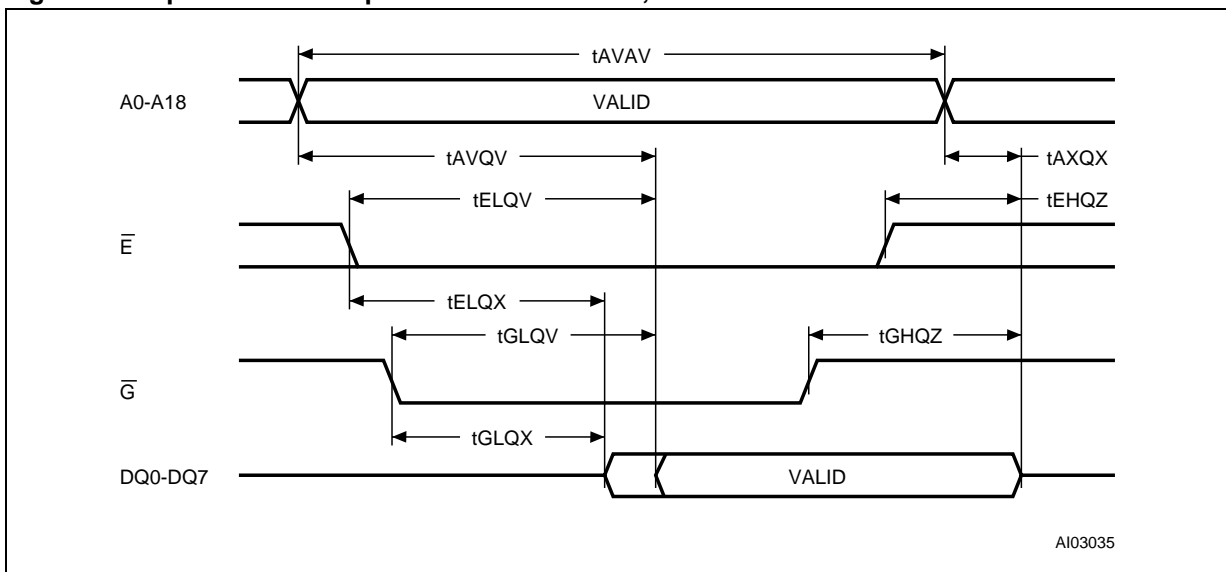

Note: Write Enable (\overline{W}) = High.

Figure 8. Standby Mode AC Waveforms

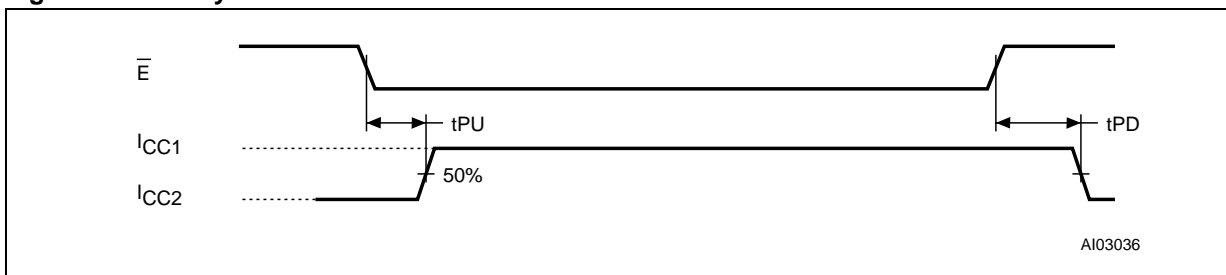

Table 7. READ and Standby Modes AC Characteristics

Symbol	Parameter ⁽¹⁾	M68Z512		Unit
		-70		
		Min	Max	
t _{AVAV}	READ Cycle Time	70		ns
t _{AVQV} ⁽²⁾	Address Valid to Output Valid		70	ns
t _{ELQV} ⁽²⁾	Chip Enable Low to Output Valid		70	ns
t _{GLQV} ⁽²⁾	Output Enable Low to Output Valid		35	ns
t _{ELQX} ⁽⁴⁾	Chip Enable Low to Output Transition	10		ns
t _{GLQX} ⁽⁴⁾	Output Enable Low to Output Transition	5		ns
t _{EHQZ} ^(3,4)	Chip Enable High to Output Hi-Z		25	ns
t _{GHQZ} ⁽³⁾	Output Enable High to Output Hi-Z		25	ns
t _{AXQX} ⁽²⁾	Address Transition to Output Transition	10		ns
t _{PU}	Chip Enable Low to Power Up	0		ns
t _{PD}	Chip Enable High to Power Down		70	ns

Note: 1. Valid for Ambient Operating Temperature: T_A = 0 to 70°C; V_{CC} = 4.5 to 5.5V (except where noted).

2. C_L = 100pF.

3. C_L = 5pF.

4. At any given temperature and voltage condition, t_{EHQZ} is less than t_{ELQX} and t_{GHQZ} is less than t_{GLQX} for any given device.

WRITE Mode

The M68Z512 is in the WRITE mode whenever the \overline{W} and \overline{E} pins are Low. Either the Chip Enable input (\overline{E}) or the WRITE Enable input (\overline{W}) must be deasserted during Address transitions for subsequent WRITE cycles. Write begins with the concurrence of Chip Enable being active with \overline{W} low. Therefore, address setup time is referenced to WRITE Enable and Chip Enable as t_{AVWL} and t_{AVEH} respectively, and is determined by the latter occurring edge.

The WRITE Cycle can be terminated by the earlier rising edge of \overline{E} , or \overline{W} .

If the Output is enabled ($\overline{E} = \text{Low}$ and $\overline{G} = \text{Low}$), then \overline{W} will return the outputs to high impedance within t_{WLQZ} of its falling edge. Care must be taken to avoid bus contention in this type of operation. Data input must be valid for t_{DVWH} before the rising edge of WRITE Enable, or for t_{DVEH} before the rising edge of \overline{E} , whichever occurs first, and remain valid for t_{WHDX} or t_{EHDX} .

Figure 9. WRITE Enable Controlled, WRITE Mode AC Waveforms

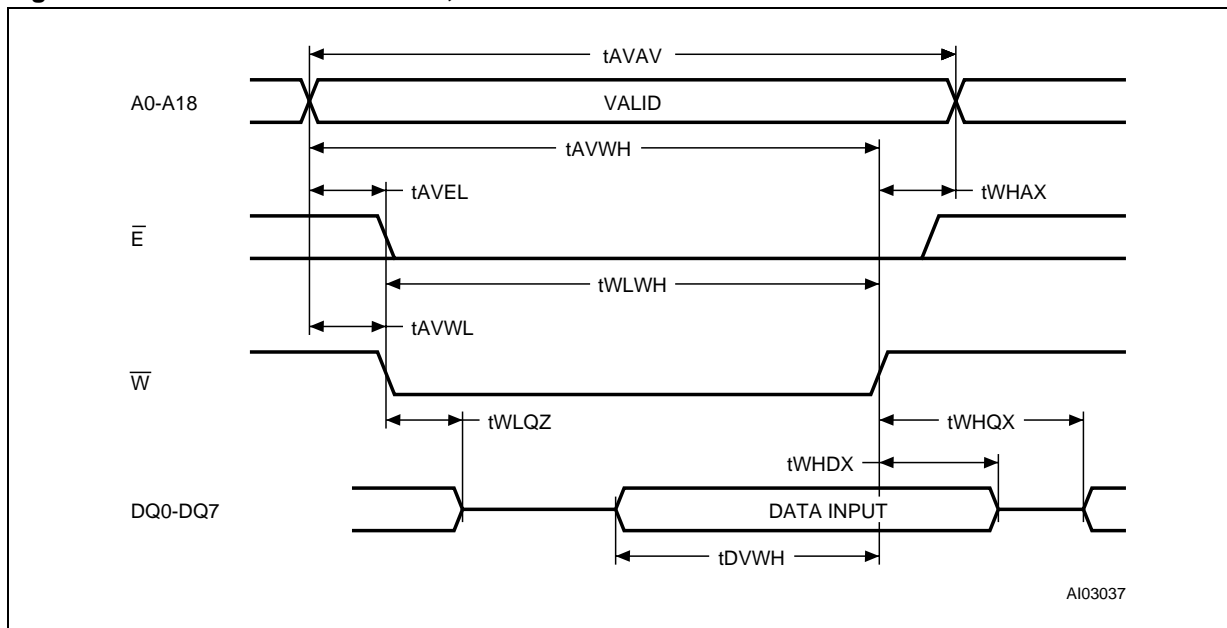

Note: Output Enable (\overline{G}) = Low.

Figure 10. Chip Enable Controlled, WRITE Mode AC Waveforms

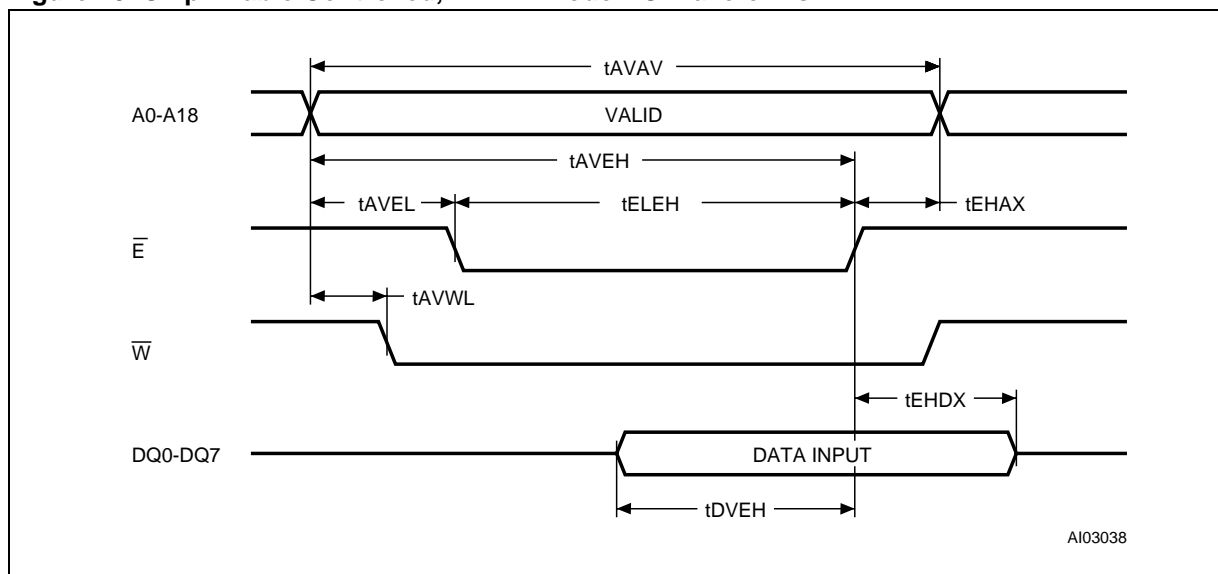

Note: Output Enable (\bar{G}) = High.
 If \bar{E} goes High with \bar{W} High, the output remains in a high-impedance state.

Table 8. WRITE Mode AC Characteristics

Symbol	Parameter ⁽¹⁾	M68Z512		Unit
		-70		
		Min	Max	
t_{AVAV}	WRITE Cycle Time	70		ns
t_{AVWL}	Address Valid to WRITE Enable Low	0		ns
t_{AVWH}	Address Valid to WRITE Enable High	60		ns
t_{AVEH}	Address Valid to Chip Enable High	60		ns
t_{WLVH}	WRITE Enable Pulse Width	55		ns
t_{WHAX}	WRITE Enable High to Address Transition	0		ns
t_{WHDX}	WRITE Enable High to Input Transition	0		ns
$t_{WHQX}^{(3)}$	WRITE Enable High to Output Transition	5		ns
$t_{WLQZ}^{(2,3)}$	WRITE Enable Low to Output Hi-Z		25	ns
t_{AVEL}	Address Valid to Chip Enable Low	0		ns
t_{ELEV}	Chip Enable Low to Chip Enable High	45		ns
t_{EHAX}	Chip Enable High to Address Transition	0		ns
t_{DVWH}	Input Valid to WRITE Enable High	25		ns
t_{DVEH}	Input Valid to Chip Enable High	25		ns

Note: 1. Valid for Ambient Operating Temperature: $T_A = 0$ to 70°C ; $V_{CC} = 4.5$ to 5.5V (except where noted).
 2. $C_L = 5\text{pF}$
 3. At any given temperature and voltage condition, t_{WLQZ} is less than t_{WHQX} for any given device.

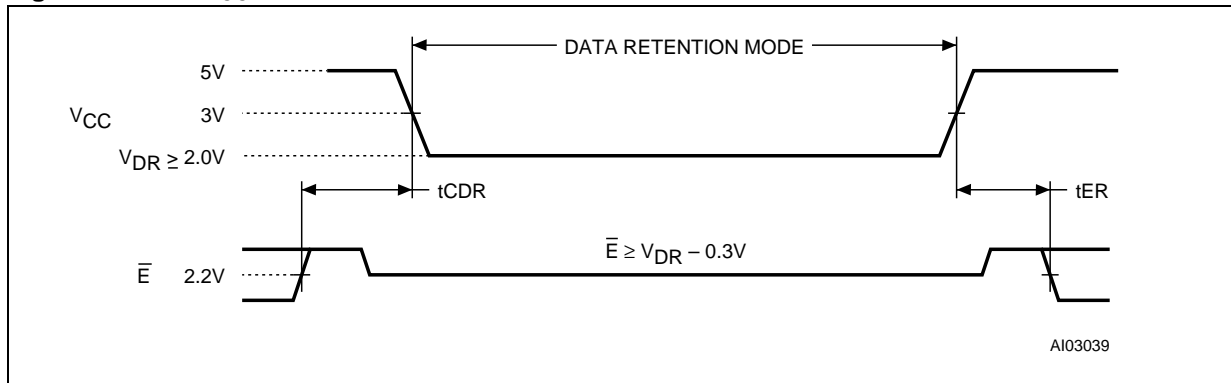
Figure 11. Low V_{CC} Data Retention AC WaveformsTable 9. Low V_{CC} Data Retention Characteristics

Symbol	Parameter ⁽¹⁾	Test Condition	Min	Typ	Max	Unit
$I_{CCDR}^{(2)}$	Supply Current (Data Retention)	$V_{CC} = 3V, \bar{E} \geq V_{CC} - 0.3V$		0.4	10	μA
V_{DR}	Supply Voltage (Data Retention)	$\bar{E} \geq V_{CC} - 0.3V, f = 0$	2			V
t_{CDR}	Chip Disable to Power Down	$\bar{E} \geq V_{CC} - 0.3V, f = 0$	0			ns
$t_{ER}^{(3)}$	Operation Recovery Time		t_{AVAV}			ns

Note: 1. Valid for Ambient Operating Temperature: $T_A = 0$ to $70^\circ C$; $V_{CC} = 4.5$ to $5.5V$ (except where noted).

2. Typical condition: $T_A = 25^\circ C$.

3. See Figure 11 for measurement points. Guaranteed but not tested. t_{AVAV} is READ Cycle time.

PART NUMBERING

Table 10. Ordering Information Example

Example:	M68Z	512	W	-70	NC	1	TR
Device Type							
M68Z							
Device Function							
512 = 4 Mbit (512Kb x8)							
Operating Voltage							
blank = 4.5 to 5.5V							
Speed							
-70 = 70ns							
Package							
NC = TSOP II 32-Lead (10 x 20mm)							
Temperature Range							
1 = 0 to 70°C							
Shipping Method for SOIC							
blank = Tubes							
TR = Tape & Reel							

For a list of available options (e.g., Speed, Package) or for further information on any aspect of this device, please contact the ST Sales Office nearest to you.

PACKAGE MECHANICAL INFORMATION

Figure 12. TSOP II 32 – 32-lead Plastic Thin Small Outline II, 10 x 20 mm, Package Outline

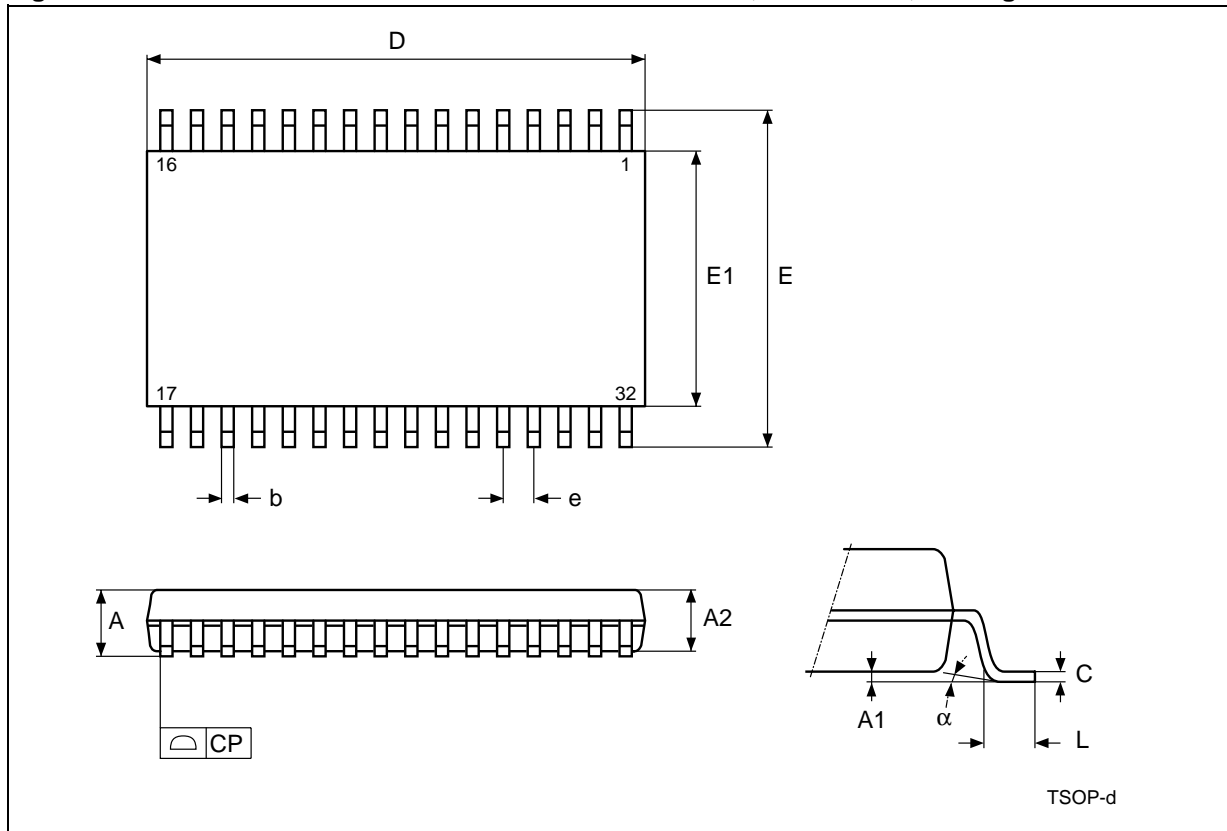

Note: Drawing is not to scale.

Table 11. TSOP II 32 – 32-lead Plastic Thin Small Outline II, 10 x 20 mm, Package Mechanical Data

Symb	mm			inches		
	Min	Typ	Max	Min	Typ	Max
A			1.20			0.047
A1		0.05	0.15		0.002	0.006
A2		0.95	1.05		0.037	0.041
b		0.30	0.52		0.012	0.020
C		0.12	0.21		0.005	0.008
CP			0.10			0.004
D		20.82	21.08		0.820	0.830
e	1.27	–	–	0.050	–	–
E		11.56	11.96		0.455	0.471
E1		10.03	10.29		0.395	0.405
L		0.40	0.60		0.016	0.024
α		0°	5°		0°	5°
N		32			32	

REVISION HISTORY**Table 12. Document Revision History**

Date	Revision Details
May 1999	First Issue
03/14/00	TSOP32 II Package Dimension Changed (Table 11) From Preliminary Data to Data Sheet
07/26/00	Ordering Information Scheme changed (Table 10)
09/21/00	ICCDR Supply Current changed (Table 9)
03/30/01	Reformatted; temp./voltage info. added to tables (Table 4, 5, 7, 8, 9)
05/13/02	Add reflow time and temperature footnote (Table 2)

Information furnished is believed to be accurate and reliable. However, STMicroelectronics assumes no responsibility for the consequences of use of such information nor for any infringement of patents or other rights of third parties which may result from its use. No license is granted by implication or otherwise under any patent or patent rights of STMicroelectronics. Specifications mentioned in this publication are subject to change without notice. This publication supersedes and replaces all information previously supplied. STMicroelectronics products are not authorized for use as critical components in life support devices or systems without express written approval of STMicroelectronics.

The ST logo is registered trademark of STMicroelectronics
All other names are the property of their respective owners.

© 2002 STMicroelectronics - All Rights Reserved

STMicroelectronics GROUP OF COMPANIES
Australia - Brazil - Canada - China - Finland - France - Germany - Hong Kong - India - Israel - Italy - Japan - Malaysia -
Malta - Morocco - Singapore - Spain - Sweden - Switzerland - United Kingdom - U.S.A.

www.st.com