

**RADIATION HARDENED  
 POWER MOSFET  
 THRU-HOLE (MO-036AB)**

**IRHG597110**  
**100V, Quad P-CHANNEL**  
**RAD-Hard™ HEXFET®**  
**TECHNOLOGY**

**Product Summary**

| Part Number | Radiation Level | R <sub>DS(on)</sub> | I <sub>D</sub> |
|-------------|-----------------|---------------------|----------------|
| IRHG597110  | 100K Rads (Si)  | 0.96Ω               | -0.96A         |
| IRHG593110  | 300K Rads (Si)  | 0.98Ω               | -0.96A         |



International Rectifier's RAD-Hard™ HEXFET® MOSFET Technology provides high performance power MOSFETs for space applications. This technology has over a decade of proven performance and reliability in satellite applications. These devices have been characterized for both Total Dose and Single Event Effects (SEE). The combination of low R<sub>DS(on)</sub> and low gate charge reduces the power losses in switching applications such as DC to DC converters and motor control. These devices retain all of the well established advantages of MOSFETs such as voltage control, fast switching, ease of paralleling and temperature stability of electrical parameters.

**Features:**

- Single Event Effect (SEE) Hardened
- Low R<sub>DS(on)</sub>
- Low Total Gate Charge
- Proton Tolerant
- Simple Drive Requirements
- Ease of Paralleling
- Hermetically Sealed
- Ceramic Package
- Light Weight
- ESD Rating: Class 1A per MIL-STD-750, Method 1020

**Absolute Maximum Ratings (Per Die)**

**Pre-Irradiation**

|   | Parameter                       |  | Units |
|---|---------------------------------|--|-------|
| I <sub>D</sub> @ V <sub>GS</sub> = -12V, T <sub>C</sub> = 25°C  | Continuous Drain Current        | -0.96                                  | A     |
| I <sub>D</sub> @ V <sub>GS</sub> = -12V, T <sub>C</sub> = 100°C | Continuous Drain Current        | -0.6                                   |       |
| I <sub>DM</sub>   | Pulsed Drain Current ①          | -3.84                                  |       |
| P <sub>D</sub> @ T <sub>C</sub> = 25°C                          | Max. Power Dissipation          | 1.4                                    | W     |
|   | Linear Derating Factor          | 0.011                                  | W/°C  |
| V <sub>GS</sub>   | Gate-to-Source Voltage          | ± 20                                   | V     |
| EAS   | Single Pulse Avalanche Energy ② | 200                                    | mJ    |
| I <sub>AR</sub>   | Avalanche Current ①             | -0.96                                  | A     |
| EAR   | Repetitive Avalanche Energy ①   | 0.14                                   | mJ    |
| dv/dt   | Peak Diode Recovery dv/dt ③     | 7.1                                    | V/ns  |
| T <sub>J</sub>  | Operating Junction              | -55 to 150                             | °C    |
| T <sub>STG</sub>  | Storage Temperature Range       |  |       |
|   | Lead Temperature                | 300 (0.63 in./1.6mm from case for 10s) |       |
|   | Weight                          | 1.3 (Typical)                          | g     |

For footnotes refer to the last page

**Electrical Characteristics For Each P-Channel Device @ T<sub>j</sub> = 25°C (Unless Otherwise Specified)**

|                                     | Parameter                                    | Min  | Typ   | Max  | Units | Test Conditions   |
|-------------------------------------|--|------|-------|------|-------|---|
| BV <sub>DSS</sub>                   | Drain-to-Source Breakdown Voltage            | -100 | —     | —    | V     | V <sub>GS</sub> = 0V, I <sub>D</sub> = -1.0mA   |
| ΔBV <sub>DSS</sub> /ΔT <sub>J</sub> | Temperature Coefficient of Breakdown Voltage | —    | -0.14 | —    | V/°C  | Reference to 25°C, I <sub>D</sub> = -1.0mA  |
| R <sub>DS(on)</sub>                 | Static Drain-to-Source On-State Resistance   | —    | —     | 0.96 | Ω     | V <sub>GS</sub> = -12V, I <sub>D</sub> = -0.6A ④  |
| V <sub>GS(th)</sub>                 | Gate Threshold Voltage                       | -2.0 | —     | -4.0 | V     | V <sub>DS</sub> = V <sub>GS</sub> , I <sub>D</sub> = -1.0mA   |
| g <sub>fs</sub>                     | Forward Transconductance                     | 1.1  | —     | —    | S     | V <sub>DS</sub> = -15V, I <sub>DS</sub> = -0.6A ④   |
| I <sub>DSS</sub>                    | Zero Gate Voltage Drain Current              | —    | —     | -10  | μA    | V <sub>DS</sub> = -80V, V <sub>GS</sub> = 0V  |
|                                     |  | —    | —     | -25  |       | V <sub>DS</sub> = -80V,<br>V <sub>GS</sub> = 0V, T <sub>J</sub> = 125°C   |
| I <sub>GSS</sub>                    | Gate-to-Source Leakage Forward               | —    | —     | -100 | nA    | V <sub>GS</sub> = -20V  |
| I <sub>GSS</sub>                    | Gate-to-Source Leakage Reverse               | —    | —     | 100  |       | V <sub>GS</sub> = 20V   |
| Q <sub>g</sub>                      | Total Gate Charge                            | —    | —     | 13.4 | nC    | V <sub>GS</sub> = -12V, I <sub>D</sub> = -0.96A,<br>V <sub>DS</sub> = -50V  |
| Q <sub>gs</sub>                     | Gate-to-Source Charge                        | —    | —     | 3.7  |       |   |
| Q <sub>gd</sub>                     | Gate-to-Drain ('Miller') Charge              | —    | —     | 3.0  |       |   |
| t <sub>d(on)</sub>                  | Turn-On Delay Time                           | —    | —     | 21   | ns    | V <sub>DD</sub> = -50V, I <sub>D</sub> = -0.96A,<br>V <sub>GS</sub> = -12V, R <sub>G</sub> = 7.5Ω   |
| t <sub>r</sub>                      | Rise Time                                    | —    | —     | 17   |       |   |
| t <sub>d(off)</sub>                 | Turn-Off Delay Time                          | —    | —     | 40   |       |   |
| t <sub>f</sub>                      | Fall Time                                    | —    | —     | 90   |       |   |
| LS + LD                             | Total Inductance                             | —    | 10    | —    | nH    | Measured from Drain lead (6mm /0.25in. from package) to Source lead (6mm /0.25in from package) with Source wires internally bonded from Source Pin to Drain Pad |
| C <sub>iss</sub>                    | Input Capacitance                            | —    | 390   | —    | pF    | V <sub>GS</sub> = 0V, V <sub>DS</sub> = 25V<br>f = 1.0MHz   |
| C <sub>oss</sub>                    | Output Capacitance                           | —    | 100   | —    |       |   |
| C <sub>rss</sub>                    | Reverse Transfer Capacitance                 | —    | 7.0   | —    |       |   |

**Source-Drain Diode Ratings and Characteristics (Per Die)**

|                 | Parameter                              | Min   | Typ | Max   | Units | Test Conditions   |
|-----------------|--|---|-----|-------|-------|---|
| I <sub>S</sub>  | Continuous Source Current (Body Diode) | —   | —   | -0.96 | A     | T <sub>j</sub> = 25°C, I <sub>S</sub> = -0.96A, V <sub>GS</sub> = 0V④ |
| I <sub>SM</sub> | Pulse Source Current (Body Diode) ①    | —   | —   | -3.84 |       |   |
| V <sub>SD</sub> | Diode Forward Voltage                  | —   | —   | -5.0  | V     | T <sub>j</sub> = 25°C, I <sub>F</sub> = -0.96A, di/dt ≤ -100A/μs      |
| t <sub>rr</sub> | Reverse Recovery Time                  | —   | —   | 86    | nS    | V <sub>DD</sub> ≤ -25V ④  |
| Q <sub>RR</sub> | Reverse Recovery Charge                | —   | —   | 240   | nC    |   |
| t <sub>on</sub> | Forward Turn-On Time                   | Intrinsic turn-on time is negligible. Turn-on speed is substantially controlled by LS + LD. |     |       |       |   |

**Thermal Resistance (Per Die)**

|                   | Parameter           | Min | Typ | Max | Units | Test Conditions      |
|-------------------|---------------------|-----|-----|-----|-------|----------------------|
| R <sub>thJA</sub> | Junction-to-Ambient | —   | —   | 90  | °C/W  | Typical socket mount |

Note: Corresponding Spice and Saber models are available on International Rectifier Website.

For footnotes refer to the last page

International Rectifier Radiation Hardened MOSFETs are tested to verify their radiation hardness capability. The hardness assurance program at International Rectifier is comprised of two radiation environments. Every manufacturing lot is tested for total ionizing dose (per notes 5 and 6) using the TO-3 package. Both pre- and post-irradiation performance are tested and specified using the same drive circuitry and test conditions in order to provide a direct comparison.

**Table 1. Electrical Characteristics @ Tj = 25°C, Post Total Dose Irradiation<sup>①②</sup> (Per Die)**

|                     | Parameter   | 100K Rads(Si) <sup>1</sup> |       | 300K Rads (Si) <sup>2</sup> |       | Units | Test Conditions   |
|---------------------|---|----------------------------|-------|-----------------------------|-------|-------|---|
|                     |   | Min                        | Max   | Min                         | Max   |       |   |
| BV <sub>DSS</sub>   | Drain-to-Source Breakdown Voltage                                     | -100                       | —     | -100                        | —     | V     | V <sub>GS</sub> = 0V, I <sub>D</sub> = -1.0mA               |
| V <sub>GS(th)</sub> | Gate Threshold Voltage  | -2.0                       | -4.0  | -2.0                        | -4.0  |       | V <sub>GS</sub> = V <sub>DS</sub> , I <sub>D</sub> = -1.0mA |
| I <sub>GSS</sub>    | Gate-to-Source Leakage Forward  | —                          | -100  | —                           | -100  | nA    | V <sub>GS</sub> = -20V                                      |
| I <sub>GSS</sub>    | Gate-to-Source Leakage Reverse  | —                          | 100   | —                           | 100   |       | V <sub>GS</sub> = 20 V                                      |
| I <sub>DSS</sub>    | Zero Gate Voltage Drain Current                                       | —                          | -10   | —                           | -10   | μA    | V <sub>DS</sub> = -80V, V <sub>GS</sub> = 0V                |
| R <sub>DS(on)</sub> | Static Drain-to-Source <sup>④</sup><br>On-State Resistance (TO-39)    | —                          | 0.916 | —                           | 0.936 | Ω     | V <sub>GS</sub> = -12V, I <sub>D</sub> = -0.6A              |
| R <sub>DS(on)</sub> | Static Drain-to-Source <sup>④</sup><br>On-State Resistance (MO-036AB) | —                          | 0.96  | —                           | 0.98  | Ω     | V <sub>GS</sub> = -12V, I <sub>D</sub> = -0.6A              |
| V <sub>SD</sub>     | Diode Forward Voltage <sup>④</sup>                                    | —                          | -3.5  | —                           | -3.5  | V     | V <sub>GS</sub> = 0V, I <sub>S</sub> = -0.96A               |

1. Part number IRHG597110
2. Part number IRHG593110

International Rectifier radiation hardened MOSFETs have been characterized in heavy ion environment for Single Event Effects (SEE). Single Event Effects characterization is illustrated in Fig. a and Table 2.

**Table 2. Typical Single Event Effect Safe Operating Area (Per Die)**

| LET<br>(MeV/(mg/cm <sup>2</sup> )) | Energy<br>(MeV) | Range<br>(μm) | V <sub>DS</sub> (V)      |                          |                           |                           |                           |
|------------------------------------|-----------------|---------------|--------------------------|--------------------------|---------------------------|---------------------------|---------------------------|
|                                    |                 |               | @V <sub>GS</sub> =<br>0V | @V <sub>GS</sub> =<br>5V | @V <sub>GS</sub> =<br>10V | @V <sub>GS</sub> =<br>15V | @V <sub>GS</sub> =<br>20V |
| 38 ± 5%                            | 270 ± 7.5%      | 35 ± 7.5%     | -100                     | -100                     | -100                      | -100                      | -100                      |
| 61 ± 5%                            | 330 ± 7.5%      | 30 ± 7.5%     | -100                     | -100                     | -100                      | -100                      | -25                       |
| 84 ± 5%                            | 350 ± 7.5%      | 28 ± 7.5%     | -100                     | -100                     | -100                      | -30                       | -                         |

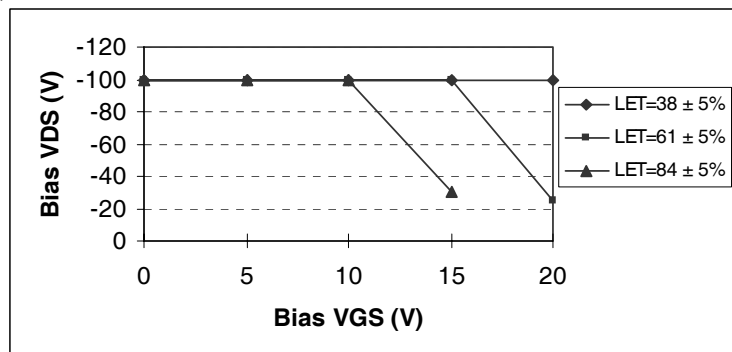

**Fig a. Typical Single Event Effect, Safe Operating Area**

For footnotes refer to the last page

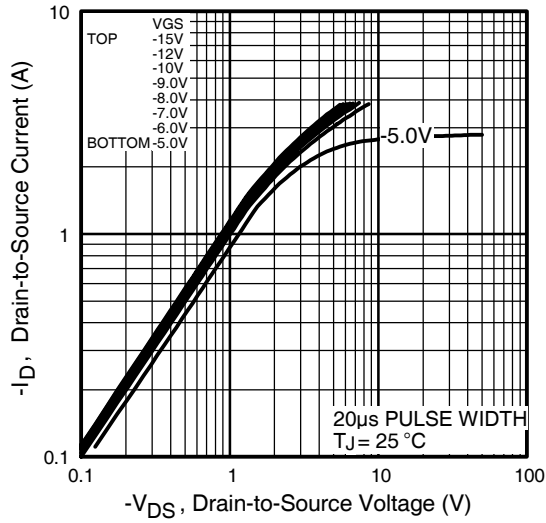

Fig 1. Typical Output Characteristics

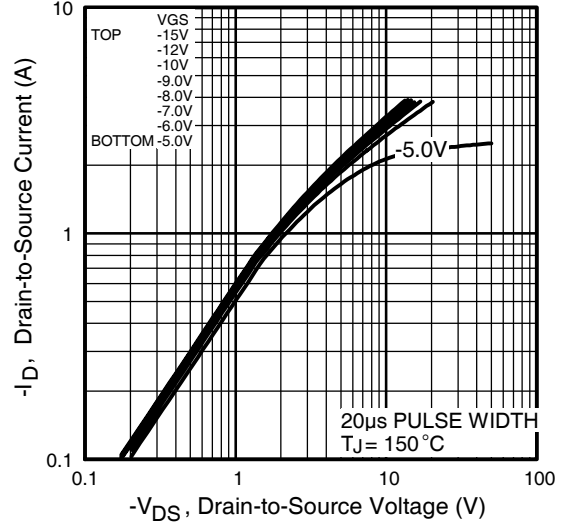

Fig 2. Typical Output Characteristics

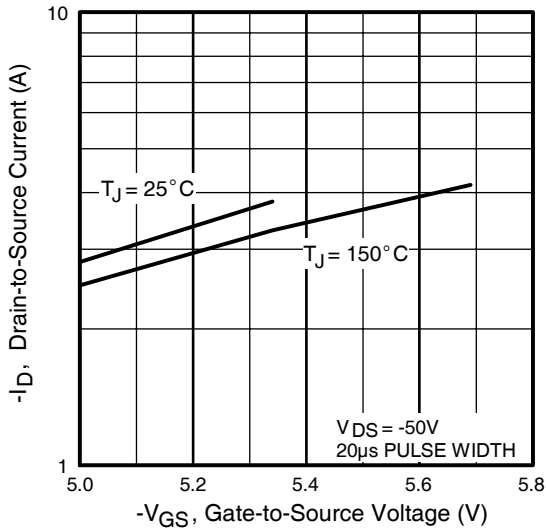

Fig 3. Typical Transfer Characteristics

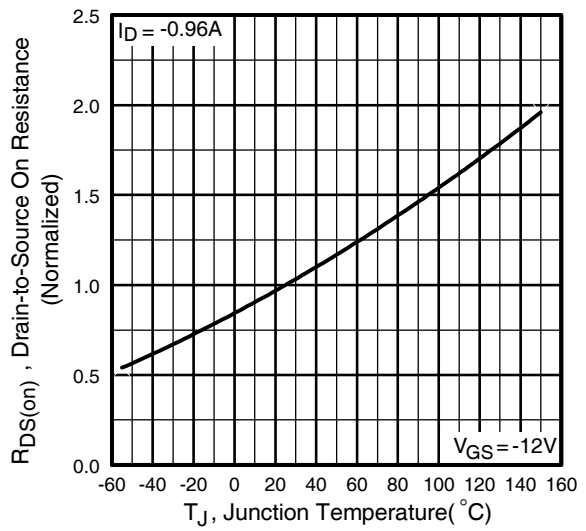
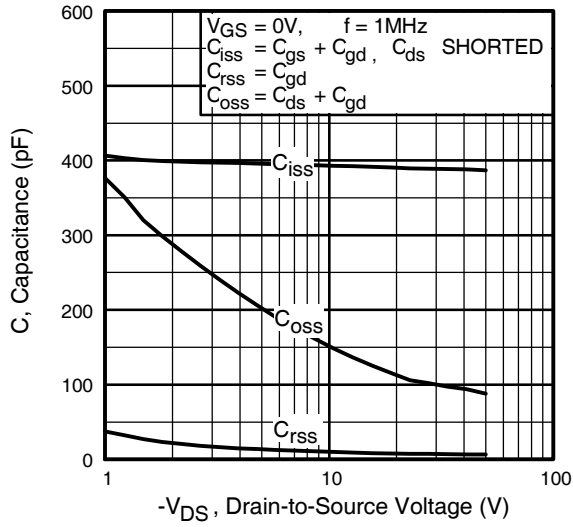
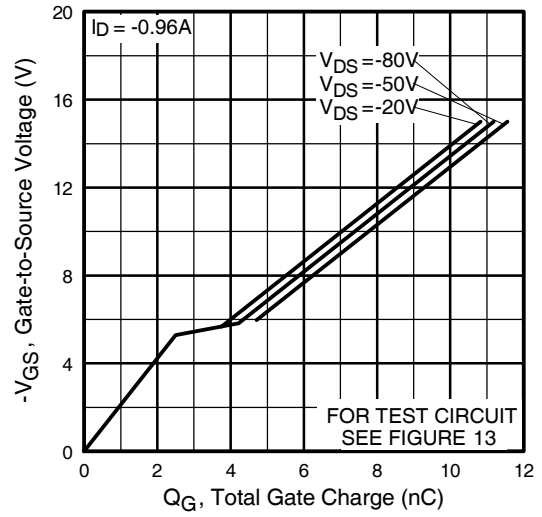

Fig 4. Normalized On-Resistance Vs. Temperature



**Fig 5.** Typical Capacitance Vs. Drain-to-Source Voltage



**Fig 6.** Typical Gate Charge Vs. Gate-to-Source Voltage

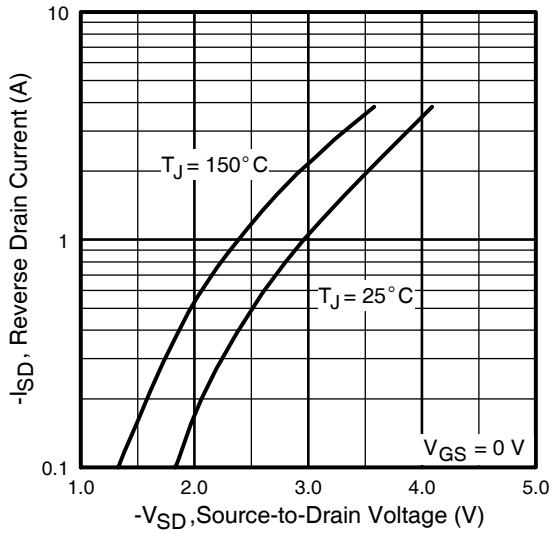

**Fig 7.** Typical Source-Drain Diode Forward Voltage

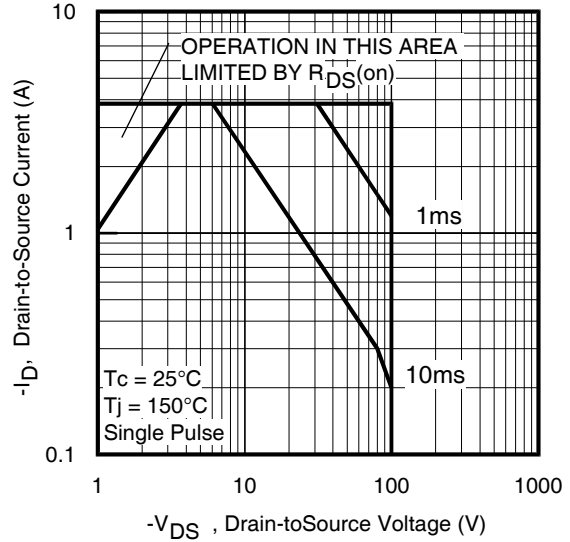

**Fig 8.** Maximum Safe Operating Area

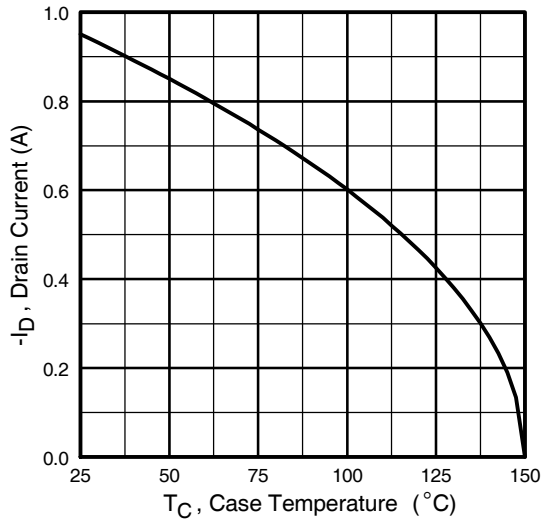

**Fig 9.** Maximum Drain Current Vs. Case Temperature

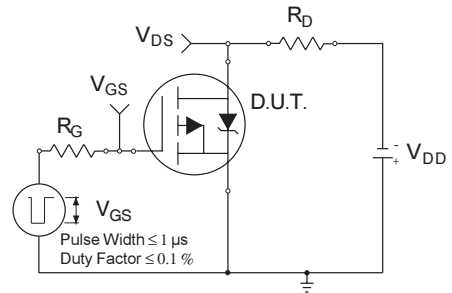

**Fig 10a.** Switching Time Test Circuit

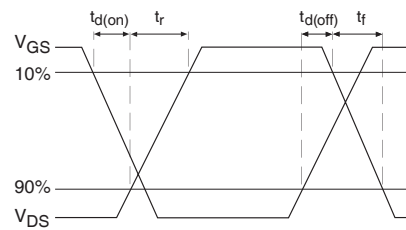

**Fig 10b.** Switching Time Waveforms

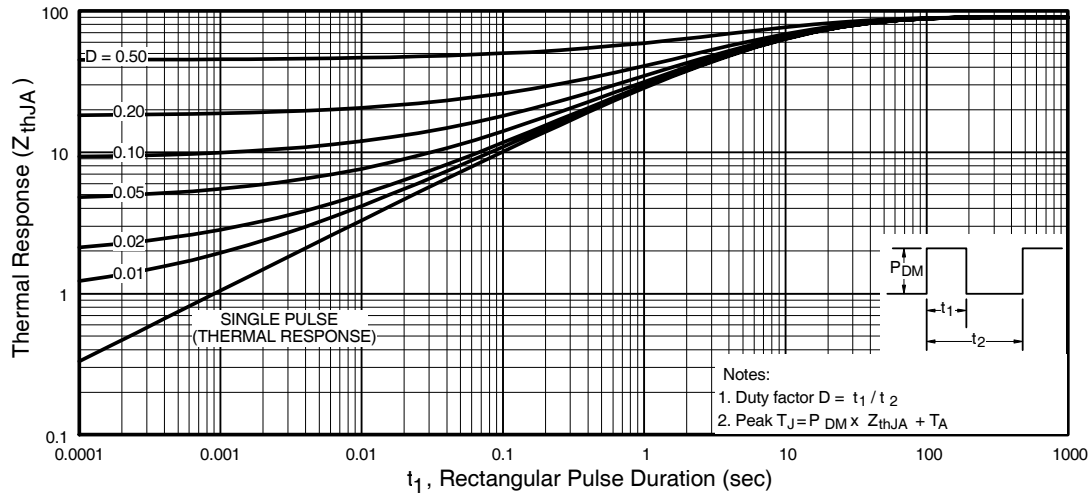

**Fig 11.** Maximum Effective Transient Thermal Impedance, Junction-to-Ambient

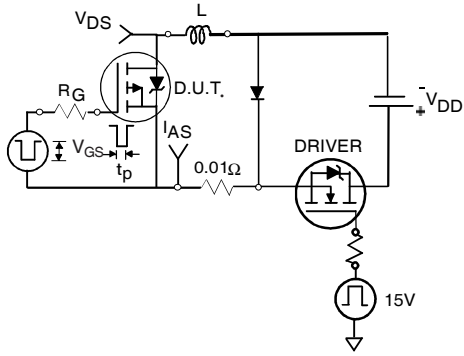

Fig 12a. Unclamped Inductive Test Circuit

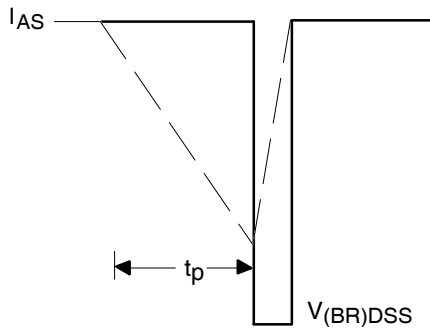

Fig 12b. Unclamped Inductive Waveforms

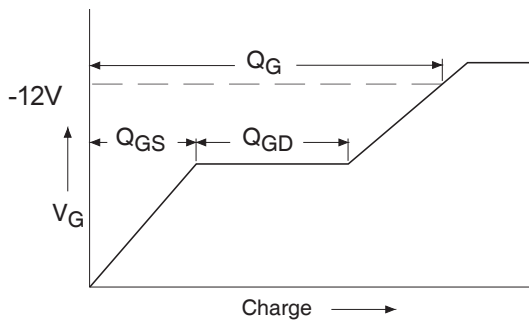

Fig 13a. Basic Gate Charge Waveform

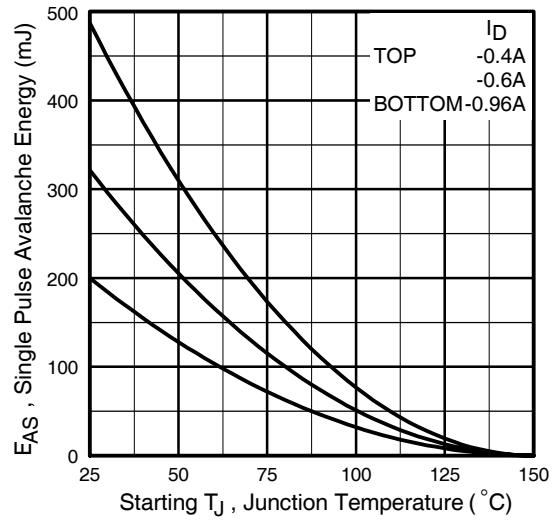

Fig 12c. Maximum Avalanche Energy Vs. Drain Current

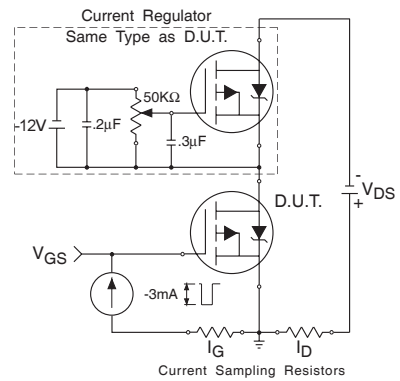
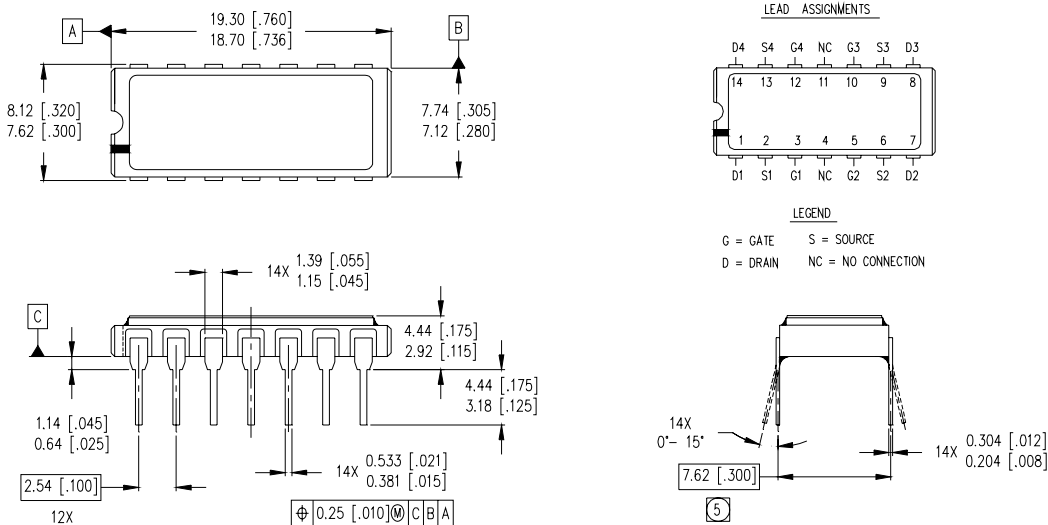

Fig 13b. Gate Charge Test Circuit

**Footnotes:**

- ① Repetitive Rating; Pulse width limited by maximum junction temperature.
- ②  $V_{DD} = -25V$ , starting  $T_J = 25^\circ C$ ,  $L = 430mH$ , Peak  $I_L = -0.96A$ ,  $V_{GS} = -12V$
- ③  $I_{SD} \leq -0.96A$ ,  $di/dt \leq -290A/\mu s$ ,  $V_{DD} \leq -100V$ ,  $T_J \leq 150^\circ C$
- ④ Pulse width  $\leq 300 \mu s$ ; Duty Cycle  $\leq 2\%$
- ⑤ **Total Dose Irradiation with  $V_{GS}$  Bias.**  
-12 volt  $V_{GS}$  applied and  $V_{DS} = 0$  during irradiation per MIL-STD-750, method 1019, condition A
- ⑥ **Total Dose Irradiation with  $V_{DS}$  Bias.**  
-80 volt  $V_{DS}$  applied and  $V_{GS} = 0$  during irradiation per MIL-STD-750, method 1019, condition A

**Case Outline and Dimensions — MO-036AB**



NOTES:

- 1. DIMENSIONING & TOLERANCING PER ASME Y14.5M-1994.
- 2. CONTROLLING DIMENSION: INCH.
- 3. DIMENSIONS ARE SHOWN IN MILLIMETERS [INCHES].
- 4. OUTLINE CONFORMS TO JEDEC OUTLINE MO-036AB.
- ⑤ MEASURED WITH THE LEADS CONSTRAINED TO BE PERPENDICULAR TO DATUM PLANE C.

International  
**IR Rectifier**

AN INFINEON TECHNOLOGIES COMPANY

IR WORLD HEADQUARTERS: 101 N. Sepulveda Blvd., El Segundo, California 90245, USA Tel: (310) 252-7105

IR LEOMINSTER : 205 Crawford St., Leominster, Massachusetts 01453, USA Tel: (978) 534-5776

TAC Fax: (310) 252-7903

Visit us at [www.irf.com](http://www.irf.com) for sales contact information.

Data and specifications subject to change without notice. 07/2015