

FEATURES

- High surge capability
- High on-state current
- High stability and reliability

DESCRIPTION

The TYN210 ---> TYN1010 Family of Silicon Controlled Rectifiers uses a high performance glass passivated technology.

This general purpose Family of Silicon Controlled Rectifiers is designed for power supplies up to 400Hz on resistive or inductive load.

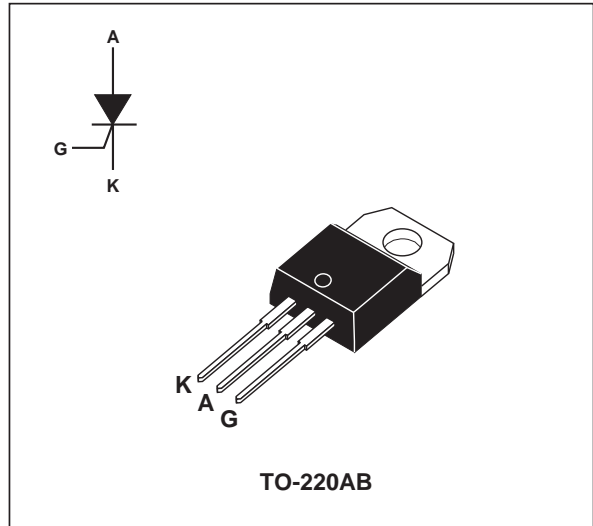

ABSOLUTE RATINGS (limiting values)

Symbol	Parameter	Value	Unit	
$I_{T(RMS)}$	RMS on-state current (180° conduction angle)	$T_c = 100^\circ\text{C}$ 10	A	
$I_{T(AV)}$	Average on-state current (180° conduction angle, single phase circuit)	$T_c = 100^\circ\text{C}$ 6.4	A	
I_{TSM}	Non repetitive surge peak on-state current (T_j initial = 25°C)	$t_p = 8.3\text{ms}$	105	A
		$t_p = 10\text{ms}$	100	
I^2t	I^2t value	$t_p = 10\text{ms}$	50	A ² s
di/dt	Critical rate of rise of on-state current Gate supply: $I_G = 100\text{mA}$ $di_G/dt = 1\text{A}/\mu\text{s}$	50	A/ μs	
T_{stg} T_j	Storage and operating junction temperature range	-40 to +150 -40 to +125	°C	
TI	Maximum lead soldering temperature during 10s at 4.5mm from case	260	°C	

Symbol	Parameter	TYN					Unit
		210	410	610	810	1010	
V_{DRM} V_{RRM}	Repetitive peak off-state voltage $T_j = 125^\circ\text{C}$	200	400	600	800	1000	V

TYN210 ---> TYN1010

THERMAL RESISTANCE

Symbol	Parameter	Value	Unit
Rth (j-a)	Junction to ambient	60	°C/W
Rth (j-c) DC	Junction to case for DC	2.5	°C/W

GATE CHARACTERISTICS (maximum values)

$P_{G(AV)} = 1W$ $P_{GM} = 10W$ ($t_p = 20\mu s$) $I_{FGM} = 4A$ ($t_p = 20\mu s$) $V_{RGM} = 5V$

ELECTRICAL CHARACTERISTICS

Symbol	Test conditions	Value	Unit
I_{GT}	$V_D = 12V$ (DC) $R_L = 33\Omega$	$T_j = 25^\circ C$ MAX.	15 mA
V_{GT}	$V_D = 12V$ (DC) $R_L = 33\Omega$	$T_j = 25^\circ C$ MAX.	1.5 V
V_{GD}	$V_D = V_{DRM}$ $R_L = 3.3k\Omega$	$T_j = 110^\circ C$ MIN.	0.2 V
tgt	$V_D = V_{DRM}$ $I_G = 40mA$ $di_G/dt = 0.5A/\mu s$	$T_j = 25^\circ C$ TYP.	2 μs
I_L	$I_G = 1.2I_{GT}$	$T_j = 25^\circ C$ TYP.	50 mA
I_H	$I_T = 100mA$ Gate open	$T_j = 25^\circ C$ MAX.	30 mA
V_{TM}	$I_{TM} = 20A$ $t_p = 380\mu s$	$T_j = 25^\circ C$ MAX.	1.6 V
I_{DRM} I_{RRM}	V_{DRM} rated V_{RRM} rated	$T_j = 25^\circ C$ MAX.	0.01 mA
		$T_j = 110^\circ C$ MAX.	2 mA
dV/dt	Linear slope up to $V_D = 67\% V_{DRM}$ gate open	$T_j = 110^\circ C$ MIN.	200 V/ μs
tq	$V_D = 67\% V_{DRM}$ $I_{TM} = 20A$ $V_R = 25V$ $di_{TM}/dt = 30 A/\mu s$ $dV_D/dt = 50V/\mu s$	$T_j = 110^\circ C$ TYP.	70 μs

Fig. 1: Maximum average power dissipation versus average on-state current.

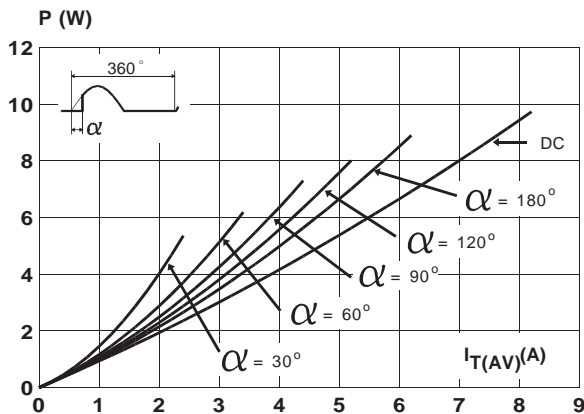

Fig. 2: Correlation between maximum average power dissipation and maximum allowable temperatures (T_{amb} and T_{case}) for different thermal resistances heatsink + contact.

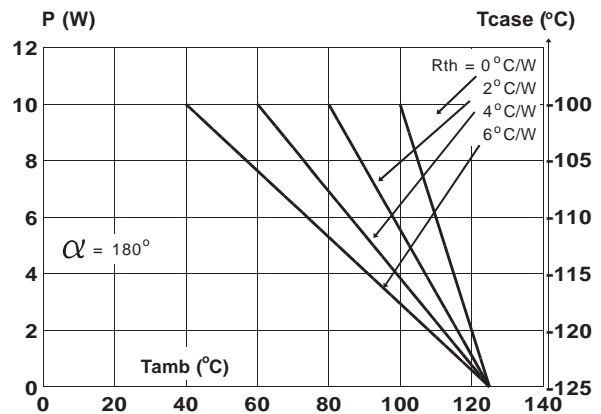

Fig. 3: Average on-state current versus case temperature.

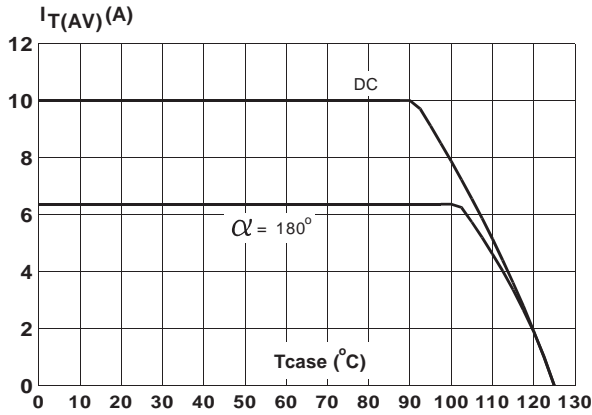

Fig. 4: Relative variation of thermal impedance versus pulse duration.

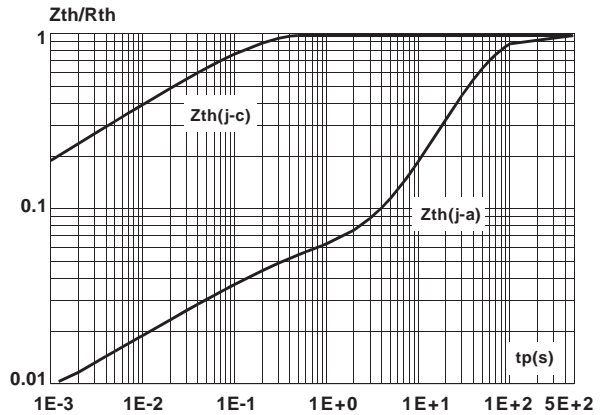

Fig. 5: Relative variation of gate trigger current versus junction temperature.

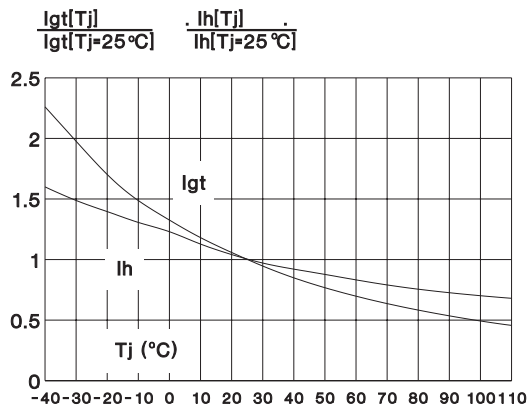

Fig. 6: Non repetitive surge peak on-state current versus number of cycles.

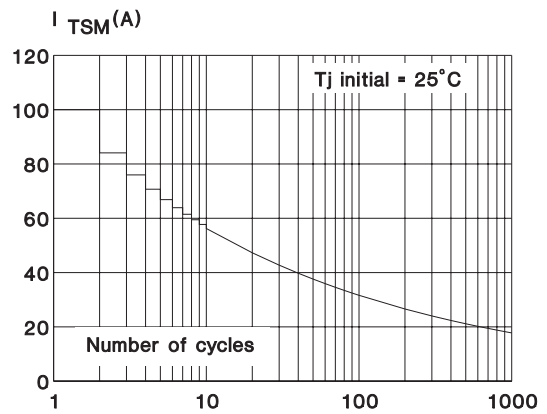

Fig. 7: Non repetitive surge peak on-state current for a sinusoidal pulse with width: $t \leq 10\text{ms}$, and corresponding value of I^2t .

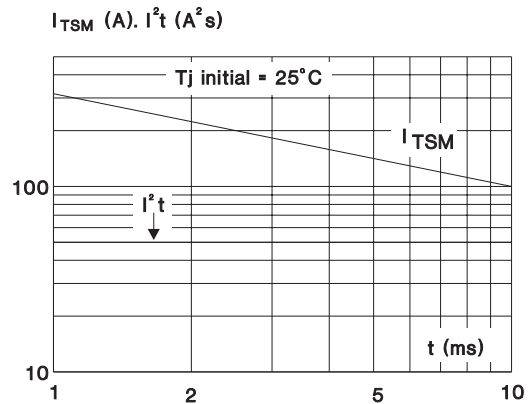
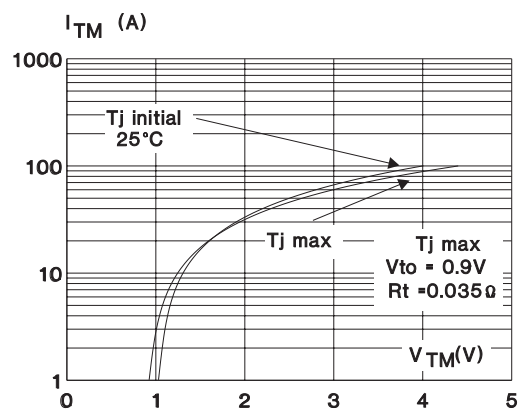

Fig. 8: On-state characteristics (maximum values).



TYN210 ---> TYN1010

PACKAGE MECHANICAL DATA TO-220AB (Plastic)

REF.	DIMENSIONS					
	Millimeters			Inches		
	Min.	Typ.	Max.	Min.	Typ.	Max.
A	15.20		15.90	0.598		0.625
a1		3.75			0.147	
a2	13.00		14.00	0.511		0.551
B	10.00		10.40	0.393		0.409
b1	0.61		0.88	0.024		0.034
b2	1.23		1.32	0.048		0.051
C	4.40		4.60	0.173		0.181
c1	0.49		0.70	0.019		0.027
c2	2.40		2.72	0.094		0.107
e	2.40		2.70	0.094		0.106
F	6.20		6.60	0.244		0.259
I	3.75		3.85	0.147		0.151
I4	15.80	16.40	16.80	0.622	0.646	0.661
L	2.65		2.95	0.104		0.116
I2	1.14		1.70	0.044		0.066
I3	1.14		1.70	0.044		0.066
M		2.60			0.102	

OTHER INFORMATION

Ordering type	Marking	Package	Weight	Base qty	Delivery mode
TYNxx10	TYNxx10	TO-220AB	2.3 g	250	Bulk

- Epoxy meets UL94,V0
- Cooling method: C
- Recommended torque value: 0.8 m.N.
- Maximum torque value: 1 m.N.