

13.56-MHz multi-protocol contactless transceiver IC with SPI and UART serial access

Datasheet - production data

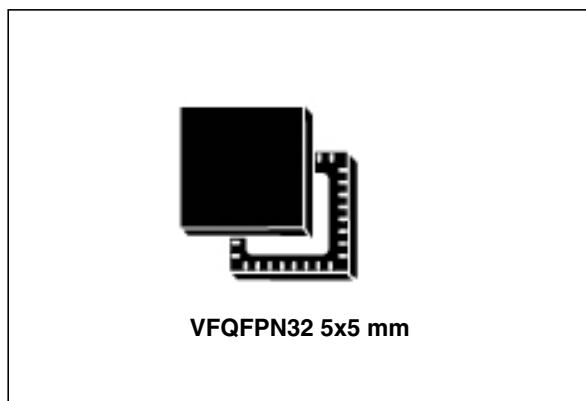

- Communication interfaces with a Host Controller
 - Serial peripheral interface (SPI) Slave interface
 - Universal asynchronous receiver/transmitter (UART)
 - Up to 528-byte command/reception buffer (FIFO)
- 32-lead, 5x5 mm, very thin fine pitch quad flat (VFQFPN) ECOPACK®2 package

Applications

Typical protocols supported:

- ISO/IEC 14443-3 Type A and B tags
- ISO/IEC 15693 tags
- ISO/IEC 18000-3M1 tags
- NFC Forum tags: Types 1, 2, 3 and 4
- ST short-range interface (SRI) tags
- ST long-range interface (LRI) tags
- ST Dual Interface EEPROM

Features

- Operating modes supported:
 - Reader/Writer
- Hardware features
 - Dedicated internal frame controller
 - Highly integrated Analog Front End (AFE) for RF communications
 - Transmission and reception modes
 - Optimized power management
 - Tag Detection mode
- RF communication @13.56 MHz
 - ISO/IEC 14443 Type A and B
 - ISO/IEC 15693
 - ISO/IEC 18092
 - MIFARE® Classic compatible (a) (b)

- a. MIFARE and MIFARE Classic are registered trademarks of NXP B.V. and are used under license.
- b. Parity Framing mode is compatible with MIFARE® Classic requirements. However, access to Authenticated state must be supported by an external secure host which embeds the MIFARE® Classic library.

Contents

- 1 Description 4**
 - 1.1 Block diagram 4
 - 1.2 List of terms 5
- 2 Pin and signal descriptions 6**
- 3 Power management and operating modes 8**
 - 3.1 Operating modes 8
 - 3.2 Startup sequence 9
- 4 Communication protocols 11**
 - 4.1 Universal asynchronous receiver/transmitter (UART) 11
 - 4.2 Serial peripheral interface (SPI) 12
 - 4.2.1 Polling mode 12
 - 4.2.2 Interrupt mode 14
 - 4.3 Error codes 14
 - 4.4 Support of long frames 15
- 5 Commands 16**
 - 5.1 Command format 16
 - 5.2 List of commands 16
 - 5.3 IDN command (0x01) description 17
 - 5.4 Protocol Select command (0x02) description 17
 - 5.5 Send Receive (SendRecv) command (0x04) description 22
 - 5.6 Idle command (0x07) description 27
 - 5.6.1 Idle command parameters 29
 - 5.6.2 Using LFO frequency setting to reduce power consumption 30
 - 5.6.3 Optimizing wake-up conditions 31
 - 5.6.4 Using various techniques to return to Ready state 31
 - 5.6.5 Tag detection calibration procedure 33
 - 5.7 Read Register (RdReg) command (0x08) description 34
 - 5.8 Write Register (WrReg) command (0x09) description 35
 - 5.8.1 Improving RF performance 35
 - 5.8.2 Improving frame reception for ISO/IEC 14443 Type A tags 37

5.8.3	Improving RF reception for ISO/IEC 18092 tags	37
5.9	BaudRate command (0x0A) description	38
5.10	Echo command (0x55) description	38
6	Electrical characteristics	39
6.1	Absolute maximum ratings	39
6.2	DC characteristics	40
6.3	Power consumption characteristics	40
6.4	SPI characteristics	42
6.5	RF characteristics	44
6.6	Oscillator characteristics	45
7	Package mechanical data	46
8	Part numbering	48
Appendix A	Additional Idle command description	49
Appendix B	Example of tag detection calibration process	50
Appendix C	Example of tag detection command using results of tag detection calibration	53
Appendix D	Examples of CR95HF command code to activate NFC Forum and ISO/IEC 15693 tags	54
D.1	ISO/IEC 14443 Type A	54
D.1.1	NFC Forum Tag Type 1 (Topaz)	54
D.1.2	NFC Forum Tag Type 2	56
D.1.3	NFC Forum Tag Type 2 or 4: Using split frames to resolve collisions	57
D.1.4	NFC Forum Tag Type 2	60
D.1.5	NFC Forum Tag Type 4A	63
D.2	ISO/IEC 14443 Type B	66
D.2.1	NFC Forum Tag Type 4B	66
D.3	ISO/IEC 18092	68
D.3.1	NFC Forum Tag Type 3	68
D.4	ISO/IEC 15693	69
D.4.1	ISO/IEC 15693 tag	69
Revision history		71

1 Description

The CR95HF is an integrated transceiver IC for contactless applications.

The CR95HF manages frame coding and decoding in Reader mode for standard applications such as near field communication (NFC), proximity and vicinity standards.

The CR95HF embeds an Analog Front End to provide the 13.56 MHz Air Interface.

The CR95HF supports ISO/IEC 14443 Type A and B, ISO/IEC 15693 (single or double subcarrier) and ISO/IEC 18092 communication protocols.

The CR95HF also supports the detection, reading and writing of NFC Forum Type 1, 2, 3 and 4 tags.

Figure 1. CR95HF application overview

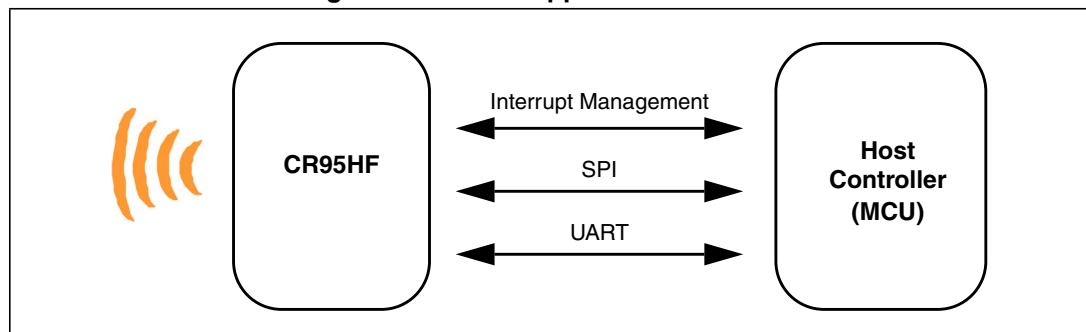

1.1 Block diagram

Figure 2. CR95HF block diagram

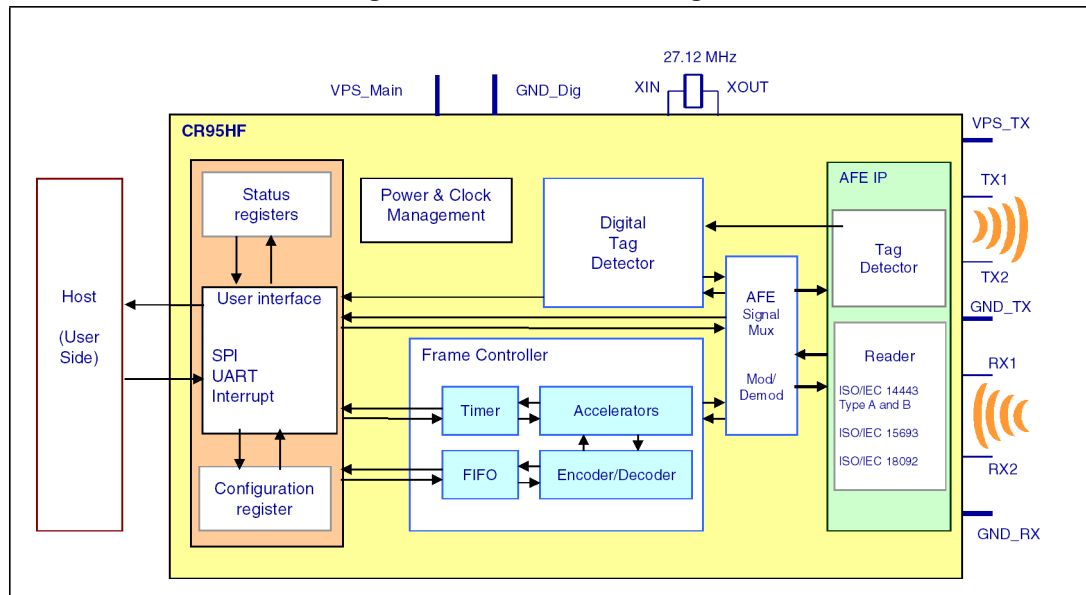

1.2 List of terms

Table 1. List of terms

Term	Meaning
DAC	Digital analog converter
GND	Ground
HFO	High frequency oscillator
LFO	Low frequency oscillator
MCU	Microcontroller unit
NFC	Near Field Communication
RFID	Radio Frequency Identification
RFU	Reserved for future use
SPI	Serial peripheral interface
t_L	Low frequency period
t_{REF}	Reference time
UART	Universal asynchronous receiver-transmitter
WFE	Wait For Event

2 Pin and signal descriptions

Figure 3. CR95HF pinout description

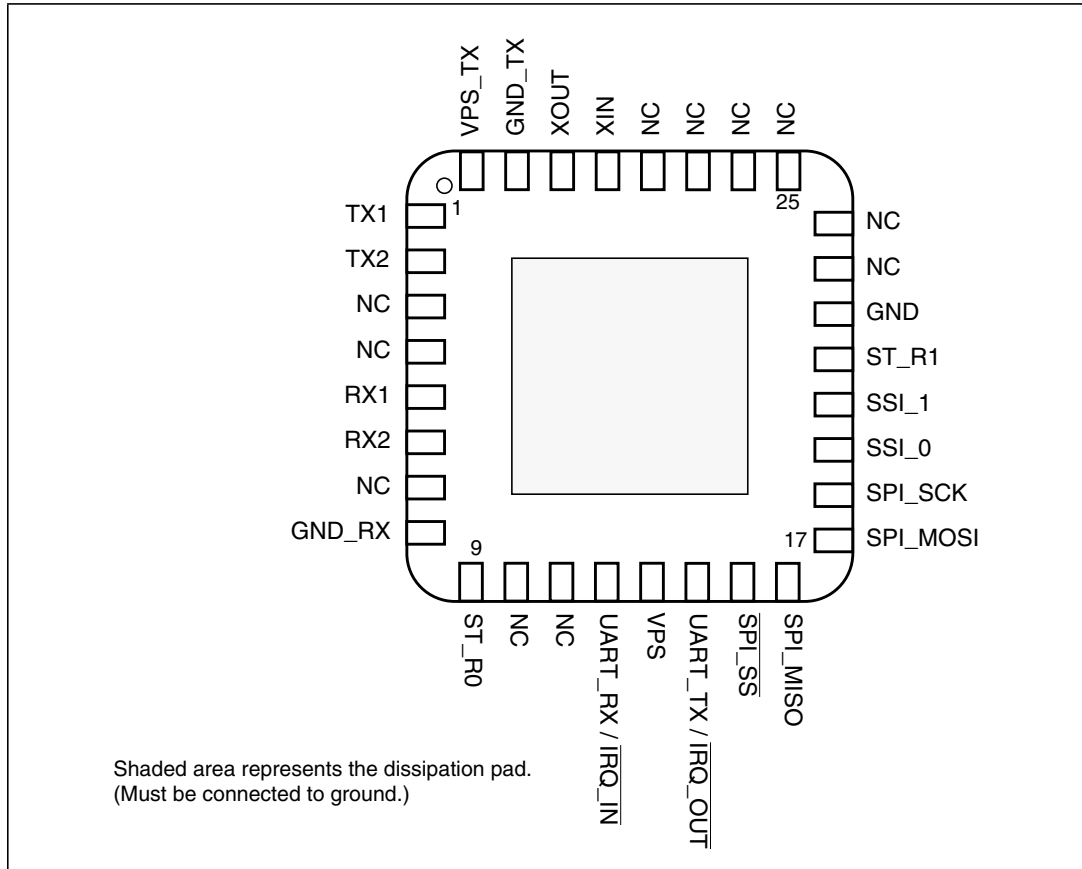

Table 2. CR95HF pin descriptions

Pin	Pin name	Type ⁽¹⁾	Main function	Alternate function
1	TX1	O	Driver output 1	
2	TX2	O	Driver output 2	
3	NC		Not connected	
4	NC		Not connected	
5	RX1	I	Receiver input 1	
6	RX2	I	Receiver input 2	
7	NC		Not connected	
8	GND_RX	P	Ground (analog)	
9	ST_R0	O	ST Reserved ⁽²⁾	
10	NC		Not connected	
11	NC		Not connected	

Table 2. CR95HF pin descriptions (continued)

Pin	Pin name	Type ⁽¹⁾	Main function	Alternate function
12	UART_RX / $\overline{\text{IRQ_IN}}$	I ⁽³⁾	UART receive pin ⁽⁴⁾	Interrupt input
13	VPS	P	Main power supply	
14	UART_TX / $\overline{\text{IRQ_OUT}}$	O ⁽⁵⁾	UART transmit pin	Interrupt output
15	$\overline{\text{SPI_SS}}$	I ⁽⁶⁾	SPI Slave Select (active low)	
16	SPI_MISO	O ⁽⁶⁾	SPI Data, Slave Output	
17	SPI_MOSI	I ⁽⁶⁾	SPI Data, Slave Input ⁽⁶⁾	
18	SPI_SCK	I ⁽⁷⁾	SPI serial clock	
19	SSI_0	I ⁽⁶⁾	Select serial communication interface	
20	SSI_1	I ⁽⁶⁾	Select serial communication interface	
21	ST_R1	I ⁽⁸⁾	ST Reserved	
22	GND	P	Ground (digital)	
23	NC		Not connected	
24	NC		Not connected	
25	NC		Not connected	
26	NC		Not connected	
27	NC		Not connected	
28	NC		Not connected	
29	XIN		Crystal oscillator input	
30	XOUT		Crystal oscillator output	
31	GND_TX	P	Ground (RF drivers)	
32	VPS_TX	P	Power supply (RF drivers)	

1. I: Input, O: Output, and P: Power
2. Must add a capacitor to ground (~1 nF).
3. Pad internally connected to a Very Weak Pull-up to VPS.
4. We recommend connecting this pin to the V_{PS} pin using a 3.3 kOhm pull-up resistor.
5. Pad internally connected to a Weak Pull-up to VPS.
6. Must not be left floating.
7. Pad internally connected to a Weak Pull-down to GND.
8. Pad input in High Impedance. Must be connected to VPS.

3 Power management and operating modes

3.1 Operating modes

The CR95HF has 2 operating modes: Wait for Event (WFE) and Active. In Active mode, the CR95HF communicates actively with a tag or an external host (an MCU, for example). WFE mode includes four low consumption states: Power-up, Hibernate, Sleep and Tag Detector.

The CR95HF can switch from one mode to another.

Table 3. CR95HF operating modes and states

Mode	State	Description
Wait For Event (WFE)	Power-up	This mode is accessible directly after POR. Low level on $\overline{\text{IRQ_IN}}$ pin (longer than 10 μs) is the only wakeup source. LFO (low-frequency oscillator) is running in this state.
	Hibernate	Lowest power consumption state. The CR95HF has to be woken-up in order to communicate. Low level on $\overline{\text{IRQ_IN}}$ pin (longer than 10 μs) is the only wakeup source.
	Sleep	Low power consumption state. Wakeup source is configurable: – Timer – $\overline{\text{IRQ_IN}}$ pin – $\overline{\text{SPI_SS}}$ pin LFO (low-frequency oscillator) is running in this state.
	Tag Detector	Low power consumption state with tag detection. Wakeup source is configurable: – Timer – $\overline{\text{IRQ_IN}}$ pin – $\overline{\text{SPI_SS}}$ pin – Tag detector LFO (low-frequency oscillator) is running in this state.
Active	Ready	In this mode, the RF is OFF and the CR95HF waits for a command (PROTOCOLSELECT, ...) from the external host via the selected serial interface (UART or SPI).
	Reader	The CR95HF can communicate with a tag using the selected protocol or with an external host using the selected serial interface (UART or SPI).

Hibernate, Tag Detector, and Sleep states can only be activated by a command from the external host. As soon as any of these three states are activated, the CR95HF can no longer communicate with the external host. It can only be woken up.

The behavior of the CR95HF in 'Tag Detector' state is defined by the Idle command.

Figure 4. CR95HF initialization and operating state change

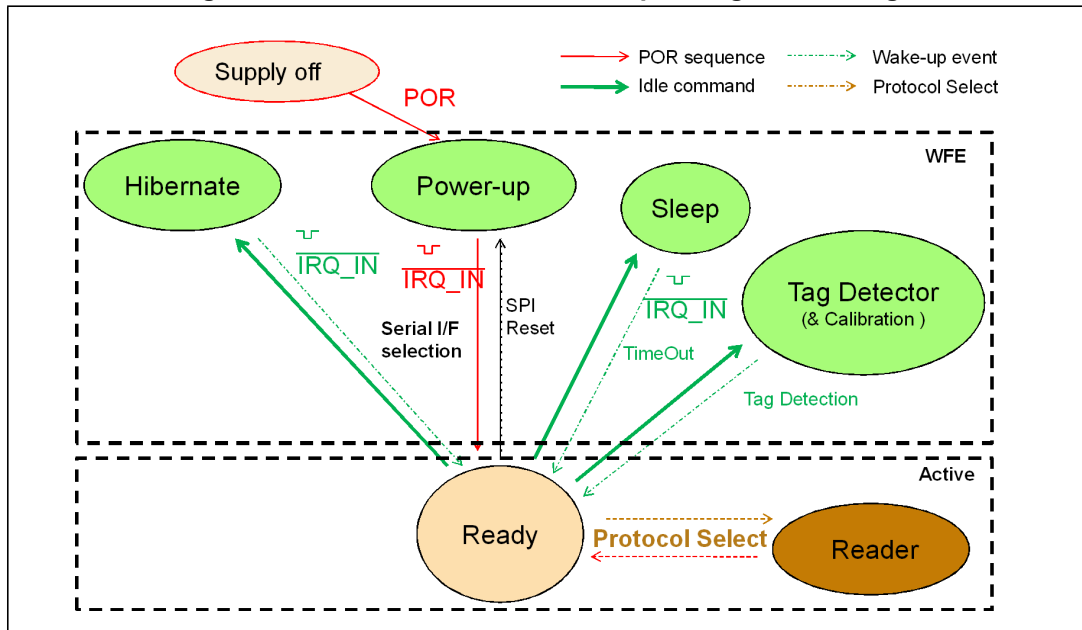

3.2 Startup sequence

After the power supply is established at power-on, the CR95HF waits for a low pulse on the pin $\overline{\text{IRQ_IN}}$ (t_1) before automatically selecting the external interface (SPI or UART) and entering Ready state after a delay (t_3).

Figure 5. Power-up sequence

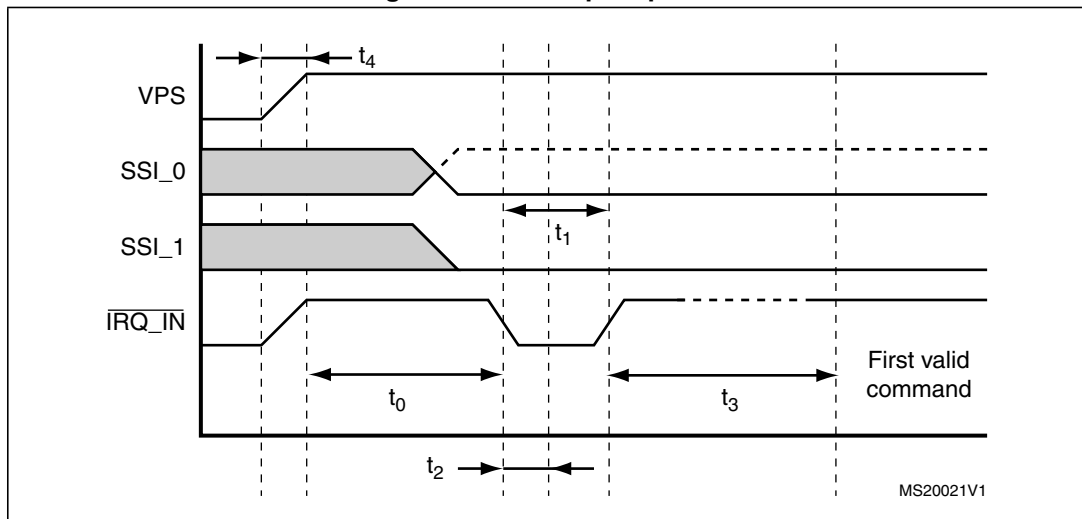

- Note for pin SSI0: - - - SPI selected, — UART selected
- Pin $\overline{\text{IRQ_IN}}$ low level < 0.2 VPS_Main.

Note: When CR95HF leaves WFE mode (from Power-up, Hibernate, Tag Detector, or Sleep) following an $\overline{\text{IRQ_IN}}/\text{RX}$ low level pulse, this pulse is NOT interpreted as the UART start bit character.

Figure 5 shows the power-up sequence for a CR95HF device; where,

- t_0 is the initial wake-up delay 100 μ s (minimum)
- t_1 is the minimum interrupt width 10 μ s (minimum)
- t_2 is the delay for the serial interface selection 250 ns (typical)
- t_3 is the HFO setup time ($t_{SU(HFO)}$) 10 ms (maximum)
- t_4 is the V_{PS} ramp-up time from 0V to V_{PS} 10 ms (max. by design validation)

Note: V_{PS} must be 0V before executing the start-up sequence.

The serial interface is selected after the following falling edge of pin $\overline{TRQ_IN}$ when leaving from POR or Hibernate state.

Table 4 lists the signal configuration used to select the serial communication interface.

Table 4. Select serial communication interface selection table

Pin	Serial interface
SSI_0	UART: 0 SPI: 1
SSI_1	UART: 0 SPI: 0

4 Communication protocols

4.1 Universal asynchronous receiver/transmitter (UART)

The host sends commands to the CR95HF and waits for replies. Polling for readiness is not necessary. The default baud rate is 57600 baud. The maximum allowed baud rate is 2 Mbps.

Figure 6. UART communication

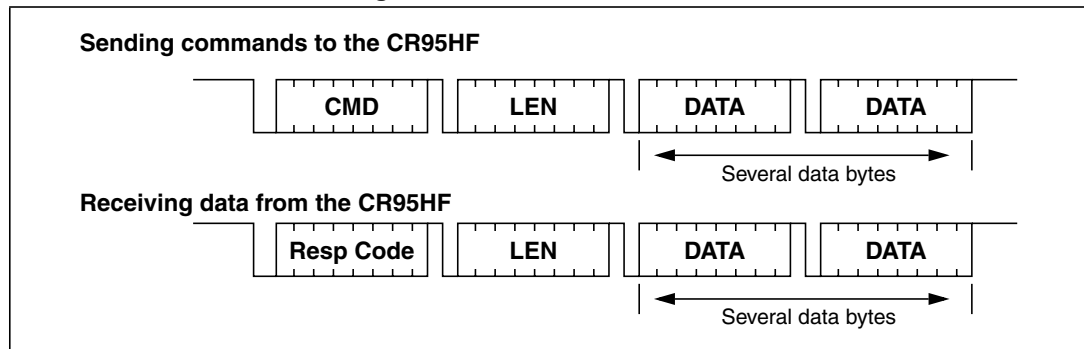

When sending commands, no data must be sent if the LEN field is zero.

When receiving data from the CR95HF, no data will be received if the LEN field is zero.

The formats of send and receive packets are identical.

If an ECHO command is sent, only one byte (0x55) is sent by the host.

Figure 7 shows an example of an ECHO command.

Figure 7. ECHO command and response example

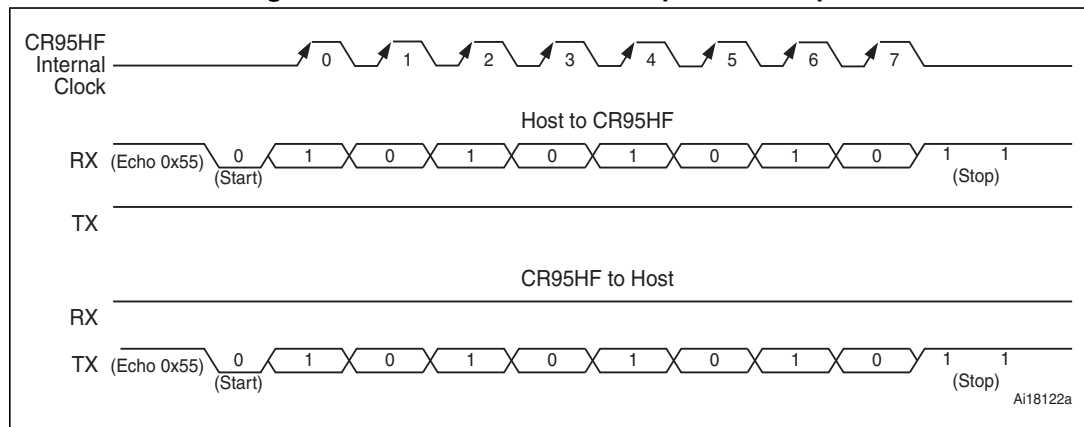

Caution: UART communication is LSB first. Stop bit duration is two Elementary Time Units (ETUs).

- Note:**
- 1 When CR95HF leaves WFE mode (from Power-up, Hibernate, Sleep Detector or Tag Detector) following an $\overline{IRQ_IN}/RX$ low level pulse, this pulse is NOT interpreted as the UART start bit character.
 - 2 If the user loses UART synchronization, it can be recovered by sending an ECHO command until a valid ECHO reply is received. Otherwise, after a maximum of 528 ECHO commands,

CR95HF will reply with an error code meaning its input buffer is full. The user can now restart a UART exchange.

4.2 Serial peripheral interface (SPI)

4.2.1 Polling mode

In order to send commands and receive replies, the application software has to perform 3 steps.

1. Send the command to the CR95HF.
2. Poll the CR95HF until it is ready to transmit the response.
3. Read the response.

The application software should never read data from the CR95HF without being sure that the CR95HF is ready to send the response.

The maximum allowed SPI communication speed is f_{SCK} .

A Control byte is used to specify a communication type and direction:

- 0x00: Send command to the CR95HF
- 0x03: Poll the CR95HF
- 0x02: Read data from the CR95HF
- 0x01: Reset the CR95HF

The $\overline{SPI_SS}$ line is used to select a device on the common SPI bus. The $\overline{SPI_SS}$ pin is active low.

When the $\overline{SPI_SS}$ line is inactive, all data sent by the Master device is ignored and the MISO line remains in High Impedance state.

Figure 8. Sending command to CR95HF

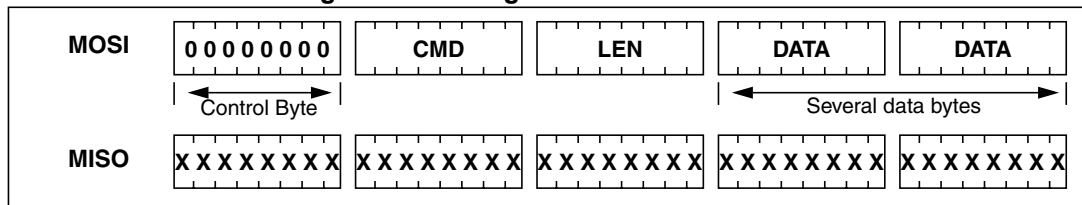

Figure 9. Polling the CR95HF until it is ready

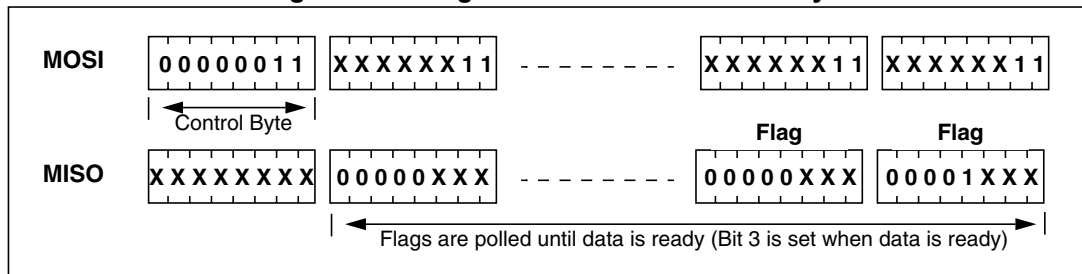
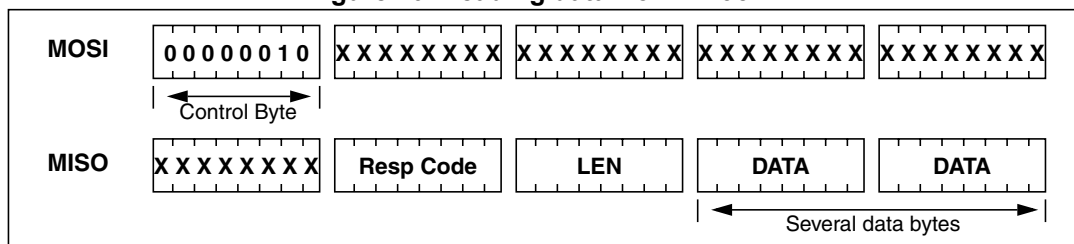

Table 5. Interpretation of flags

Bit	Meaning (Application point of view)
[7:4]	Not significant
3	Data can be read from the CR95HF when set.
2	Data can be sent to the CR95HF when set.
[1:0]	Not significant

Figure 10. Reading data from CR95HF



Data must be sampled at the rising edge of the SCK signal.

'Sending', 'Polling' and 'Reading' commands must be separated by a high level of the SPI_SS line. For example, when the application needs to wait for data from the CR95HF, it asserts the SPI_SS line low and issues a 'Polling' command. Keeping the SPI_SS line low, the Host can read the Flags Waiting bit which indicates that the CR95HF can be read. Then, the application has to assert the SPI_SS line high to finish the polling command. The Host asserts the SPI_SS line low and issues a 'Reading' command to read data. When all data is read, the application asserts the SPI_SS line high.

The application is not obliged to keep reading Flags using the Polling command until the CR95HF is ready in one command. It can issue as many 'Polling' commands as necessary. For example, the application asserts SPI_SS low, issues 'Polling' commands and reads Flags. If the CR95HF is not ready, the application can assert SPI_SS high and continue its algorithm (measuring temperature, communication with something else). Then, the application can assert SPI_SS low again and again issue 'Polling' commands, and so on, as many times as necessary, until the CR95HF is ready.

Note that at the beginning of communication, the application does not need to check flags to start transmission. The CR95HF is assumed to be ready to receive a command from the application.

Figure 11. Reset the CR95HF

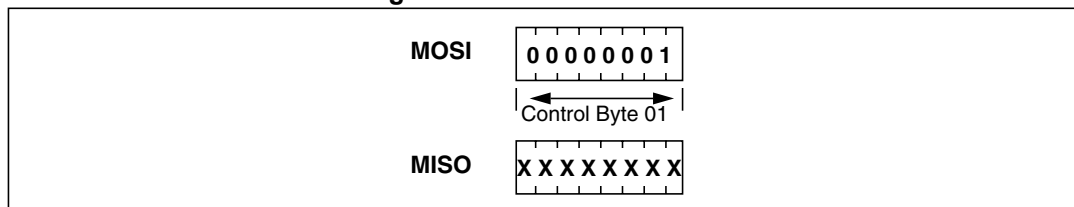

To reset the CR95HF using the SPI, the application sends the SPI Reset command (Control Byte 01, see [Figure 11](#)) which starts the internal controller reset process and puts the CR95HF into Power-up state. The CR95HF will wake up when pin IRQ_IN goes low. The CR95HF reset process only starts when the SPI_SS pin returns to high level.

Caution: SPI communication is MSB first.

4.2.2 Interrupt mode

When the CR95HF is configured to use the SPI serial interface, pin $\overline{\text{IRQ_OUT}}$ is used to give additional information to user. When the CR95HF is ready to send back a reply, it sends an Interrupt Request by setting a low level on pin $\overline{\text{IRQ_OUT}}$, which remains low until the host reads the data.

The application can use the Interrupt mode to skip the polling stage.

Caution: SPI communication is MSB first.

4.3 Error codes

Table 6. Possible error codes and their meaning

Code	Name	Meaning
0x80	EFrameRecvOK	Frame correctly received (additionally see CRC/Parity information)
0x85	EUserStop	Stopped by user (used only in Card mode)
0x86	ECommError	Hardware communication error
0x87	EFrameWaitTOut	Frame wait time out (no valid reception)
0x88	EInvalidSof	Invalid SOF
0x89	EBufOverflow	Too many bytes received and data still arriving
0x8A	E FramingError	if start bit = 1 or stop bit = 0
0x8B	EEgtError	EGT time out
0x8C	EInvalidLen	Valid for ISO/IEC 18092, if Length <3
0x8D	ECrcError	CRC error, Valid only for ISO/IEC 18092
0x8E	ERecvLost	When reception is lost without EOF received (or subcarrier was lost)
0x8F	ENoField	When Listen command detects the absence of external field
0x90	EUnintByte	Residual bits in last byte. Useful for ACK/NAK reception of ISO/IEC 14443 Type A.

4.4 Support of long frames

In Reader mode it is possible to receive up to 528 bytes of frame data from VICC and Type-B cards and up to 256 bytes of frame data from Type-A cards. In this case, the device sends a reply to the external MCU in the following format:

<ResultCode> + <Len> + <N bytes of data>

Table 7. Format of ResultCode

Bit	Meaning	
7	Always 1	
6	Bit 9 of Length	See examples and explanation below
5	Bit 8 of Length	
4	If set, there are residual bits in the last byte. Applicable only for Type-A protocol.	
3:0	Always 0	

Figure 12. Long frame format

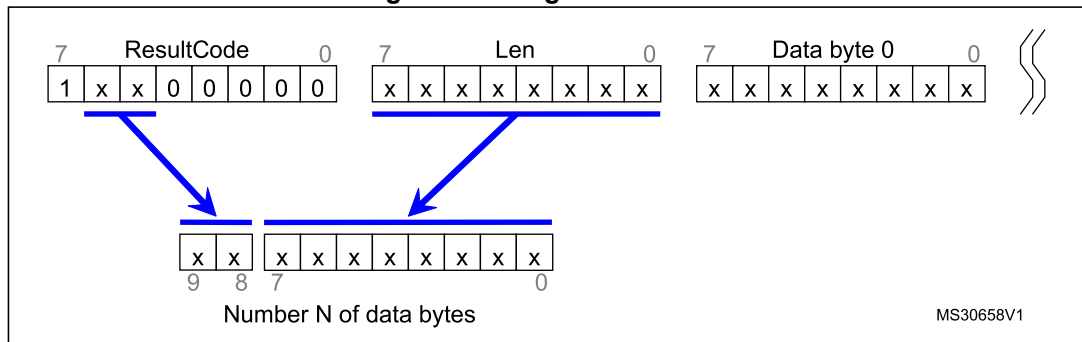

The number of databytes is 10-bit long.

Table 8. Examples of ResultCode: Len pairs

ResultCode	Len	Length of data
0x80	0x00	0
0x80	0x01	1
0x80	0xFF	255
0xA0	0x00	256
0xA0	0x01	257
0xA0	0xFF	511
0xC0	0x00	512
0xC0	0x01	513

5 Commands

5.1 Command format

- The frame from the Host to the CR95HF has the following format:
 <CMD><Len><Data>
- The frame from the CR95HF to Host has the following format:
 <RespCode><Len><Data>

These two formats are available either in both UART and SPI modes.

Fields <Cmd>, <RespCode> and <Len> are always 1 byte long. <Data> can be from 0 to 253 bytes.

Note: The ECHO command is an exception as it has only one byte (0x55).

The following symbols correspond to:

- >>> Frame sent by the Host to CR95HF
- <<< Frame sent by the CR95HF to the Host

5.2 List of commands

Table 9 summarizes the available commands.

Table 9. List of CR95HF commands

Code	Command	Description
0x01	IDN	Requests short information about the CR95HF and its revision.
0x02	PROTOCOLSELECT	Selects the RF communication protocol and specifies certain protocol-related parameters.
0x04	SendRecv	Sends data using the previously selected protocol and receives the tag response.
0x07	IDLE	Switches the CR95HF into a low consumption Wait for Event (WFE) mode (Power-up, Hibernate, Sleep or Tag Detection), specifies the authorized wake-up sources and waits for an event to exit to Ready state.
0x08	RDREG	Reads Wake-up event register or the Analog Register Configuration (ARC_B) register.
0x09	WRREG	Writes Analog Register Configuration (ARC_B) register or writes index of ARC_B register address. Writes the Timer Window (TimerW) value dedicated to ISO/IEC 14443 Type A tags. Writes the AutoDetect Filter enable register dedicated to ISO/IEC 18092 tags.
0x0A	BaudRate	Sets the UART baud rate.
0x55	Echo	CR95HF returns an ECHO response (0x55).
Other codes		ST Reserved

5.3 IDN command (0x01) description

The IDN command (0x01) gives brief information about the CR95HF and its revision.

Table 10. IDN command description

Direction	Data	Comments	Example
Host to CR95HF	0x01	Command code	>>>0x0100
	0x00	Length of data	
CR95HF to Host	0x00	Result code	<<<0x000F4E4643204653324A41535434002ACE In this example, <<<0x4E4643204653324A4153543400 : 'NFC FS2JAST4', #4 (Last Character of NFC FS2JAST4 means ROM code revision 4.) 0x2ACE: CRC of ROM (real CRC may differ from this example)
	<Len>	Length of data	
	<Device ID>	Data in ASCII format (13 bytes)	
	<ROM CRC>	CRC calculated for ROM content (2 bytes)	

It takes approximately 6 ms to calculate the CRC for the entire ROM. The application must allow sufficient time for waiting for a response for this command.

5.4 Protocol Select command (0x02) description

This command selects the RF communication protocol and prepares the CR95HF for communication with a contactless tag.

Table 11. PROTOCOLSELECT command description

Direction	Data	Comments	Example
Host to CR95HF	0x02	Command code	See Table 12: List of <Parameters> values for the ProtocolSelect command for different protocols on page 18 for a detailed example.
	<Len>	Length of data	
	<Protocol>	Protocol codes: 00: Field OFF 01: ISO/IEC 15693 02: ISO/IEC 14443-A 03: ISO/IEC 14443-B 04: ISO/IEC 18092 /NFC Forum Tag Type 3	
	<Parameters>	Each protocol has a different set of parameters. See Table 12 .	
CR95HF to Host	0x00	Result code	<<<0x0000
	0x00	Length of data	Protocol is successfully selected
CR95HF to Host	0x82	Error code	<<<0x8200
	0x00	Length of data	Invalid command length

Table 11. PROTOCOLSELECT command description (continued)

Direction	Data	Comments	Example
CR95HF to Host	0x83	Error code	<<<0x8300
	0x00	Length of data	Invalid protocol

Note that there is no 'Field ON' command. When the application selects an RF communication protocol, the field automatically switches ON .

When the application selects a protocol, the CR95HF performs all necessary settings: it will choose the appropriate reception and transmission chains, switch ON or OFF the RF field and connect the antenna accordingly.

Different protocols have different sets of parameters. Values for the <Parameters> field are listed in [Table 12](#).

Table 12. List of <Parameters> values for the PROTOCOLSELECT command for different protocols

Protocol	Code	Parameters			Examples of commands
		Byte	Bit	Function	
Field OFF	0x00	0	7:0	RFU	>>>0x02020000
ISO/IEC 15693	0x01	0	7:6	RFU	H 100 S: >>>0x02 02 01 01 H 100 D: >>>0x02 02 01 03 H 10 S: >>>0x02 02 01 05 H 10 D: >>>0x02 02 01 07 L 100 S: >>>0x02 02 01 21 L 100 D: >>>0x02 02 01 23 L 10 S: >>>0x02 02 01 25 L 10 D: >>>0x02 02 01 27 In these examples, the CRC is automatically appended.
			5:4	00: 26 Kbps (H) 01: 52 Kbps 10: 6 Kbps (L) 11: RFU	
			3	0: Respect 312-µs delay 1: Wait for SOF ⁽¹⁾	
			2	0: 100% modulation (100) 1: 10% modulation (10)	
			1	0: Single subcarrier (S) 1: Dual subcarrier (D)	
			0	Append CRC if set to '1'. ⁽¹⁾	

Table 12. List of <Parameters> values for the PROTOCOLSELECT command for different protocols (continued)

Protocol	Code	Parameters			Examples of commands	
		Byte	Bit	Function		
ISO/IEC 14443 Type A	0x02	0	7:6	Transmission data rate 00: 106 Kbps 01: 212 Kbps ⁽²⁾ 10: 424 Kbps 11: RFU	>>>0x02020200: ISO/IEC 14443 Type A tag, 106 Kbps transmission and reception rates, Time interval 86/90 Note that REQA, WUPA, Select20 and Select70 commands use a fixed interval of 86/90 μs between a request and its reply. Other commands use a variable interval with fixed granularity. Refer to the ISO/IEC 14443 standard for more details.	
NFC Forum Tag Type 1 (Topaz)			5:4	Reception data rate 00: 106 Kbps 01: 212 Kbps ⁽²⁾ 10: 424 Kbps 11: RFU		
NFC Forum Tag Type 2		3	RFU			
		2:0	RFU			
NFC Forum Tag Type 4A		1	7:0	PP		These 5 bytes are optional. The default PP:MM:DD value is 0 (corresponds to FDT 86/90μs) . For other values, FDT = (2 ^{PP})*(MM+1)*(DD+128) *32/13.56 μs
		2	7:0	MM		
		3	7:0	DD (optional to PP:MM)		
		4	7:0	ST Reserved (Optional)		
		5	7:0	ST Reserved (Optional)		

Table 12. List of <Parameters> values for the PROTOCOLSELECT command for different protocols (continued)

Protocol	Code	Parameters			Examples of commands	
		Byte	Bit	Function		
ISO/IEC 14443 Type B NFC Forum Tag Type 4B	0x03	0	7:6	Transmission data rate 00: 106 Kbps 01: 212 Kbps 10: 424 Kbps 11: 848 Kbps	>>>0x02020301: ISO/IEC 14443 Type B tag with CRC appended	
			5:4	Reception data rate 00: 106 Kbps 01: 212 Kbps 10: 424 Kbps 11: 848 Kbps		
			3:1	RFU		
			0	Append CRC if set to '1'. (1)		
		1	7:0	PP	These 9 bytes are optional. Default value of PP:MM:DD is 0 and corresponds to FWT ~302µs. FWT = $(2^{PP}) * (MM+1) * (DD+128) * 32 / 13.56 \mu s$	
		2	7:0	MM		
		3	7:0	DD (optional to PP:MM)		
		5:4	7:0	TTTT (Optional)		TR0 = TTTT/FC (LSB first), default 1023 = 0x3FF
		6	7:0	YY (Optional)		PCD Min TR1 (Min_TR1 = $8 * XX / f_s$), default = 0
		7	7:0	ZZ (Optional)		PCD Max TR1 (Max_TR1 = $8 * ZZ / f_s$), default = 26 = 0x1A
8	7:0	ST Reserved (Optional)				
9	7:0	ST Reserved (Optional)				

Table 12. List of <Parameters> values for the PROTOCOLSELECT command for different protocols (continued)

Protocol	Code	Parameters			Examples of commands
		Byte	Bit	Function	
ISO/IEC 18092 NFC Forum Tag Type 3	0x04	0	7:6	Transmission data rate 00: RFU 01: 212 Kbps 10: 424 Kbps 11: RFU	>>>0x02020451: ISO/IEC18092 tag, 212 Kbps transmission and reception rates with CRC appended. Parameter 'Slot counter' is not mandatory. If it is not present, it is assumed that SlotCounter = 0x00 (1 slot) For device detection commands, byte 1 bit 4 must be set to '0'. In this case, the FWT is 2.4 ms for the 1st slot and 1.2 ms more for each following slot, if slot counter is specified. If slot counter = 0x10, the CR95HF does not respect reply timings, but polls incoming data and searches a valid response during ~8.4 ms.
			5:4	Reception data rate 00: RFU 01: 212 Kbps 10: 424 Kbps 11: RFU	
			3:1	RFU	
			0	Append CRC if set to '1'. (1)	
		1	7:5	RFU	These 3 bytes are optional. Default value PP:MM:DD: is 0 and corresponds to RWT ~302µs. RWT = (2^PP)*(MM+1)* (DD+128)*32/13.56µs
			4	0: FWT = 2.4 ms 1: FWT is specified by PP:MM bits	
			3:0	Slot counter 0: 1 slot 1: 2 slots ... F: 16 slots	
			2	7:0	
		3	7:0	MM	
		4	7:0	DD (optional to PP:MM)	

1. It is recommended to set this bit to '1'.
2. Not characterized.

5.5 Send Receive (SendRecv) command (0x04) description

This command sends data to a contactless tag and receives its reply.

Before sending this command, the Host must first send the PROTOCOLSELECT command to select an RF communication protocol.

If the tag response was received and decoded correctly, the <Data> field can contain additional information which is protocol-specific. This is explained in [Table 14](#).

Table 13. SENDRECV command description

Direction	Data	Comments	Example
Host to CR95HF	0x04	Command code	See Table 14 and Table 18 for detailed examples.
	<Len>	Length of data	
	<Data>	Data to be sent	
CR95HF to Host	0x80	Result code	<<<0x800F5077FE01B3000000000071718EBA00
	<Len>	Length of data	The tag response is decoded. This is an example of an ISO/IEC 14443 ATQB response (Answer to Request Type B)
	<Data>	Data received. Interpretation depends on protocol	
CR95HF to Host	0x90	Result code	<<<0x90040x240000 (exception for 4-bit frames where 'x' represents ACK or NAK value)
	<Len>	Length of data	
	ACK or NAK	ISO 14443-A ACK or NAK detection	90: Result code for "non-integer number of bytes are received" 04: total length of data 0A or 00: Data 24: "2" means no CRC, "4" means 4 significant bits in Data byte. 00 00: No collision in response
	xx yy zz	3-byte response flag analysis	Example ACK <<< 0x90040A240000 Example NAK <<< 0x900400240000 xx: Error type and number of significant bits in first data byte yy: First byte collision zz: First bit collision ⁽¹⁾
CR95HF to Host	X0 + <Len> + Data (See Support of long frames on page 15)		
CR95HF to Host	0x86	Error code	<<<0x8600 Communication error
	0x00	Length of data	
CR95HF to Host	0x87	Error code	<<<0x8700 Frame wait time out or no tag
	0x00	Length of data	

Table 13. SENDRECV command description (continued)

Direction	Data	Comments	Example
CR95HF to Host	0x88	Error code	<<<0x8800 Invalid SOF
	0x00	Length of data	
CR95HF to Host	0x89	Error code	<<<0x8900 Receive buffer overflow (too many bytes received)
	0x00	Length of data	
CR95HF to Host	0x8A	Error code	<<<0x8A00 Framing error (start bit = 0, stop bit = 1)
	0x00	Length of data	
CR95HF to Host	0x8B	Error code	<<<0x8B00 EGT time out (for ISO/IEC 14443-B)
	0x00	Length of data	
CR95HF to Host	0x8C	Error code	<<<0x8C00 Invalid length. Used in NFC Forum Tag Type 3, when field Length < 3
	0x00	Length of data	
CR95HF to Host	0x8D	Error code	<<<0x8D00 CRC error (Used in NFC Forum Tag Type 3 protocol)
	0x00	Length of data	
CR95HF to Host	0x8E	Error code	<<<0x8E00 Reception lost without EOF received
	0x00	Length of data	

1. See [Table 14](#) for details.

[Table 14](#) gives examples of communication between the CR95HF and a contactless tag. The CR95HF receives a SendRecv command (>>> 0x04...) from the host and returns its response to the host (<<< 0x80...). [Table 14](#) provides more details on the CR95HF response format.

Table 14. List of <Data> Send values for the SENDRECV command for different protocols

Protocol	Explanation	Command example	Comments
ISO/IEC 15693	Send example	04 03 022000	Example of an Inventory command using different protocol configuration: Uplink: 100% ASK, 1/4 coding Downlink: High data rate, Single sub-carrier >>> 0x0403260100 (Inventory - 1 slot) <<< 0x800D0000CDE0406CD62902E0057900 If length of data is '0', only the EOF will be sent. This can be used for an anti-collision procedure.
	Command code		
	Length of entire data field		
	Data		

Table 14. List of <Data> Send values for the SENDRECV command for different protocols (continued)

Protocol	Explanation	Command example		Comments
ISO/IEC 14443 Type A NFC Forum Tag Type 4A NFC Forum Tag Type 1 (Topaz) NFC Forum Tag Type 2	Send example	04	07	9370800 28 F8C8E Example of an NFC Forum Type 2 request sequence: >>>0x04022607 (REQA) <<<0x800544002800 (ATQA) >>>0x0403932008 (Anti-collision CL1) <<<0x80088804A8D5F1280000 (UID CL1)... Example of an NFC Forum Type 1 (Topaz) request sequence: >>>0x04022607 (REQA) <<<0x8005000C280000 (ATQ0 ATQ1) >>>0x0408780000000000000A8 (RID) <<<0x800B11486E567A003E450800 00 (Header0 Header1 UID0 UID 1 UID2 UID3 CRC0 CRC1Significant bits indexColbyte IndexColbit) Application SW must specify how many bits to send in the last byte. If flag SplitFrame is set, CR95HF will expect 8 - <significant bit count> bits in the 1 st byte during reception. In this case, the first byte received is padded with zeros in lsb to complete the byte, while the last byte received is padded with zeros in msb. Example of an anti-collision command /response in ISO/IEC 14443_A communication using a Split frame: ⁽¹⁾ >>> 0x0403932008 (Anticol) <<< 0x800888047B75B7B80204 (Collision Detected B8) >>> 0x0406934588040B45 (Anticol Split frame request 45) <<< 0x80064074B3230000 (Spilt frame Answer 23) This command is useful for anti-collision.
	Command code			
	Length of entire data field			
	Data			
ISO/IEC 14443 Type B NFC Forum Tag Type 4B	Send example	04	03	050000 Example of an NFC Forum Type 4B request sequence: >>>0x0403050000 (REQB) <<<0x800F5077FE01B30000000000 71718EBA00 (ATQB)
	Command code			
	Length of entire data field			
	Data			

Table 14. List of <Data> Send values for the SENDRECV command for different protocols (continued)

Protocol	Explanation	Command example			Comments
ISO/IEC 18092	Send example	04	05	00FFFF0000	Example of an ISO/IEC 18092 / NFC Forum Type 3 request sequence: >>>0x040500FFFF0000 (REQC) <<<0x801201010102148E0DB413100B4B428485D0FF00 (ATQC)
	Command code				
NFC Forum Tag Type 3	Length of entire data field				
	Data				

- For more information on using split frames, refer to [Appendix D on page 54](#).
- If Parity Framing mode is used (Bit 4 of transmission flag byte is set to '1'), then the parity bit must be coded inside the data for each byte to be sent using the send/receive command in Transmit mode, and is not decoded by the CR95HF in Receive mode. In Receive mode, each data byte is accompanied by an additional byte which encodes the parity: <data byte> <parity byte> <data byte > ...
Examples of data received by send / receive in Parity Framing mode:
80 05 32 80 34 00 00
meaning: if the CR95HF received 2 data bytes:
0x32 with parity = '1' (0x80) and 0x34 with parity = '0' (0x0) in Parity Framing mode. For more details, see [NFC Forum Tag Type 2 on page 60](#).
The Parity Framing mode is compatible with MIFARE® Classic requirements. However, access to Authenticated state must be supported by the external secure host which embeds the MIFARE® Classic library.

Figure 13. Data transfer (in both command and response) when Parity Framing mode is enabled

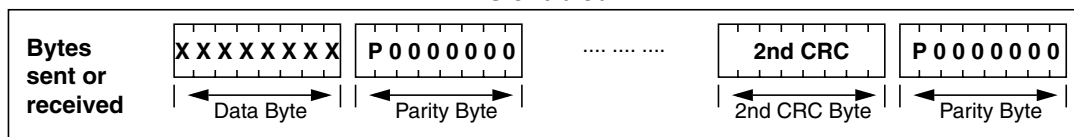

Table 15. List of <Data> Response values for the SENDRECV command for different protocols

Protocol	Explanation	Response example			Comments
ISO/IEC 15693	Response example	80	08	0000000000	This is a response to Read Single Block command for ISO/IEC 15693 TAG. Actual TAG response is <<<0x000000000077CF, other fields are added by the CR95HF.
	Result code			77CF	
	Length of entire data field			00	
	Data received from tag				
	Original (received) value of CRC				
	[7:2]: RFU 1: CRC error if set 0: Collision is detected if set				

Table 15. List of <Data> Response values for the SENDRECV command for different protocols (continued)

Protocol	Explanation	Response example						Comments
ISO/IEC 14443 Type A NFC Forum Tag Type 4A NFC Forum Tag Type 1 (Topaz) NFC Forum Tag Type 2	Response example	80 or 90 (1)	09	80B30B8DB500	00	00	00	ISO/IEC 14443-A is bit oriented protocol, so we can receive non-integer amount of bytes. Number of significant bits in the 1 st byte is the same as indicated in the command sent. To calculate a position of a collision, application has to take index of byte first. Index of bit indicates a position inside this byte. Note that both indexes start from 0 and bit index can be 8, meaning that collision affected parity. Note that collision information is only valid when bit 'Collision is detected' is set. (2)
	Result code							
	Length of entire data field							
	Data received from TAG							
	7: Collision is detected							
	6: RFU							
5: CRC error								
4: Parity error								
[3:0]: Shows how many significant bits are there in the first byte								
7:0: Index of the first byte where collision is detected								
[7:4]: RFU								
[3:0]: Index of the first bit where collision is detected								
ISO/IEC 14443 Type B NFC Forum Tag Type 4B	Response example	80	0F	5092036A8D0 00000000071 71	3411	00		
	Result code							
	Length of entire data field							
	Data received from tag							
	Original (received) value of CRC							
	[7:2]: RFU							
1: CRC error if set								
0: RFU								
ISO/IEC 18092 NFC Forum Tag Type 3	Response example	80	12	01010105017B0...93FF	00		<<<0x801201010105017B 06941004014B024F4993F F00	
	Result code							
	Length of entire data field							
	Data received from tag							
	[7:2]: RFU							
	1: CRC error if set							
0: RFU								

1. Result code 90: Response is decoded but number of byte is not an integer.
2. For more information on using split frames, refer to [Appendix D on page 54](#).

For more detailed examples of use with NFC Forum and ISO/IEC 15693 tags, refer to [Appendix D on page 54](#).

If Parity Framing mode is used, the parity bit stays unchanged. On transmission, it is not encoded and on reception it is not decoded. The length of Data must be even. Each data byte is accompanied by an additional byte which encodes the parity:

<DataByte>, <Parity>, <DataByte>, <Parity> ...

Table 16. Structure of Parity byte

Bit	Description
7	Parity bit
[6:0]	Reserved for future use

On reception, bits [6:0] of the parity byte are zeroes; on transmission, bits [6:0] are ignored.

5.6 Idle command (0x07) description

This command switches the CR95HF into low consumption mode and defines the way to return to Ready state.

The Result code contains the Wake-up flag register value indicating to the application the wake-up event that caused the device to exit WFE mode.

Table 17. IDLE command description

Direction	Data	Comments	Example
Host to CR95HF	07	Command code	<p>Example of switch from Active mode to Hibernate state: >>>0x07 0E 08 04 00 04 00 18 00 00 00 00 00 00 00 00</p> <p>Example of switch from Active to WFE mode (wake-up by low pulse on IRQ_IN pin): >>>0x07 0E 08 01 00 38 00 18 00 00 60 00 00 00 00 00</p> <p>Example of switch from Active to WFE mode (wake-up by low pulse on SPI_SS pin): >>>0x07 0E 10 01 00 38 00 18 00 00 60 00 00 00 00 00</p> <p>Example of wake-up by Timeout (7 seconds): Duration before Timeout = $256 * t_L * (WU\ period + 2) * (MaxSleep + 1)$ >>>0x07 0E 01 21 00 38 00 18 00 60 60 00 00 00 00 08</p> <p>Example of switch from Active to Tag Detector mode (wake-up by tag detection or low pulse on IRQ_IN pin) (32 kHz, inactivity duration = 272 ms, DAC oscillator = 3 ms, Swing = 63 pulses of 13.56 MHz): >>>0x07 0E 0A 21 00 79 01 18 00 20 60 60 64 74 3F 08</p> <p>Example of a basic Idle command used during the Tag Detection Calibration process: >>>0x07 0E 03 A1 00 F8 01 18 00 20 60 60 00 xx 3F 01 where xx is the DacDataH value.</p>
	0E	Length of data	
	<WU Source>	Specifies authorized wake-up sources and the LFO frequency	
	EnterCtrlL	Settings to enter WFE mode	
	EnterCtrlH		
	WUCtrlL	Settings to wake-up from WFE mode	
	WUCtrlH		
	LeaveCtrlL	Settings to leave WFE mode (Default value = 0x1800)	
	LeaveCtrlH		
	<WUPeriod>	Period of time between two tag detection bursts. Also used to specify the duration before Timeout.	
	<OscStart>	Defines the Wait time for HFO to stabilize: <OscStart> * t _L (Default value = 0x60)	
	<DacStart>	Defines the Wait time for DAC to stabilize: <DacStart> * t _L (Default value = 0x60)	
	<DacDataL>	Lower compare value for tag detection ⁽¹⁾ . This value must be set to 0x00 during tag detection calibration.	
	<DacDataH>	Higher compare value for tag detection ⁽¹⁾ . This is a variable used during tag detection calibration.	
<SwingsCnt>	Number of swings HF during tag detection (Default value = 0x3F)		
<MaxSleep>	Max. number of tag detection trials before Timeout ⁽¹⁾ . This value must be set to 0x01 during tag detection calibration. Also used to specify duration before Timeout. MaxSleep must be: 0x00 < MaxSleep < 0x1F		

Table 17. IDLE command description (continued)

Direction	Data	Comments	Example
CR95HF to Host	0x00	Result code	This response is sent only when CR95HF exits WFE mode. <<<0x000101 Wake-up by Timeout <<<0x000102 Wake-up by tag detect <<<0x000108 Wake-up by low pulse on IRQ_IN pin
	0x01	Length of data	
	<Data>	Data (Wake-up source): 0x01: Timeout 0x02: Tag detect 0x08: Low pulse on <u>IRQ_IN</u> pin 0x10: Low pulse on <u>SPI_SS</u> pin	
CR95HF to Host	0x82	Error code	<<<0x8200 Invalid command length
	0x00	Length of data	

1. An initial calibration is necessary to determine DacDataL and DacDataH values required for leaving Tag Detector state. For more information, contact your ST sales office for the corresponding application note.

5.6.1 Idle command parameters

The Idle command (Host to CR95HF) has the following structure (all values are hexadecimal):

Table 18. Idle command structure

07	0E	xx	yy zz	yy zz	yy zz	aa	bb	cc	dd ee	ff	gg
Command code	Data length	WU source	Enter Control	WU Control	Leave Control	WU Period	Osc Start	DAC Start	DAC Data	Swing Count	Max Sleep

Table 19. Summary of Idle command parameters

Parameter	Description
Command code	This byte is the command code. '07' represents the Idle command. This command switches the device from Active mode to WFE mode.
Data length	This byte is the length of the command in bytes. Its value depends on the following parameter values.
WU Source	This byte defines the authorized wake-up sources in the Wake-up source register. Predefined values are: 0x01: Time out 0x02: Tag Detection 0x08: Low pulse on <u>IRQ_IN</u> 0x10: Low pulse on <u>SPI_SS</u>
Enter Control	These two bytes (EnterCtrlL and EnterCtrlH) define the resources when entering WFE mode. 0x0400: Hibernate 0x0100: Sleep (or 0x2100 if Timer source is enabled) 0xA200: Tag Detector Calibration 0x2100: Tag Detection
WU Control	These two bytes (WuCtrlL and WuCtrlH) define the wake-up resources. 0x0400: Hibernate 0x3800: Sleep 0xF801: Tag Detector Calibration 0x7901: Tag Detection

Table 19. Summary of Idle command parameters (continued)

Parameter	Description
Leave Control	These two bytes (LeaveCtrlL and LeaveCtrlH) define the resources when returning to Ready state. 0x1800: Hibernate 0x1800: Sleep 0x1800: Tag Detector Calibration 0x1800: Tag Detection
WU Period	This byte is the coefficient used to adjust the time allowed between two tag detections. Also used to specify the duration before Timeout. (Typical value: 0x20) Duration before Timeout = 256 * t _L * (WU period + 2) * (MaxSleep + 1)
Osc Start	This byte defines the delay for HFO stabilization. (Recommended value: 0x60) Defines the Wait time for HFO to stabilize: <OscStart> * t _L
DAC Start	This byte defines the delay for DAC stabilization. (Recommended value: 0x60) Defines the Wait time for DAC to stabilize: <DacStart> * t _L
DAC Data	These two bytes (DacDataL and DacDataH) define the lower and higher comparator values, respectively. These values are determined by a calibration process. When using the demo board, these values should be set to approximately 0x64 and 0x74, respectively.
Swing Count	This byte defines the number of HF swings allowed during Tag Detection. (Recommended value: 0x3F)
Max Sleep	This byte defines the maximum number of tag detection trials or the coefficient to adjust the maximum inactivity duration before Timeout. MaxSleep must be: 0x00 < MaxSleep < 0x1F This value must be set to 0x01 during tag detection calibration. Also used to specify duration before Timeout. Duration before Timeout = 256 * t _L * (WU period + 2) * (MaxSleep + 1) (Typical value: 0x28)

5.6.2 Using LFO frequency setting to reduce power consumption

In WFE mode, the high frequency oscillator (HFO) is stopped and most processes being executed are clocked by the low frequency oscillator (LFO). To minimize CR95HF power consumption in WFE mode, the slower the LFO frequency, the lower the power consumption.

Example 1: Setting a lower LFO frequency

The following equation defines a basic timing reference:

$$t_{REF} = 256 \cdot t_L \text{ ms (where } t_L = 1/f_{LFO})$$

$$t_{REF} = 8 \text{ ms (when bits [7:6] are set to "00", or 32 kHz)}$$

$$t_{REF} = 64 \text{ ms (when bits [7:6] are set to "11", or 4 kHz)}$$

5.6.3 Optimizing wake-up conditions

Using the Wake-up source register, it is possible to cumulate sources for a wake-up event. It is strongly recommended to always set an external event as a possible wake-up source.

To cumulate wake-up sources, simply set the corresponding bits in the Wake-up source register. For example, to enable a wake-up when a tag is detected (bit 1 set to '1') or on a low pulse on pin $\overline{\text{IRQ_IN}}$ (bit 3 set to '1'), set the register to 0x0A.

5.6.4 Using various techniques to return to Ready state

The Idle command and reply set offers several benefits to users by enabling various methods to return the CR95HF to Ready state. Some methods are nearly automatic, such as waiting for a timer overflow or a tag detection, but others consume more power compared to the ones requesting a host action. A description of each method follows below.

Default setting: from POR to Ready state

After power-on, the CR95HF enters Power-up state.

To wake up the CR95HF and set it to Ready state, the user must send a low pulse on the $\overline{\text{IRQ_IN}}$ pin. The CR95HF then automatically selects the external interface (SPI or UART) and enters Ready state and is able to accept commands after a delay of approximately 6 ms (t_3).

From Ready state to Hibernate state and back to Ready state

In Hibernate state, most resources are switched off to achieve an ultra-low power consumption.

The only way the CR95HF can wake-up from Hibernate state is by an external event (low pulse on pin $\overline{\text{IRQ_IN}}$).

A basic Idle command is:

```
>>>0x07 0E 08 04 00 04 00 18 00 00 00 00 00 00 00
```

Note: The Wake-up flag value is NOT significant when returning to Ready state from Hibernate state or after a POR.

From Ready state to Sleep state and back to Ready state

Wake-up by external event (low pulse on $\overline{\text{IRQ_IN}}$ or $\overline{\text{SPI_SS}}$ pin)

In Sleep or Power-up states, operating resources are limited in function of the selected wake-up source to achieve a moderate power consumption level.

An Idle command example when wake-up source is pin $\overline{\text{IRQ_IN}}$:

```
>>>0x07 0E 08 01 00 38 00 18 00 00 60 00 00 00 00
```

A similar command can be implemented using pin $\overline{\text{SPI_SS}}$ as a wake-up source:

```
>>>0x07 0E 10 01 00 38 00 18 00 00 60 00 00 00 00
```

Wake-up by timeout

The LFO is required to use the timer. However, this increases the typical power consumption by 80 μA . Several parameters can be modified to reduce power consumption as much as possible.

The Duration before Timeout is defined by parameters WU period and MaxSleep, respectively 0x60 and 0x08 in the following example.

Duration before Timeout = $256 * t_L * (WU \text{ period} + 2) * (MaxSleep + 1)$

Note: *Note that: 0x00 < MaxSleep < 0x1F.*

An Idle command example when wake-up source is timer (0x01) when $f_{LFO} = 32 \text{ kHz}$ (mean power consumption is 25 μA)

```
>>>0x07 0E 01 21 00 38 00 18 00 60 60 00 00 00 08
```

An Idle command example when wake-up source is timer (0xC1) when $f_{LFO} = 4 \text{ kHz}$ (mean power consumption is 20 μA):

```
>>>0x07 0E C1 21 00 38 00 18 00 60 60 00 00 00 08
```

The same command can be used mixing a timer and the $\overline{\text{IRQ_IN}}$ pin (0xC9) as a wake-up source:

```
>>>0x07 0E C9 21 00 38 00 18 00 60 60 00 00 00 08
```

Wake-up by Tag Detection

In this mode, the typical consumption can greatly vary in function of parameter settings (WU period without RF activity and Swing Count defining the RF burst duration). Using default settings, consumption in the range of 100 μA can be achieved.

Tag Detector is a state where CR95HF is able to detect an RF event, a wake-up will occur when a tag sufficiently modifies the antenna load and is detected by the CR95HF.

An Idle command example when wake-up source is Tag Detection (0x02):

```
>>>0x07 0E 02 21 00 79 01 18 00 20 60 60 64 74 3F 08
```

The same command can be used mixing Tag Detection and the $\overline{\text{IRQ_IN}}$ pin (0x0A) as a wake-up source:

```
>>>0x07 0E 0A 21 00 79 01 18 00 20 60 60 64 74 3F 08
```

The tag detection sequence is defined by dedicated parameters:

- WU source (Byte 3) (*Wake-up source register on page 49*)
 - The Timeout bit (bit 0) must be set to '1' in order to manage a certain number of emitted bursts. Otherwise, bursts will be sent indefinitely until a stop event occurs (for example, tag detection or a low pulse on pin $\overline{\text{IRQ_IN}}$).
 - The Tag Detect bit (bit 1) must be set to '1' to enable RF burst emissions.
 - It is recommended to also set Bits 3 or 4 to '1' to ensure that it is possible to leave Tag Detect mode via an external event (for example, a low pulse on pin $\overline{\text{IRQ_IN}}$).
- WU period (Byte 10): Defines the period of inactivity (t_{INACTIVE}) between two RF bursts:

$$t_{\text{INACTIVE}} = (WuPeriod + 2) * t_{\text{REF}}$$
- OscStart, DacStart (Bytes 11 and 12): Define the set-up time of the HFO and Digital Analog Converter, respectively. In general, 3 ms is used both set-up times.

$$\text{HFO | DAC set-up time} = (\text{OscStart | DacStart}) * t_L$$
- DacDataL, DacDataH (Bytes 13 and 14): Reference level for Tag Detection (calculated during the tag detection calibration process).
- SwingsCnt (Byte 15): Represents the number of 13.56-MHz swing allowed during a Tag Detection burst. We recommend using 0x3F.

- Maxsleep (Byte 16): The CR95HF emits (MaxSleep + 1) bursts before leaving Tag Detection mode if bit 0 (Timer Out) of the WU source register is set to '1'. Otherwise, when this bit is set to '0', a burst is emitted indefinitely.

Note: Bytes 4 to 9 should be used as shown in the examples in [Section 5.6: Idle command \(0x07\) description](#).

Note that the MaxSleep value is coded on the 5 least significant bits, thus: 0x00 < MaxSleep < 0x1F.

All the previously described command parameters must be chosen accordingly for the initial tag detection calibration when setting up the CR95HF.

Their value will impact tag detection efficiency, and CR95HF power consumption during Tag Detection periods.

5.6.5 Tag detection calibration procedure

The Idle command allows the use of a tag detection as a wake-up event. Certain parameters of the Idle command are dedicated to setting the conditions of a tag detection sequence.

During the tag detection sequence, the CR95HF regularly emits RF bursts and measures the current in the antenna driver I_{DRIVE} using the internal 6-bit DAC.

When a tag enters the CR95HF antenna RF operating volume, it modifies the antenna loading characteristics and induces a change in I_{DRIVE} , and consequently, the DAC data register reports a new value.

This value is then compared to the reference value established during the tag detection calibration process. This enables the CR95HF to decide if a tag has entered or not its operating volume.

The reference value (DacDataRef) is established during a tag detection calibration process using the CR95HF application setting with no tag in its environment.

The calibration process consists in executing a tag detection sequence using a well-known configuration, with no tag within the antenna RF operating volume, to determine a specific reference value (DacDataRef) that will be reused by the host to define the tag detection parameters (DacDataL and DacDataH).

During the calibration process, DacDataL is forced to 0x00 and the software successively varies the DacDataH value from its maximum value (0xFE) to its minimum value (0x00). At the end of the calibration process, DacDataRef will correspond to the value of DacDataH for which the wake-up event switches from Timeout (no tag in the RF field) to tag detected.

To avoid too much sensitivity of the tag detection process, we recommend using a guard band. This value corresponds to 2 DAC steps (0x08).

Recommended guard band value:

$$DacDataL = DacDataRef - Guard \text{ and } DacDataH = DacDataRef + Guard$$

The parameters used to define the tag detection calibration sequence (clocking, set-up time, burst duration, etc.) must be the same as those used for the future tag detection sequences.

When executing a tag detection sequence, the CR95HF compares the DAC data register value to the DAC Data parameter values (DacDataL and DacDataH) included in the Idle command. The CR95HF will exit WFE mode through a Tag Detection event if the DAC data register value is greater than the DAC Data parameter high value (DacDataH) or less than the DAC Data parameter low value (DacDataL). Otherwise, it will return to Ready state after a Timeout.

An efficient 8-step calibration algorithm is described in [Example of tag detection calibration process on page 50](#).

An example of a basic Idle command used during the Tag Detection Calibration process:

```
>>>0x07 0E 03 A1 00 F8 01 18 00 20 60 60 00 xx 3F 01
```

where xx is the DacDataH value.

An example of a tag detection sequence is provided in [Example of tag detection command using results of tag detection calibration on page 53](#).

5.7 Read Register (RdReg) command (0x08) description

This command is used to read the Wakeup register.

Table 20. RdREG command description

Direction	Data	Comments	Example
Host to CR95HF	0x08	Command code	Ex 1. >>>0x0803690100 Reads the ARC_B register. ⁽¹⁾ Ex 2. >>>0x0803620100 Reads the Wake-up event register.
	0x03	Length of data	
	0x62 or 0x69	Register address	
	0x01	Register size	
	0x00	ST Reserved	
CR95HF to Host	0x00	Result code	<<<0x000101 Wake-up by Timeout (Ex. 1)
	<Len>	Length of data (= RegCount)	<<<0x000102 Wake-up by Tag Detect (Ex. 1)
	<RegData>	Register data	<<<0x000113 Depth = 1, Gain = 3 (Ex. 2) <<< 0x000113 (ARC_B register) Depth = 1, Gain = 3 (Ex. 2). See Write Register description for more information on received data.
CR95HF to Host	0x82	Error code	<<<0x8200 Invalid command length
	0x00	Length of data	

1. This command must be preceded by the setting of the ARC_B register index (0x0903680004) .

Note: *The Management of the Analog Register Configuration register (ARC_B) is described in Section 5.8: Write Register (WrReg) command (0x09) description.*

5.8 Write Register (WrReg) command (0x09) description

The Write Register (WRREG) command (0x09) is used to:

- set the Analog Register Configuration address index value before reading or overwriting the Analog Register Configuration register (ARC_B) value
- set the Timer Window (TimerW) value used to improve CR95HF demodulation when communicating with ISO/IEC 14443 Type A tags
- set the AutoDetect Filter used to help synchronization of CR95HF with ISO/IEC 18092 tags
- configure the HF2RF bit^(a) to manage I_{CC} RF (V_{PS_TX}) consumption in Ready state

5.8.1 Improving RF performance

Adjusting the Modulation Index and Receiver Gain parameters helps improve application behavior.

The default value of these parameters ([Table 24](#)) is set by the PROTOCOLSELECT command, but they can be overwritten using the Write Register (WRREG) command (0x09). [Table 22](#) and [Table 23](#) list possible values for the Modulation Index and Receiver Gain parameters respectively.

This new configuration is valid until a new PROTOCOLSELECT or Write Register (of register ARC_B) command is executed. Register values are cleared at power off.

Table 21. WRREG command description (Modulation Index and Receiver Gain)

Direction	Data	Comments	Example
Host to CR95HF	0x09	Command code	
	0x03 or 0x04	Length of data	
	0x68	Analog Register Configuration address index	>>>0x090468010113 Update ARC_B value to 0x13
	0x00 or 0x01	Flag Increment address or not after Write command	>>>0x0903680001
	0x01	Index pointing to the Modulation Index and Receiver Gain values in the ARC_B register (0x01) (See Section 5.8.1)	Set Analog Register Index to 0x01 (ARC_B) ⁽¹⁾
	0xXX	New value for Modulation Index and Receiver Gain nibbles (See Section 5.8.1)	
CR95HF to Host	0x00	Result code	<<<0x0000
	0x00	Length of data (= RegCount)	Register written

1. This command must be executed before reading the ARC_B register (0x0803690100).

The default value of these parameters ([Table 24](#)) is set by the PROTOCOLSELECT command, but they can be overwritten using the Write Register (WRREG) command (0x09).

a. When the HF2RF bit is '0', Reader mode is possible (default mode). When set to '1', V_{PS_TX} power consumption is reduced (Ready mode).

This new configuration is valid until a new PROTOCOLSELECT or Write Register (of register) command is executed. Register values are cleared at power off.

How to modify Analog Register Configuration register (ARC_B) values

1. Use the PROTOCOLSELECT command (0x02) to select the correct communication protocol.

For example, to select the ISO/IEC 18092 protocol:

```
Send PROTOCOLSELECT command: >>>0x02020451
CR95HF reply: <<<0x0000
```

2. Read the Analog Register Configuration register (ARC_B) value.

```
a) Write the ARC_B register index at 0x01: >>>0x0903680001
CR95HF reply: <<<0x0000
b) Read the ARC_B register value: >>>0x0803690100
CR95HF reply: <<<0x015F
```

In this example, the ARC_B register value is 0x5F, where “5” is the Modulation Index and “F” is the Receiver Gain.

3. Modify the Modulation Index and Receiver Gain values with 0x23.

```
Write the ARC_B register index: >>>0x090468010123
CR95HF reply: <<<0x0000
```

4. Read the Analog Configuration register (ARC_B) value.

```
a) Write the ARC_B register index at 0x01: >>>0x0903680001
CR95HF reply: <<<0x0000
b) Read the ARC_B register value: >>>0x0803690100
CR95HF reply: <<<0x0123
```

Modulation Index and Receiver Gain values

Table 22. Possible Modulation Index values

Code	1	2	3	4	5	6	D
Modulation Index ⁽¹⁾	10%	17%	25%	30%	33%	36%	95%

1. Characterized only using ISO/IEC 10373 test set-up.

Table 23. Possible Receiver Gain values

Code	0	1	3	7	F
Receiver Gain ⁽¹⁾	34 dB	32 dB	27 dB	20 dB	8 dB

1. Characterized by design simulation.

Default code per protocol

Table 24. ARC_B default code for available Reader protocols

Communication protocol	Default value	Recommended values for CR95HF demo board	Possible Modulation Index values (MS nibble)	Possible Receiver Gain values (LS nibble)
ISO/IEC 14443 Type A reader	0xDF	0xD1 or 0xD3	0xD	0x0, 0x1, 0x3, 0x7 or 0xF
ISO/IEC 14443 Type B reader	0x2F	0x20	0x1, 0x2, 0x3 or 0x4	0x0, 0x1, 0x3, 0x7 or 0xF
ISO/IEC 18092 reader	0x5F	0x20	0x1, 0x2, 0x3 or 0x4	0x0, 0x1, 0x3, 0x7 or 0xF
ISO/IEC 15693 reader 30%	0x53	0x50	0x4, 0x5 or 0x6	0x0, 0x1, 0x3, 0x7 or 0xF
ISO/IEC 15693 reader 100%	0xD3	0xD0	0xD	0x0, 0x1, 0x3, 0x7 or 0xF

5.8.2 Improving frame reception for ISO/IEC 14443 Type A tags

To improve CR95HF demodulation when communicating with ISO/IEC 14443 Type A tags, it is possible to adjust the synchronization between digital and analog inputs by fine-tuning the Timer Window (TimerW) value. This can be done using the Write Register (WRREG) command to set a new TimerW value (min. 0x50, max. 0x60). The recommended value is 0x56 or 0x58 when using the CR95HF demo board.

The default value of this parameter (0x52) is set by the PROTOCOLSELECT command, but it can be overwritten using the WRREG command (0x09).

Table 25. WRREG command description (Timer Window)

Direction	Data	Comments	Example
Host to CR95HF	0x09	Command code	>>>0x09043A005804 Set recommended TimerW value.
	0x03 or 0x04	Length of data	
	0x3A	Timer Window (TimerW) value	
	0x00 or 0x01	Flag Increment address or not after Write command	
	0xXX	Set TimerW value (recommended value is 0x56 or 0x58)	
CR95HF to Host	0x04	TimerW value confirmation	<<<0x0000 Register written
	0x00	Result code	
	0x00	Length of data (= RegCount)	

5.8.3 Improving RF reception for ISO/IEC 18092 tags

To improve CR95HF reception when communicating with ISO/IEC 18092 tags, it is possible to enable an AutoDetect filter to synchronize ISO/IEC 18092 tags with the CR95HF. This can be done using the Write Register (WRREG) command to enable the AutoDetect filter.

By default, this filter is disabled after the execution of the PROTOCOLSELECT command, but it can be enabled using the WRREG command (0x09).

5.9 BaudRate command (0x0A) description

This command changes the UART baud rate.

Table 26. BAUDRATE command description

Direction	Data	Comments	Example
Host to CR95HF	0x0A	Command code	
	0x01	Length of data	
	<BaudRate>	New Baud Rate = $13.56 / (2 * \text{<BaudRate>} + 2)$ Mbps Baud rate 255: 13.56/512 ~26.48 Kbps 254: 13.56/510 ~26.59 Kbps 253: 13.56/508 ~26.7 Kbps ... 117: 13.56/236 ~57.7 Kbps (Value after power-up) ... 2: 13.56/6 ~2.26 Mbps 1: RFU 0: RFU	
CR95HF to Host	0x55	Code response of 0x55	<<<0x55 New baud rate is used to reply

Caution: If the BaudRate command is not correctly executed, the baud rate value will remain unchanged.

5.10 Echo command (0x55) description

The ECHO command verifies the possibility of communication between a Host and the CR95HF.

Table 27. ECHO command description

Direction	Data	Comments	Example
Host to CR95HF	0x55	Command code	
CR95HF to Host	0x55	Code response	>>> 0x55: Sends an ECHO command <<< 0x55: Response to an ECHO command



6 Electrical characteristics

6.1 Absolute maximum ratings

Table 28. Absolute maximum ratings

Symbol	Parameter	Value	Unit
VPS_Main	Supply voltage ⁽¹⁾	-0.3 to 7.0	V
VPS_TX	Supply voltage (RF drivers)	-0.3 to 7.0	V
V _{IO}	Input or output voltage relative to ground	-0.3 to VPS_Main +0.3	V
V _{MaxCarrier}	Maximum input voltage (pins RX1 and RX2)	±14.0	V
T _A	Ambient operating temperature	-25 to +85	°C
	Ambient operating temperature (RF mode)	-25 to +85	
T _{STG}	Storage temperature (Please also refer to package specification).	-65 to +150	°C
T _{LEAD}	Lead temperature during soldering	See note ⁽²⁾	°C
V _{ESD}	Electrostatic discharge voltage according to JESD22-A114, Human Body Model	2000	V
P _{TOT} ⁽³⁾	Total power dissipation per package	1	W

1. To properly reset the device, VPS_Main must be tied to 0V before executing the start-up sequence.
2. Compliant with JEDEC standard J-STD-020D (for small-body, Sn-Pb or Pb assembly), the ST ECOPACK® 7191395 specification, and the European directive on Restrictions on Hazardous Substances (RoHS directive 2011/65/EU of July 2011).
3. Depending on the thermal resistance of package.

Note: *Stresses listed above may cause permanent damage to the device. This is a stress rating only and functional operation of the device at these or any other conditions above those indicated in the operational sections of the specification is not implied. Exposure to absolute maximum rating conditions for extended periods may affect device reliability.*

6.2 DC characteristics

Table 29. DC characteristics

Symbol	Parameter	Condition	Min.	Typ.	Max.	Unit
VPS_Main	Supply voltage		2.7	3.0	5.5	V
VPS_TX	Supply voltage (RF drivers)		2.7	3.0	5.5	V
V _{IL}	Input low voltage (I/Os)		0		0.2 x VPS_Main	V
V _{IH}	Input high voltage (I/Os)		0.7 x VPS_Main		VPS_Main	V
V _{OH}	Output high voltage (I/Os)	I _{OH} = - 8 µA	0.7 x VPS_Main		VPS_Main	V
V _{OL}	Output low voltage (I/Os)	I _{OLMAX} = 500 µA	0		0.15 x VPS_Main	V
POR	Power-on reset voltage			1.8		V

6.3 Power consumption characteristics

T_A = -25°C to 85°C, unless otherwise specified.

Table 30. Power consumption characteristics (VPS_Main from 2.7 to 3.3 V)

Symbol	Parameter	Condition	Typ.	Max.	Unit
I _{CC} (V _{PS}) Power-up	Supply current in power-up state	T _A = 25°C	200	600	µA
I _{CC} (V _{PS}) Hibernate	Supply current in Hibernate state	T _A = 25°C	1	5	µA
I _{CC} (V _{PS}) Sleep	Supply current in Sleep state	T _A = 25°C	20	80	µA
I _{CC} (V _{PS}) Ready	Supply current in Ready state	T _A = 25°C	2.5	5.0	mA
I _{CC} (V _{PS}) Tag Detect	Average supply current in Tag Detector state	T _A = 25°C, 4 RF bursts per second	50	100	µA

The CR95HF supports two VPS_TX supply ranges for RF drivers: 2.7V to 3.3V or 4.5V to 5.5V. Antenna matching circuit must be defined accordingly.

Table 31. Power consumption characteristics (VPS_TX from 2.7 to 3.3 V)

Symbol	Parameter	Condition	Typ.	Max.	Unit
I _{CC} RF (V _{PS_TX}) RF Field ON	Supply current in RF Field (Reader mode) ⁽¹⁾	T _A = 25°C	70	100	mA
I _{CC} RF (V _{PS_TX}) RF Field OFF	Supply current in RF Field (Ready mode) ⁽²⁾	T _A = 25°C		200	µA
I _{CC} RF (V _{PS_TX}) Tag Detect	Peak ⁽³⁾ current during Burst detection	T _A = 25°C	70	100	mA

- Parameter measured using recommended output matching network. (Z load is 27 Ω and 0°).
- This consumption can be reduced to approximately 2 µA (typ.) by setting a control bit (bit HF2RF) to '1' using command 090468010710. In this case, Reader mode is not available. To re-enable Reader mode, reset the HF2RF bit to '0' using the command 090468010700 or execute a new PROTOCOLSELECT command.
- The maximum differential input voltage between pins RX1 and RX2 (VRx1-Rx2) has a peak-peak of 18 V.

Table 32. Power consumption characteristics (VPS_TX from 4.5 to 5.5 V)

Symbol	Parameter	Condition	Typ.	Max.	Unit
$I_{CC\ RF}$ (VPS_TX) RF Field ON	Supply current in RF Field (Reader mode) ⁽¹⁾	T _A = 25°C	120	200	mA
$I_{CC\ RF}$ (VPS_TX) RF Field OFF	Supply current in RF Field (Ready mode) ⁽²⁾	T _A = 25°C		300	μA
$I_{CC\ RF}$ (VPS_TX) Tag Detect	Peak ⁽³⁾ current during Burst detection	T _A = 25°C	120	200	mA

1. Parameter measured using recommended output matching network. (Z load is 16 Ω and 0°).
2. This consumption can be reduced to approximately 2 μA (typ.) by setting a control bit (bit HF2RF) to '1' using command 090468010710. In this case, Reader mode is not available.
To re-enable Reader mode, reset the HF2RF bit to '0' using the command 090468010700 or execute a new PROTOCOLSELECT command.
3. The maximum differential input voltage between pins RX1 and RX2 (VRx1-Rx2) has a peak-peak of 18 V. This voltage can be limited by adding a damping resistor in parallel of the antenna or between ST_R0 and Ground.

6.4 SPI characteristics

The CR95HF supports (CPOL = 0, CPHA = 0) and (CPOL = 1, CPHA = 1) modes.

Table 33. SPI interface characteristics

Symbol	Parameter	Condition	Min.	Max.	Unit
f_{SCK} 1/ $t_{c(SCK)}$	SPI clock frequency			2.0	MHz
V_{IL}	Input low voltage			$0.3 \times V_{PS}$	V
V_{IH}	Input high voltage		$0.7 \times V_{PS}$		
V_{OL}	Output low voltage			$0.4 \times V_{PS}$	
V_{OH}	Output high voltage		$0.7 \times V_{PS}$		
$t_{SU(NSS)}^{(1)}$	NSS setup time		70		ns
$t_{h(NSS)}^{(1)}$	NSS hold time		0		
$t_{CH(SCKL)}^{(1)}$	Clock low time		200		ns
$t_{CH(SCKH)}^{(1)}$	Clock high time		200		
$t_{SU(SI)}^{(1)}$	Data slave Input setup time		20		ns
$t_{h(SI)}^{(1)}$	Data slave Input hold time		80		
$t_{v(SO)}^{(1)}$	Data slave output valid time			80	ns
$t_{h(SO)}^{(1)}$	Data slave output hold time	After enable edge	150		
$C_{b_SPI_IN}$	Capacitive load for input pins NSS, CLK, MOSI			3	pF
$C_{b_SPI_OUT}$	Capacitive load for input pins MOSI			20	pF

1. Values based on design simulation and/or characterization results, and not on tested in production.

Figure 14. SPI timing diagram (Slave mode and CPOL = 0, CPHA = 0)

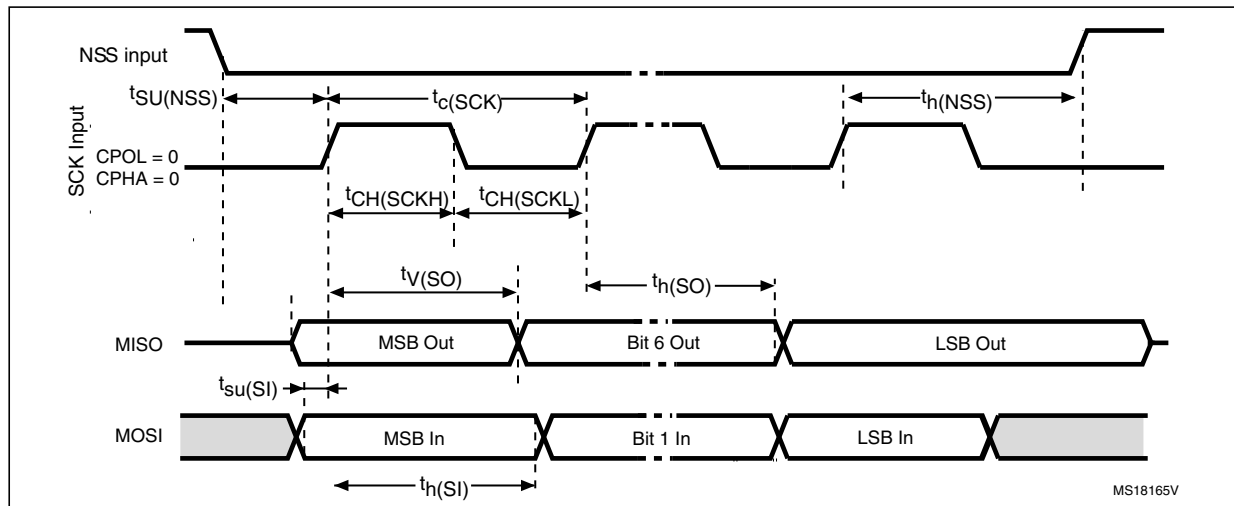

Figure 15. SPI timing diagram (Slave mode and CPOL = 1, CPHA = 1)

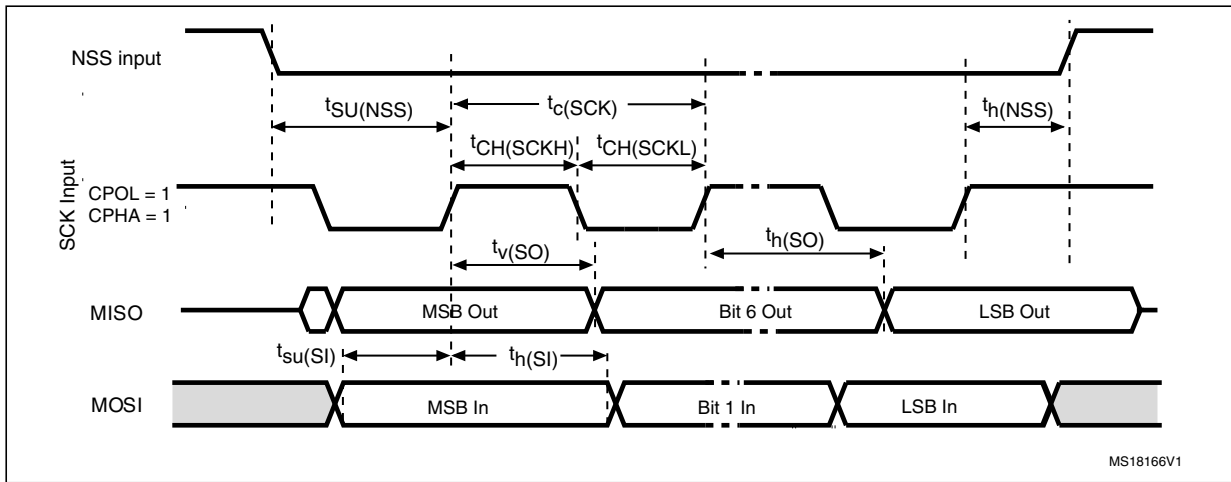

Figure 16.

6.5 RF characteristics

Test conditions are $T_A = 0^\circ\text{C}$ to 50°C , unless otherwise specified.

Table 34. Reader characteristics

Symbol	Parameter	Min.	Typ.	Max.	Unit
f_c	Frequency of operating field (carrier frequency)	13.553	13.56	13.567	MHz
MI Carrier	Carrier modulation index ⁽¹⁾ ISO/IEC 14443-A			100	%
	ISO/IEC 14443-B	8		14	
	ISO/IEC 18092	8		14	
	ISO/IEC 15693 (10% modulation) ⁽²⁾	10		30	
	ISO/IEC 15693 (100% modulation)	80		100	
Transmitter specifications (VPS_TX = 2.7 to 3.3 V)					
	Z_{OUT} differential impedance between TX1 and TX2 ⁽¹⁾		27		Ω
	Output power for 3V operation on pin VPS_TX ⁽¹⁾⁽²⁾		55		mW
Transmitter specifications (VPS_TX = 4.5 to 5.5 V)					
	Z_{OUT} differential impedance between TX1 and TX2 ⁽¹⁾		16		Ω
	Output power for 5V operation on pin VPS_TX ⁽¹⁾⁽²⁾		230		mW
Receiver specifications					
	Small signal differential input resistance (Rx1/Rx2) ⁽¹⁾		100		k Ω
VRx1-Rx2	Differential input voltage between pins RX1 and RX2 ⁽³⁾			18	V
	Small signal differential input capacitance (Cx1/Cx2) ⁽¹⁾		22		pF
	Sensitivity (106 Kbps data rate) ⁽⁴⁾		8		mV

1. Maximum values based on design simulation and/or characterization results, and not tested in production.
2. Parameter measured on samples using recommended output matching network. (Z load is 27 Ω and 0°.)
3. This voltage can be limited by adding a damping resistor in parallel of the antenna or between ST_R0 and Ground.
4. Based on ISO/IEC 10373-6 protocol measurement. The reader sensitivity corresponds to the load modulation value of the REQ reply sent by an ISO reference card when decoded by the CR95HF.

6.6 Oscillator characteristics

The external crystal used for this product is a 27.12 MHz crystal with an accuracy of ± 14 kHz.

Table 35. HFO 27.12 MHz oscillator characteristics^{(1) (2)}

Symbol	Parameter	Conditions	Min.	Typ.	Max.	Unit
f_{XTAL}	Oscillator frequency			27.12		MHz
R_F	Feedback resistor			2		M Ω
C	Recommended load capacitance versus equivalent serial resistance of the crystal (R_S) ⁽³⁾	$R_S = 30 \Omega$		6		pF
$t_{SU(HFO)}$ ⁽⁴⁾	Startup time	V_{PS} is stabilized		6	10	ms

1. Resonator characteristics given by the crystal/ceramic resonator manufacturer.
2. Based on characterization, not tested in production.
3. The relatively low value of the R_F resistor offers a good protection against issues resulting from use in a humid environment, due to the induced leakage and the bias condition change. However, it is recommended to take this point into account if the Host is used in tough humidity conditions.
4. $t_{SU(HFO)}$ is the startup time measured from the moment it is enabled (by software) to a stabilized 27.12 MHz oscillation is reached. This value is measured for a standard crystal resonator and it can vary significantly with the crystal manufacturer.

For C_{L1} and C_{L2} , it is recommended to use high-quality external ceramic capacitors in the 10 pF to 20 pF range (typ.), designed for high-frequency applications, and selected to match the requirements of the crystal or resonator (see [Figure 17](#)). C_{L1} and C_{L2} are usually the same size. The crystal manufacturer typically specifies a load capacitance which is the series combination of C_{L1} and C_{L2} .

Figure 17. Typical application with a 27.12 MHz crystal

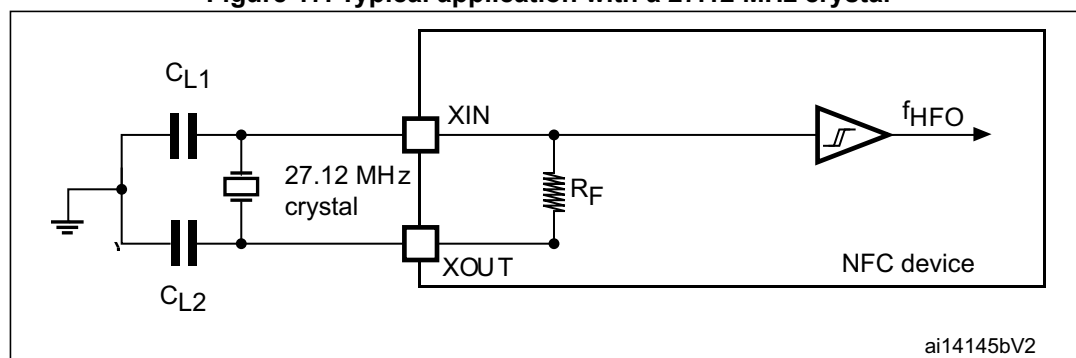

Note:

For C_{L1} and C_{L2} it is recommended to use high-quality ceramic capacitors in the 10 pF to 20 pF range selected to match the requirements of the crystal or resonator. C_{L1} and C_{L2} are usually the same size. The crystal manufacturer typically specifies a load capacitance which is the series combination of C_{L1} and C_{L2} .

Load capacitance C_L has the following formula: $C_L = C_{L1} \times C_{L2} / (C_{L1} + C_{L2}) + C_{stray}$ where C_{stray} is the pin capacitance and board or trace PCB-related capacitance. Typically, it is between 2 pF and 7 pF.

7 Package mechanical data

In order to meet environmental requirements, ST offers these devices in different grades of ECOPACK® packages, depending on their level of environmental compliance. ECOPACK® specifications, grade definitions and product status are available at: www.st.com. ECOPACK® is an ST trademark.

This device is available in a 32-lead, 5x5 mm, 0.5 mm pitch, very thin fine pitch quad flat pack no-lead package (VFQFPN).

Figure 18. 32-lead VFQFPN package outline

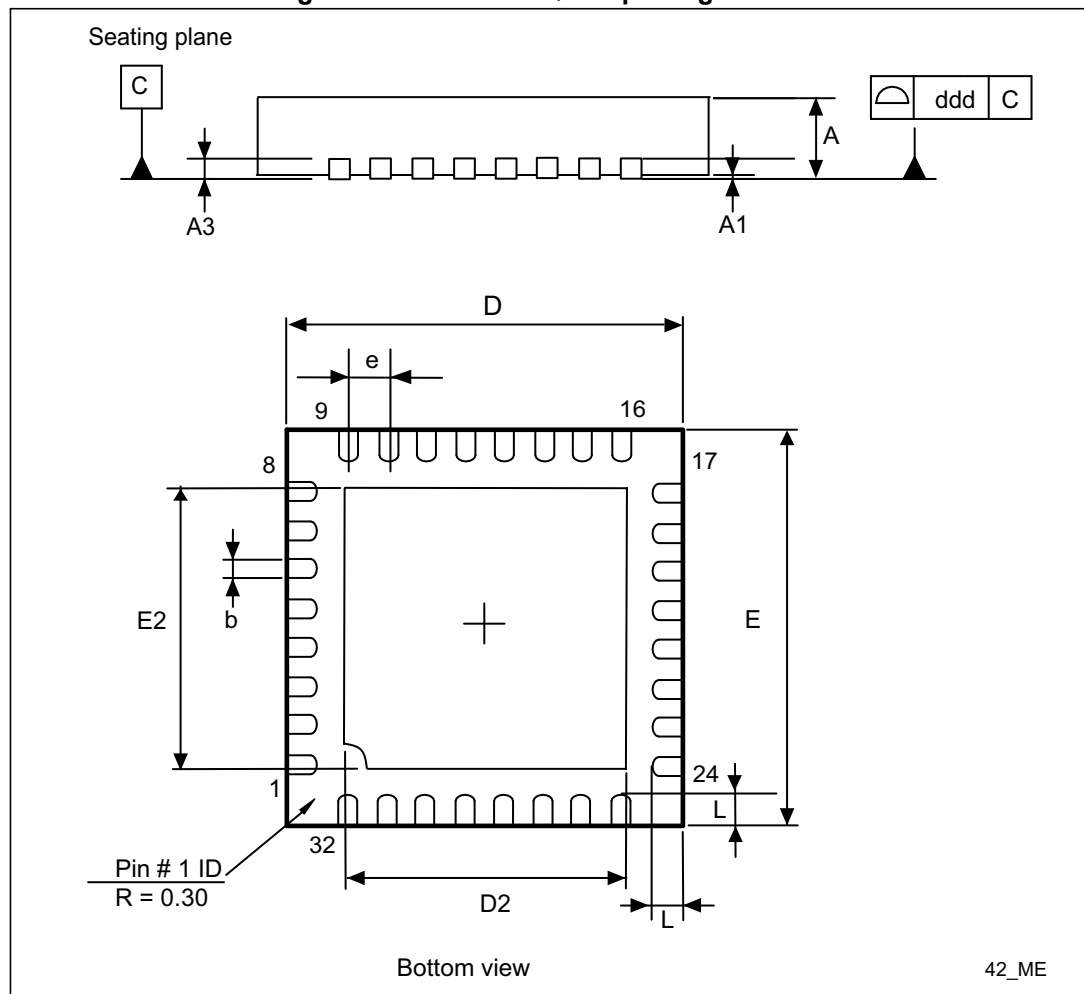

Table 36. 32-pin VFQFPN package mechanical data

Symbol	millimeters			inches ⁽¹⁾			Note
	Min.	Typ.	Max.	Min.	Typ.	Max.	
A	0.800	0.900	1.000	0.0315	0.0354	0.0394	
A1	0.000	0.020	0.050	0.0000	0.0008	0.0020	
A3		0.200			0.0079		
b	0.180	0.250	0.300	0.0071	0.0098	0.0118	
D	4.850	5.000	5.150	0.1909	0.1969	0.2028	
D2 (AMK_B)	3.500	3.600	3.700	0.1378	0.1417	0.1457	1
E	4.850	5.000	5.150	0.1909	0.1969	0.2028	
E2 (AMK_B)	3.500	3.600	3.700	0.1378	0.1417	0.1457	1
e		0.500			0.0197		
L	0.300	0.400	0.500	0.0118	0.0157	0.0197	
ddd (AMK)			0.050			0.0020	2

1. Values in inches are rounded to 4 decimal digits.

Note: 1 AMKOR Variation B. Dimensions are not in accordance with JEDEC.
2 AMKOR.

8 Part numbering

Table 37. Ordering information scheme

Example:	CR	95	HF	-V	MD	5	T
Device type CR = Contactless reader IC							
Wired access 95 = SPI and UART							
Frequency band HF = High frequency (13.56 MHz)							
Operating voltage V = 2.7 to 5.5 V							
Package MD = 32-pin VFQFPN (5 x 5 mm)							
Operating temperature 5 = -25° to +85° C							
Packaging T = Tape and Reel							

Not all combinations are necessarily available. For a list of available options (speed, package, etc.) or for further information on any aspect of this device, please contact your nearest STMicroelectronics Sales Office.

Appendix A Additional Idle command description

This section provides examples of use for the IDLE command.

The wake-up source is the third of the 16 bytes in the IDLE command. This byte specifies authorized Wake-up events. This revision now also provides the capability to set the LFO frequency in WFE mode.

The LFO frequency and the authorized wake-up source settings are stored in the Wake-up source register as the parameters of the IDLE command.

The Wake-up event is updated by the CR95HF when it exits WFE mode.

The contents of the Wake-up event register can be read using the Read Register command or in the CR95HF reply to the Idle command.

Table 38. Wake-up source register

Bits [7:6]	Bit 5	Bit 4	Bit 3	Bit 2	Bit 1	Bit 0
LFO frequency	RFU ⁽¹⁾	IRQ on pin SPI_SS	IRQ on pin IRQ_IN	RFU ⁽¹⁾	Tag Detect	Timeout

1. Must be set to '0'.

Table 39. Wake-up event register

Bits [7:6]	Bit 5	Bit 4	Bit 3	Bit 2	Bit 1	Bit 0
LFO frequency	RFU	IRQ on pin SPI_SS	IRQ on pin IRQ_IN	RFU	Tag Detect	Timeout

Bits [7:6] define the LFO frequency (f_{LFO}):

00: 32 kHz 01: 16 kHz
10: 8 kHz 11: 4 kHz

Bit 4: When set, the CR95HF will wake up when an external interrupt (low level on pin SPI_SS) is detected. This is useful for UART communication.

Bit 3: When set, the CR95HF will wake up when an external interrupt (low level on pin IRQ_IN) is detected. This is useful for SPI communication. It is recommended to set this bit to '1' in order to recover in the event of a system crash.

Bit 1: When set, the CR95HF will wake up when a tag is detected in the RF field. This bit must also be set during Tag Detection calibration or during a Tag Detection sequence.

Bit 0: When set, the CR95HF will wake up and return to Ready state at the end of a predefined cycle. The Timeout (TO) value is defined by the MaxSleep and Wake-up period:

$$TO = (MaxSleep * (WuPeriod + 1)) * t_{REF}$$

$$t_{REF} = 256 * t_L = 8 \text{ ms } (f_{LFO} = 32 \text{ kHz}), \text{ mean power consumption in Sleep mode is } 25 \mu\text{A}$$

$$t_{REF} = 256 * t_L = 64 \text{ ms } (f_{LFO} = 4 \text{ kHz}), \text{ mean power consumption in Sleep mode is } 20 \mu\text{A}$$

Note: *Note that: 0x00 < MaxSleep < 0x1F.*

This bit must be set when using the timer as a possible wake-up source. It must be set during Tag Detection Calibration to force a wake-up after the first Tag Detection trial.

Appendix B Example of tag detection calibration process

The following script works on the DEMO_CR95HF evaluation board and with the CR95HF development software available from the ST internet site.

This is a dichotomous approach to quickly converge to the DacDataRef value for which a wake-up event switches from tag detection to Timeout. In this process, only the DacDataH parameter is changed in successive Idle commands. And we look at the wake-up event reply to decide the next step.

```
00 01 02 corresponds to a Tag Detect,  
00 01 01 corresponds to a Timeout.
```

```
REM, Tag Detection Calibration Test
```

```
REM, Sequence: Power-up Tag Detect Wake-up by Tag Detect (1 try  
measurement greater or equal to DacDataH) or Timeout
```

```
REM, CMD 07 0E 03 A100 D801 1800 01 60 60 00 XX 3F 00
```

```
REM, 03 WU source = Tagdet or Timeout
```

```
REM, A100 Initial Dac Compare
```

```
REM, F801 Initial Dac Compare
```

```
REM, 1800 HFO
```

```
REM, 20 Wup Period 32 Inactivity period = 256ms (LFO @ 32kHz)
```

```
REM, 60 Osc 3ms (LFO @ 32kHz)
```

```
REM, 60 Dac 3ms (LFO @ 32kHz)
```

```
REM, 00 DacDataL = minimum level (floor)
```

```
REM, xx DacDataH 00 = minimum level (ceiling)
```

```
REM, 3F Swing 13.56 4.6 us
```

```
REM, 01 Maximum number of Sleep before Wakeup 2
```

```
REM, Tag Detection Calibration Test
```

```
REM, During tag detection calibration process DacDataL = 0x00
```

```
REM, We execute several tag detection commands with different  
DacDataH values to determine DacDataRef level corresponding to  
CR95HF application set-up
```

```
REM, DacDataReg value corresponds to DacDataH value for which Wake-  
up event switches from Timeout (0x01) to Tag Detect (0x02)
```

```
REM, Wake-up event = Timeout when DacDataRef is between DacDataL  
and DacDataH
```

```
REM, Search DacDataRef value corresponding to value of DacDataH for  
which Wake-up event switches from Tag Detect (02) to Timeout(01)
```

```
REM, Step 0: force wake-up event to Tag Detect (set DacDataH = 0x00)
REM, With these conditions Wake-Up event must be Tag Detect
>>> CR95HFDLL_STCMD, 01070E03A100F80118002060600003F01
<<< 000102
REM, Read Wake-up event = Tag Detect (0x02); if not, error .

REM, Step 1: force Wake-up event to Timeout (set DacDataH = 0xFC)
REM, With these conditions, Wake-Up event must be Timeout
>>> CR95HFDLL_STCMD, 01070E03A100F801180020606000FC3F01
<<< 000101
REM, Read Wake-up event = Timeout (0x01); if not, error .

REM, Step 2: new DacDataH value = previous DacDataH +/- 0x80
REM, If previous Wake-up event was Timeout (0x01) we must decrease
DacDataH (-0x80)
>>> CR95HFDLL_STCMD, 01070E03A100F8011800206060007C3F01
<<< 000101
REM, Read Wake-up event = Timeout (0x01) or Wake-up event = Tag
Detect (0x02)

REM, Step 3: new DacDataH value = previous DacDataH +/- 0x40
REM, If previous Wake-up event was Timeout (0x01), we must decrease
DacDataH (-0x40); else, we increase DacDataH (+ 0x40)
>>> CR95HFDLL_STCMD, 01070E03A100F8011800206060003C3F01
<<< 000102
REM, Read Wake-up event = Timeout (0x01) or Wake-up event = Tag
Detect (0x02)

REM, Step 4: new DacDataH value = previous DacDataH +/- 0x20
REM, If previous Wake-up event was Timeout (0x01), we must decrease
DacDataH (-0x20); else, we increase DacDataH (+ 0x20)
>>> CR95HFDLL_STCMD, 01070E03A100F8011800206060005C3F01
<<< 000102
REM, Read Wake-up event = Timeout (0x01) or Wake-up event = Tag
Detect (0x02)
```

```
REM, Step 5: new DacDataH value = previous DacDataH +/- 0x10
REM, If previous Wake-up event was Timeout (0x01), we must decrease
DacdataH (-0x10); else, we increase DacDataH (+ 0x10)
>>> CR95HFDLL_STCMD, 01070E03A100F8011800206060006C3F01
<<< 000102

REM, Read Wake-up event = Timeout (0x01) or Wake-up event = Tag
Detect (0x02)

REM, Step 6: new DacDataH value = previous DacDataH +/- 0x08
REM, If previous Wake-up event was Timeout (0x01), we must decrease
DacDataH (-0x08); else, we increase DacDataH (+ 0x08)
>>> CR95HFDLL_STCMD, 01070E03A100F801180020606000743F01
<<< 000101

REM, Read Wake-up event = Timeout (0x01) or Wake-up event = Tag
Detect (0x02)

REM, Step 7: new DacDataH value = previous DacDataH +/- 0x04
REM, If previous Wake-up event was Timeout (0x01), we must decrease
DacDataH (-0x04); else, we increase DacDataH (+ 0x04)
>>> CR95HFDLL_STCMD, 01070E03A100F801180020606000703F01
<<< 000101

REM, Read Wake-up event = Timeout (0x01) or Wake-up event = Tag
Detect (0x02)

REM, If last Wake-up event = Tag Detect (0x02), search DacDataRef =
last DacDataH value
REM, If last Wake-up event = Timeout (0x01), search DacDataRef =
last DacDataH value -4

REM, For tag detection usage, we recommend setting DacDataL =
DacDataRef -8 and DacDataH = DacDataRef +8

>>> CR95HFDLL_STCMD, 01070E0B21007801180020606064743F01
<<< 000101
```

Appendix C Example of tag detection command using results of tag detection calibration

The following script works on the DEMO_CR95HF evaluation board and with the CR95HF development software available from the ST internet site.

This is an example of a Tag Detection command when a tag is not present in the RF operating volume using the CR95HF:

```
>>> CR95HFDLL_STCMD, 01 070E0B21007801180020606064743F01
<<< 000101 Wake-up event = Timeout (0x01)
>>> CR95HFDLL_STCMD, 01 0803620100
<<< 000101
```

This is an example of a Tag Detection command when a tag is present in the RF operating volume using the CR95HF:

```
>>> CR95HFDLL_STCMD, 01 070E0B21007801180020606064743F01
<<< 000102 Wake-up event = Tag Detect (0x02)
>>> CR95HFDLL_STCMD, 01 0803620100
<<< 000102
```

Appendix D Examples of CR95HF command code to activate NFC Forum and ISO/IEC 15693 tags

The following script works on the DEMO_CR95HF evaluation board and with the CR95HF development software available from the ST internet site.

This section provides examples of CR95HF command code used to activate NFC Forum and ISO/IEC 15693 tags using CR95HF development software.

CR95HFDLL_STCMD: Is the standard CR95HF frame exchange command. In this command, the first byte 01 is not sent, it is only requested by the CR95HF development software in order to recognize if it is a user or service command.

CR95HFDLL_SENDRECV: Is the encapsulated CR95HF SendReceive command for which command codes, number of bytes, and CRC are automatically appended to the parameter.

In this section,

- The CR95HF command overhead (command code, length of data and transmission flag) is in black.
- The Tag instruction is in blue.
- The CR95HF response overhead (result code, length of data and status) is in green.
- The Tag response is in red.

When the CRC append option is set in the Protocol Select command, the CRC is automatically appended by the CR95HF, but the CRC is not visible in the instruction log file.

When the CRC is present in the command or response, CRC reply is in *italics*.

The following symbols correspond to:

- >>> Frame sent by Host to CR95HF
- <<< Frame received by Host from CR95HF

D.1 ISO/IEC 14443 Type A

D.1.1 NFC Forum Tag Type 1 (Topaz)

```
REM, CR95HF code example to support NFC Forum Tag Type 1 14443_A
REM, TEST TOPAZ 14443A (UID 6E567A00)
REM, first byte 01 in CR95HFDLL_STCMD is only requested by CR95HF
Development SW
REM, RFOFF
>>> CR95HFDLL_STCMD, 01 02020000
<<< 0000
REM, TEST TOPAZ 14443A (UID 6E567A00)
REM, Sel Prot 14443A option TOPAZ
>>> CR95HFDLL_STCMD, 01 020402000300
<<< 0000
```

REM, Optimization of synchronization between digital and analog inputs by adjusting TimerW value (default 0x52, min. 0x50, max. 0x60). Recommended value is 0x56 or 0x58 for NFC Forum Tag Type 1 (Topaz).

>>> CR95HFDLL_STCMD, 01 09043A005804

<<< 0000

REM, Recommended modulation and gain is 0xD1 or 0xD3 for NFC Forum Tag Type 1 (Topaz).

>>> CR95HFDLL_STCMD, 01 0904680101D1

<<< 0000

REM, last Byte x7 or x8 in CR95HFDLL_SENDRECV command number of bits in the 14443 _Type A frame

REM, REQA reply ATQA 000C

>>> CR95HFDLL_STCMD, 01 04 02 26 07

<<< 80 05 000C 280000

REM, RID reply HR0 HR1 UID0 UID 1 UID2 UID3

>>> CR95HFDLL_STCMD, 01 04 08 7800000000000000 A8

<<< 80 0B 11 48 6E567A00 3E45 080000

REM, RAll 0408 0000 UID0 UID 1 UID2 UID3 Reply HR0 HR1 UID0 UID 1 UID2 UID3 datas

>>> CR95HFDLL_STCMD, 01 04 08 000000 6E567A00 A8

<<< 80 40 11 48 6E567A00

0002250000100E000313D1010F5402656E5573652043523935524620210000000000000000000000000000CCCCC

REM, Read ad08 00 UID0 UID 1 UID2 UID3

>>> CR95HFDLL_STCMD, 01 04 08 01 0800 6E567A00 A8

<<< 80 07 08 00 87C1 080000

REM, Write_E ad08 data 12 UID0 UID 1 UID2 UID3

>>> CR95HFDLL_STCMD, 01 04 08 53 0812 6E567A00 A8

<<< 80 07 08 12 14F2 080000

REM, Read ad08 00 UID0 UID 1 UID2 UID3

>>> CR95HFDLL_STCMD, 01 04 08 01 0800 6E567A00 A8

<<< 80 07 08 12 14F2 080000

REM, Write_NE ad08 data A5 UID0 UID 1 UID2 UID3

>>> CR95HFDLL_STCMD, 01 04 08 1A 08A5 6E567A00 A8

<<< 80 07 08 B7 B300 080000

REM, Read ad08 00 UID0 UID 1 UID2 UID3

>>> CR95HFDLL_STCMD, 01 04 08 01 0800 6E567A00 A8

```
<<< 80 07 08 B7 B300 080000
REM, Write_E ad08 data 00 UID0 UID 1 UID2 UID3
>>> CR95HFDLL_STCMD, 01 04 08 53 0800 6E567A00 A8
<<< 80 07 08 00 87C1 080000
REM, Read ad08 00 UID0 UID 1 UID2 UID3
>>> CR95HFDLL_STCMD, 01 04 08 01 0800 6E567A00 A8
<<< 80 07 08 00 87C1 080000
```

D.1.2 NFC Forum Tag Type 2

REM, CR95HF code example to support NFC Forum Tag Type 2 14443_A
REM, TEST INVENTORY then Read & Write in Memory

```
REM, Protocol select 14443A
>>> CR95HFDLL_STCMD, 01 02020200
<<< 0000

REM, Optimization of synchronization between digital and analog
inputs by adjusting TimerW value (default 0x52, min. 0x50, max.
0x60). Recommended value is 0x56 or 0x58 for NFC Forum Tag Type 2.
>>> CR95HFDLL_STCMD, 01 09043A005804
<<< 0000

REM, Recommended modulation and gain is 0xD1 or 0xD3 for NFC Forum
Tag Type 2.
>>> CR95HFDLL_STCMD, 01 0904680101D1
<<< 0000
>>> CR95HFDLL_ANTICOLSELECT123

----- ISO14443-A STARTING ANTICOLLISION ALGORITHM -----
ISO14443-A REQAreply ATQA
>>> CR95HFDLL_SENDRECV, 26 07
<<< 80 05 4400 280000
ISO14443-A ANTICOL 1
>>> CR95HFDLL_SENDRECV, 93 20 08
<<< 80 08 8804179F04 280000
ISO14443-A SELECT 1
>>> CR95HFDLL_SENDRECV, 93 70 8804179F04 28
<<< 80 06 04 DA17 080000
```



```
ISO14443-A ANTICOL 2
>>> CR95HFDLL_SENDRECV, 9520 08
<<< 80 08 7910000069 280000
ISO14443-A SELECT 2
>>> CR95HFDLL_SENDRECV, 9570 7910000069 28
<<< 80 06 00 FE51 080000

--> UID = 04179F10000069
--> TAG selected
----- ISO14443-A END OF ANTICOLLISION ALGORITHM -----

REM, READ @A5
>>> CR95HFDLL_SENDRECV, 300C 28
<<< 80 15 00000000FFFFFFFFFFFFFFFFFFFFFFFF F4CD 080000
REM, WRITE @0C data A5
>>> CR95HFDLL_SENDRECV, A20CA5A5A5A5 28
<<< 87 00 : Frame wait time out OR no tag
REM, READ @A5
>>> CR95HFDLL_SENDRECV, 300C 28
<<< 80 15 A5A5A5A5FFFFFFFFFFFFFFFFFFFFFFFF 84D8 080000
```

D.1.3 NFC Forum Tag Type 2 or 4: Using split frames to resolve collisions

```
REM, TEST ANTICOLISION 2 tags 14443_A
REM, CR95HF CONFIGURATION : ISO14443-A protocol
>>> CR95HFDLL_SELECT, 02000280
<<< 0000
REM, ISO14443-A : CONFIG
>>> CR95HFDLL_STCMD, 01 09043A005A04
<<< 0000
REM, ISO14443-A : INCREASE DEMOD GAIN
>>> CR95HFDLL_STCMD, 01 0904680101DF
<<< 0000

REM, Anticollision 2 tags
REM, Tag 1 --> UID = 044B744AEF2280
```

```
REM, Tag 2 --> UID = 043B114AEF2280
REM, Response When 2 tags are present NVB = nb Byte OK + nb bit OK
REM, Collision B8
REM, First Byte Coll 02 (3 eme Byte) (8804 ok)
REM, Index bit Coll 04 (5eme bit) => SN finish by 0 or 1
REM, set NVB = 45

REM, REQA Poll field with Two tags In operating volume
>>> CR95HFDLL_STCMD, 01 04022607
<<< 80 05 4403 280000

REM, Ant CL1 Collision Detection (NVB 20) none data on UID
REM, Response Flag F1=B8 F2=02 F3=04
REM, F1=B8 collision detected 8 bits significatifs in first byte of response
REM, F2=02 collision detected in 3rd response byte, index start at 0
REM, F3=04 collision detected on 5th bit, index start at 0
>>> CR95HFDLL_STCMD, 01 0403932008
<<< 80 08 88047B75B7 B80204

REM, Collision Management Usage of split frame with NVB = 45 4bytes OK + 5 lsb bit OK in next byte
REM, last bit (collision one) arbitrary fixed to select only one branch of UID tree
REM, padding of last byte with zeros as msb (tranmission lsb first) 0B
REM, command flag 45 usage of Split Frame (4) with 5 bits significatif in last byte
REM, uncomplete response byte is padded with 0 as lsb bits
REM, Response Flag F1=23 F2=00 F3=00
REM, F1=23, No collision
REM, 3 bit significatif (msb last received bits) in first response byte 40
REM, F2=00, not significant
REM, F3=00, not significant
>>> CR95HFDLL_STCMD, 01 0406934588040B45
```

CR95HF Examples of CR95HF command code to activate NFC Forum and ISO/IEC 15693 tags

```
<<< 80 06 4074B3 230000
REM,    Activation tag Highest branch
>>> CR95HFDLL_SENDRECV, 937088044B74B328
<<< 80 06 24D836 080000
REM,    Ant CL2
>>> CR95HFDLL_STCMD, 01 0403952008
<<< 80 08 4AEF228007 280000
REM,    Sel CL2 tag Highest branch
>>> CR95HFDLL_SENDRECV, 95704AEF22800728
<<< 80 06 20FC70 080000

REM,    ISO14443-A HLTA tag1 Highest branch
>>> CR95HFDLL_SENDRECV, 500028
<<< 8700 : Frame wait time out OR no tag

REM,    WUPA    Second tags In field
>>> CR95HFDLL_STCMD, 01 04025207
<<< 80 05 4403 280000
REM,    Ant CL1    Detection Collision second tag (No collision)
>>> CR95HFDLL_STCMD, 01 0403932008
<<< 80 08 88047B75B7 B80204
REM,    Activation tag lowest branch    043B114AEF2280
>>> CR95HFDLL_SENDRECV, 937088043B11A6789808
<<< 80 06 24D836 080000
REM,    Ant CL2
>>> CR95HFDLL_STCMD, 01 0403952008
<<< 80 08 4AEF228007 280000
REM,    Sel CL2 tag Highest branch
>>> CR95HFDLL_SENDRECV, 95704AEF22800728
<<< 80 06 20FC70 080000

REM,    ISO14443-A HLTA tag2 Lowest branch
>>> CR95HFDLL_SENDRECV, 500028
<<< 8700 : Frame wait time out OR no tag
```

```
REM, REQA no other tag In operating volume
>>> CR95HFDLL_STCMD, 01 04022607
<<< 8700
```

D.1.4 NFC Forum Tag Type 2

Communication using Parity Framing mode which is compliant with MIFARE® framing requirements.

REM, TEST Extract NDEF Message of NFC Tag Type 2 using Parity Framing mode option

```
REM, ISO14443-A protocol select
>>> 02000280
<<< 0000

REM, ISO14443-A configuration
>>> 09043A005A04
<<< 0000

REM, ISO14443-A: Increase modulation and gain
>>> 0904680101DF
<<< 0000
```

```
REM, REQA
>>> 04 02 26 07
<<< 80 05 4400 280000
```

```
REM, Ant CL1
>>> 04 03 93 20 08
<<< 80 08 8804CB8CCB 280000
```

```
REM, Sel CL1
>>> 04 08 9370 8804CB8CCB 28
<<< 80 06 04 DA17 080000
```

```
REM, Ant CL2
>>> 04 03 9520 08
<<< 80 08 1A432880F1 280000
```

```
REM, Sel CL2
>>> 04 08 9570 1A432880F1 28
<<< 80 06 00 FE51 080000
```

REM, All commands below are sent using Parity Framing mode option which defines the parity bit value coming with data byte.

REM, All commands byte including CRC are sent or received in format Data Byte Parity Byte.

REM, Special case occur when receiving single nibble for ACK (9004 0A 2400) or NAK (9004 0y 2400) where 'y' depends on error code.

REM, Row0 SN0 SN1 SN2 BCC0

REM, Read ROW0 option (cmd CRC1 addr CRC1 CRC2) Parity automatically included

REM, response Result code Length Data Status

>>> 04 05 **30 00 02 A8** 08

<<< **80 15** 04 CB 8C CB 1A 43 28 80 F1 48 00 00 E1 10 12 00 CF2F **080000**

REM, Read ROW0 option Parity Framing (cmd CRC1 addr CRC1 CRC2) Parity specify after each byte

REM, response Result code Length Data (data byte+parity byte) Status

>>> 04 09 **3080 0080 0200 A800** 18

<<< **80 27** 0400 CB00 8C00 CB00 1A00 4300 2880 8000 F100 4880 0080 0080 E180 1000 1280 0080 CF80 2F00 **080000**

REM, Read ROW0 option Parity Framing (cmd CRC1 addr CRC1 CRC2) with error in Parity

REM, Response Result code Length Data (data byte+parity byte) Status

REM, NACK

REM, CR95HFDLL_STCmd

REM, CR95HFDLL_STCmd

REM, Read ROW1_9 option Parity Framing (cmd CRC1 addr CRC1 CRC2) Parity specify after each byte REM

REM, Row1 SN3 SN4 SN5 SN6

>>> 04 09 **3080 0100 8B80 B900** 18

<<< **80 27** 1A00 4300 2880 8000 F100 4880 0080 0080 E180 1000 1280 0080 0100 0380 A080 1000 1880 7A00 **080000**

REM, Row2 BCC1 internal lock byte0 lock byte1

>>> 04 09 **3080 0200 1000 8B80** 18

<<< **80 27** F100 4880 0080 0080 E180 1000 1280 0080 0100 0380 A080 1000 4480 0380 0B00 D180 A580 4C00 **080000**

```
REM, Row3 CCFile Magic E1 Ver 10 MMY Size 12 Access 00
>>> 04 09 3080 0380 9980 9A80 18
<<< 80 27 E180 1000 1280 0080 0100 0380 A080 1000 4480 0380 0B00 D180
0100 0700 5580 0100 8880 1300 080000

REM, Row4 First TL (T01 Prop L 3 V)
>>> 04 09 3080 0400 2600 EE80 18
<<< 80 27 0100 0380 A080 1000 4480 0380 0B00 D180 0100 0700 5580 0100
7300 7480 2E80 6380 5A80 2A00 080000

REM, Row5 Second TLV NDEF MSG (T03 L 0B V www.st.com)
>>> 04 09 3080 0580 AF80 FF80 18
<<< 80 27 4480 0380 0B00 D180 0100 0700 5580 0100 7300 7480 2E80 6380
6F80 6D00 FE00 0080 3F80 8500 080000

REM, Row6 Second TLV NDEF MSG ( T V www.st.com)
>>> 04 09 3080 0680 3400 CD00 18
<<< 80 27 0100 0700 5580 0100 7300 7480 2E80 6380 6F80 6D00 FE00 0080
0080 FF80 0080 FF80 3F80 F680 080000

REM, Row7 Secobd TLV NDEF MSG (T V www.st.com)
>>> 04 09 3080 0700 BD80 DC00 18
<<< 80 27 7300 7480 2E80 6380 6F80 6D00 FE00 0080 0080 FF80 0080 FF80
4500 7300 7300 6100 4880 CB00 080000

REM, Row8 Third TLV Terminator (T V FE 00)
>>> 04 09 3080 0800 4A00 2480 18
<<< 80 27 6F80 6D00 FE00 0080 0080 FF80 0080 FF80 4500 7300 7300 6100
0080 FF80 0080 FF80 F080 4B80 080000

REM, Row9 Read Scratch pad
>>> 04 09 3080 0980 C380 3580 18
<<< 80 27 0080 FF80 0080 FF80 4500 7300 7300 6100 0080 FF80 0080 FF80
4500 4600 2000 5400 9A80 4880 080000

REM, Write ROW9 option Parity Framing (cmd CRC1 addr CRC1 CRC2)
Parity specify after each byte
```

REM, Response Result code Length Data (data byte+parity byte) Status

REM, Row9 Write Scratch pad (ACK)

>>> 04 11 **A200 0980 AA80 5580 AA80 5580 2900 7D80** 18

<<< **90 04** 0A 240000

REM, Row9 Read Scratch pad

>>> 04 09 **3080 0980 C380 3580** 18

<<< **80 27** AA80 5580 AA80 5580 4500 7300 7300 6100 0080 FF80 0080 FF80
4500 4600 2000 5400 1780 B480 **080000**

REM, Row9 Write Scratch pad (ACK)

>>> 04 11 **A200 0980 0080 FF80 0080 FF80 C800 2780** 18

<<< **90 04** 0A 240000

REM, Row9 Read Scratch pad

>>> 04 09 **3080 0980 C380 3580** 18

<<< **80 27** 0080 FF80 0080 FF80 4500 7300 7300 6100 0080 FF80 0080 FF80
4500 4600 2000 5400 9A80 4880 **080000**

REM, Select Sector 0 (NACK)

>>> 04 09 **C200 FF80 C200 E880** 18

<<< **90 04** 00 240000

BREAK

>>> CR95HFDLL_RESET_SPI

<<< 8000

>>> CR95HFDLL_ECHO

<<< 5500

>>> CR95HFDLL_IDN

<<< **00 0F 4E46 4320 4653 324A 4153 5434** 002ACE

D.1.5 NFC Forum Tag Type 4A

**** CR95HF code example to support NFC Forum Tag Type 4A (14443-A)
& NDEF message

REM, 14443B (CR95HF Protocol Selection 14443_A)

REM, first Byte 01 in CR95HFDLL_STCMD is only requested by CR95HF
Development SW

```

***** CR95HF setting to support extended Frame Waiting Time
*****
>>> CR95HFDLL_STCMD, 01 020402000180
<<< 0000
REM, Optimization of synchronization between digital and analog
inputs by adjusting TimerW value (default 0x52, min. 0x50, max.
0x60). Recommended value is 0x56 or 0x58 for NFC Forum Tag Type 1
(Topaz).
>>> CR95HFDLL_STCMD, 01 09043A005804
<<< 0000
REM, Recommended modulation and gain is 0xD1 or 0xD3 for NFC Forum
Tag Type 1 (Topaz).
>>> CR95HFDLL_STCMD, 01 0904680101D1
<<< 0000
REM, last Byte x7 or x8 in CR95HFDLL_SENDRECV command number of
bit in the 14443 _Type A frame
>>> CR95HFDLL_ANTICOLSELECT123

----- ISO14443-A STARTING ANTICOLLISION ALGORITHM -----
ISO14443-A REQA
>>> CR95HFDLL_SENDRECV, 26 07
<<< 80 05 0400 280000
ISO14443-A ANTICOL 1
>>> CR95HFDLL_SENDRECV, 9320 08
<<< 80 08 08192D A29E 280000
ISO14443-A SELECT 1
>>> CR95HFDLL_SENDRECV, 937008192DA29E 28
<<< 80 06 20 FC70 080000
--> UID = 192DA29E , TAG selected
----- ISO14443-A END OF ANTICOLLISION ALGORITHM -----

*** ISO14443A_4 RATS/ATS (bit rate capability/FDT/CID usage)
>>> CR95HFDLL_SENDRECV, E050 28
<<< 80 0A 057833B003 A0F8 080000

***** ISO14443A_4 PPS (Protocol parameter data rate)
>>> CR95HFDLL_SENDRECV, D01100 28

```

<<< 80 06 D0 7387 080000

** ISO14443_4 APDU (command & reply are using Iblock format,
Prolog Information (APDU) Epilog)

*** 7816_ APDU format (Class Instruction, Param , Length cmd data
Length expeted)

*** last byte 28 is a control byte to request CR95HF to
automatically happen CRC as Epilog

*** In response first 2 Byte 80 xx and last three bytes 08 0000 are
CR95HF's control bytes

*** Detect & Access NDEF Message

*** Select Application by name

>>> CR95HFDLL_SENDRECV, 02 00 A4040007D2760000850100 28

<<< 80 08 02 9000 F109 080000

***** Select CC File by name

>>> CR95HFDLL_SENDRECV, 03 00 A4000002E103 28

<<< 80 08 03 9000 2D53 080000

***** ReadBinary CC (offset Le)

>>> CR95HFDLL_SENDRECV, 02 00 B000000F 28

<<< 80 17 02 000F100FF00FF0406000100FF0000 9000 B755 080000

***** Select NDEF MSG by Identifier 0001

>>> CR95HFDLL_SENDRECV, 03 00 A40000020001 28

<<< 80 08 03 9000 2D53 080000

***** ReadBinary NDEF MSG (MSG Length offset 00 2
bytes)

>>> CR95HFDLL_SENDRECV, 02 00 B0000002 28

<<< 80 0A 02 0015 9000 ABB3 080000

***** Select NDEF File by name

>>> CR95HFDLL_SENDRECV, 03 00 A40000020001 28

<<< 80 08 03 9000 2D53 080000

***** ReadBinary NDEF (MSG offset 02 , 20 Bytes)

```
>>> CR95HFDLL_SENDRECV, 02 00 B0000215 28
<<< 80 1D 02D101115402656E4D32344C52313620747970652034 9000 25C5 080000
```

```
***      Header D1 type 01 Payload 11 type 54 status 02 english 656E
, MSG : M24LR16 type
```

D.2 ISO/IEC 14443 Type B

D.2.1 NFC Forum Tag Type 4B

```
**** CR95HF code example to support NFC Forum Tag Type 4B (14443-B)
& NDEF message

REM, Check CR95HF setting & Protocol selection

REM, FIELD OFF

REM, first Byte 01 in CR95HFDLL_STCMD is only requested by CR95HF
Development SW

>>> CR95HFDLL_STCMD, 01 02020000
<<< 0000

REM, 14443B (CR95HF PROTOCOL Selection 14443_B

>>> CR95HFDLL_STCMD, 01 020403010180
<<< 0000

REM, 14443B Optimization CR95HF Analog Configuration for 144443
(0x30)

>>> CR95HFDLL_STCMD, 01 090468010130
<<< 0000

REM, Access to NFC FORUM TAG Type 4B

REM, REQB 0x 050000 + CRC_B (APf AFI Param (slot0))

REM, Reply ATQB 0x50 4Bytes 4 Bytes 3 Bytes + CRC_B (PUPI AppliData
Protocol Info)

REM, Reply from CR95HF 80 0F 50AABBCCDD30ABAB010081E1AE00 00

REM, 80 response OK, 0F nb byte response including tag reply and the
ultimate CR95HF status byte 00 (reply OK)

REM, Tag reply 50AABBCCDD30ABAB010081E1AE00

REM, Response code 50

REM, Pupi AABBCCDD

REM, AFI 30 access control
```

CR95HF Examples of CR95HF command code to activate NFC Forum and ISO/IEC 15693 tags

```
REM, CRC_B(AID) ABAB
REM, Nb Appli (1) 01
REM, Prot Info byte1 00 (106 Kbps both direction)
REM, Prot Info byte 2 81( frame max 256 Bytes ISO compliant)
0081E1AE0000
REM, Prot Info byte 3 E1 (Max frame wait time 4.9 ms Appli
proprietary CID supported)
REM, CRC_B AE00

REM, 14443_3
REM, REQB ....
>>> CR95HFDLL_STCMD, 01 04 03 050000
<<< 80 0F 50AABCCDD30ABAB010081E1 AE00 00

REM, ATTRIB 0x1D PUPI 1byte 1byte 1byte 1 byte + CRC_B (1D
Identifier Param1 Param2 Param3 Param4)
REM, Param1 00 use default TR0 TR1 use EOF
REM, Param2 07 max frame size 106 Kbps Up & Dwn link
REM, Param3 01 ISO14443 compliant
REM, Param4 08 CID (8) card Identifier
REM, reply CR95HF 80 04 18EBC3 00
REM, 80 response OK 04 nb byte response including ultimate byte
00 CR95HF reply OK
REM, Reply 10F9E0 coefBufferLength 1 CID 1 + CRC_B

REM, ATTRIB ....CID0
>>> CR95HFDLL_STCMD, 01 04 09 1D AABCCDD00070100
<<< 80 04 10 F9E0 00

REM, 14443_4 , CID not used
REM, APDU for NDEF management
REM, command format (INF) CLA INS P1 P2 Lc(optional)
Data(optional)
REM, Response (optional ): body (optional) Sw1 sw2
REM, Block Format Prolog INFO Epilog ( 02 [CID] [NAD] [INF] CRC_B
)
```

REM, Sequence lecture NDEF (for all following commands CRC_B is automatically appends by CR95HF)

REM, Select application suivant la version du tag (100)

>>> CR95HFDLL_SENDRECV, 02 00 A4 040007D2760000850100

<<< 80 06 029000296A 00

REM, response 90 00 ok

REM, response 6A 82 application not found

REM, Select CC

>>> CR95HFDLL_SENDRECV, 03 00 A4 0000 02 E103

<<< 80 06 03 9000 F530 00

REM, Read CC

>>> CR95HFDLL_SENDRECV, 02 00 B0 0000 0F

<<< 80 15 02 000F1000FF00FF0406000110020000 9000 E7FA 00

REM, Select Ndef 0001

>>> CR95HFDLL_SENDRECV, 03 00 A4 0000 02 0001

<<< 80 06 03 9000 F530 00

REM, Read Msg Length

>>> CR95HFDLL_SENDRECV, 02 00 B0 0000 02

<<< 80 08 02 0013 9000 53AA 00

REM, Select Ndef 0001

>>> CR95HFDLL_SENDRECV, 03 00 A4 0000 02 0001

<<< 80 06 03 9000 F530 00

REM, Read Message

>>> CR95HFDLL_SENDRECV, 02 00 B0 0002 13

<<< 80 19 02 D1010F5402656E557365204352393548462021 9000 8571 00

D.3 ISO/IEC 18092

D.3.1 NFC Forum Tag Type 3

REM, CR95HF code example to support NFC Forum Tag Type 3

REM, TEST INVENTORY ISO/IEC 18092

REM, RFOFF

>>> CR95HFDLL_STCMD, 01 02020000

<<< 0000

```
REM, Select Protocol 14443C
>>> CR95HFDLL_STCMD, 01 02020451
<<< 0000
REM, ISO/IEC 18092 New Modulation and Gain 0x50
>>> CR95HFDLL_STCMD, 01 090468010150
<<< 0000
REM, ISO/IEC 18092 Enable AutoDetect Filter to synchronize NFC Forum Tag Type 3 with
CR95HF device
>>> CR95HFDLL_STCMD, 01 09040A0102A1
<<< 0000
REM, REQC 00 FFFF 00 00 (command code System code No request slot 0)
REM, ATQC 80 12 01 010102148E0DB413 (Manuf ID) 100B4B428485D0FF (Manuf
Parameter)
>>> CR95HFDLL_STCMD, 01 04 05 00FFFF0000
<<< 80 12 01 010102148E0DB413 100B4B428485D0FF 00
```

D.4 ISO/IEC 15693

D.4.1 ISO/IEC 15693 tag

```
REM, Test Tag ISO/IEC 15693 (LR family)
REM, Protocol Selection Up link Ask 30% coding 1/4
REM, Down link Single Sub carrier High data rate
REM, Inventory One Slot
REM, Command Protocol Select 02 02 01 05

REM, Protocol Selection
>>> CR95HFDLL_STCMD, 01 02020105
<<< 0000

REM, Modification of IndexMod & Gain in Analog Value register
@69_index1 0x50
>>> CR95HFDLL_STCMD, 01 090468010150
<<< 0000

REM, Inventory 1 Slot
>>> CR95HFDLL_STCMD, 01 0403 260100
```

```
<<< 80 0D 0000B7100128B42102E0 66CC 00

REM, GetSystem Info
REM, Flags, UID E00221B4280110B7 DSFID 00 AFI 00 MemorySize 3F
BlockSize 03 IC Reference 21

>>> CR95HFDLL_SENDRECV, 022B
<<< 80 12 00 0F B7100128B42102E0000003F03 21 DFB0 00
REM, Test Tag ISO/IEC 15693 (Dual family)
REM, Protocol Selection Up link Ask 30% coding 1/4
REM, Down link Single Sub carrier High data rate
REM, Inventory 1 Slot
REM, Command Protocol Select 02 02 01 05

REM, Protocol Selection
>>> CR95HFDLL_STCMD, 01 02020105
<<< 0000

REM, Modification of IndexMod & Gain in Analog Value register
@69_index1 0x50
>>> CR95HFDLL_STCMD, 01 090468010150
<<< 0000

REM, Inventory 1 Slot
>>> CR95HFDLL_STCMD, 01 0403 260100
<<< 80 0D 00FF07062092132C02E0 3D22 00

REM, GetSystem Info
REM, Flags ,UID E0022C1392200607 DSFID FF AFI 00 MemorySize 07FF
BlockSize 03 IC Reference 2C

>>> CR95HFDLL_SENDRECV, 0A2B
<<< 80 13 00 0F 07062092132C02E0 FF 00 FF07 03 2C 984D 00
```

Revision history

Table 40. Document revision history

Date	Revision	Changes
30-Mar-2011	1	Initial release.
08-Sep-2011	2	Removed SSI_2 pin.
26-Oct-2011	3	Upgraded document from Preliminary Data to full Datasheet.
28-Oct-2011	4	Updated device revision information. Added <i>Section 6.2: DC characteristics on page 40</i> and updated <i>Section 6.3: Power consumption characteristics on page 40</i> .
06-Jan-2012	5	Updated <i>Table 12: List of <Parameters> values for the ProtocolSelect command for different protocols on page 18</i> , <i>Table 17: Idle command description on page 28</i> and <i>Section 5.6.5: Tag detection calibration procedure</i> . Updated <i>Section 6.3: Power consumption characteristics</i> , <i>Section 6.4: SPI characteristics</i> and <i>Section 6.5: RF characteristics</i> . Updated <i>Appendix B: Example of tag detection calibration process</i> and <i>Appendix C: Example of tag detection command using results of tag detection calibration</i> .
04-May-2012	6	Updated <i>Table 3: CR95HF operating modes and states on page 8</i> . Updated response to IDN command in <i>Section 5.3</i> . Added additional features in <i>Section 5.8: Write Register (WrReg) command (0x09) description</i> . Added optional parameter to increase maximum waiting time in NFC Forum Tag Type 3. Updated <i>Section 6.3: Power consumption characteristics</i> and added enhanced command for reducing consumption.
07-Jun-2012	7	Updated <i>Section 6.3: Power consumption characteristics</i> and enhanced command (HF2RF bit) for reducing consumption.
24-Jul-2012	8	Changed Response example to Command example in <i>Table 14: List of <Data> Send values for the SendRecv command for different protocols</i> . Updated <i>Table 2: CR95HF pin descriptions on page 6</i> .
09-Jun-2014	9	Updated <i>Section 3.2: Startup sequence</i> and <i>Table 28: Absolute maximum ratings on page 39</i> .
10-Oct-2014	10	Corrected reporting of 4-bit frames in ISO/IEC 14443-A mode. Internal data exchange buffer is now 528 bytes. Now able to directly manage the value of Parity bit included in a standard ISO/IEC 14443-A frame. Added optional parameters for use in Protocol Select command. Mains supply extended to 5V range. Added enhanced error code list.

IMPORTANT NOTICE – PLEASE READ CAREFULLY

STMicroelectronics NV and its subsidiaries ("ST") reserve the right to make changes, corrections, enhancements, modifications, and improvements to ST products and/or to this document at any time without notice. Purchasers should obtain the latest relevant information on ST products before placing orders. ST products are sold pursuant to ST's terms and conditions of sale in place at the time of order acknowledgement.

Purchasers are solely responsible for the choice, selection, and use of ST products and ST assumes no liability for application assistance or the design of Purchasers' products.

No license, express or implied, to any intellectual property right is granted by ST herein.

Resale of ST products with provisions different from the information set forth herein shall void any warranty granted by ST for such product.

ST and the ST logo are trademarks of ST. All other product or service names are the property of their respective owners.

Information in this document supersedes and replaces information previously supplied in any prior versions of this document.

© 2014 STMicroelectronics – All rights reserved