

**Quad Differential Comparator**

# LM339PC

## Description

The LM339PC consists of four independent voltage comparators, designed specifically to operate from a single power over a wide voltage range.

## Features

- Single or dual supply operation.
- Wide operating supply range( $V_{CC}=2V\sim 36V$ ).
- Input common-mode voltage includes ground.
- Low supply current drain  $I_{CC}=0.8mA$ (typical).
- Low input bias current  $I_{bias}=25nA$ (typical).
- Output compatible with TTL, DTL and CMOS logic system.

## Pin Configurations

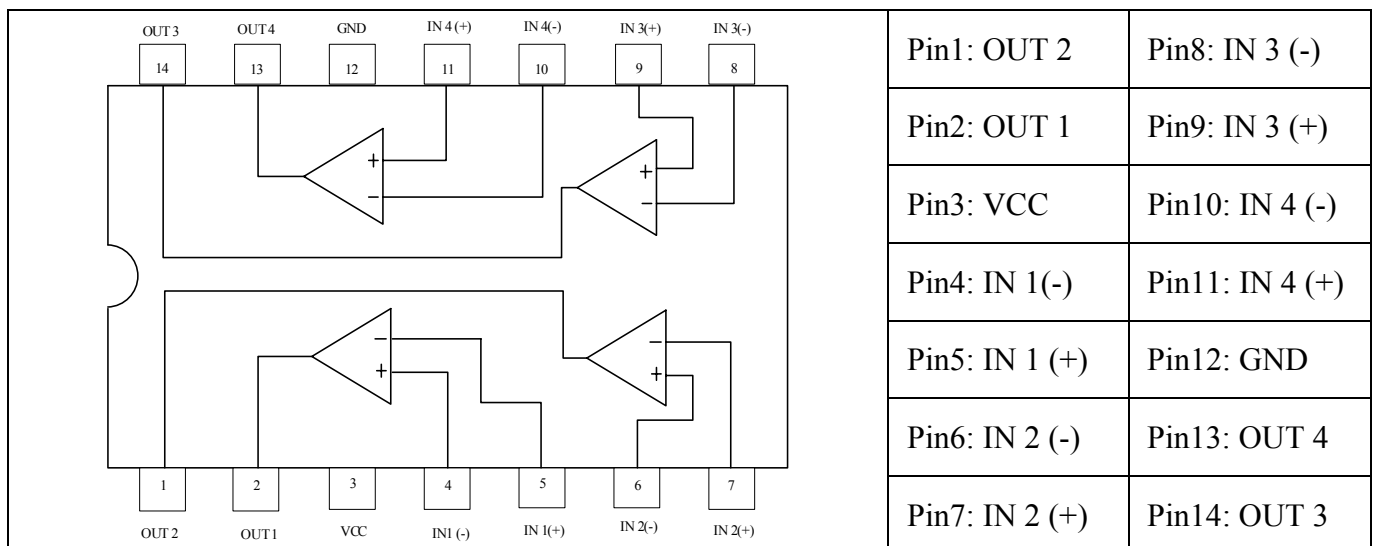



### Absolute Maximum Rating

Parameter	Symbol	Value	Unit
Supply Voltage	V <sub>CC</sub>	±18 or 36	V
Differential Input Voltage	V <sub>IDiff</sub>	36	V
Input Voltage	V <sub>I</sub>	-0.3 ~ 36	V
Power Dissipation	P <sub>D</sub>	570	mW
Operating Temperature	T <sub>opr</sub>	0 ~ +70	°C
Storage Temperature	T <sub>stg</sub>	-65 ~ +150	°C

### Electrical Characteristics (V<sub>CC</sub>=5V, T<sub>a</sub>=25°C, all voltage referenced to ground unless otherwise specified.)

Parameter	Test Condition	Symbol	Min.	Typ.	Max.	Unit
Input Offset Voltage	V <sub>CC</sub> =5~30V, V <sub>IC</sub> =V <sub>ICR(min)</sub> V <sub>O</sub> =1.4V, R <sub>S</sub> =0	V <sub>IO</sub>	-	±2	±5	mV
Input Offset Current	V <sub>O</sub> =1.4V	I <sub>IO</sub>	-	±5	±50	nA
Input Bias Current	V <sub>O</sub> =1.4V	I <sub>BIAS</sub>	-	-25	-250	nA
Input Common-Mode Voltage Range (Note 1)		V <sub>ICR</sub>	0	-	V <sub>CC</sub> -1.5	V
Supply Current	R <sub>L</sub> =∞, V <sub>CC</sub> =5V	I <sub>CC</sub>	-	0.8	2.0	mA
	R <sub>L</sub> =∞, V <sub>CC</sub> =30V (full range)		-	-	2.5	mA
Large Signal Differential Voltage Amplification	V <sub>CC</sub> =15V, V <sub>O</sub> =1.4V~11.4V R <sub>L</sub> ≥15kΩ to V <sub>CC</sub>	A <sub>VD</sub>	50	200	-	V/mV
Response Time	TTL level input step (Note 2) V <sub>RL</sub> =5V, R <sub>L</sub> =5.1kΩ, C <sub>L</sub> =15pF	t <sub>res</sub>	-	350	-	ns
	100mV input step with 5mV overdrive (Note 2) V <sub>RL</sub> =5V, R <sub>L</sub> =5.1kΩ, C <sub>L</sub> =15pF		-	1400	-	ns
Low-level Output Current	V <sub>IN(-)</sub> =1V, V <sub>IN(+)</sub> =0V, V <sub>OL</sub> =1.5V	I <sub>OL</sub>	6	18	-	mA
Low-level Output Voltage	V <sub>IN(-)</sub> =1V, V <sub>IN(+)</sub> =0V, I <sub>OL</sub> =4mA	V <sub>OL</sub>	-	150	400	mV
High-level Output Current	V <sub>IN(+)</sub> =1V, V <sub>IN(-)</sub> =0V, V <sub>OH</sub> =5V V <sub>OH</sub> =30V (full range)	I <sub>OH</sub>	-	0.1	-	nA
			-	-	1.0	μA

Note : 1. The voltage at either input or common-mode should not be allowed to negative by more than 0.3V. The upper end of the common-mode voltage range is V<sub>CC</sub>-1.5V, but either or both input can go to 30V without damage.

2. The response time specified is the interval between the input step function and instant when the output crosses 1.4V.

### Block Diagram

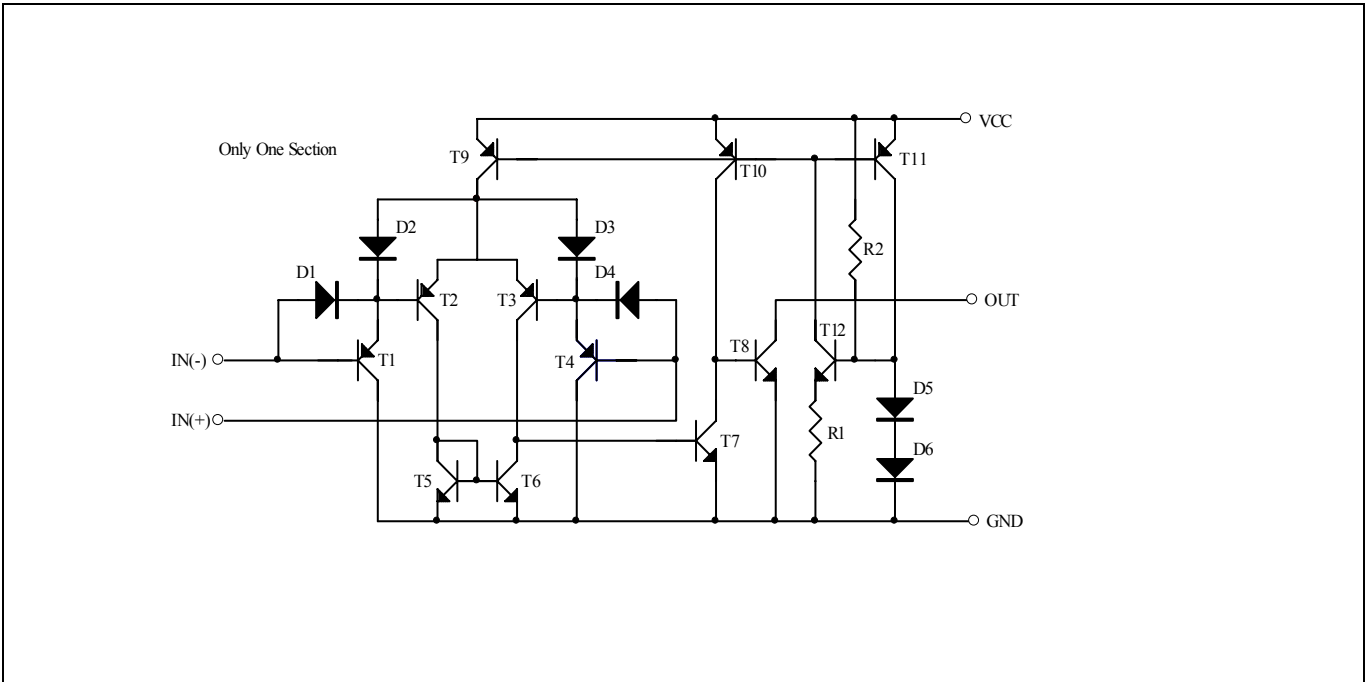

**Typical Characteristics**

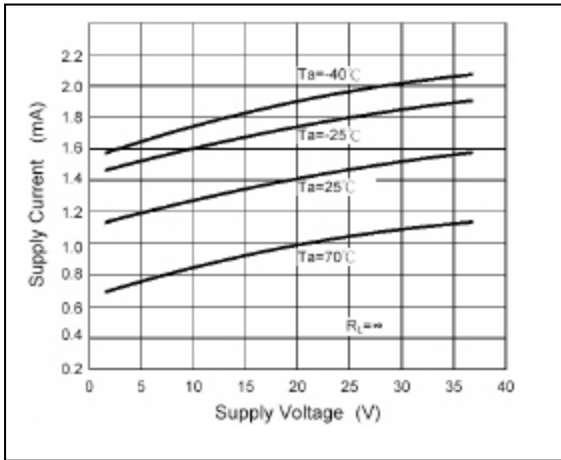

Fig. 1 Supply Current

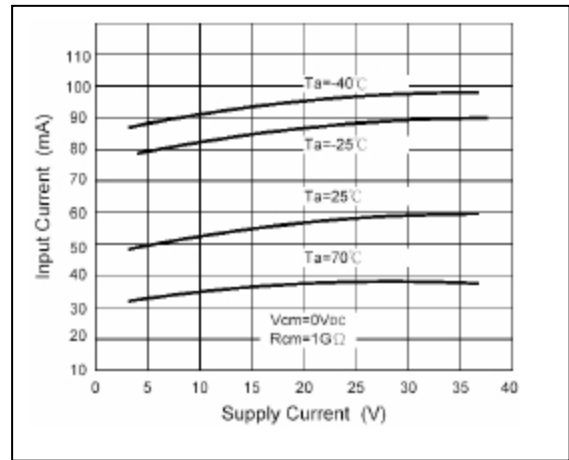

Fig. 2 Input Current

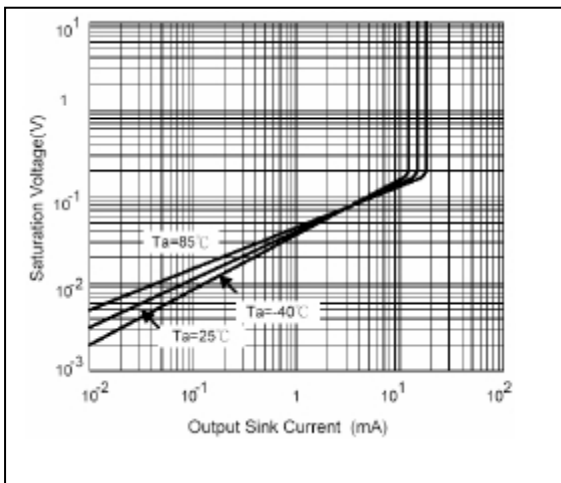

Fig. 3 Output Saturation Voltage

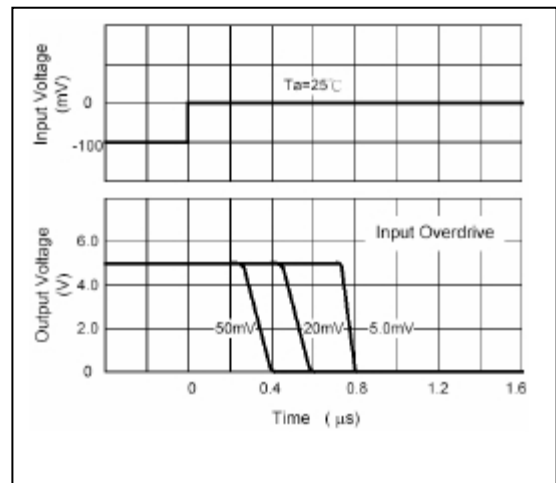

Fig. 4 Response Time for Various Input Overdrive Negative Transition

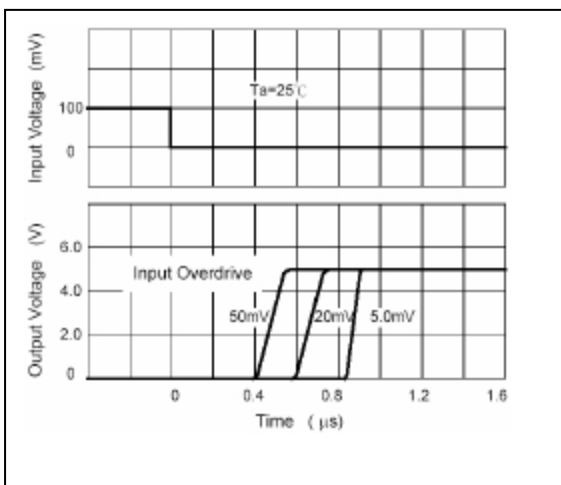

Fig. 5 Response Time for Various Input Overdrive Positive Transition

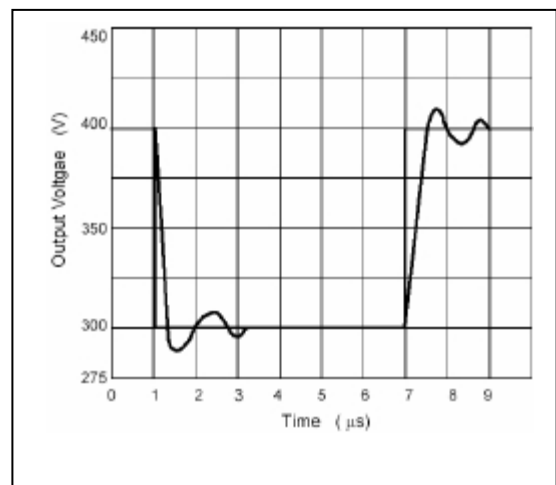

Fig. 6 Voltage Follower Pulse Response (Small Signal)

**Typical Characteristics(Cont.)**

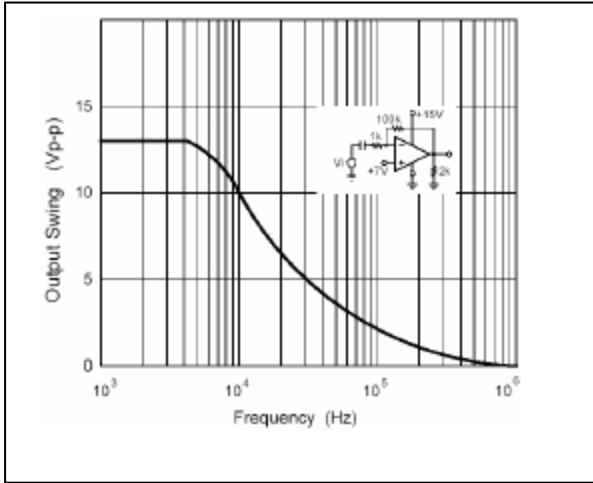

Fig. 7 Large Signal Frequency Response

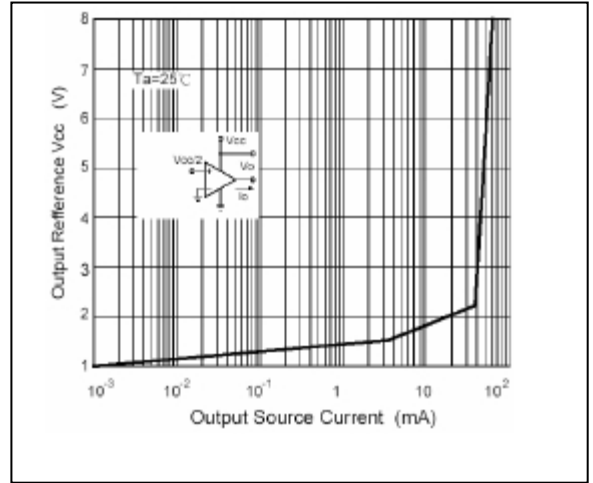

Fig. 8 Output Characteristics Current Sourcing

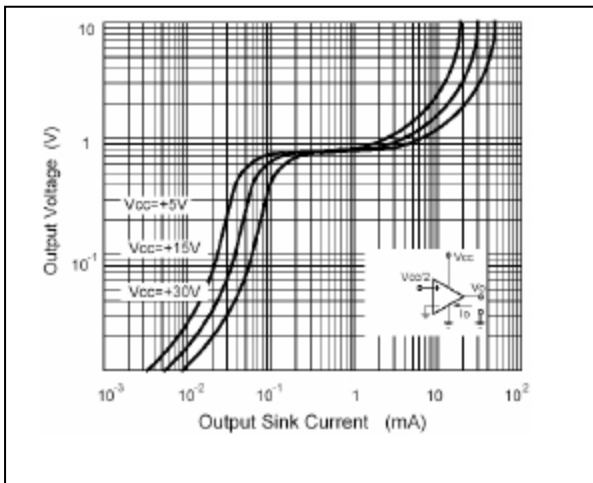

Fig. 9 Output Characteristics Current Sinking

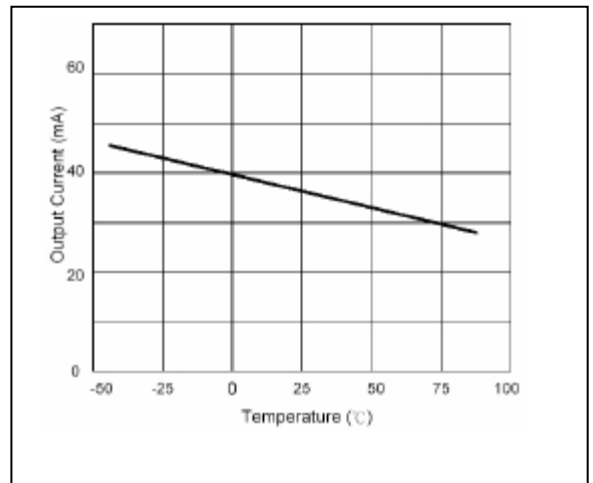
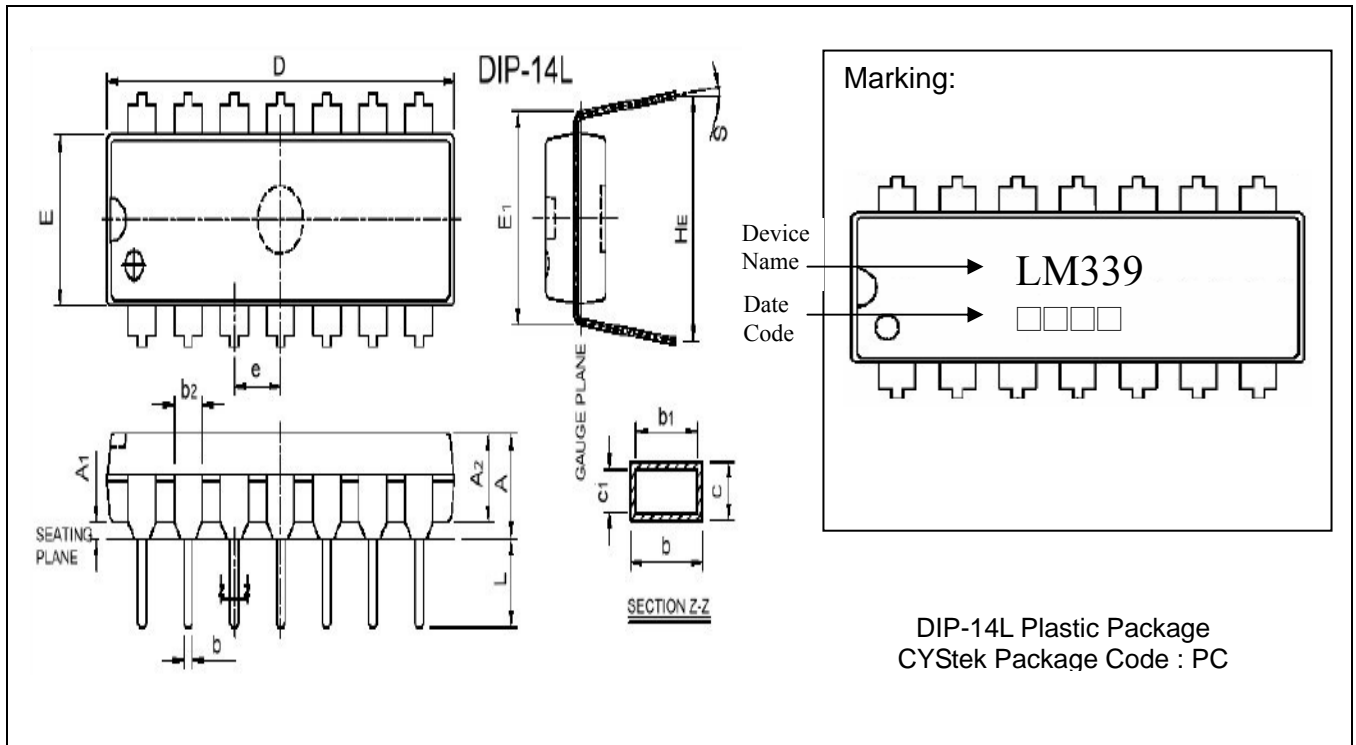

Fig. 10 Current Limiting

**DIP-14L Dimension**



DIM	Millimeters		Inches		DIM	Millimeters		Inches	
	Min.	Max.	Min.	Max.		Min.	Max.	Min.	Max.
A	-	5.334	-	0.210	D	18.920	19.690	0.745	0.775
A1	0.381	-	0.015	-	E	6.096	6.604	0.240	0.260
A2	3.175	3.429	0.125	0.135	E1	7.493	8.001	0.295	0.315
b	0.406	0.508	0.016	0.020	e	2.413	2.667	0.095	0.105
b1	0.356	0.508	0.014	0.020	HE	8.509	9.525	0.335	0.375
b2	1.270	1.778	0.050	0.070	L	3.175	3.683	0.125	0.145
c	0.203	0.356	0.008	0.014	S	0°	15°	0°	15°
c1	0.203	0.279	0.008	0.011					

Notes : 1.Controlling dimension : millimeters.  
 2.Maximum lead thickness includes lead finish thickness, and minimum lead thickness is the minimum thickness of base material.  
 3.If there is any question with packing specification or packing method, please contact your local CYStek sales office.

**Material :**

- Mold Compound : Epoxy resin family, flammability solid burning class:UL94V-0.

**Important Notice:**

- All rights are reserved. Reproduction in whole or in part is prohibited without the prior written approval of CYStek.
- CYStek reserves the right to make changes to its products without notice.
- CYStek **semiconductor products are not warranted to be suitable for use in Life-Support Applications, or systems.**
- CYStek assumes no liability for any consequence of customer product design, infringement of patents, or application assistance.