

MOTOROLA
SEMICONDUCTOR
TECHNICAL DATA

T-11-23

Zener Overvoltage Transient Suppressors

... the 1.5SMC6.8 series is designed to protect voltage sensitive components from high voltage, high energy transients. They have excellent clamping capability, high surge capability, low zener impedance and fast response time. The 1.5SMC6.8 series is supplied in Motorola's exclusive, cost-effective, highly reliable Surmetic axial leaded package and is ideally suited for use in communication systems, numerical controls, process controls, medical equipment, business machines, power supplies and many other industrial/consumer applications.

- Standard Zener Voltage Range — 6.8 to 200 V
- Peak Power — 1500 Watts @ 1.0 ms
- Maximum Clamp Voltage @ Peak Pulse Current
- Low Leakage < 5.0 μ A Above 10 V
- Maximum Temperature Coefficient Specified
- Available in Tape and Reel

Mechanical Characteristics:

CASE: Void-free transfer-molded, thermosetting plastic

FINISH: All external surfaces are corrosion resistant and leads are readily solderable and weldable

POLARITY: Cathode indicated by molded polarity notch. When operated in zener mode, will be positive with respect to anode.

MOUNTING POSITION: Any

LEADS: Modified L-Bend providing more contact area to bond pads

MAXIMUM CASE TEMPERATURE FOR SOLDERING PURPOSES: 230°C for 10 seconds

1.5SMC6.8,A
thru
1.5SMC200,A

PLASTIC SURFACE MOUNT
ZENER OVERVOLTAGE
TRANSIENT SUPPRESSORS
6.8-200 VOLTS
1500 PEAK POWER
5.0 WATTS STEADY STATE



CASE 403-01

OUTLINE DIMENSIONS

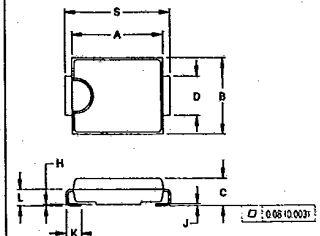

- NOTES:
1. DIMENSIONING AND TOLERANCING PER ANSI Y14.5M, 1982.
2. CONTROLLING DIMENSION: INCH.

DIM	MILLIMETERS		INCHES	
	MIN	MAX	MIN	MAX
A	6.74	6.98	0.265	0.275
B	5.72	5.96	0.225	0.235
C	2.01	2.26	0.079	0.089
D	2.88	3.12	0.113	0.123
H	0.013	0.101	0.0005	0.0040
J	0.11	0.25	0.004	0.010
K	1.02	1.27	0.040	0.050
L	1.17	1.42	0.046	0.056
S	7.80	8.05	0.307	0.317

MAXIMUM RATINGS

Rating	Symbol	Value	Unit
Peak Power Dissipation (1) @ $T_L \leq 25^\circ\text{C}$	P _{PK}	1500	Watts
Steady State Power Dissipation @ $T_L \leq 75^\circ\text{C}$ Derated above $T_L = 75^\circ\text{C}$	P _D	5.0 50	Watts mW/°C
Forward Surge Current (2) @ $T_A = 25^\circ\text{C}$	I _{FSM}	200	Amps
Operating and Storage Temperature Range	T _J , T _{stg}	-65 to +175	°C

- NOTES: 1. Derated above $T_A = 25^\circ\text{C}$ per Figure 2.
2. 1/2 Square Wave (or equivalent), PW = 8.3 ms, Duty Cycle = 4 Pulses per minute maximum.



MOTOROLA

T-11-23

ELECTRICAL CHARACTERISTICS (T_A = 25°C unless otherwise noted) V_F = 3.5 V max, I_F** = 100 A for all types.

Device	Breakdown Voltage				Working Peak Reverse Voltage V _{RWM} Volts	Maximum Reverse Leakage @ V _{RWM} I _R μA	Maximum Reverse Surge Current I _{RSM} † Amps	Maximum Reverse Voltage @ I _{RSM} (Clamping Voltage) V _{RSM} Volts	Maximum Temperature Coefficient of V _{BR} %/°C	Device Marking
	V _{BR} @ I _T Volts									
	Min	Nom	Max	mA						
1.5SMC6.8	6.12	6.8	7.48	10	5.50	1000	139	10.8	0.057	V68
1.5SMC6.8A	6.45	6.8	7.14	10	5.80	1000	143	10.5	0.057	A68
1.5SMC7.5	6.75	7.5	8.25	10	6.05	500	128	11.7	0.061	V75
1.5SMC7.5A	7.13	7.5	7.88	10	6.40	500	132	11.3	0.061	A75
1.5SMC8.2	7.38	8.2	9.02	10	6.63	200	120	12.5	0.065	V82
1.5SMC8.2A	7.79	8.2	8.61	10	7.02	200	124	12.1	0.065	A82
1.5SMC9.1	8.19	9.1	10.0	1.0	7.37	50	109	13.8	0.068	V91
1.5SMC9.1A	8.65	9.1	9.55	1.0	7.78	50	112	13.4	0.068	A91
1.5SMC10	9.00	10	11.0	1.0	8.10	10	100	15.0	0.073	1V0
1.5SMC10A	9.50	10	10.5	1.0	8.55	10	103	14.5	0.073	1A0
1.5SMC11	9.90	11	12.1	1.0	8.92	5.0	93.0	16.2	0.075	1V1
1.5SMC11A	10.5	11	11.6	1.0	9.40	5.0	96.0	15.6	0.075	1A1
1.5SMC12	10.8	12	13.2	1.0	9.72	5.0	87.0	17.3	0.078	1V2
1.5SMC12A	11.4	12	12.6	1.0	10.2	5.0	90.0	16.7	0.078	1A2
1.5SMC13	11.7	13	14.3	1.0	10.5	5.0	79.0	19.0	0.081	1V3
1.5SMC13A	12.4	13	13.7	1.0	11.1	5.0	82.0	18.2	0.081	1A3
1.5SMC15	13.5	15	16.5	1.0	12.1	5.0	68.0	22.0	0.084	1V5
1.5SMC15A	14.3	15	15.8	1.0	12.8	5.0	71.0	21.2	0.084	1A5
1.5SMC16	14.4	16	17.6	1.0	12.9	5.0	64.0	23.5	0.086	1V6
1.5SMC16A	15.2	16	16.8	1.0	13.6	5.0	67.0	22.5	0.086	1A6
1.5SMC18	16.2	18	19.8	1.0	14.5	5.0	56.5	26.5	0.088	1V8
1.5SMC18A	17.1	18	18.9	1.0	15.3	5.0	59.5	25.2	0.088	1A8
1.5SMC20	18.0	20	22.0	1.0	16.2	5.0	51.5	29.1	0.090	2V0
1.5SMC20A	19.0	20	21.0	1.0	17.1	5.0	54.0	27.7	0.090	2A0
1.5SMC22	19.8	22	24.2	1.0	17.8	5.0	47.0	31.9	0.092	2V2
1.5SMC22A	20.9	22	23.1	1.0	18.8	5.0	49.0	30.6	0.092	2A2
1.5SMC24	21.6	24	26.4	1.0	19.4	5.0	43.0	34.7	0.094	2V4
1.5SMC24A	22.8	24	25.2	1.0	20.5	5.0	45.0	33.2	0.094	2A4
1.5SMC27	24.3	27	29.7	1.0	21.8	5.0	38.5	39.1	0.096	2V7
1.5SMC27A	25.7	27	28.4	1.0	23.1	5.0	40.0	37.5	0.096	2A7
1.5SMC30	27.0	30	33.0	1.0	24.3	5.0	34.5	43.5	0.097	3V0
1.5SMC30A	28.5	30	31.5	1.0	25.6	5.0	36.0	41.4	0.097	3A0
1.5SMC33	29.7	33	36.3	1.0	26.8	5.0	31.5	47.7	0.098	3V3
1.5SMC33A	31.4	33	34.7	1.0	28.2	5.0	33.0	45.7	0.098	3A3
1.5SMC36	32.4	36	39.6	1.0	29.1	5.0	29.0	52.0	0.099	3V6
1.5SMC36A	34.2	36	37.8	1.0	30.8	5.0	30.0	49.9	0.099	3A6
1.5SMC39	35.1	39	42.9	1.0	31.6	5.0	26.5	56.4	0.100	3V9
1.5SMC39A	37.1	39	41.0	1.0	33.3	5.0	28.0	53.9	0.100	3A9
1.5SMC43	38.7	43	47.3	1.0	34.8	5.0	24.0	61.9	0.101	4V3
1.5SMC43A	40.9	43	45.2	1.0	36.8	5.0	25.3	59.3	0.101	4A3
1.5SMC47	42.3	47	51.7	1.0	38.1	5.0	22.2	67.8	0.101	4V7
1.5SMC47A	44.7	47	49.4	1.0	40.2	5.0	23.2	64.8	0.101	4A7
1.5SMC51	45.9	51	56.1	1.0	41.3	5.0	20.4	73.5	0.102	5V1
1.5SMC51A	48.5	51	53.6	1.0	43.6	5.0	21.4	70.1	0.102	5A1
1.5SMC56	50.4	56	61.6	1.0	45.4	5.0	18.6	80.5	0.103	5V6
1.5SMC56A	53.2	56	68.8	1.0	47.8	5.0	19.5	77.0	0.103	5A6
1.5SMC62	55.8	62	68.2	1.0	50.2	5.0	16.9	89.0	0.104	6V2
1.5SMC62A	58.9	62	65.1	1.0	53.0	5.0	17.7	85.0	0.104	6A2
1.5SMC68	61.2	68	74.8	1.0	55.1	5.0	15.3	98.0	0.104	6V8
1.5SMC68A	64.6	68	71.4	1.0	58.1	5.0	16.3	92.0	0.104	6A8
1.5SMC75	67.5	75	82.5	1.0	60.7	5.0	13.9	108.0	0.105	7V5
1.5SMC75A	71.3	75	78.8	1.0	64.1	5.0	14.6	103.0	0.105	7A5
1.5SMC82	73.8	82	90.2	1.0	66.4	5.0	12.7	118.0	0.105	8V2
1.5SMC82A	77.9	82	86.1	1.0	70.1	5.0	13.3	113.0	0.105	8A2
1.5SMC91	81.9	91	100.0	1.0	73.7	5.0	11.4	131.0	0.106	9V1
1.5SMC91A	86.5	91	95.5	1.0	77.8	5.0	12.0	125.0	0.106	9A1

ELECTRICAL CHARACTERISTICS ($T_A = 25^\circ\text{C}$ unless otherwise noted) $V_F = 3.5\text{ V max}$, $I_F^{**} = 100\text{ A}$ for all types.

T-11-23

Device	Breakdown Voltage				Working Peak Reverse Voltage V_{RWM} Volts	Maximum Reverse Leakage @ V_{RWM} I_R μA	Maximum Reverse Surge Current I_{RSM}^\dagger Amps	Maximum Reverse Voltage @ I_{RSM} (Clamping Voltage) V_{RSM} Volts	Maximum Temperature Coefficient of V_{BR} $\%/\text{C}$	Device Marking
	V_{BR} @ I_T Volts									
	Min	Nom	Max	mA						
1.5SMC100	90.0	100	110.0	1.0	81.0	5.0	10.4	144.0	0.106	10V
1.5SMC100A	95.0	100	105.0	1.0	85.5	5.0	11.0	137.0	0.106	10A
1.5SMC110	99.0	110	121.0	1.0	89.2	5.0	9.5	158.0	0.107	11V
1.5SMC110A	105.0	110	116.0	1.0	94.0	5.0	9.9	152.0	0.107	11A
1.5SMC120	108.0	120	132.0	1.0	97.2	5.0	8.7	173.0	0.107	12V
1.5SMC120A	114.0	120	126.0	1.0	102.0	5.0	9.1	165.0	0.107	12A
1.5SMC130	117.0	130	143.0	1.0	105.0	5.0	8.0	187.0	0.107	13V
1.5SMC130A	124.0	130	137.0	1.0	111.0	5.0	8.4	179.0	0.107	13A
1.5SMC150	135.0	150	165.0	1.0	121.0	5.0	7.0	215.0	0.108	15V
1.5SMC150A	143.0	150	158.0	1.0	128.0	5.0	7.2	207.0	0.108	15A
1.5SMC160	144.0	160	176.0	1.0	130.0	5.0	6.5	230.0	0.108	16V
1.5SMC160A	152.0	160	168.0	1.0	136.0	5.0	6.8	219.0	0.108	16A
1.5SMC170	153.0	170	187.0	1.0	138.0	5.0	6.2	244.0	0.108	17V
1.5SMC170A	162.0	170	179.0	1.0	145.0	5.0	6.4	234.0	0.108	17A
1.5SMC180	162.0	180	198.0	1.0	146.0	5.0	5.8	258.0	0.108	18V
1.5SMC180A	171.0	180	189.0	1.0	154.0	5.0	6.1	246.0	0.108	18A
1.5SMC200	180.0	200	220.0	1.0	162.0	5.0	5.2	287.0	0.108	20V
1.5SMC200A	190.0	200	210.0	1.0	171.0	5.0	5.5	274.0	0.108	20A

† Surge Current Waveform per Figure 2.

$**1/2$ Square or Equivalent Sine Wave, PW = 8.3 ms, Duty Cycle = 4 Pulses per minute maximum.

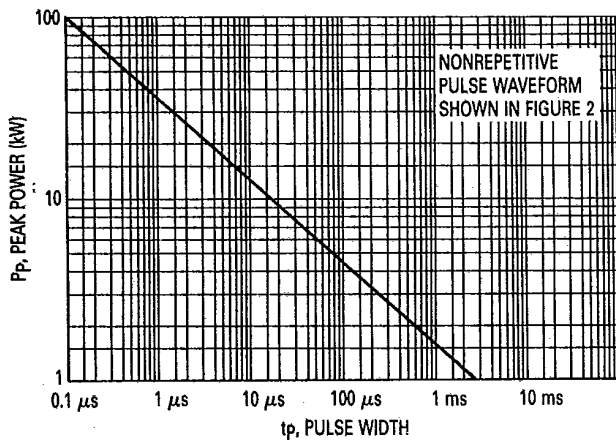

Figure 1. Pulse Rating Curve

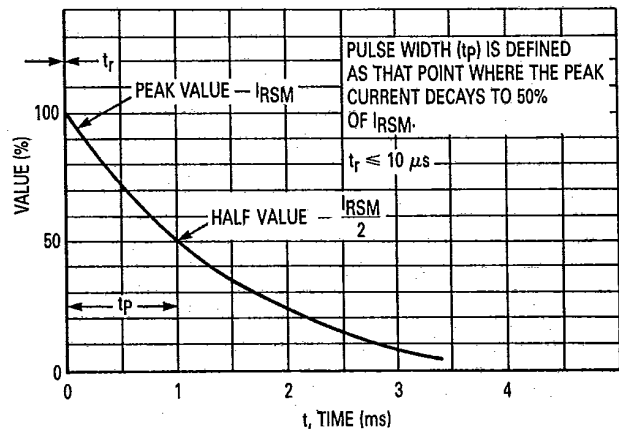

Figure 2. Pulse Waveform

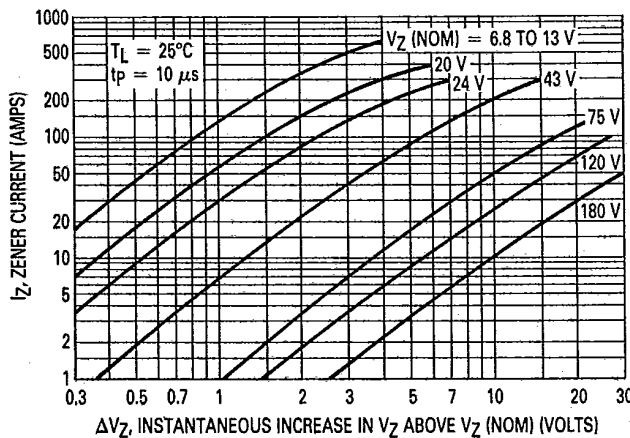

Figure 3. Dynamic Impedance

RESPONSE TIME

In most applications, the transient suppressor device is placed in parallel with the equipment or component to be protected. In this situation, there is a time delay associated with the capacitance of the device and an overshoot condition associated with the inductance of the device and the inductance of the connection method. The capacitive effect is of minor importance in the parallel protection scheme because it only produces a time delay in the transition from the operating voltage to the clamp voltage as shown in Figure 3.

The inductive effects in the device are due to actual turn-on time (time required for the device to go from zero current to full current) and lead inductance. This inductive effect produces an overshoot in the voltage across the equipment or component being protected as shown in

Figure 4. Minimizing this overshoot is very important in the application, since the main purpose for adding a transient suppressor is to clamp voltage spikes. The 1.5SMC6.8 series has very good response time, typically < 1.0 ns and negligible inductance. However, external inductive effects could produce unacceptable overshoot. Proper circuit layout, minimum lead lengths and placing the suppressor device as close as possible to the equipment or components to be protected will minimize this overshoot.

Some input impedance represented by Z_{in} is essential to prevent overstress of the protection device. This impedance should be as high as possible, without restricting the circuit operation.

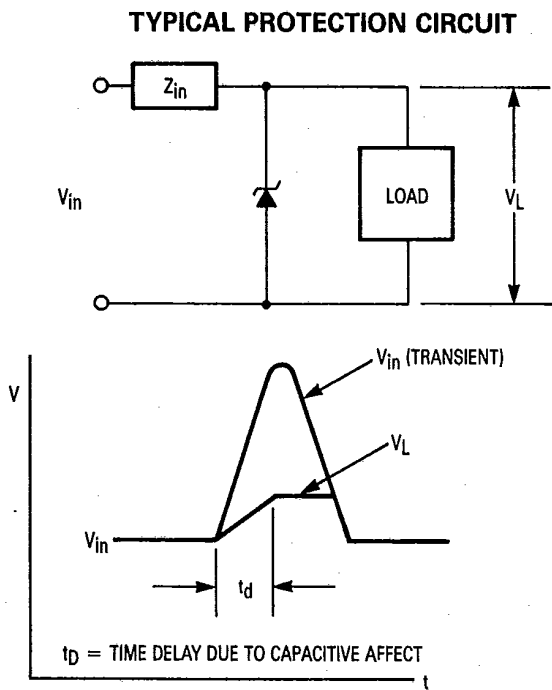

Figure 3.

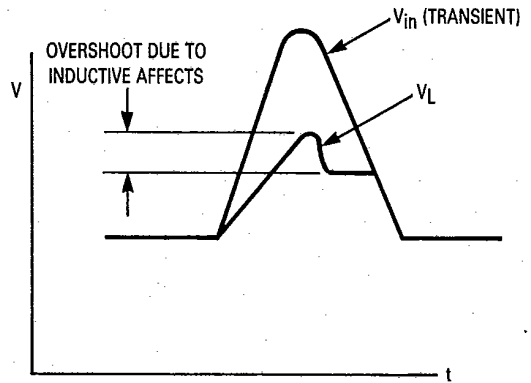

Figure 4.

Motorola reserves the right to make changes without further notice to any products herein to improve reliability, function or design. Motorola does not assume any liability arising out of the application or use of any product or circuit described herein; neither does it convey any license under its patent rights nor the rights of others. Motorola products are not authorized for use as components in life support devices or systems intended for surgical implant into the body or intended to support or sustain life. Buyer agrees to notify Motorola of any such intended end use whereupon Motorola shall determine availability and suitability of its product or products for the use intended. Motorola and are registered trademarks of Motorola, Inc. Motorola, Inc. is an Equal Employment Opportunity/Affirmative Action Employer.

Literature Distribution Centers:

- USA: Motorola Literature Distribution; P.O. Box 20912; Phoenix, Arizona 85036.
- EUROPE: Motorola Ltd.; European Literature Center; 88 Tanners Drive, Blakelands, Milton Keynes, MK14 5BP, England.
- ASIA PACIFIC: Motorola Semiconductors H.K. Ltd.; P.O. Box 80300; Cheung Sha Wan Post Office; Kowloon Hong Kong.
- JAPAN: Nippon Motorola Ltd.; 3-20-1 Minamiazabu, Minato-ku, Tokyo 106 Japan.



MOTOROLA