



Sav-Con[®] connector savers

Series 22 Geo-Marine connectors

940-025 Scoop-Proof High-Pressure Connector



How To Order							
Sample Part Number	940	-025	M	16	-26	S	N
Series No.	940						
Basic No.	-025						
Finish Symbol	B, J, M, N, NF, T, Z1 See Table I						
Shell Size	10, 12, 14, 16, 18, 20, 22, 24 See Table II						
Insert Arrangement	See Table II						
Contact Style	P = Pins, Panel Side S = Sockets Panel Side						
Alternate Key Position	1, 2, 3, 4, N = Normal; See Table III						

NOTES:

1. Assembly identified with manufacturer's name and P/N, space permitting.
2. Glenair 940-025 connector saver is designed to mate with Glenair 220-16 series Geo-Marine[®] connectors. (Scoop-Proof)

MATERIAL/FINISH:

- Barrel, shell, coupling nuts - see Table II.
- Contacts - copper alloy/gold plate.
- Insulators - high grade rigid dielectric/n.a.
- O-ring & seals - silicone/n.a.

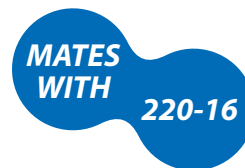
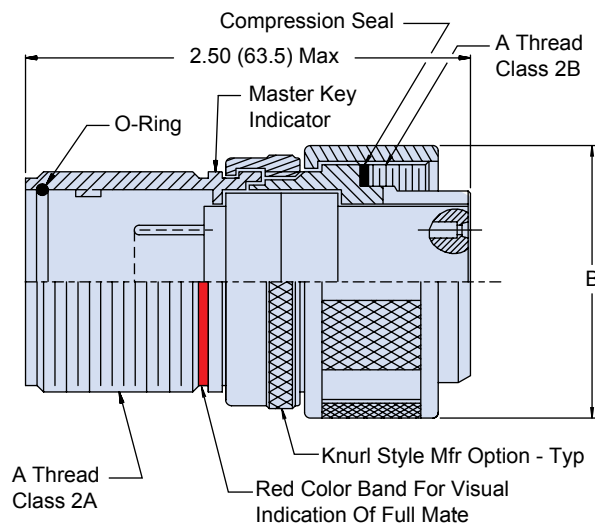

B



Sav-Con® connector savers

Geo-Marine™ Series 22

Reference Information



Sym	Finish Description
B	Aluminum/Cadmium Plate/Olive Drab
J	Aluminum/Gold Iridite Over Cadmium Plate Over Nickel
M	Aluminum/Electroless Nickel
N	Aluminum/Cadmium Plate/Olive Drab Over Nickel
NF	Aluminum/Cad/O. D. Over Electroless Nickel (500 Hour Salt Spray)
T	Aluminum/Cadmium Plate/Bright Dip Over Nickel
Z1	Stainless Steel/Passivate Coupling Nut Nickel - Aluminum - Bronze/Degrease

Shell Size	Series 22 Pattern	Service Rating	Contact Size/Quantity			
			22	20	16	12
10	10-2	II			2	
	10-4	I			4	
	10-6	I		6		
	10-13	M	13			
12	12-8	II			8	
	12-10	I		10		
	12-22	M	22			
14	14-4	II				4
	14-12	II			12	
	14-19	I		19		
	14-37	M	37			
16	16-6	II				6
	16-19	II			19	
	16-26	I		26		
	16-55	M	55			
18	18-8	I				8
	18-11	II			11	
	18-22	II			22	
	18-32	I		32		
20	18-66	M	66			
	20-11	II				11
	20-30	II			30	
	20-38	I	30		8	
22	20-41	I		41		
	20-79	M	79			
	22-19	II				19
	22-38	II			38	
24	22-50	M	48			
	22-55	I		55		
	22-85	M	85			
	24-24	I			16	16
	24-48	II			48	
24	24-61	I		61		
	24-100	M	100			
	24-128	M	128			

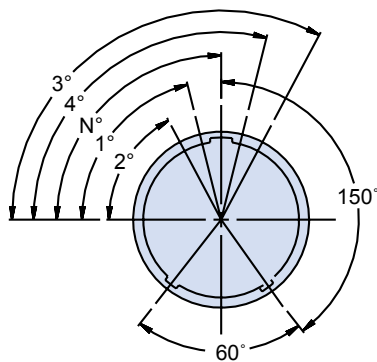

**FACE VIEW
RECEPTACLE**

SHELL SIZE DESIG.	N°	1°	2°	3°	4°
10	90	76	62	118	104
12	90	70	58	122	110
14	90	69	56	124	111
16	90	72	60	120	108
18	90	72	62	120	108
20	90	72	60	120	108
22	90	75	64	116	105
24	90	75	64	115	105

B