

RECOMMENDED P.C.B. LAYOUT

SWITCH FUNCTION		
POS. 1	POS. 2	POS. 3
ON	OFF	(ON)
2-3	OPEN	2-1

(ON)=MOMENTARY

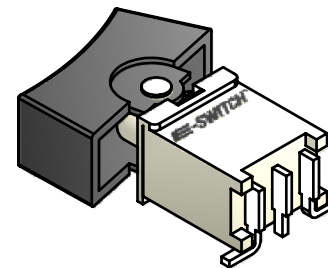
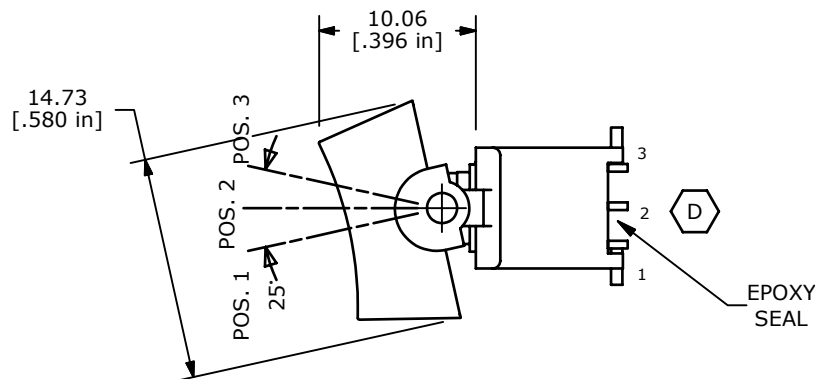
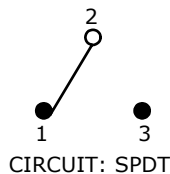

NOTES:

1. ALL DIMENSIONS IN MM[INCH].
2. GENERAL TOLERANCE: X.X=±0.4
X.XX=±0.25
3. TERM. NOS. FOR REFERENCE ONLY.
4. ELECTRICAL LIFE: 50,000 MAKE-AND-BREAK CYCLES AT FULL LOAD.
- ▲ 5. CONTACT MATERIAL: SILVER
6. CONTACT RATING: 1 AMP @250 VAC
3 AMPS @120 VAC OR 28 VDC
7. CONTACT RESISTANCE: 20MILLI-OHMS MAX. INITIAL @2-4 VDC
8. OPERATING TEMPERATURE:-30°C TO 85°C.
- ▲ 9. TERMINALS TO BE COPLANAR TO WITHIN 0.1[.004]
10. ▲ DENOTES CRITICAL PARAMETER
11. 2002/95/EC (ROHS) COMPATIBLE
- ▲ 12. PACKAGING: TAPE AND REEL, 450 PCS. PER REEL

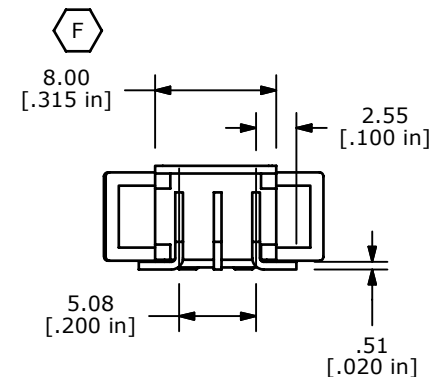
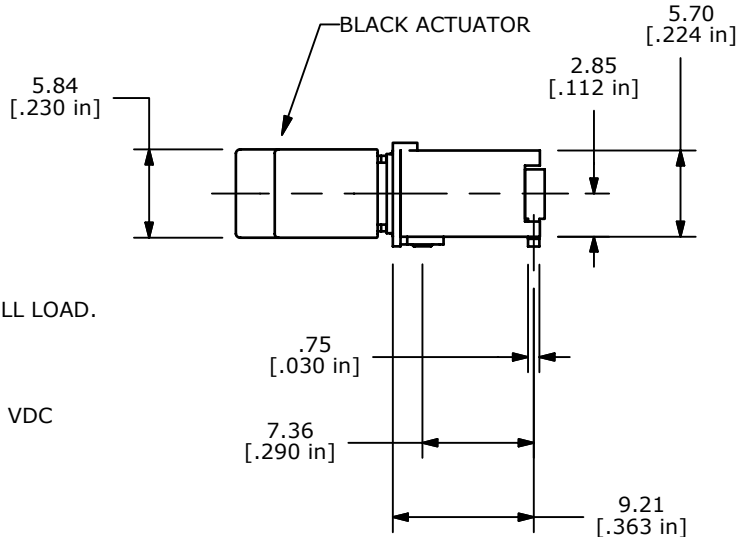

F	18061	CHANGED BODY WIDTH (FROM 8.25)	4/17/08	BLR
E	16079	ADD PACKAGING NOTE	6/2/06	BLR
D	14777	REVISE TERMINAL NUMBERS	3/18/05	BLR
C	13748	CHANGE ACTUATOR	2/4/04	BLR
REV	PCR NO	DESCRIPTION	DATE	BY

THE INFORMATION CONTAINED IN THIS DOCUMENT IS PROPRIETARY TO E-SWITCH AND IS NOT TO BE COPIED OR TRANSFERRED



TITLE 400BWMSP5R2BLKSM6QE

SCALE	DATE	DR	DWG	REV
2:1	4/17/2008	BLR	T460004	F