

R10.10^{+0.10}_{-.00}
[.398^{+0.004}_{-.000} in]

2.20^{+0.10}_{-.00}
[.087^{+0.004}_{-.000} in]

BLACK MARKING
WHITE ACTUATOR
BLACK BODY

11.00^{+0.10}_{-.00}
[.433^{+0.004}_{-.000} in]

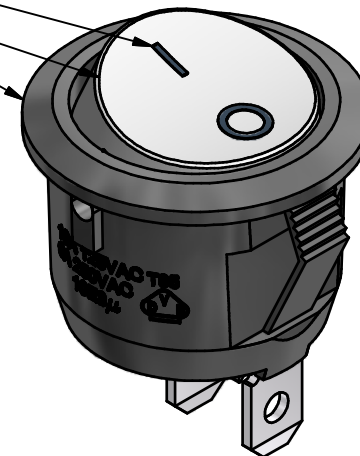

RECOMMENDED PANEL MOUNTING



CIRCUIT: SPST

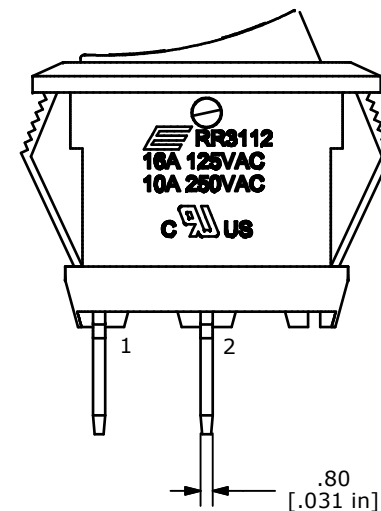
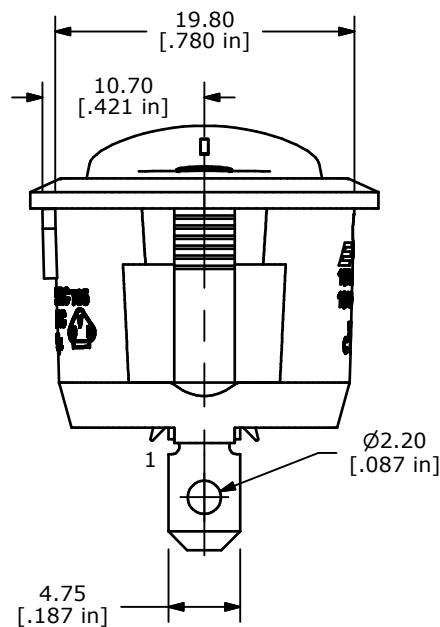
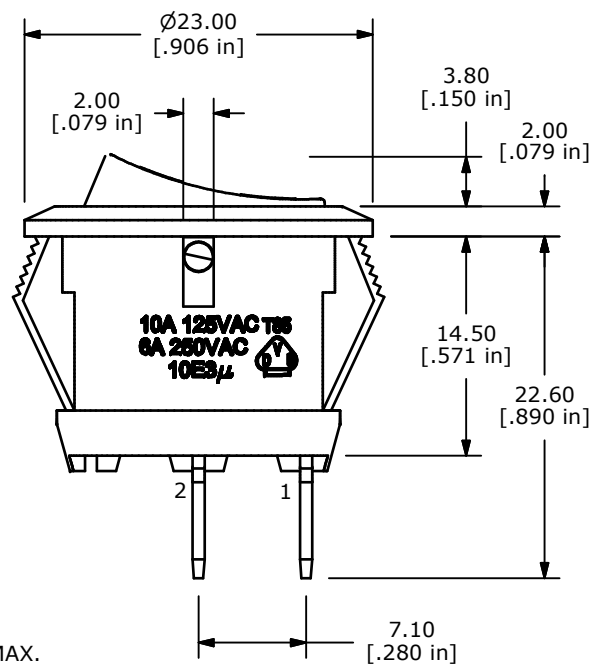

NOTES:

1. ALL DIMENSIONS IN MM [INCH]
2. GENERAL TOLERANCE: x.x=±0.4
x.xx=±0.25
3. TERM. NOS. FOR REF. ONLY
4. RATING: 10A 250VAC
16A 125VAC
5. CONTACT RESISTANCE: 50mOHM MAX.
6. INSULATION RESISTANCE: DC 500V 100MOHM MIN.
7. DIELECTRIC STRENGTH: AC 1500V 1 MIN
8. OPERATING TEMPERATURE: 0°C to 65°C
9. 2002/95/EC (ROHS) COMPLIANT



TITLE RR3112ABLKWHTNFF0

A	21503	INITIAL RELEASE	7/10/14	EBP
REV	PCR NO	DESCRIPTION	DATE	BY

THE INFORMATION CONTAINED IN THIS DOCUMENT IS PROPRIETARY TO E-SWITCH AND IS NOT TO BE COPIED OR TRANSFERRED

SCALE	DATE 7/10/2014	DR EBP	DWG F130432	REV A
-------	-------------------	-----------	----------------	----------