



12-Bit DAC with Input Registers

HS 3860
Data Converter Line

FEATURES

- $\pm 1/2$ LSB Linearity
- $\pm 0.3\%$ Absolute Accuracy Over Temperature
- 7 μ Sec Settling Time
- Input Registers
- MI L-STD-883 Screening Available (B Models)

DESCRIPTION

The HS 3860 is a 12-Bit digital-to-analog converter packaged in a hermetically sealed 24-pin double-width, dual-in-line package.

The D/A is constructed using hybrid microcircuit technology and includes a precision thin-film network, laser-trimmed to produce a high linearity, high accuracy converter, stable over a wide temperature range. Errors in linearity and accuracy are specified at room temperature as well as operating temperature extremes for both military and commercial products.

The HS 3860 includes an internal precision reference supply, a fast output amplifier for minimum settling time, and input registers for easier microprocessor interface.

MIL-STD-883 Rev. C, Level B screening and processing is available in the "B" grade device. Operating temperature range for the HS 3860B is -55°C to $+125^{\circ}\text{C}$.

FUNCTIONAL DIAGRAM

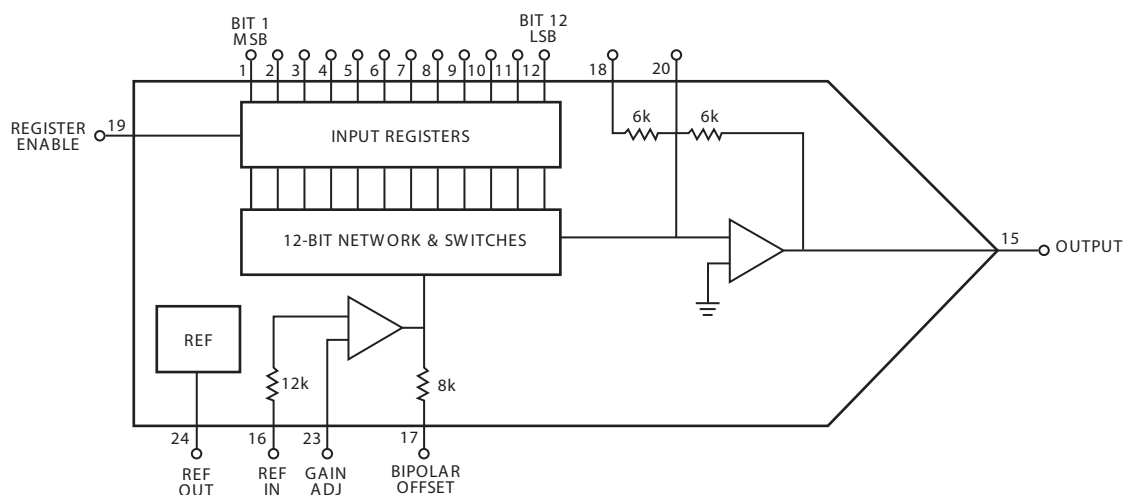

HS3860

SPECIFICATIONS

(Typical for all models @ +25°C and nominal power supplies unless otherwise noted)

MODEL	HS3860
TYPE	Digital to Analog Converter

DIGITAL INPUTS

Resolution	12 bits
Coding	Complementary Binary/ Offset Binary
Logic Levels (Data Inputs)	
Logic "1" (30µA max)	+2V min. +5.5V max
Logic "0" (-0.6mA max)	-0.5V min, +0.7V max
Register Enable Logic ¹	
Logic "1" (60µA max)	+2V min, +5.5V max
Logic "0" (-1.2mA max)	-0.5V min, +0.7V max
Pulse Width	60ns min
Set up Time	40ns min

ANALOG OUTPUT

Output Voltage Ranges	0 to +10; ±5; ±10
Output Impedance	0.05 typ
Output Current	±5mA
Short Circuit Duration	Indefinite to Common

ACCURACY

Linearity Error ^{2, 3}	
0°C to +70°C	±1/4 LSB typ; ±1/2 LSB max
-55°C to +125°C	±1/2 LSB max
Monotonicity	Guaranteed Over
Temperature	
Full Scale Absolute Error ^{4, 5}	
+25°C	±0.05% F.S.R. typ; ±0.1% F.S.R. max
-55°C to +125°C ⁶	±0.15% F.S.R. typ; ±0.3% F.S.R. max
Zero Error ^{4, 5}	
25°C	±0.025% F.S.R. typ; ±0.05% F.S.R. max
-55°C to 125°C ⁶	±0.05% F.S.R. typ; ±0.1% F.S.R. max
Gain Error	±0.1%
Gain Drift	±10 ppm/°C

CONVERSION SPEED

Settling Time	
20V Step	5µs typ; 7µs max
10V Step	3µs typ; 5µs max
Output Slew Rate	20 volts/µs typ

REFERENCE OUTPUT

Voltage	6.3 volts ±5%
Tempco	±10 ppm/°C
Load Current	100µA max

POWER SUPPLIES

Power Supply Range	
+15V Supply	+14V to +18V
-15V Supply	-14V to -18V
+5V Supply	+4V to +7V
Power Supply Rejection	
+15V (from +14.55 to +15.45V)	-0.01% F.S.R./% typ; ±0.04% F.S.R./% max
-15V (from -14.55 to -15.45V)	±0.001% F.S.R./% typ; ±0.004% F.S.R./% max
Current Drain	
+15V Supply	25mA max
-15V Supply	25mA max
+5V Supply	50mA max
Power Consumption	675mW typ, 1000mW max

MECHANICAL

Case Style 24 Pin DIP, Ceramic

NOTES

- The analog output follows the digital input when Register Enable is a logic "0". The analog output is constant when the Register Enable is a logic "1".
- SatCon guarantees and tests maximum Linearity Error at the extremes of the operating temperature and at room temperature. ±1/2 LSB Linearity Error guarantees monotonicity and differential linearity of ±1 LSB.
- One LSB is 0.024% F.S.R. for a 12 bit DAC.
- F.S.R. is Full Scale Range. For the ±10V output range the F.S.R. is 20 volts and 1 LSB is 4.88mV.
- Absolute Accuracy Error includes linearity, gain, offset and all other errors and is specified without the use of adjustments.
- Commercial Models are specified over a temperature range of 0°C to +70°C.

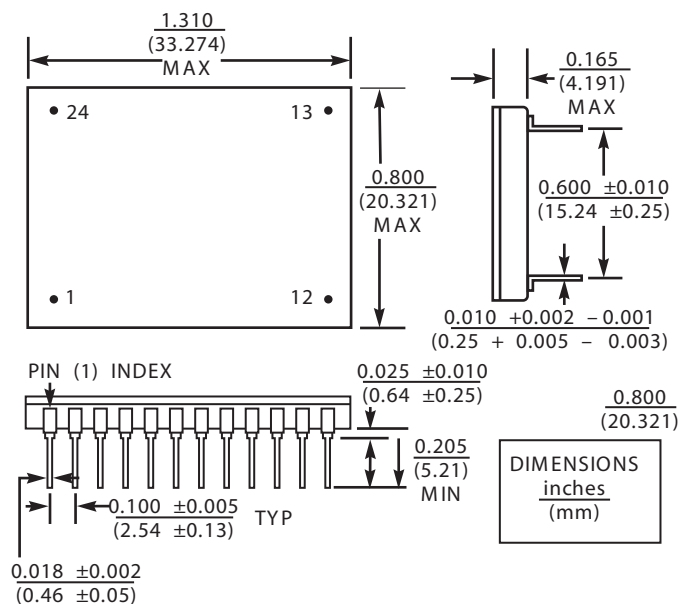

PIN DESIGNATIONS

PIN	FUNCTION	PIN	FUNCTION
1	Bit 1	24	REF OUT
2	Bit 2	23	-Full Scale Adjust (Gain Adj)
3	Bit 3	22	+15V
4	Bit 4	21	Common
5	Bit 5	20	Summing Junction
6	Bit 6	19	Register Enable
7	Bit 7	18	10V Range
8	Bit 8	17	Bipolar Offset
9	Bit 9	16	REF IN
10	Bit 10	15	Analog Output
11	Bit 11	14	-15V
12	Bit 12	13	+5V

Continued on next page.

HS3860

APPLICATION INFORMATION

FULL SCALE ADJUSTMENT

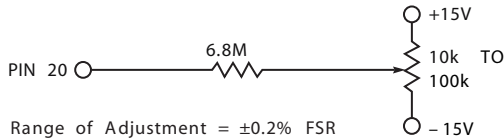

Connect the full scale potentiometer as shown and apply all "0's" to the digital inputs. Adjust the potentiometer until the analog output is equal to the maximum positive voltage for the chosen output range as shown in the table

ZERO (-FULL SCALE) ADJUSTMENT

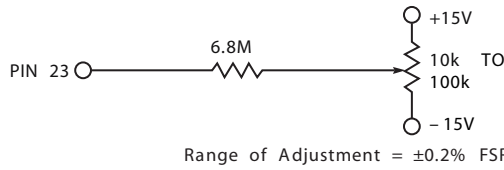

Connect the zero (-full scale) potentiometer as shown and apply all "1's" to the digital inputs. Adjust the potentiometer until the analog output is equal to zero volts for unipolar output ranges and -full scale voltage for bipolar output ranges.

INPUT LOGIC CODING AND OUTPUT RANGE SELECTION

DIGITAL INPUT		ANALOG OUTPUT		
MSB	LSB	0 to +10V	$\pm 5V$	$\pm 10V$
0000	0000 0000	+9.9976V	+4.9976V	+9.9951V
0000	0000 0001	+9.9951V	+4.9951V	+9.9902V
0111	1111 1111	+5.0000V	0.0000V	0.0000V
1000	0000 0000	-0.0024V	-0.0024V	-0.0049V
1111	1111 1110	+0.0024V	-4.9976V	-9.9951V
1111	1111 1111	0.0000V	-5.0000V	-10.0000V
CONNECT		24 to 16	24 to 16	24 to 16
PIN TO PIN		17 to 21 15 to 18	17 to 20 15 to 18	17 to 20

ORDERING INFORMATION

MODEL	DESCRIPTION
HS3860B	MIL, 12Bit D/A
HS 3860C	COMM, 12 Bit D/A

Specifications subject to change without notice.