

3DC11LPCAP

SMD CAP 3D Coil 13x12.8x3.7 mm (2.38 mH - 7.2 mH) Low Profile

Characteristics

- Evolution of the 3DC11LP series.
- The cap, made of high quality plastic material, improves the mechanical protection to the coil.
- Keyless Entry Systems is a typical application for this coil.
- Very good electrical performance.
- High stability in temperature (-40°C to +85°C).
- High sensitivity values.
- The inductance in each axis can be customized to achieve customer requirements.
- Designs at lower frequencies, 20 kHz or 40 kHz, show a very good electrical performance as well.

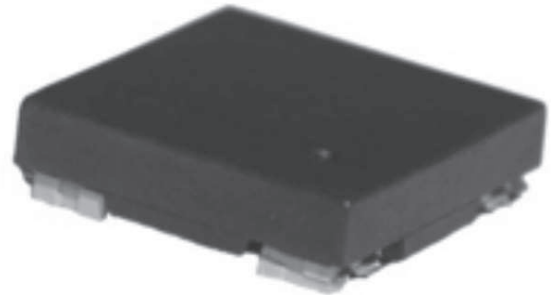

Dimensions and recommended pad layout

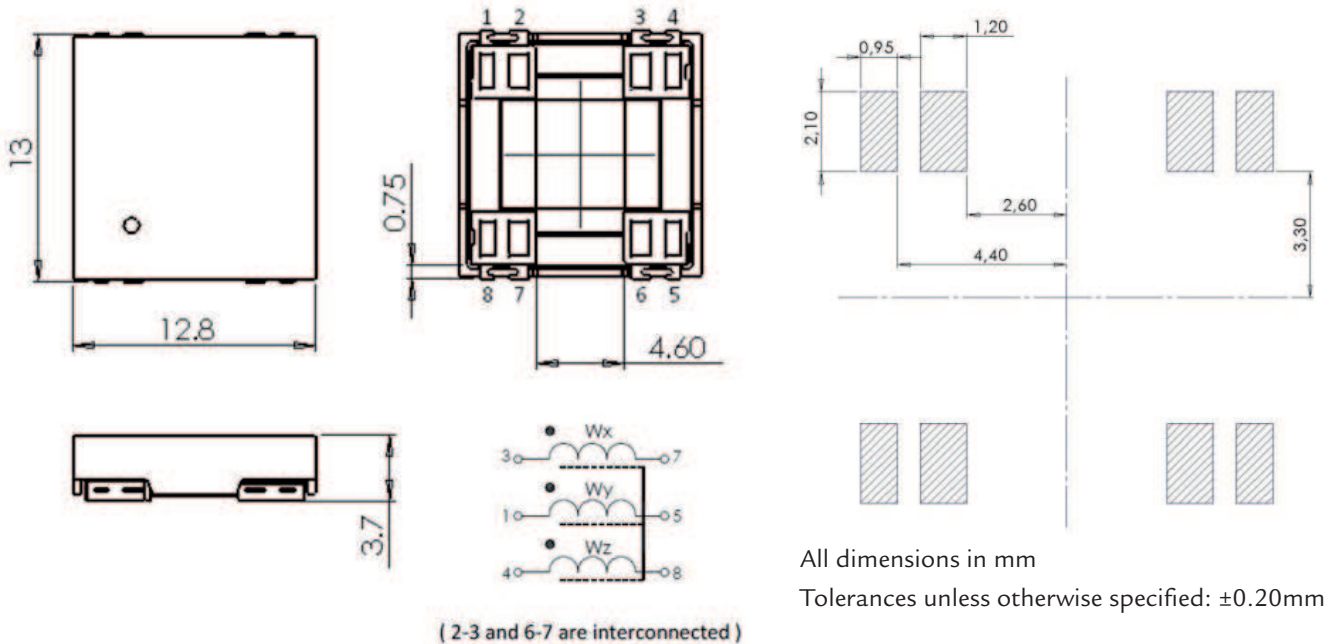

Electrical specifications

P/N	L x,y,z (mH)	Q x,y,z Min	Fre- quency (kHz)	Cres (pF)	SRF x,y (kHz) Min	SRF z (kHz) Min	DCR x,y (Ω) Max	DCR z (Ω) Max	Sensitivity x,y,z (mVpp/ App/m) Min	Length (mm)	Width (mm)	Height (mm)
3DC11CAP-0238J	2.38	25	125	680	500	900	50	50	40	13.0	12.8	3.7
3DC11CAP-0491J	4.91	32	125	330	350	600	74	98	65	13.0	12.8	3.7
3DC11CAP-0720J	7.20	25	125	225	330	500	84	120	72	13.0	12.8	3.7

This chart is a reference guide for the most common required values at working frequency of 125 kHz. Any other inductance value at LF or tighter tolerances can be provided. Also can be supplied different inductance values in the different winding axis. Please contact our sales department for any inquiry.

L and Q factor measured at 125 kHz, 1 Vac.

Sensitivity measured with Helmholtz coils $H=8.36$ App/m @125 kHz. Contact us for measurement specification.

SRF: Self Resonant Frequency of the coil.