

High Voltage NPN Transistor

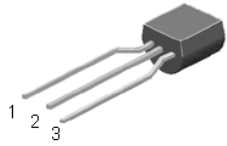

TO-92

Pin Definition

- 1. Emitter
- 2. Collector
- 3. Base



TO-251

Pin Definition

- 1. Base
- 2. Collector
- 3. Emitter

INTERNAL SCHEMATIC DIAGRAM

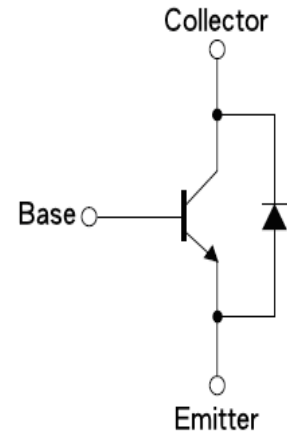

Features

- High Voltage
- Very High Switch Speed
- BV_{CEO} : 400V
- BV_{CBO} : 800V
- I_C : 1.5A
- Silicon Triple Diffused Type

Application

- Electronic Ballasts
- Adapter
- Lighting

ABSOLUTE MAXIMUM RATINGS ($T_c = 25^\circ\text{C}$)

Parameter	Symbol	Max Rating	Unit
Collector-Base Voltage	VCBO	800	V
Collect-Break Down Voltage	VCES	800	V
Collector-Emitter Voltage	VCEO	400	V
Emitter-Base Voltage	VEBO	9	V
Collector Current(DC)	IC	1.5	A
Collector Current(Pulse)	ICP	2	A
Total Power Dissipation(TO92)	PD	1.5	W
Total Power Dissipation(TO251)		30	
Junction Temperature	TJ	150	$^\circ\text{C}$
Operating Junction and Storage Temperature Range	TSTG	-55 ~ +150	$^\circ\text{C}$

ELECTRICAL CHARACTERISTICS (T_c = 25°C)

Parameter	Symbol	Test Condition	Min	Typ	Max	Unit
Collector-Base Voltage	BVCBO	IC = 1mA, IB=0	800	–	–	V
Collector-Emitter Breakdown Voltage	BVCEO	IC = 1mA, IE=0	400	–	–	V
Emitter- Base Breakdown Voltage	BVEBO	IE = 1mA, IC=0	9	–	–	V
Collector Cutoff Current	ICBO	VCB = 700V, IE=0	–	–	1	μA
Emitter Cutoff Current	IEBO	VEB = 9V, IC=0	–	–	1	μA
DC Current Gain	hFE1	VCE = 10V, IC=10mA	20	–	–	
	hFE2	VCE = 10V, IC=100mA	25	–	45	
	hFE3	VCE = 10V, IC=280mA	20	–	–	
Collector-Emitter Saturation Voltage	VCE(SAT1)	IC/IB = 50mA / 10mA	–	–	0.5	V
	VCE(SAT2)	IC/IB = 100mA / 10mA	–	–	1	
	VCE(SAT3)	IC/IB = 200mA / 20mA	–	–	3	
Base-Emitter Saturation Voltage	VBE(SAT1)	IC/IB = 50mA / 10mA	–	–	1.15	V
	VBE(SAT2)	IC/IB = 100mA / 10mA	–	–	1.25	

Dynamic

Frequency	f _r	VCE=10V, IC=0.1A	4	–	–	MHz
Output Capacitance	C _{ob}	VCB=10V, f=01.MHz	–	21	–	pF

Resistive Load Switching Time (Ratings)

Rise Time	t _r	V _{cc} =125V, IC=100mA, IB1 = IB2 = 20mA, t _p = 25uS	–	–	2	uS
Storage Time	t _{STG}		–	5	6	uS
Fall Time	t _f	Duty Cycle ≤ 1%	–	0.2	0.7	uS

Electrical Characteristic Curves

Static Characteristics

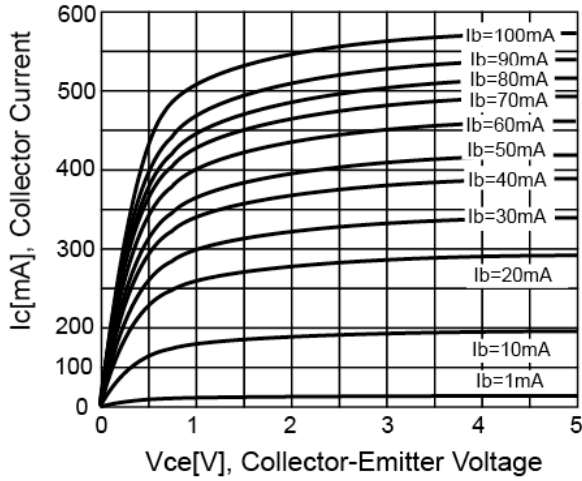

DC Current Gain

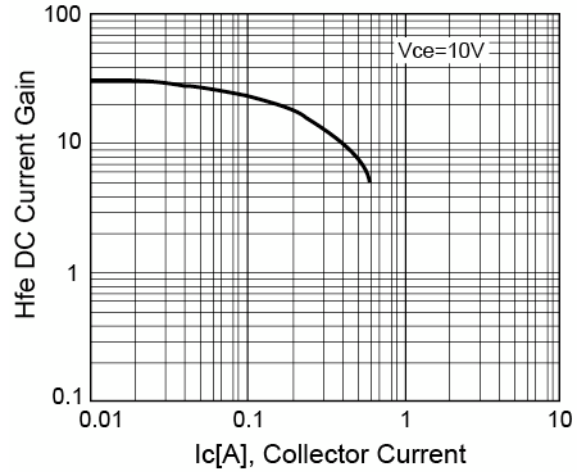

VCE(SAT) v.s. VBE(SAT)

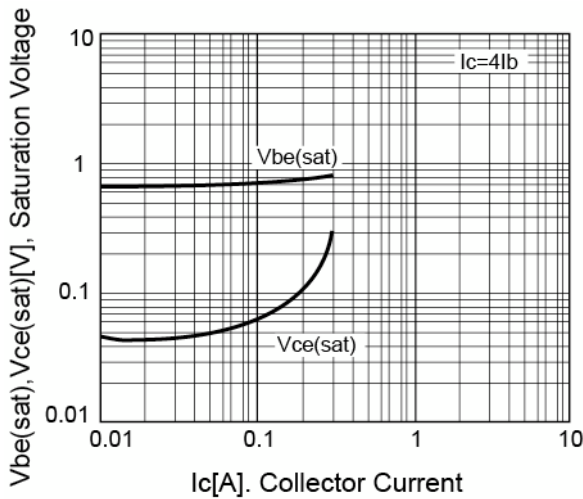

Power Derating

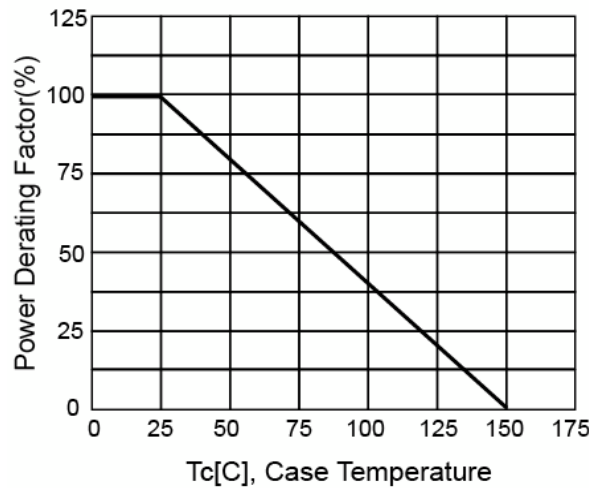

Reverse Bias SOA

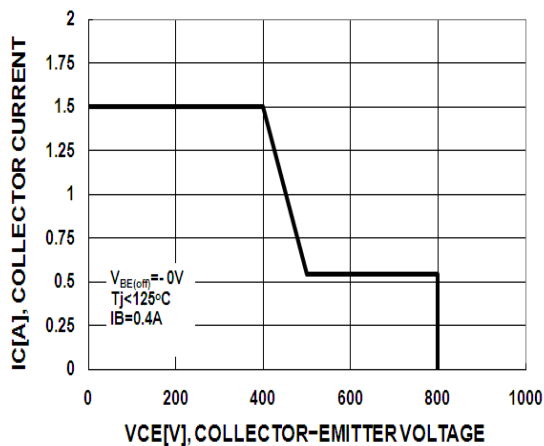

Safety Operating Area

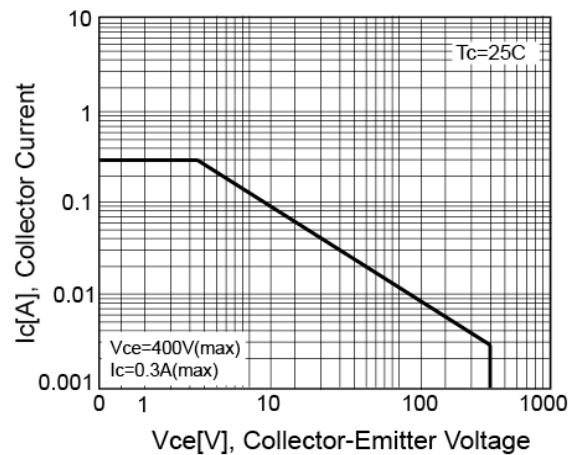

Ordering Information

Type NO	Marking	Package Code
WTBV116DL	116DL	TO-92

Marking and Pin Define

First Line	WTC	Company Name	
Second Line	116DL	Product Code	
Third Line	A J 0 T L	1st (Year Code)	A-2010 B-2011 C-2012 ...
		2nd (Month Code)	A-Jan, B-Feb, C-Mar, D-Apr, E-May, F-Jun, G-Jul, H-Aug, I-Sep, J-Oct, K-Nov, L-Dec
		3rd (Lot Code)	0~9 , A~Z
		4th (Product Code)	M - MOS , T - Transistor, L - Linear
		5th (Package Code)	I - TO251, D - TO252 , L - TO92, M - TO126, X - TO220, F - TO220F, Y - SOT89, S - SOP8
		6th (Spec Code)	(Reserve)

TO-92 Package Dimension

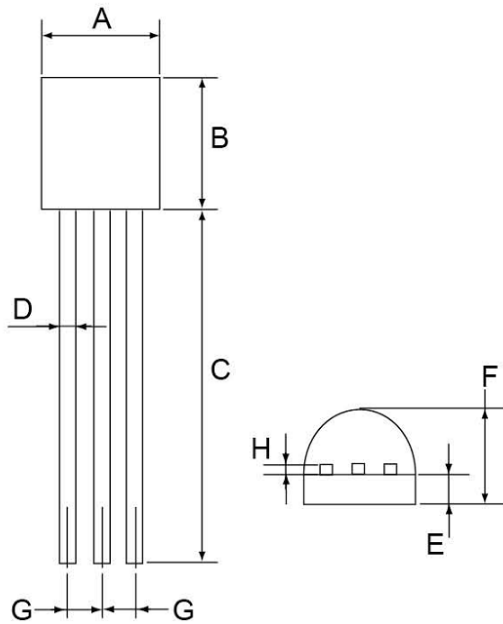

TO-92 DIMENSION				
DIM	MILLIMETERS		INCHES	
	MIN	MAX	MIN	MAX
A	4.3	4.7	0.169	0.185
B	4.3	4.7	0.169	0.185
C	13.53(typ)		0.532(typ)	
D	0.39	0.49	0.015	0.019
E	1.18	1.28	0.046	0.5
F	3.3	3.7	0.13	0.146
G	1.27	1.31	0.05	0.051
H	0.33	0.43	0.013	0.017

Ordering Information

Type NO	Marking	Package Code
WTBV116DI	116DI	TO-251

Marking and Pin Define

First Line	WTC	Company Name	
Second Line	116DI	Product Code	
Third Line	A J 0 T M	1st (Year Code)	A-2010 B-2011 C-2012 ...
		2nd (Month Code)	A-Jan, B-Feb, C-Mar, D-Apr, E-May, F-Jun, G-Jul, H-Aug, I-Sep, J-Oct, K-Nov, L-Dec
		3rd (Lot Code)	0~9 , A~Z
		4th (Product Code)	M - MOS , T - Transistor, L - Linear
		5th (Package Code)	I - TO251, D - TO252 , L - TO92, M - TO126, X - TO220, F - TO220F, Y - SOT89, S - SOP8
		6th (Spec Code)	(Reserve)

TO-251 Package Dimension

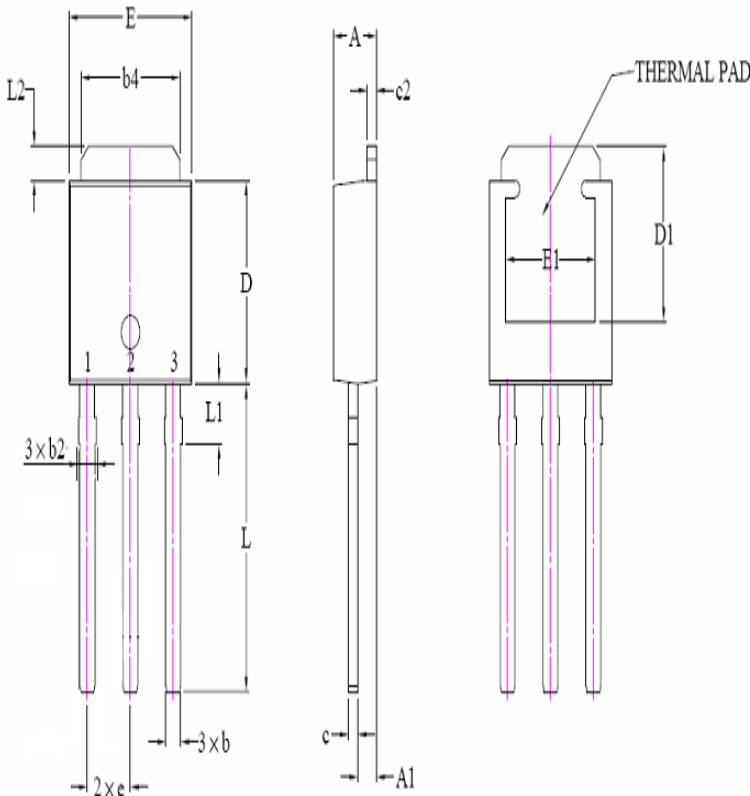

Symbol	TO-251DL			
	Millimeters		Inches	
	Min	Max	Min	Max
A	2.220	2.420	0.087	0.095
A1	0.890	1.140	0.035	0.045
b	0.550	0.670	0.022	0.026
b2	0.780	0.980	0.030	0.038
b4	5.200	5.400	0.205	0.213
c	0.460	0.570	0.018	0.023
c2	0.450	0.550	0.018	0.022
D	5.950	6.250	0.234	0.246
D1	4.200	4.500	0.165	0.177
E	6.400	6.700	0.252	0.264
E1	4.750	4.850	0.187	0.191
e	2.28 REF		0.090 REF	
L	8.900	9.500	0.350	0.374
L1	1.900	2.290	0.075	0.090
L2	0.900	1.000	0.035	0.039