

AN6093NSA

Digital Communication Orthogonal Modulator IC

Overview

The AN6093NSA is a orthogonal modulator IC for PHS. It incorporates a phase shifter and an APC circuit for indirect modulation in the 1.9 GHz band. It efficiently prevents power from leaking to adjacent channels. When provided with an LC filter, it can efficiently suppress IF-band local harmonic spurious.

Features

- Operating supply voltage range: 2.7 to 4 V
- 1.9 GHz indirect modulation
- LO1's eighth-order harmonic suppression : -58dBc or better
- High-power output : -12 dBm
- Variable range: APC = typ 38 dB (f_{out} = 1.9 GHz)
- Phase shifter frequency : 233 MHz
- Package: SSOP016-P-0225A with 0.65 mm pitch

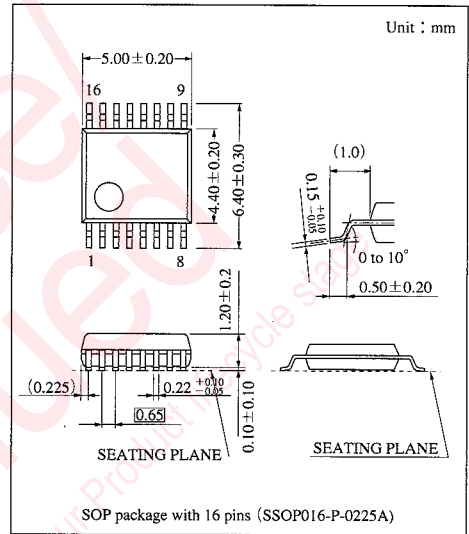

Block Diagram

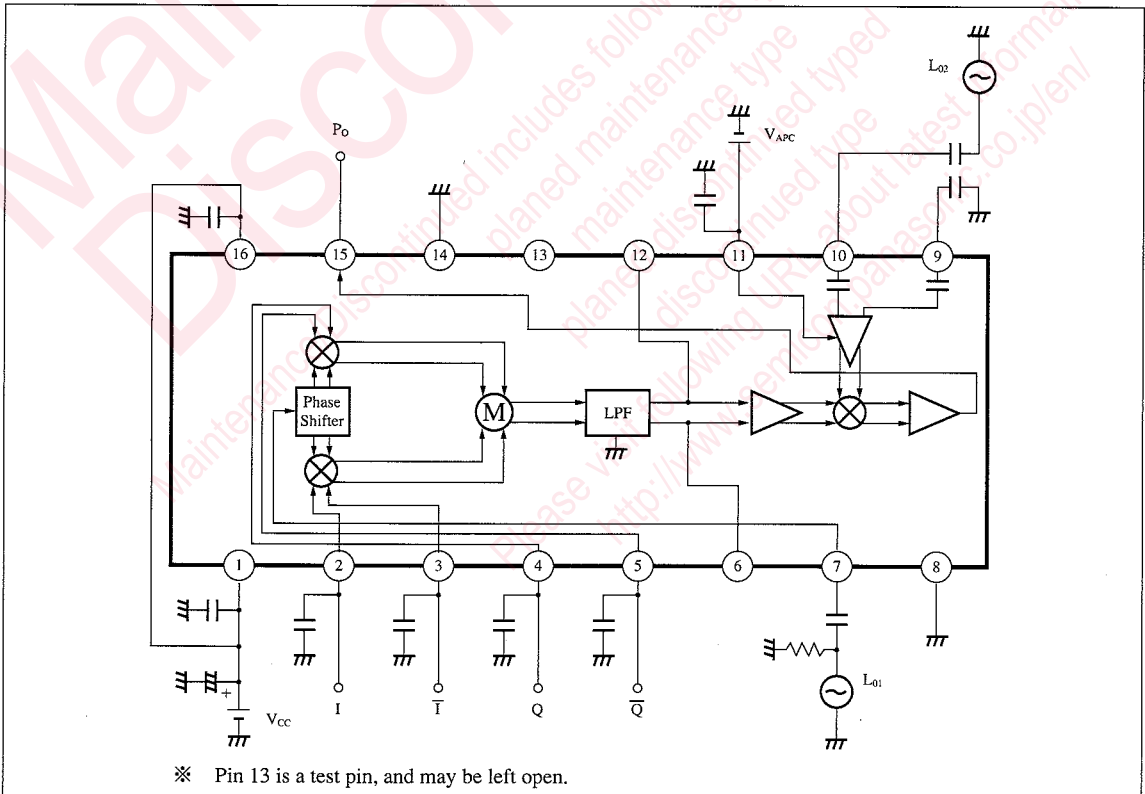

Mobile
Communi-
cation

Pin Descriptions

Pin No.	Description	Pin No.	Description
1	V _{CC} (mod)	9	LO2R
2	Iinput	10	LO2
3	Iinput	11	APC/BS
4	Qinput	12	LC2
5	Qinput	13	Test Pin
6	LC1	14	GND
7	LO1	15	RFoutput
8	GND	16	V _{CC} (UP-MIX)

Absolute Maximum Ratings (T_a = 25°C)

Parameter	Symbol	Rating	Unit
Supply voltage	V _{CC}	4.2	V
Supply current	I _{CC}	60	mA
Power dissipation	P _D	252	mW
Operating ambient temperature	T _{opr}	-20 to +60	°C
Storage temperature	T _{stg}	-55 to +125	°C

Note) Protect from electrostatic discharge.

Recommended Operating Range

Parameter	Symbol	Range
Operating supply voltage range	V _{CC}	2.7 to 4V

Electrical characteristics (T_a = 25 ± 2°C)

Parameter	Symbol	Condition	min	typ	max	Unit
Output level (1)	P _{O1}	Lo1 = 233MHz, -10dBm Lo2 = 1660MHz, -15dBm V _{APC} = 2.5V	-15	-12	—	dBm
Output level (2)	P _{O2}	Lo1 = 233MHz, -10dBm Lo2 = 1685MHz, -15dBm V _{APC} = 2.5V	-15	-12	—	dBm
Current consumption	I _{CC}	Lo1 = 233MHz, -10dBm Lo2 = 1672.5MHz, -15dBm V _{APC} = 2.5V	—	29	38	mA

Notes) V_{CC} = 3V

IQ signal : 0.5V_{P-P} (two-phase), π/4 QPSK modulation input DC bias = 1.8 V

P_{O1} output frequency = 1893.024 MHz

P_{O2} output frequency = 1918.024 MHz

■ Electrical Characteristics (design values for reference) ($T_a = 25 \pm 2^\circ\text{C}$)

The following design values are for reference only (not guaranteed).

Parameter	Symbol	Condition	min	typ	max	Unit
Minimum output level*1	Pmin	Lo1=233MHz, -10dBm Lo2=1672.5MHz, -15dBm VAPC=1.0V	—	-50	-45	dBm
1st local leak suppression*1	CL1	Lo1=233MHz, -10dBm Lo2=1672.5MHz, -15dBm VAPC=2.5V	—	-25	—	dBc
2nd local leak suppression*1	CL2	Lo1=233MHz, -10dBm Lo2=1672.5MHz, -15dBm VAPC=2.5V	—	-15	—	dBc
Image leak suppression*1	IL	Lo1=233MHz, -10dBm Lo2=1672.5MHz, -15dBm VAPC=2.5V IQ : Level adj.	—	-35	-30	dBc
Adjacent spurious suppression*2	DU1	Lo1=233MHz, -10dBm Lo2=1672.5MHz, -15dBm VAPC=2.5V	—	-55	-50	dBc
In-band output deviation*3	ΔP	Lo1=233MHz, -10dBm Lo2=1660 to 1685MHz, -15dBm VAPC=2.5V	—	± 1.6	—	dB
3rd intermodulation distortion suppression*3 (Pout = -1.5dBm)	IM3	Lo1=233MHz, -10dBm Lo2=1672.5MHz, -15dBm VAPC=2.5V	—	-25	—	dBc
fLO1 + fLO2, Local leak suppression*1	CL	Lo1=233MHz, -10dBm Lo2=1672.5MHz, -15dBm VAPC=2.5V IQ : DC offset adj.	—	-35	-30	dBc
Adjacent channel power leak suppression (600 kHz separation)	BL	Lo1=233MHz, -10dBm Lo2=1672.5MHz, -15dBm VAPC=2.5V	—	-65	-60	dBc
Base-band distortion suppression*1	BH	Lo1=233MHz, -10dBm Lo2=1672.5MHz, -15dBm VAPC=2.5V	—	-40	-30	dBc
Adjacent spurious suppression ^{Note.2)}	DU2	Using an LC filter between pins 6 and 12, removing 8fLo1, and 2fLo2 to 6fLo1 components	—	-60	—	dBc

Note 1) $V_{CC} = 3V$

IQ signal : $0.5V_{P-P}$, two-phase, input DC bias = 1.8V

*1 : $\pi/4$ QPSK modulation

*2 : $\pi/4$ QPSK modulation

*3 : PN9-stage modulation

Note 2) The output level decreases if an LC filter is attached.

■ Usage note

Surge breakdown levels

The following are design values for reference only (not guaranteed).

Condition : $C = 200 \text{ pF}$, and $R = 0 \ \Omega$

Pin No.	Positive breakdown level (V)
2	130
3	130
4	130
5	130

Note) Breakdown level is 200 V or more for those pins other than above and for negative surges.



Request for your special attention and precautions in using the technical information and semiconductors described in this book

- (1) If any of the products or technical information described in this book is to be exported or provided to non-residents, the laws and regulations of the exporting country, especially, those with regard to security export control, must be observed.
- (2) The technical information described in this book is intended only to show the main characteristics and application circuit examples of the products. No license is granted in and to any intellectual property right or other right owned by Panasonic Corporation or any other company. Therefore, no responsibility is assumed by our company as to the infringement upon any such right owned by any other company which may arise as a result of the use of technical information described in this book.
- (3) The products described in this book are intended to be used for standard applications or general electronic equipment (such as office equipment, communications equipment, measuring instruments and household appliances).
Consult our sales staff in advance for information on the following applications:
 - Special applications (such as for airplanes, aerospace, automobiles, traffic control equipment, combustion equipment, life support systems and safety devices) in which exceptional quality and reliability are required, or if the failure or malfunction of the products may directly jeopardize life or harm the human body.
 - Any applications other than the standard applications intended.
- (4) The products and product specifications described in this book are subject to change without notice for modification and/or improvement. At the final stage of your design, purchasing, or use of the products, therefore, ask for the most up-to-date Product Standards in advance to make sure that the latest specifications satisfy your requirements.
- (5) When designing your equipment, comply with the range of absolute maximum rating and the guaranteed operating conditions (operating power supply voltage and operating environment etc.). Especially, please be careful not to exceed the range of absolute maximum rating on the transient state, such as power-on, power-off and mode-switching. Otherwise, we will not be liable for any defect which may arise later in your equipment.
 - Even when the products are used within the guaranteed values, take into the consideration of incidence of break down and failure mode, possible to occur to semiconductor products. Measures on the systems such as redundant design, arresting the spread of fire or preventing glitch are recommended in order to prevent physical injury, fire, social damages, for example, by using the products.
- (6) Comply with the instructions for use in order to prevent breakdown and characteristics change due to external factors (ESD, EOS, thermal stress and mechanical stress) at the time of handling, mounting or at customer's process. When using products for which damp-proof packing is required, satisfy the conditions, such as shelf life and the elapsed time since first opening the packages.
- (7) This book may be not reprinted or reproduced whether wholly or partially, without the prior written permission of our company.