



12-Channel/8-Channel, Flash-Configurable System Monitors with Nonvolatile Fault Registers

General Description

The MAX16070/MAX16071 flash-configurable system monitors supervise multiple system voltages. The MAX16070/MAX16071 can also accurately monitor ($\pm 2.5\%$) one current channel using a dedicated high-side current-sense amplifier. The MAX16070 monitors up to twelve system voltages simultaneously, and the MAX16071 monitors up to eight supply voltages. These devices integrate a selectable differential or single-ended analog-to-digital converter (ADC). Device configuration information, including overvoltage and undervoltage limits and timing settings are stored in nonvolatile flash memory. During a fault condition, fault flags and channel voltages can be automatically stored in the nonvolatile flash memory for later read-back.

The internal 1% accurate 10-bit ADC measures each input and compares the result to one overvoltage, one undervoltage, and one early warning limit that can be configured as either undervoltage or overvoltage. A fault signal asserts when a monitored voltage falls outside the set limits. Up to three independent fault output signals are configurable to assert under various fault conditions.

Because the MAX16070/MAX16071 support a power-supply voltage of up to 14V, they can be powered directly from the 12V intermediate bus in many systems.

The MAX16070/MAX16071 include eight/six programmable general-purpose inputs/outputs (GPIOs). GPIOs are flash configurable as dedicated fault outputs, as a watchdog input or output, or as a manual reset.

The MAX16070/MAX16071 feature nonvolatile fault memory for recording information during system shutdown events. The fault logger records a failure in the internal flash and sets a lock bit protecting the stored fault data from accidental erasure. An SMBus™ or a JTAG serial interface configures the MAX16070/MAX16071. The MAX16070/MAX16071 are available in a 40-pin, 6mm x 6mm, TQFN package. Both devices are fully specified from -40°C to $+85^{\circ}\text{C}$.

Applications

Networking Equipment
Telecom Equipment (Base Stations, Access)
Storage/Raid Systems
Servers

SMBus is a trademark of Intel Corp.

Features

- ◆ Operate from 2.8V to 14V
- ◆ $\pm 2.5\%$ Current-Monitoring Accuracy
- ◆ 1% Accurate 10-Bit ADC Monitors 12/8 Voltage Inputs
- ◆ Single-Ended or Differential ADC for System Voltage/Current Monitoring
- ◆ Integrated High-Side, Current-Sense Amplifier
- ◆ 12/8 Monitored Inputs with Overvoltage/Undervoltage/Early Warning Limit
- ◆ Nonvolatile Fault Event Logger
- ◆ Two Programmable Fault Outputs and One Reset Output
- ◆ Eight General-Purpose Inputs/Outputs Configurable as:
 - Dedicated Fault Outputs
 - Watchdog Timer Function
 - Manual Reset
 - Margin Enable
- ◆ SMBus (with Timeout) or JTAG Interface
- ◆ Flash Configurable Time Delays and Thresholds
- ◆ -40°C to $+85^{\circ}\text{C}$ Operating Temperature Range

Ordering Information

PART	TEMP RANGE	PIN-PACKAGE
MAX16070ETL+	-40°C to $+85^{\circ}\text{C}$	40 TQFN-EP*
MAX16071ETL+	-40°C to $+85^{\circ}\text{C}$	40 TQFN-EP*

+Denotes a lead(Pb)-free/RoHS-compliant package.

*EP = Exposed pad.

Pin Configuration and Typical Operating Circuits appear at end of data sheet.

12-Channel/8-Channel, Flash-Configurable System Managers with Nonvolatile Fault Registers

ABSOLUTE MAXIMUM RATINGS

V_{CC}, CSP, CSM to GND.....-0.3V to +15V
 CSP to CSM.....-0.7V to +0.7V
 MON_, GPIO_, SCL, SDA, A0, RESET to GND
 (programmed as open-drain outputs).....-0.3V to +6V
 EN, TCK, TMS, TDI to GND-0.3V to +4V
 DBP, ABP to GND....-0.3V to the lower of +3V and (V_{CC} + 0.3V)
 TDO, GPIO_, RESET
 (programmed as push-pull outputs) -0.3V to (V_{DBP} + 0.3V)

Input/Output Current20mA
 Continuous Power Dissipation (T_A = +70°C)
 40-Pin TQFN (derate 26.3mW/°C above +70°C).....2105mW
 Operating Temperature Range.....-40°C to +85°C
 Junction Temperature+150°C
 Storage Temperature Range.....-65°C to +150°C
 Lead Temperature (soldering, 10s)+300°C

Stresses beyond those listed under "Absolute Maximum Ratings" may cause permanent damage to the device. These are stress ratings only, and functional operation of the device at these or any other conditions beyond those indicated in the operational sections of the specifications is not implied. Exposure to absolute maximum rating conditions for extended periods may affect device reliability.

ELECTRICAL CHARACTERISTICS

(V_{CC} = 2.8V to 14V, T_A = -40°C to +85°C, unless otherwise specified. Typical values are at ABP = DBP = V_{CC} = 3.3V, T_A = +25°C.)
 (Note 1)

PARAMETER	SYMBOL	CONDITIONS	MIN	TYP	MAX	UNITS
Operating Voltage Range	V _{CC}	Reset output asserted low	1.2			V
		(Note 2)	2.8		14	
Undervoltage Lockout (Rising)	V _{UVLO}	Minimum voltage on V _{CC} to ensure the device is flash configurable			2.7	V
Undervoltage Lockout Hysteresis	V _{UVLO_HYS}			100		mV
Minimum Flash Operating Voltage	V _{flash}	Minimum voltage on V _{CC} to ensure flash erase and write operations	2.7			V
Supply Current	I _{CC}	No load on output pins		4.5	7	mA
		During flash writing cycle		10	14	
ABP Regulator Voltage	V _{ABP}	C _{ABP} = 1μF, no load, V _{CC} = 5V	2.85	3	3.15	V
DBP Regulator Voltage	V _{DBP}	C _{ABP} = 1μF, no load, V _{CC} = 5V	2.8	3	3.1	V
Boot Time	t _{BOOT}	V _{CC} > V _{UVLO}		200	350	μs
Flash Writing Time		8-byte word		122		ms
Internal Timing Accuracy		(Note 3)	-8		+8	%
EN Input Voltage	V _{TH_EN_R}	EN voltage rising		1.41		V
	V _{TH_EN_F}	EN voltage falling	1.365	1.39	1.415	
EN Input Current	I _{EN}		-0.5		+0.5	μA
Input Voltage Range			0		5.5	V

12-Channel/8-Channel, Flash-Configurable System Managers with Nonvolatile Fault Registers

ELECTRICAL CHARACTERISTICS (continued)

(V_{CC} = 2.8V to 14V, T_A = -40°C to +85°C, unless otherwise specified. Typical values are at ABP = DBP = V_{CC} = 3.3V, T_A = +25°C.) (Note 1)

PARAMETER	SYMBOL	CONDITIONS	MIN	TYP	MAX	UNITS	
ADC DC ACCURACY							
Resolution					10	Bits	
Gain Error	ADCGAIN	T _A = +25°C			0.35	%	
		T _A = -40°C to +85°C			0.70		
Offset Error	ADCOFF				1	LSB	
Integral Nonlinearity	ADCINL				1	LSB	
Differential Nonlinearity	ADC _{DNL}				1	LSB	
ADC Total Monitoring Cycle Time	t _{CYCLE}	No MON_ fault detected		40	50	μs	
ADC IN_ Ranges		1 LSB = 5.43mV		5.56		V	
		1 LSB = 2.72mV		2.78			
		1 LSB = 1.36mV		1.39			
CURRENT SENSE							
CSP Input-Voltage Range	VCSP		3		14	V	
Input Bias Current	ICSP			14	25	μA	
	ICSM	VCSP = VCSM		3	5		
CSP Total Unadjusted Error	CSPERR	(Note 4)			2	%FSR	
Overcurrent Differential Threshold	OVCTH	VCSP - VCSM	Gain = 48	21.5	25	30.5	mV
			Gain = 24	46	51	56	
			Gain = 12	94	101	108	
			Gain = 6	190	202	210	
V _{SENSE} Fault Threshold Hysteresis	OVCHYS			0.5		% OVCTH	
Secondary Overcurrent Threshold Timeout	OVCDL	r73h[6:5] = '00'		0		ms	
		r73h[6:5] = '01'	3	4	5		
		r73h[6:5] = '10'	12	16	20		
		r73h[6:5] = '11'	50	64	60		
V _{SENSE} Ranges			Gain = 6		232	mV	
			Gain = 12		116		
			Gain = 24		58		
			Gain = 48		29		
ADC Current Measurement Accuracy			V _{SENSE} = 150mV (gain = 6 only)	-2.5	±0.2	+2.5	%
			V _{SENSE} = 50mV, gain = 12	-4	±0.2	+4	
			V _{SENSE} = 25mV, gain = 24		±0.5		
			V _{SENSE} = 10mV, gain = 48		±1		
Gain Accuracy		V _{SENSE} = 20mV to 100mV, VCSP = 5V, gain = 6	-1.5		+1.5	%	
Common-Mode Rejection Ratio	CMRR _{SNS}	VCSP > 4V		80		dB	
Power-Supply Rejection Ratio	PSRR _{SNS}			80		dB	

www.DataSheet4U.com

12-Channel/8-Channel, Flash-Configurable System Managers with Nonvolatile Fault Registers

MAX16070/MAX16071

ELECTRICAL CHARACTERISTICS (continued)

(V_{CC} = 2.8V to 14V, T_A = -40°C to +85°C, unless otherwise specified. Typical values are at ABP = DBP = V_{CC} = 3.3V, T_A = +25°C.)
(Note 1)

PARAMETER	SYMBOL	CONDITIONS	MIN	TYP	MAX	UNITS
OUTPUTS (RESET, GPIO_)						
Output-Voltage Low	V _{OL}	I _{SINK} = 2mA			0.4	V
		I _{SINK} = 10mA, GPIO_ only			0.7	
		V _{CC} = 1.2V, I _{SINK} = 100μA (RESET only)			0.3	
Maximum Output Sink Current		Total current into RESET, GPIO_, V _{CC} = 3.3V			30	mA
Output-Voltage High (Push-Pull)		I _{SOURCE} = 100μA	2.4			V
Output Leakage (Open Drain)					1	μA
SMBus INTERFACE						
Logic-Input Low Voltage	V _{IL}	Input voltage falling			0.8	V
Logic-Input High Voltage	V _{IH}	Input voltage rising	2.0			V
Input Leakage Current		I _N = GND or V _{CC}	-1		+1	μA
Output Sink Current	V _{OL}	I _{SINK} = 3mA			0.4	V
Input Capacitance	C _{IN}			5		pF
SMBus Timeout	t _{TIMEOUT}	SCL time low for reset	25		35	ms
INPUTS (A0, GPIO_)						
Input Logic-Low	V _{IL}				0.8	V
Input Logic-High	V _{IH}		2.0			V
WDI Pulse Width	t _{WDI}		100			ns
MR Pulse Width	t _{MR}		1			μs
MR to RESET Delay				0.5		μs
MR Glitch Rejection				100		ns
SMBus TIMING						
Serial Clock Frequency	f _{SCL}				400	kHz
Bus Free Time Between STOP and START Condition	t _{BUF}		1.3			μs
START Condition Setup Time	t _{SU:STA}		0.6			μs
START Condition Hold Time	t _{HD:STA}		0.6			μs
STOP Condition Setup Time	t _{SU:STO}		0.6			μs
Clock Low Period	t _{LOW}		1.3			μs
Clock High Period	t _{HIGH}		0.6			μs
Data Setup Time	t _{SU:DAT}		100			ns

12-Channel/8-Channel, Flash-Configurable System Managers with Nonvolatile Fault Registers

ELECTRICAL CHARACTERISTICS (continued)

(V_{CC} = 2.8V to 14V, T_A = -40°C to +85°C, unless otherwise specified. Typical values are at ABP = DBP = V_{CC} = 3.3V, T_A = +25°C.) (Note 1)

PARAMETER	SYMBOL	CONDITIONS	MIN	TYP	MAX	UNITS
Output Fall Time	t _{OF}	CBUS = 10pF to 400pF			250	ns
Data Hold Time	t _{HD:DAT}	From 50% SCL falling to SDA change	0.3		0.9	μs
Pulse Width of Spike Suppressed	t _{SP}			30		ns
JTAG INTERFACE						
TDI, TMS, TCK Logic-Low Input Voltage	V _{IL}	Input voltage falling			0.8	V
TDI, TMS, TCK Logic-High Input Voltage	V _{IH}	Input voltage rising	2			V
TDO Logic-Output Low Voltage	V _{OL}	I _{SINK} = 3mA			0.4	V
TDO Logic-Output High Voltage	V _{OH}	I _{SOURCE} = 200μA	2.4			V
TDI, TMS Pullup Resistors	R _{PU}	Pullup to DBP	40	50	60	kΩ
I/O Capacitance	C _{I/O}			5		pF
TCK Clock Period	t ₁				1000	ns
TCK High/Low Time	t _{2, t3}		50	500		ns
TCK to TMS, TDI Setup Time	t ₄		15			ns
TCK to TMS, TDI Hold Time	t ₅		10			ns
TCK to TDO Delay	t ₆				500	ns
TCK to TDO High-Z Delay	t ₇				500	ns

Note 1: Specifications are guaranteed for the stated global conditions, unless otherwise noted. 100% production tested at T_A = +25°C and T_A = +85°C. Specifications at T_A = -40°C are guaranteed by design.

Note 2: For 3.3V V_{CC} applications, connect V_{CC}, DBP, and ABP together. For higher supply applications, connect V_{CC} only to the supply rail.

Note 3: Applies to RESET, fault, autoretry, sequence delays, and watchdog timeout.

Note 4: Total unadjusted error is a combination of gain, offset, and quantization error.

12-Channel/8-Channel, Flash-Configurable System Managers with Nonvolatile Fault Registers

MAX16070/MAX16071

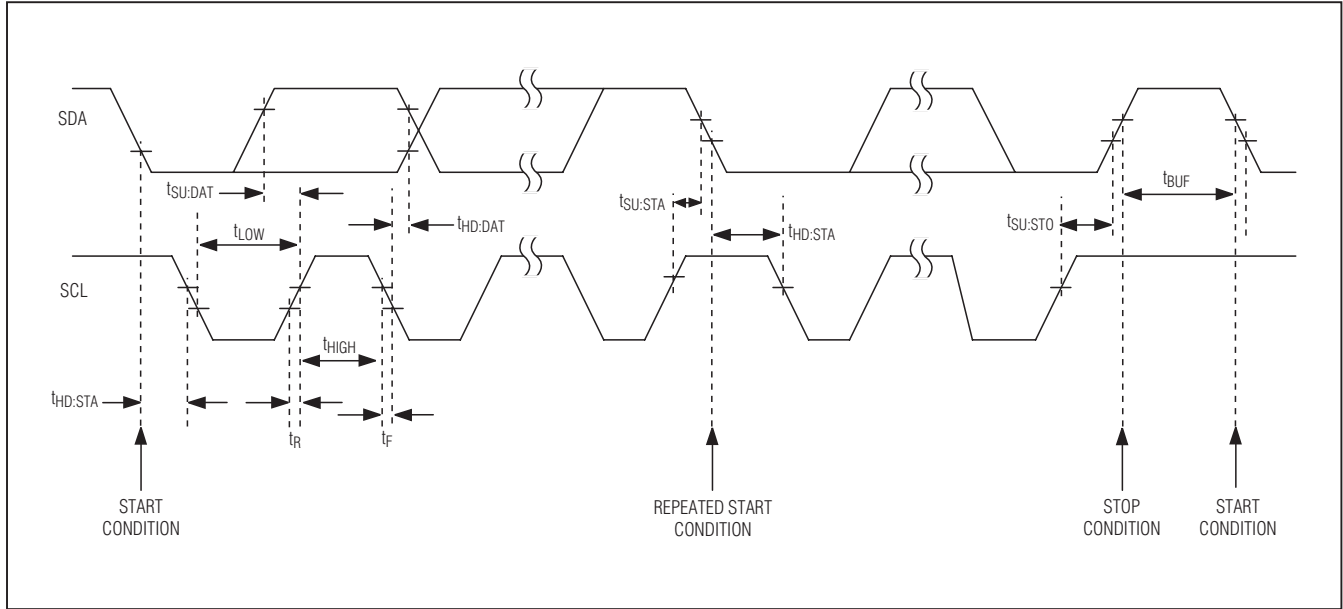

Figure 1. SMBus Timing Diagram

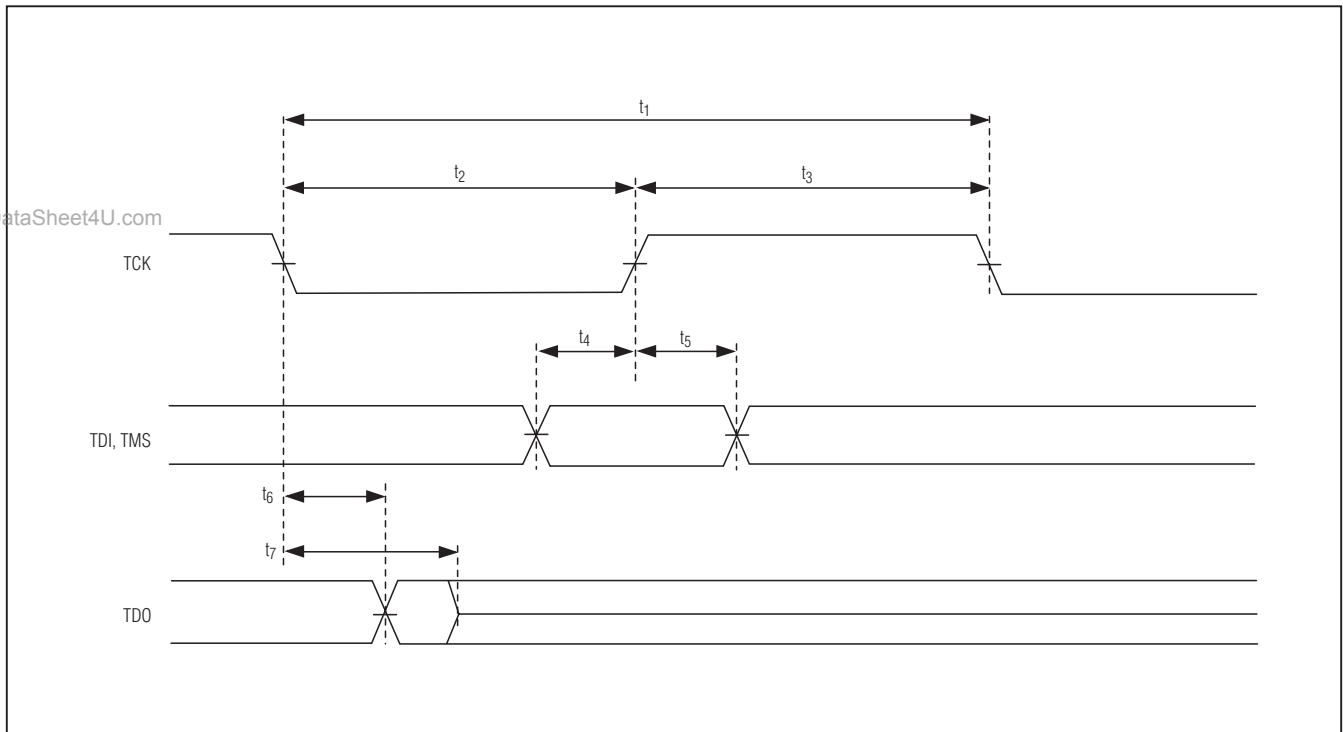
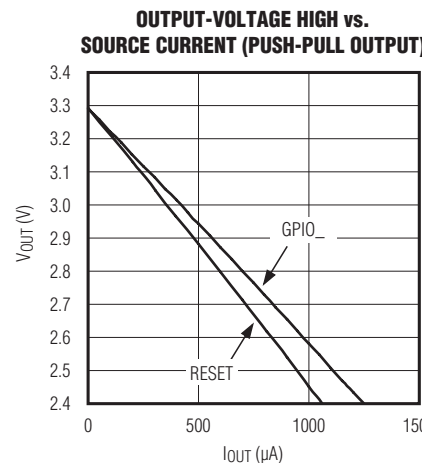
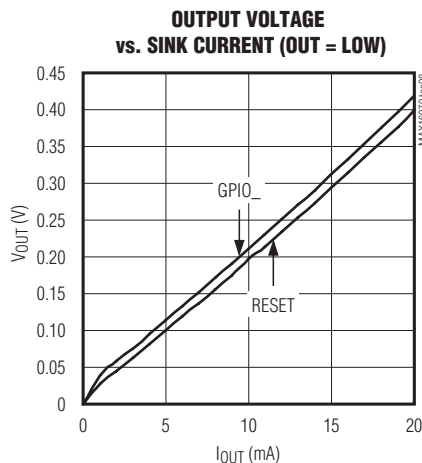
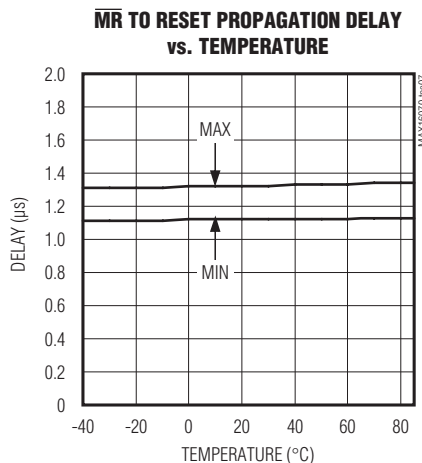
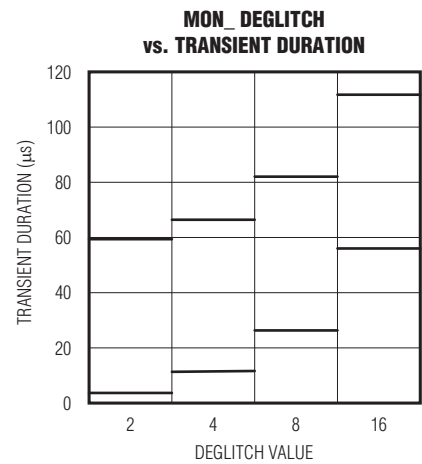
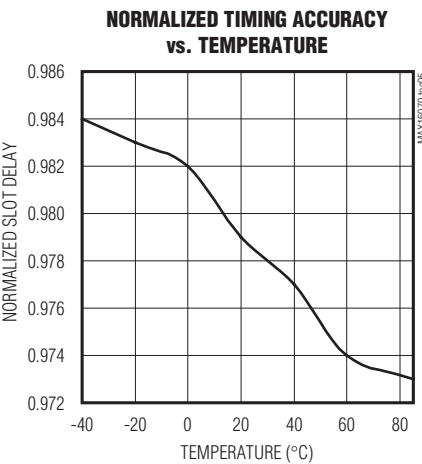
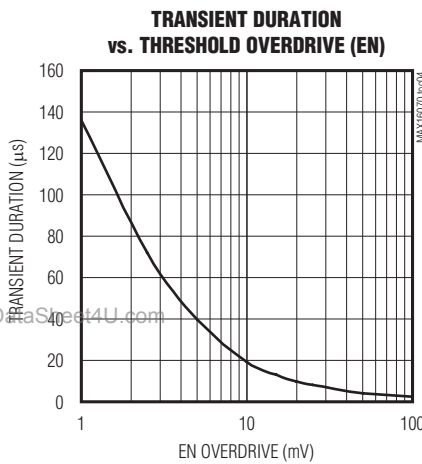
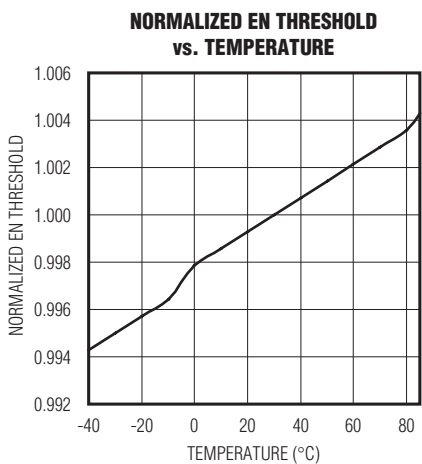
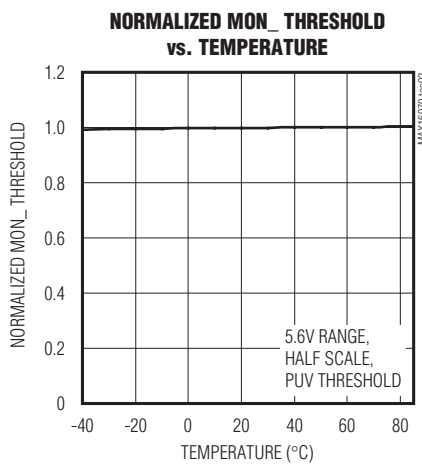
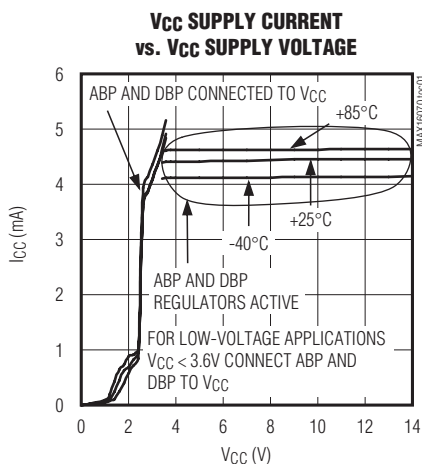

Figure 2. JTAG Timing Diagram

12-Channel/8-Channel, Flash-Configurable System Managers with Nonvolatile Fault Registers

Typical Operating Characteristics

(Typical values are at $V_{CC} = 3.3V$, $T_A = +25^\circ C$, unless otherwise noted.)



12-Channel/8-Channel Flash-Configurable System Monitors with Nonvolatile Fault Registers

Typical Operating Characteristics (continued)

(Typical values are at $V_{CC} = 3.3V$, $T_A = +25^\circ C$, unless otherwise noted.)

MAX16070/MAX16071

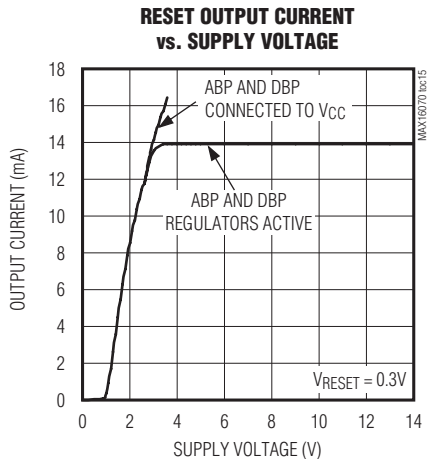
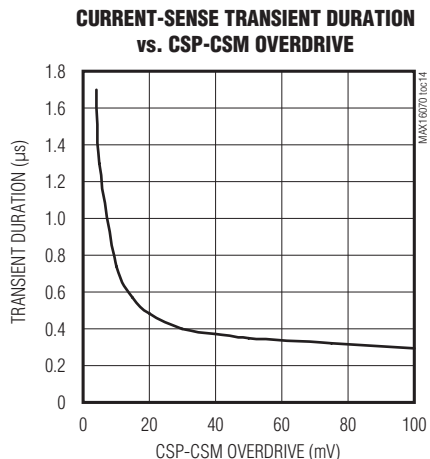
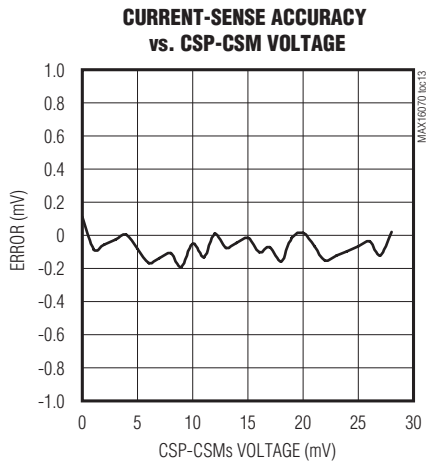
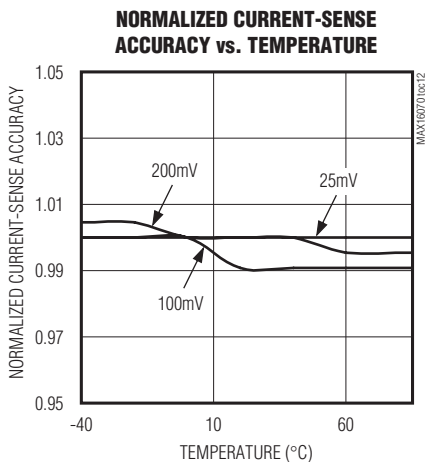
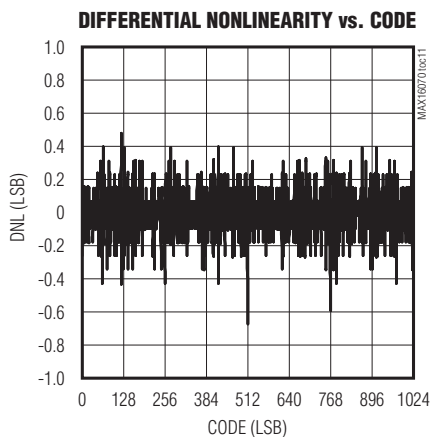
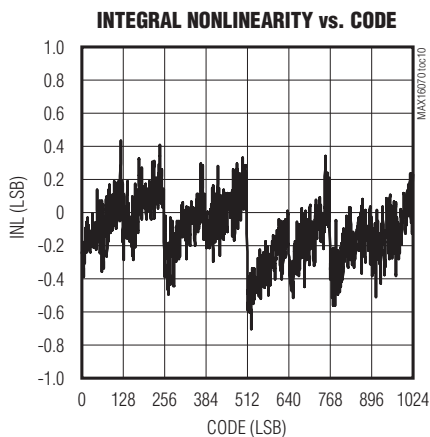

www.DataSheet4U.com

12-Channel/8-Channel, Flash-Configurable System Managers with Nonvolatile Fault Registers

Pin Description

MAX16070/MAX16071

PIN		NAME	FUNCTION
MAX16070	MAX16071		
1–5, 34, 35, 40	1–5, 37, 38, 40	MON2–MON6, MON7, MON8, MON1	Monitor Voltage Input 1–Monitor Voltage Input 8. Set monitor voltage range through configuration registers. Measured value written to the ADC register can be read back through the SMBus or JTAG interface.
6	6	CSP	Current-Sense Amplifier Positive Input. Connect CSP to the source side of the external sense resistor.
7	7	CSM	Current-Sense Amplifier Negative Input. Connect CSM to the load side of the external sense resistor.
8	8	RESET	Configurable Reset Output
9	9	TMS	JTAG Test Mode Select
10	10	TDI	JTAG Test Data Input
11	11	TCK	JTAG Test Clock
12	12	TDO	JTAG Test Data Output
13	13	SDA	SMBus Serial-Data Open-Drain Input/Output
14	14	A0	Four-State SMBus Address. Address sampled upon POR.
15	15	SCL	SMBus Serial Clock Input
16, 33	16, 36	GND	Ground
17, 18	—	GPIO7, GPIO8	General-Purpose Input/Output 7 and General-Purpose Input/Output 8. GPIO_s can be configured to act as a TTL input, a push-pull, open-drain, or high-impedance output or a pulldown circuit during a fault event or reverse sequencing.
19–24	17–22	GPIO1–GPIO6	General-Purpose Input/Output 1–General-Purpose Input/Output 6. GPIO_s can be configured to act as a TTL input, a push-pull, open-drain, or high-impedance output or a pulldown circuit during a fault event.
25, 26, 27, 29	23–28, 30, 39	N.C.	No Connection. Not internally connected.
28	29	EN	Analog Enable Input. All outputs deassert when V _{EN} is below the enable threshold.
30	31, 32	DBP	Digital Bypass. All push-pull outputs are referenced to DBP. Bypass DBP with a 1μF capacitor to GND.
31	33, 34	V _{CC}	Device Power Supply. Connect V _{CC} to a voltage from 2.8V to 14V. Bypass V _{CC} with a 10μF capacitor to GND.
32	35	ABP	Analog Bypass. Bypass ABP with a 1μF ceramic capacitor to GND.
36–39	—	MON9–MON12	Monitor Voltage Input 9–Monitor Voltage Input 12. Set monitor voltage range through configuration registers. Measured value written to the ADC register can be read back through the SMBus or JTAG interface.
—	—	EP	Exposed Pad. Internally connected to GND. Connect to ground, but do not use as the main ground connection.

www.DataSheet4U.com

12-Channel/8-Channel, Flash-Configurable System Managers with Nonvolatile Fault Registers

Functional Diagram

MAX16070/MAX16071

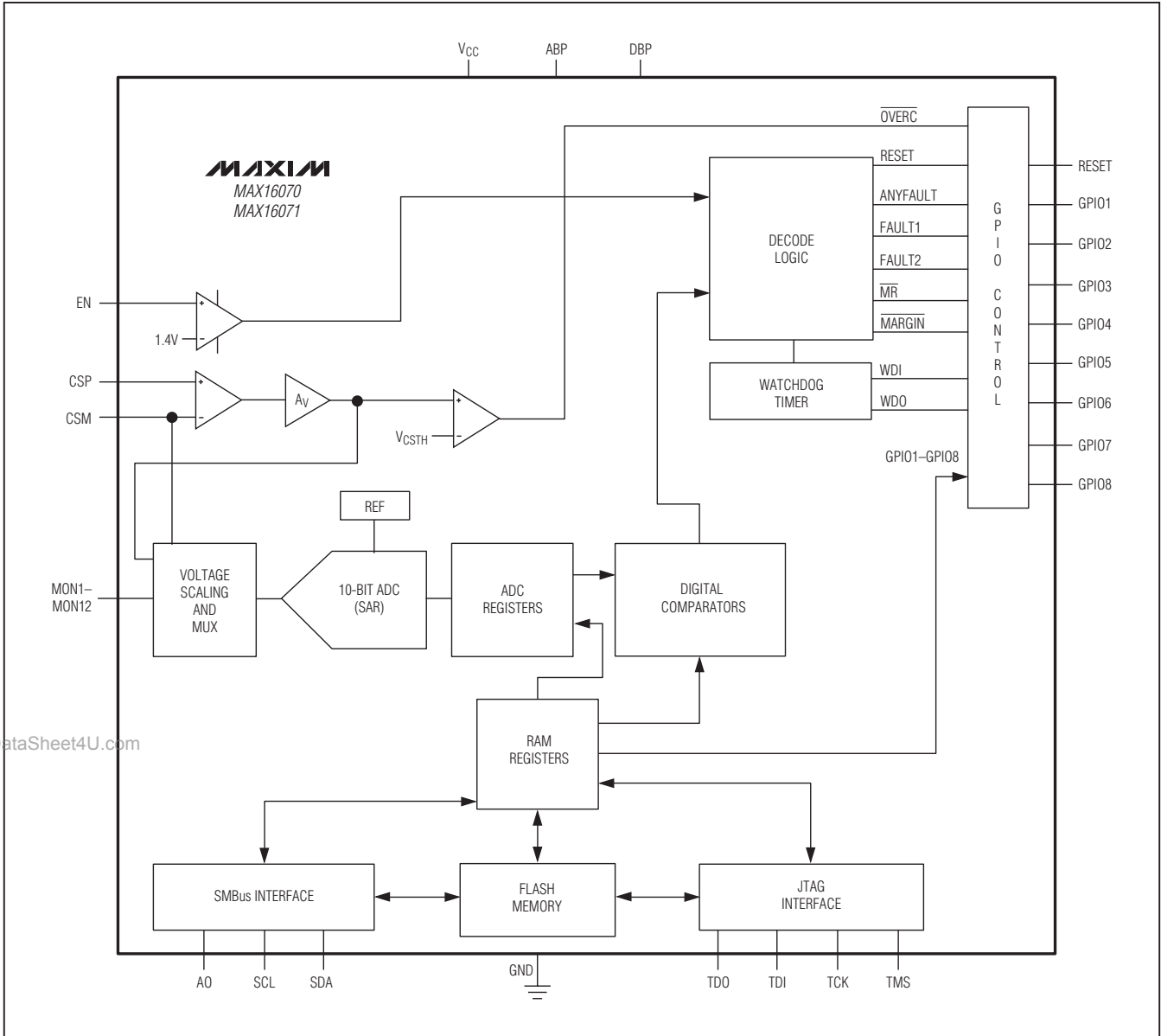

www.DataSheet4U.com

12-Channel/8-Channel, Flash-Configurable System Managers with Nonvolatile Fault Registers

Detailed Description

The MAX16070 monitors up to twelve system power supplies and the MAX16071 can monitor up to eight system power supplies. After boot-up, if EN is high and the software enable bit is set to '1,' monitoring begins based on the configuration stored in flash. An internal multiplexer cycles through each MON_ input. At each multiplexer stop, the 10-bit ADC converts the monitored analog voltage to a digital result and stores the result in a register. Each time a conversion cycle (50 μ s, max) completes, internal logic circuitry compares the conversion results to the overvoltage and undervoltage thresholds stored in memory. When a result violates a programmed threshold, the conversion can be configured to generate a fault. GPIO_ can be programmed to assert on combinations of faults. Additionally, faults can be configured to shut off the system and trigger the nonvolatile fault logger, which writes all fault information automatically to the flash and write-protects the data to prevent accidental erasure.

The MAX16070/MAX16071 contain both SMBus and JTAG serial interfaces for accessing registers and flash. Use only one interface at any given time. For more information on how to access the internal memory through these interfaces, see the *SMBus-Compatible Interface* and *JTAG Serial Interface* sections. The memory map is divided into three pages with access controlled by special SMBus and JTAG commands.

The factory-default values at POR (power-on reset) for all RAM registers are '0's. POR occurs when VCC reaches the undervoltage-lockout threshold (UVLO) of 2.8V (max). At POR, the device begins a boot-up sequence. During the boot-up sequence, all monitored inputs are masked

from initiating faults and flash contents are copied to the respective register locations. During boot-up, the MAX16070/MAX16071 are not accessible through the serial interface. The boot-up sequence takes up to 150 μ s, after which the device is ready for normal operation. RESET is asserted low up to the boot-up phase and remains asserted for its programmed timeout period once sequencing is completed and all monitored channels are within their respective thresholds. Up to the boot-up phase, the GPIO_s are high impedance.

Power

Apply 2.8V to 14V to VCC to power the MAX16070/MAX16071. Bypass VCC to ground with a 10 μ F capacitor. Two internal voltage regulators, ABP and DBP, supply power to the analog and digital circuitry within the device. For operation at 3.6V or lower, disable the regulators by connecting ABP and DBP to VCC.

ABP is a 3.0V (typ) voltage regulator that powers the internal analog circuitry. Bypass ABP to GND with a 1 μ F ceramic capacitor installed as close to the device as possible.

DBP is an internal 3.0V (typ) voltage regulator. DBP powers flash and digital circuitry. All push-pull outputs refer to DBP. Bypass the DBP output to GND with a 1 μ F ceramic capacitor installed as close as possible to the device.

Do not power external circuitry from ABP or DBP.

Enable

To enable monitoring, the voltage at EN must be above 1.4V and the software enable bit in r73h[0] must be set to '1.' To power down and disable monitoring, either pull EN below 1.35V or set the Software Enable bit to '0.' See Table 1 for the software enable bit configurations. Connect EN to ABP if not used.

Table 1. Software Enable Configurations

REGISTER ADDRESS	FLASH ADDRESS	BIT RANGE	DESCRIPTION
73h	273h	[0]	Software enable
		[1]	Reserved
		[2]	1 = Margin mode enabled
		[3]	Early warning threshold select 0 = Early warning is undervoltage 1 = Early warning is overvoltage
		[4]	Independent watchdog mode enable 1 = Watchdog timer is independent of sequencer 0 = Watchdog timer boots after sequence completes

12-Channel/8-Channel, Flash-Configurable System Managers with Nonvolatile Fault Registers

MAX16070/MAX16071

When in the monitoring state, a register bit, ENRESET, is set to a '1' when EN falls below the undervoltage threshold. This register bit latches and must be cleared through software. This bit indicates if RESET asserted low due to EN going under the threshold. The POR state of ENRESET is '0'. The bit is only set on a falling edge of the EN comparator output or the software enable bit.

Voltage/Current Monitoring

The MAX16070/MAX16071 feature an internal 10-bit ADC that monitors the MON_ voltage inputs. An internal multiplexer cycles through each of the enabled inputs, taking less than 40 μ s for a complete monitoring cycle. Each acquisition takes approximately 3.2 μ s. At each multiplexer stop, the 10-bit ADC converts the analog input to a digital result and stores the result in a register. ADC conversion results are stored in registers r00h to r1Ah (see Table 6). Use the SMBus or JTAG serial interface to read ADC conversion results.

The MAX16070 provides twelve inputs, MON1 to MON12, for voltage monitoring. The MAX16071 provides eight inputs, MON1 to MON8, for voltage monitoring. Each input voltage range is programmable in registers r43h to r45h (see Table 5). When MON_ configuration registers are set to '11,' MON_ voltages are not monitored, and the multiplexer does not stop at these inputs, decreasing the total cycle time. These inputs cannot be configured to trigger fault conditions.

The three programmable thresholds for each monitored voltage include an overvoltage, an undervoltage, and a secondary warning threshold that can be set in r73h[3] to be either an undervoltage or overvoltage threshold. See the *Faults* section for more information on setting overvoltage and undervoltage thresholds. All voltage thresholds are 8 bits wide. The 8 MSBs of the 10-bit ADC conversion result are compared to these overvoltage and undervoltage thresholds.

Inputs that are not enabled are not converted by the ADC; they contain the last value acquired before that channel was disabled.

The ADC conversion result registers are reset to 00h at boot-up. These registers are not reset when a reboot command is executed.

Configure the MAX16070/MAX16071 for differential mode in r46h (Table 5). The possible differential pairs are MON1/MON2, MON3/MON4, MON5/MON6, MON7/MON8, MON9/MON10, MON11/MON12 with the first input always being at a higher voltage than the second. Use differential voltage sensing to eliminate voltage offsets or measure supply current. See Figure 3. In differential mode, the odd-numbered MON_ input measures the absolute voltage with respect to GND while the result of the even input is the difference between the odd and even inputs. See Figure 3 for the typical differential measurement circuit.

www.DataSheet4U.com

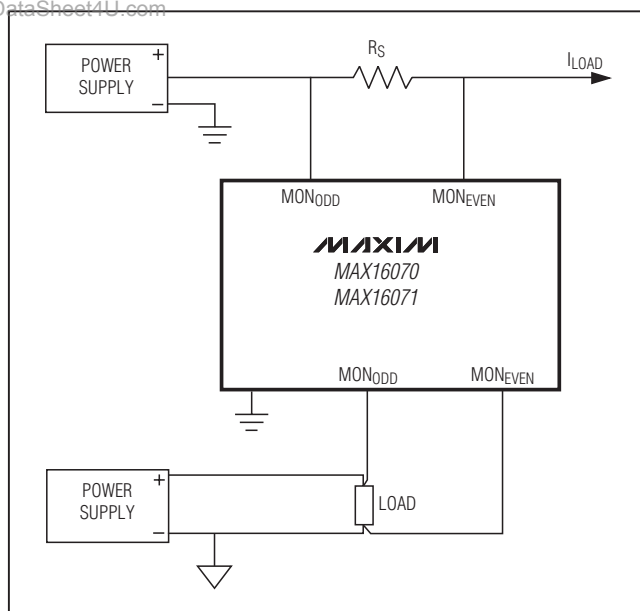

Figure 3. Differential Measurement Connections

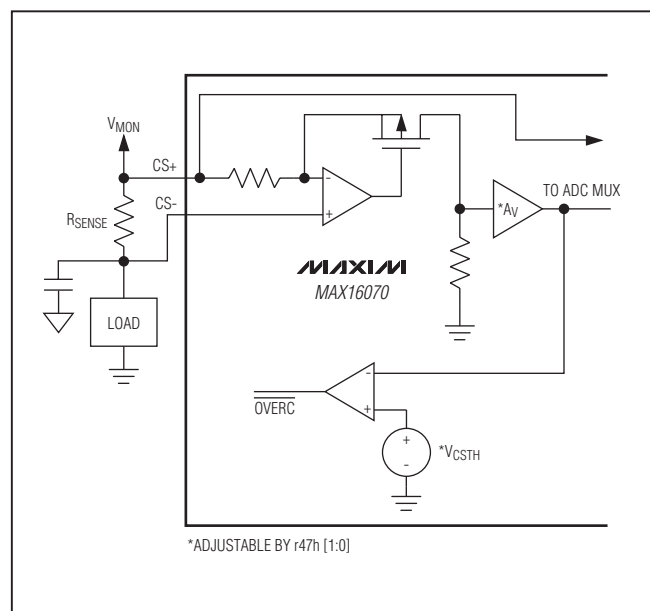

Figure 4. Current-Sense Amplifier

12-Channel/8-Channel, Flash-Configurable System Managers with Nonvolatile Fault Registers

Boot-Up Delay

Once EN is above its threshold and the software-enable bit is set, a boot-up delay occurs before monitoring begins. This delay is configured in register 77h[3:0] as shown in Tables 2 and 3.

Internal Current-Sense Amplifier

The current-sense inputs, CSP/CSM, and a current-sense amplifier facilitate power monitoring (see Figure 4). The voltage on CSP relative to GND is also monitored by the ADC when the current-sense amplifier is enabled with r47h[0]. The conversion results are located in registers r19h and r1Ah (see Table 6). There are two selectable voltage ranges for CSP set by r47h[1], see Table 4. Although the voltage can be monitored over SMBus or JTAG, this voltage has no threshold comparators and cannot trigger any faults. Regarding the current-sense amplifier, there are four selectable ranges and the ADC output for a current-sense conversion is:

$$X_{ADC} = (V_{SENSE} \times A_V) / 1.4V \times (2^8 - 1)$$

where X_{ADC} is the 8-bit decimal ADC result in register r18h, V_{SENSE} is $V_{CSP} - V_{CSM}$, and A_V is the current-sense voltage gain set by r47h[3:2].

In addition, there are two programmable current-sense trip thresholds: primary overcurrent and secondary overcurrent. For fast fault detection, the primary overcurrent threshold is implemented with an analog comparator connected to the internal \overline{OVERC} signal. The \overline{OVERC} signal can be output on one of the GPIO_s. See the *General-Purpose Inputs/Outputs* section for configuring the GPIO_ to output the \overline{OVERC} signal. The primary threshold is set by:

$$I_{TH} = V_{CSTH} / R_{SENSE}$$

where I_{TH} is the current threshold to be set, V_{CSTH} is the threshold set by r47h[3:2], and R_{SENSE} is the value of the sense resistor. See Table 4 for a description of r47h. \overline{OVERC} depends only on the primary overcurrent threshold. The secondary overcurrent threshold is implemented through ADC conversions and digital comparison set by r6Ch. The secondary overcurrent threshold includes programmable time delay options located in r73h[6:5]. Primary and secondary current-sense faults are enabled/disabled through r47h[0].

Table 2. Boot-Up Delay Register

REGISTER ADDRESS	FLASH ADDRESS	BIT RANGE	DESCRIPTION
77h	277h	[3:0]	Boot-up delay
		[7:0]	Reserved

www.DataSheet4U.com

Table 3. Boot-Up Delay Values

CODE	VALUE
0000	25μs
0001	500μs
0010	1ms
0011	2ms
0100	3ms
0101	4ms
0110	6ms
0111	8ms
1000	10ms
1001	12ms
1010	25ms
1011	100ms
1100	200ms
1101	400ms
1110	800ms
1111	1.6s

12-Channel/8-Channel, Flash-Configurable System Managers with Nonvolatile Fault Registers

MAX16070/MAX16071 Table 4. Overcurrent Primary Threshold and Current-Sense Control

REGISTER ADDRESS	FLASH ADDRESS	BIT RANGE	DESCRIPTION
47h	247h	[0]	1 = Current sense is enabled 0 = Current sense is disabled
		[1]	1 = CSP full-scale range is 14V 0 = CSP full-scale range is 7V
		[3:2]	Overcurrent primary threshold and current-sense gain setting 00 = 200mV threshold, AV = 6V/V 01 = 100mV threshold, AV = 12V/V 10 = 50mV threshold, AV = 24V/V 11 = 25mV threshold, AV = 48V/V
73h	273h	[6:5]	Overcurrent secondary threshold deglitch 00 = No delay 01 = 14ms 10 = 15ms 11 = 60ms

Table 5. ADC Configuration Registers

REGISTER ADDRESS	FLASH ADDRESS	BIT RANGE	DESCRIPTION
43h	243h	[1:0]	ADC1 full-scale range 00 = 5.6V 01 = 2.8V 10 = 1.4V 11 = Channel not converted
		[3:2]	ADC2 full-scale range 00 = 5.6V 01 = 2.8V 10 = 1.4V 11 = Channel not converted
		[5:4]	ADC3 full-scale range 00 = 5.6V 01 = 2.8V 10 = 1.4V 11 = Channel not converted
		[7:6]	ADC4 full-scale range 00 = 5.6V 01 = 2.8V 10 = 1.4V 11 = Channel not converted

12-Channel/8-Channel, Flash-Configurable System Managers with Nonvolatile Fault Registers

Table 5. ADC Configuration Registers (continued)

REGISTER ADDRESS	FLASH ADDRESS	BIT RANGE	DESCRIPTION
44h	244h	[1:0]	ADC5 full-scale range 00 = 5.6V 01 = 2.8V 10 = 1.4V 11 = Channel not converted
		[3:2]	ADC6 full-scale range 00 = 5.6V 01 = 2.8V 10 = 1.4V 11 = Channel not converted
		[5:4]	ADC7 full-scale range 00 = 5.6V 01 = 2.8V 10 = 1.4V 11 = Channel not converted
		[7:6]	ADC8 full-scale range 00 = 5.6V 01 = 2.8V 10 = 1.4V 11 = Channel not converted
45h	245h	[1:0]	ADC9 full-scale range 00 = 5.6V 01 = 2.8V 10 = 1.4V 11 = Channel not converted
		[3:2]	ADC10 full-scale range 00 = 5.6V 01 = 2.8V 10 = 1.4V 11 = Channel not converted
		[5:4]	ADC11 full-scale range 00 = 5.6V 01 = 2.8V 10 = 1.4V 11 = Channel not converted
		[7:6]	ADC12 full-scale range 00 = 5.6V 01 = 2.8V 10 = 1.4V 11 = Channel not converted

www.DataSheet4U.com

12-Channel/8-Channel, Flash-Configurable System Managers with Nonvolatile Fault Registers

Table 5. ADC Configuration Registers (continued)

REGISTER ADDRESS	FLASH ADDRESS	BIT RANGE	DESCRIPTION
46h	246h	[0]	Differential conversion ADC1, ADC2 0 = Disabled 1 = Enabled
		[1]	Differential conversion ADC3, ADC4 0 = Disabled 1 = Enabled
		[2]	Differential conversion ADC5, ADC6 0 = Disabled 1 = Enabled
		[3]	Differential conversion ADC7, ADC8 0 = Disabled 1 = Enabled
		[4]	Differential conversion ADC9, ADC10 0 = Disabled 1 = Enabled
		[5]	Differential conversion ADC11, ADC12 0 = Disabled 1 = Enabled

12-Channel/8-Channel, Flash-Configurable System Managers with Nonvolatile Fault Registers

Table 6. ADC Conversion Results (Read Only)

REGISTER ADDRESS	BIT RANGE	DESCRIPTION
00h	[7:0]	ADC1 result (MSB) bits 9–2
01h	[7:6]	ADC1 result (LSB) bits 1, 0
02h	[7:0]	ADC2 result (MSB) bits 9–2
03h	[7:6]	ADC2 result (LSB) bits 1, 0
04h	[7:0]	ADC3 result (MSB) bits 9–2
05h	[7:6]	ADC3 result (LSB) bits 1, 0
06h	[7:0]	ADC4 result (MSB) bits 9–2
07h	[7:6]	ADC4 result (LSB) bits 1, 0
08h	[7:0]	ADC5 result (MSB) bits 9–2
09h	[7:6]	ADC5 result (LSB) bits 1, 0
0Ah	[7:0]	ADC6 result (MSB) bits 9–2
0Bh	[7:6]	ADC6 result (LSB) bits 1, 0
0Ch	[7:0]	ADC7 result (MSB) bits 9–2
0Dh	[7:6]	ADC7 result (LSB) bits 1, 0
0Eh	[7:0]	ADC8 result (MSB) bits 9–2
0Fh	[7:6]	ADC8 result (LSB) bits 1, 0
10h	[7:0]	ADC9 result (MSB) bits 9–2
11h	[7:6]	ADC9 result (LSB) bits 1, 0
12h	[7:0]	ADC10 result (MSB) bits 9–2
13h	[7:6]	ADC10 result (LSB) bits 1, 0
14h	[7:0]	ADC11 result (MSB) bits 9–2
15h	[7:6]	ADC11 result (LSB) bits 1, 0
16h	[7:0]	ADC12 result (MSB) bits 9–2
17h	[7:6]	ADC12 result (LSB) bits 1, 0
18h	[7:0]	Current-sense ADC result
19h	[7:0]	CSP ADC output (MSB) bits 9–2
1Ah	[7:6]	CSP ADC output (LSB) bits 1, 0

12-Channel/8-Channel, Flash-Configurable System Managers with Nonvolatile Fault Registers

General-Purpose Inputs/Outputs

GPIO1 to GPIO8 are programmable general-purpose inputs/outputs. GPIO1–GPIO8 are configurable as a manual reset input, a watchdog timer input and output, logic inputs/outputs, fault-dependent outputs. When programmed as outputs, GPIO_s are open drain or push-pull. See Tables 8 and 9 for more detailed information on configuring GPIO1 to GPIO8.

When GPIO1 to GPIO8 are configured as general-purpose inputs/outputs, read values from the GPIO_ ports through r1Eh and write values to GPIO_s through r3Eh. Note that r3Eh has a corresponding flash register, which programs the default state of a general-purpose output. See Table 7 for more information on reading and writing to the GPIO_.

Table 7. GPIO_ State Registers

REGISTER ADDRESS	FLASH ADDRESS	BIT RANGE	DESCRIPTION
1Eh	—	[0]	GPIO1 input state
		[1]	GPIO2 input state
		[2]	GPIO3 input state
		[3]	GPIO4 input state
		[4]	GPIO5 input state
		[5]	GPIO6 input state
		[6]	GPIO7 input state
		[7]	GPIO8 input state
3Eh	23Eh	[0]	GPIO1 output state
		[1]	GPIO2 output state
		[2]	GPIO3 output state
		[3]	GPIO4 output state
		[4]	GPIO5 output state
		[5]	GPIO6 output state
		[6]	GPIO7 output state
		[7]	GPIO8 output state

Table 8. GPIO_ Configuration Registers

REGISTER ADDRESS	FLASH ADDRESS	BIT RANGE	DESCRIPTION
3Fh	23Fh	[2:0]	GPIO1 configuration
		[5:3]	GPIO2 configuration
		[7:6]	GPIO3 configuration (LSB)
40h	240h	[0]	GPIO3 configuration (MSB)
		[3:1]	GPIO4 configuration
		[6:4]	GPIO5 configuration
41h	241h	[7]	GPIO6 configuration (LSB)
		[1:0]	GPIO6 configuration (MSB)
		[4:2]	GPIO7 configuration
		[7:5]	GPIO8 configuration

12-Channel/8-Channel, Flash-Configurable System Managers with Nonvolatile Fault Registers

Table 8. GPIO_ Configuration Registers (continued)

REGISTER ADDRESS	FLASH ADDRESS	BIT RANGE	DESCRIPTION
42h	242h	[0]	Output configuration for GPIO1 0 = Push-pull 1 = Open drain
		[1]	Output configuration for GPIO2 0 = Push-pull 1 = Open drain
		[2]	Output configuration for GPIO3 0 = Push-pull 1 = Open drain
		[3]	Output configuration for GPIO4 0 = Push-pull 1 = Open drain
		[4]	Output configuration for GPIO5 0 = Push-pull 1 = Open drain
		[5]	Output configuration for GPIO6 0 = Push-pull 1 = Open drain
		[6]	Output configuration for GPIO7 0 = Push-pull 1 = Open drain
		[7]	Output configuration for GPIO8 0 = Push-pull 1 = Open drain

www.DataSheet4U.com

Table 9. GPIO_ Function Configuration Bits

CODE	GPIO1	GPIO2	GPIO3	GPIO4	GPIO5	GPIO6	GPIO7	GPIO8
000	Logic input	Logic input	Logic input	Logic input	Logic input	Logic input	Logic input	Logic input
001	Logic output	Logic output	Logic output	Logic output	Logic output	Logic output	Logic output	Logic output
010	Fault2 output	Fault2 output	Fault2 output	Fault2 output	Fault2 output	Fault2 output	Fault2 output	Fault2 output
011	Fault1 output	Fault1 output	—	Fault1 output	Fault1 output	Fault1 output	Fault1 output	$\overline{\text{FAULT}}$ output
100	$\overline{\text{ANY_FAULT}}$ output	—	$\overline{\text{ANY_FAULT}}$ output	$\overline{\text{ANY_FAULT}}$ output	$\overline{\text{ANY_FAULT}}$ output	—	$\overline{\text{ANY_FAULT}}$ output	—
101	$\overline{\text{OVERC}}$ output	$\overline{\text{OVERC}}$ output	$\overline{\text{OVERC}}$ output	$\overline{\text{OVERC}}$ output	$\overline{\text{OVERC}}$ output	$\overline{\text{OVERC}}$ output	$\overline{\text{OVERC}}$ output	$\overline{\text{OVERC}}$ output
110	$\overline{\text{MR}}$ input	$\overline{\text{WDO}}$ output	$\overline{\text{MR}}$ input	$\overline{\text{WDO}}$ output	$\overline{\text{MR}}$ input	$\overline{\text{WDO}}$ output	$\overline{\text{MR}}$ input	$\overline{\text{WDO}}$ output
111	WDI input	—	—	$\overline{\text{EXTFAULT}}$ input/output	—	MARGIN input	—	$\overline{\text{EXTFAULT}}$ input/output

12-Channel/8-Channel, Flash-Configurable System Managers with Nonvolatile Fault Registers

Fault1 and Fault2

GPIO1 to GPIO8 are configurable as dedicated fault outputs, Fault1 or Fault2. Fault outputs can assert on one or more overvoltage, undervoltage, or early warning conditions for selected inputs, as well as the secondary over-current comparator. Fault1 and Fault2 dependencies

are set using registers r36h to r3Ah. See Table 10. When a fault output depends on more than one MON_, the fault output asserts when one or more MON_ exceeds a programmed threshold voltage. These fault outputs act independently of the critical fault system, described in the *Critical Faults* section.

Table 10. Fault1 and Fault2 Dependencies

REGISTER ADDRESS	FLASH ADDRESS	BIT RANGE	DESCRIPTION
36h	236h	0	1 = Fault1 depends on MON1
		1	1 = Fault1 depends on MON2
		2	1 = Fault1 depends on MON3
		3	1 = Fault1 depends on MON4
		4	1 = Fault1 depends on MON5
		5	1 = Fault1 depends on MON6
		6	1 = Fault1 depends on MON7
		7	1 = Fault1 depends on MON8
37h	237h	0	1 = Fault1 depends on MON9
		1	1 = Fault1 depends on MON10
		2	1 = Fault1 depends on MON11
		3	1 = Fault1 depends on MON12
		4	1 = Fault1 depends on the overvoltage thresholds of the inputs selected by r36h and r37h[3:0]
		5	1 = Fault1 depends on the undervoltage thresholds of the inputs selected by r36h and r37h[3:0]
		6	1 = Fault1 depends on the early warning thresholds of the inputs selected by r36h and r37h[3:0]
38h	238h	[0]	1 = Fault2 depends on MON1
		[1]	1 = Fault2 depends on MON2
		[2]	1 = Fault2 depends on MON3
		[3]	1 = Fault2 depends on MON4
		[4]	1 = Fault2 depends on MON5
		[5]	1 = Fault2 depends on MON6
		[6]	1 = Fault2 depends on MON7
		[7]	1 = Fault2 depends on MON8

MAX16070/MAX16071

www.DataSheet4U.com

12-Channel/8-Channel, Flash-Configurable System Managers with Nonvolatile Fault Registers

Table 10. Fault1 and Fault2 Dependencies (continued)

REGISTER ADDRESS	FLASH ADDRESS	BIT RANGE	DESCRIPTION
39h	239h	[0]	1 = Fault2 depends on MON9
		[1]	1 = Fault2 depends on MON10
		[2]	1 = Fault2 depends on MON11
		[3]	1 = Fault2 depends on MON12
		[4]	1 = Fault2 depends on the overvoltage thresholds of the inputs selected by r38h and r39h[3:0]
		[5]	1 = Fault2 depends on the undervoltage thresholds of the inputs selected by r38h and r39h[3:0]
		[6]	1 = Fault2 depends on the early warning thresholds of the inputs selected by r38h and r39h[3:0]
		[7]	0 = Fault2 is an active-low digital output 1 = Fault2 is an active-high digital output
3Ah	23Ah	[0]	1 = Fault1 depends on secondary overcurrent comparator
		[1]	1 = Fault2 depends on secondary overcurrent comparator
		[7:2]	Reserved

ANY_FAULT

GPIO1, GPIO3, GPIO4, GPIO5, and GPIO7 are configurable to assert low during any fault condition.

Overcurrent Comparator (\overline{OVERC})

GPIO1 to GPIO8 are configurable to assert low when the voltage across CSP and CSM exceed the primary overcurrent threshold. See the *Internal Current-Sense Amplifier* section for more details.

Manual Reset (\overline{MR})

GPIO1, GPIO3, GPIO5, and GPIO7 are configurable to act as an active-low manual reset input, \overline{MR} . Drive \overline{MR} low to assert RESET. RESET remains asserted for the selected reset timeout period after \overline{MR} transitions from low to high.

Watchdog Input (WDI) and Output (\overline{WDO})

GPIO2, GPIO4, GPIO6, and GPIO8 are configurable as the watchdog timer output, \overline{WDO} . GPIO1 is configurable as WDI. See Table 17 for configuration details. \overline{WDO} is an active-low output. See the *Watchdog Timer* section for more information about the operation of the watchdog timer.

External Fault ($\overline{EXTFAULT}$)

GPIO4 and GPIO8 are configurable as the external fault input/output. When configured as push-pull, $\overline{EXTFAULT}$ signals that a critical fault has occurred on one or more monitored voltages or current. When configured as open-drain, $\overline{EXTFAULT}$ can be asserted low by an external circuit to trigger a critical fault. This signal can be used to cascade multiple MAX16070/MAX16071s.

One configuration bit determines the behavior of the MAX16070/MAX16071 when $\overline{EXTFAULT}$ is pulled low by some other device. If register bit r6Dh[2] is set, $\overline{EXTFAULT}$ going low triggers a nonvolatile fault log operation.

Faults

The MAX16070/MAX16071 monitor the input (MON_) channels and compare the results with an overvoltage threshold, an undervoltage threshold, and a selectable overvoltage or undervoltage early warning threshold. Based on these conditions, the MAX16070/MAX16071 assert various fault outputs and save specific information about the channel conditions and voltages into the nonvolatile flash. Once a critical fault event occurs, the failing channel condition, ADC conversions at the time of the fault, or both can be saved by configuring the event logger. The event logger records a single failure in the internal flash and sets a lock bit that protects the stored fault data from accidental erasure on a subsequent power-up.

An overvoltage event occurs when the voltage at a monitored input exceeds the overvoltage threshold for that input. An undervoltage event occurs when the voltage at a monitored input falls below the undervoltage threshold. Fault thresholds are set in registers r48h to r6Ch as shown in Table 11. Disabled inputs are not monitored for fault conditions and are skipped over by the input multiplexer. Only the upper 8 bits of a conversion result are compared with the programmed fault thresholds.

12-Channel/8-Channel, Flash-Configurable System Managers with Nonvolatile Fault Registers

Table 11. Fault Threshold Registers

REGISTER ADDRESS	FLASH ADDRESS	BIT RANGE	DESCRIPTION
48h	248h	[7:0]	MON1 secondary threshold
49h	249h	[7:0]	MON1 overvoltage threshold
4Ah	24Ah	[7:0]	MON1 undervoltage threshold
4Bh	24Bh	[7:0]	MON2 secondary threshold
4Ch	24Ch	[7:0]	MON2 overvoltage threshold
4Dh	24Dh	[7:0]	MON2 undervoltage threshold
4Eh	24Eh	[7:0]	MON3 secondary threshold
4Fh	24Fh	[7:0]	MON3 overvoltage threshold
50h	250h	[7:0]	MON3 undervoltage threshold
51h	251h	[7:0]	MON4 secondary threshold
52h	252h	[7:0]	MON4 overvoltage threshold
53h	253h	[7:0]	MON4 undervoltage threshold
54h	254h	[7:0]	MON5 secondary threshold
55h	255h	[7:0]	MON5 overvoltage threshold
56h	256h	[7:0]	MON5 undervoltage threshold
57h	257h	[7:0]	MON6 secondary threshold
58h	258h	[7:0]	MON6 overvoltage threshold
59h	259h	[7:0]	MON6 undervoltage threshold
5Ah	25Ah	[7:0]	MON7 secondary threshold
5Bh	25Bh	[7:0]	MON7 overvoltage threshold
5Ch	25Ch	[7:0]	MON7 undervoltage threshold
5Dh	25Dh	[7:0]	MON8 secondary threshold
5Eh	25Eh	[7:0]	MON8 overvoltage threshold
5Fh	25Fh	[7:0]	MON8 undervoltage threshold
60h	260h	[7:0]	MON9 secondary threshold
61h	261h	[7:0]	MON9 overvoltage threshold
62h	262h	[7:0]	MON9 undervoltage threshold
63h	263h	[7:0]	MON10 secondary threshold
64h	264h	[7:0]	MON10 overvoltage threshold
65h	265h	[7:0]	MON10 undervoltage threshold
66h	266h	[7:0]	MON11 secondary threshold
67h	267h	[7:0]	MON11 overvoltage threshold
68h	268h	[7:0]	MON11 undervoltage threshold
69h	269h	[7:0]	MON12 secondary threshold
6Ah	26Ah	[7:0]	MON12 overvoltage threshold
6Bh	26Bh	[7:0]	MON12 undervoltage threshold
6Ch	26Ch	[7:0]	Secondary overcurrent threshold

MAX16070/MAX16071

www.DataSheet4U.com

12-Channel/8-Channel, Flash-Configurable System Managers with Nonvolatile Fault Registers

The general-purpose inputs/outputs (GPIO1 to GPIO8) can be configured as ANY_FAULT outputs or dedicated Fault1 and Fault2 outputs to indicate fault conditions. These fault outputs are not masked by the critical fault enable bits shown in Table 14. See the *General-Purpose Inputs/Outputs* section for more information on configuring GPIO_s as fault outputs.

Deglitch

Fault conditions are detected at the end of each conversion. When the voltage on an input falls outside a monitored threshold for one acquisition, the input multiplexer remains on that channel and performs several successive conversions. To trigger a fault, the input must stay

outside the threshold for a certain number of acquisitions as determined by the deglitch setting in r73h[6:5] and r74h[6:5] (see Table 12).

Fault Flags

Fault flags indicate the fault status of a particular input. The fault flag of any monitored input in the device can be read at any time from registers r1Bh and r1Ch, as shown in Table 13. Clear a fault flag by writing a '1' to the appropriate bit in the flag register. Unlike the fault signals sent to the fault outputs, these bits are masked by the Critical Fault Enable bits (see Table 14). The fault flag is only set when the matching enable bit in the critical fault enable register is also set.

Table 12. Deglitch Configuration

REGISTER ADDRESS	FLASH ADDRESS	BIT RANGE	DESCRIPTION
73h	273h	[6:5]	Overcurrent comparator deglitch time 00 = No deglitch 01 = 4ms 10 = 15ms 11 = 60ms
74h	274h	[6:5]	Voltage comparator deglitch configuration 00 = 2 cycles 01 = 4 cycles 10 = 8 cycles 11 = 16 cycles

www.DataSheet4U.com

Table 13. Fault Flags

REGISTER ADDRESS	BIT RANGE	DESCRIPTION
1Bh	[0]	MON1
	[1]	MON2
	[2]	MON3
	[3]	MON4
	[4]	MON5
	[5]	MON6
	[6]	MON7
	[7]	MON8
1Ch	[0]	MON9
	[1]	MON10
	[2]	MON11
	[3]	MON12
	[4]	Overcurrent
	[5]	External fault (EXTFAULT)
	[6]	SMB alert

12-Channel/8-Channel, Flash-Configurable System Managers with Nonvolatile Fault Registers

Table 14. Critical Fault Configuration

REGISTER ADDRESS	FLASH ADDRESS	BIT RANGE	DESCRIPTION
6Dh	26Dh	[1:0]	Fault information to log 00 = Save failed line flags and ADC values in flash 01 = Save only failed line flags in flash 10 = Save only ADC values in flash 11 = Do not save anything
		[2]	1 = Fault log triggered when EXTFAULT is pulled low externally
		[7:3]	Not used
6Eh	26Eh	[0]	1 = Fault log triggered when MON1 is below its undervoltage threshold
		[1]	1 = Fault log triggered when MON2 is below its undervoltage threshold
		[2]	1 = Fault log triggered when MON3 is below its undervoltage threshold
		[3]	1 = Fault log triggered when MON4 is below its undervoltage threshold
		[4]	1 = Fault log triggered when MON5 is below its undervoltage threshold
		[5]	1 = Fault log triggered when MON6 is below its undervoltage threshold
		[6]	1 = Fault log triggered when MON7 is below its undervoltage threshold
		[7]	1 = Fault log triggered when MON8 is below its undervoltage threshold
6Fh	26Fh	[0]	1 = Fault log triggered when MON9 is below its undervoltage threshold
		[1]	1 = Fault log triggered when MON10 is below its undervoltage threshold
		[2]	1 = Fault log triggered when MON11 is below its undervoltage threshold
		[3]	1 = Fault log triggered when MON12 is below its undervoltage threshold
		[4]	1 = Fault log triggered when MON1 is above its overvoltage threshold
		[5]	1 = Fault log triggered when MON2 is above its overvoltage threshold
		[6]	1 = Fault log triggered when MON3 is above its overvoltage threshold
		[7]	1 = Fault log triggered when MON4 is above its overvoltage threshold
70h	270h	[0]	1 = Fault log triggered when MON5 is above its overvoltage threshold
		[1]	1 = Fault log triggered when MON6 is above its overvoltage threshold
		[2]	1 = Fault log triggered when MON7 is above its overvoltage threshold
		[3]	1 = Fault log triggered when MON8 is above its overvoltage threshold
		[4]	1 = Fault log triggered when MON9 is above its overvoltage threshold
		[5]	1 = Fault log triggered when MON10 is above its overvoltage threshold
		[6]	1 = Fault log triggered when MON11 is above its overvoltage threshold
		[7]	1 = Fault log triggered when MON12 is above its overvoltage threshold
71h	271h	[0]	1 = Fault log triggered when MON1 is above/below the early threshold warning
		[1]	1 = Fault log triggered when MON2 is above/below the early threshold warning
		[2]	1 = Fault log triggered when MON3 is above/below the early threshold warning
		[3]	1 = Fault log triggered when MON4 is above/below the early threshold warning
		[4]	1 = Fault log triggered when MON5 is above/below the early threshold warning
		[5]	1 = Fault log triggered when MON6 is above/below the early threshold warning
		[6]	1 = Fault log triggered when MON7 is above/below the early threshold warning
		[7]	1 = Fault log triggered when MON8 is above/below the early threshold warning

12-Channel/8-Channel, Flash-Configurable System Managers with Nonvolatile Fault Registers

Table 14. Critical Fault Configuration (continued)

REGISTER ADDRESS	FLASH ADDRESS	BIT RANGE	DESCRIPTION
72h	272h	[0]	1 = Fault log triggered when MON9 is above/below the early threshold warning
		[1]	1 = Fault log triggered when MON10 is above/below the early threshold warning
		[2]	1 = Fault log triggered when MON11 is above/below the early threshold warning
		[3]	1 = Fault log triggered when MON12 is above/below the early threshold warning
		[4]	1 = Fault log triggered when overcurrent early threshold is exceeded
		[5]	Reserved, must be set to '1'
		[7:6]	Reserved

If a GPIO_ is configured as an open-drain $\overline{\text{EXTFAULT}}$ input/output, and $\overline{\text{EXTFAULT}}$ is pulled low by an external circuit, bit r1Ch[5] is set.

The SMB Alert bit is set if the MAX16070/MAX16071 have asserted the SMBus Alert output. Clear by writing a '1'. See *SMBALERT* section for more details.

Critical Faults

During normal operation, a fault condition can be configured to store fault information in the flash memory by setting the appropriate critical fault enable bits. Set the appropriate critical fault enable bits in registers r6Eh to r72h (see Table 14) for a fault condition to trigger a critical fault.

Logged fault information is stored in flash registers r200h to r20Fh (see Table 15). After fault information is logged, the flash is locked and must be unlocked to enable a new fault log to be stored. Write a '0' to r8Ch[1] to unlock the fault flash. Fault information can be configured to store ADC conversion results and/or fault flags in registers. Select the critical fault configuration in r6Dh[1:0]. Set r6Dh[1:0] to '11' to turn off the fault logger. All stored ADC results are 8 bits wide.

Table 15. Nonvolatile Fault Log Registers

FLASH ADDRESS	BIT RANGE	DESCRIPTION
200h	—	Reserved
201h	[0]	Fault log triggered on MON1
	[1]	Fault log triggered on MON2
	[2]	Fault log triggered on MON3
	[3]	Fault log triggered on MON4
	[4]	Fault log triggered on MON5
	[5]	Fault log triggered on MON6
	[6]	Fault log triggered on MON7
	[7]	Fault log triggered on MON8
202h	[0]	Fault log triggered on MON9
	[1]	Fault log triggered on MON10
	[2]	Fault log triggered on MON11
	[3]	Fault log triggered on MON12
	[4]	Fault log triggered on overcurrent
	[5]	Fault log triggered on $\overline{\text{EXTFAULT}}$
	[7:6]	Not used

12-Channel/8-Channel, Flash-Configurable System Managers with Nonvolatile Fault Registers

Table 15. Nonvolatile Fault Log Registers (continued)

FLASH ADDRESS	BIT RANGE	DESCRIPTION
203h	[7:0]	MON1 ADC output
204h	[7:0]	MON2 ADC output
205h	[7:0]	MON3 ADC output
206h	[7:0]	MON4 ADC output
207h	[7:0]	MON5 ADC output
208h	[7:0]	MON6 ADC output
209h	[7:0]	MON7 ADC output
20Ah	[7:0]	MON8 ADC output
20Bh	[7:0]	MON9 ADC output
20Ch	[7:0]	MON10 ADC output
20Dh	[7:0]	MON11 ADC output
20Eh	[7:0]	MON12 ADC output
20Fh	[7:0]	Current-sense ADC output

Reset Output

The reset output, RESET, indicates the status of the monitored inputs.

During normal monitoring, RESET can be configured to assert when any combination of MON_ inputs violates configurable combinations of thresholds: undervoltage, overvoltage, or early warning. Select the combination of thresholds using r3Bh[1:0], and select the combination of MON_ inputs using rCh[7:1] and r3Dh[4:0]. Note that MON_ inputs configured as critical faults will always cause RESET to assert regardless of these configuration bits.

RESET can be configured as push-pull or open drain using r3Bh[3], and active-high or active-low using r3Bh[2]. Select the reset timeout by loading a value from Table 16 into r3Bh[7:4]. RESET can be forced to assert by writing a '1' into r3Ch[0]. RESET remains asserted for the reset timeout period after a '0' is written into r3Ch[0]. See Table 16. The current state of RESET can be checked by reading r20h[0].

Watchdog Timer

The watchdog timer operates together with or independently of the MAX16070/MAX16071. When operating in dependent mode, the watchdog is not activated until EN goes high and RESET is deasserted. When operating in

independent mode, the watchdog timer activates immediately after VCC exceeds the UVLO threshold and the boot phase is complete. Set r73h[4] to '0' to configure the watchdog in dependent mode. Set r73h[4] to '1' to configure the watchdog in independent mode. See Table 17 for more information on configuring the watchdog timer in dependent or independent mode.

Dependent Watchdog Timer Operation

Use the watchdog timer to monitor μ P activity in two modes. Flexible timeout architecture provides an adjustable watchdog startup delay of up to 300s, allowing complicated systems to complete lengthy boot-up routines. An adjustable watchdog timeout allows the supervisor to provide quick alerts when processor activity fails. After each reset event (VCC drops below UVLO then returns above UVLO, software reboot, manual reset (MR), EN input going low then high, or watchdog reset), the watchdog startup delay provides an extended time for the system to power up and fully initialize all μ P and system components before assuming responsibility for routine watchdog updates. Set r76h[6:4] to a value other than '000' to enable the watchdog startup delay. Set r76h[6:4] to '000' to disable the watchdog startup delay.

12-Channel/8-Channel, Flash-Configurable System Managers with Nonvolatile Fault Registers

Table 16. Reset Output Configuration

REGISTER ADDRESS	FLASH ADDRESS	BIT RANGE	DESCRIPTION
3Bh	23Bh	[1:0]	Reset output depends on: 00 = Undervoltage threshold violations 01 = Early warning threshold violations 10 = Overvoltage threshold violations 11 = Undervoltage or overvoltage threshold violations
		[2]	0 = Active-low 1 = Active-high
		[3]	0 = Push-pull 1 = Open drain
		[7:4]	Reset timeout period 0000 = 25µs 0001 = 1.5ms 0010 = 2.5ms 0011 = 4ms 0100 = 6ms 0101 = 10ms 0110 = 15ms 0111 = 25ms 1000 = 40ms 1001 = 60ms 1010 = 100ms 1011 = 150ms 1100 = 250ms 1101 = 400ms 1110 = 600ms 1111 = 1s
3Ch	23Ch	[0]	Reset soft trigger 0 = Normal RESET behavior 1 = Force RESET to assert
		[1]	1 = RESET depends on MON1
		[2]	1 = RESET depends on MON2
		[3]	1 = RESET depends on MON3
		[4]	1 = RESET depends on MON4
		[5]	1 = RESET depends on MON5
		[6]	1 = RESET depends on MON6
		[7]	1 = RESET depends on MON7
3Dh	23Dh	[0]	1 = RESET depends on MON8
		[1]	1 = RESET depends on MON9
		[2]	1 = RESET depends on MON10
		[3]	1 = RESET depends on MON11
		[4]	1 = RESET depends on MON12
		[7:5]	Reserved

www.DataSheet4U.com

12-Channel/8-Channel, Flash-Configurable System Managers with Nonvolatile Fault Registers

MAX16070/MAX16071 Table 17. Watchdog Configuration

REGISTER ADDRESS	FLASH ADDRESS	BIT RANGE	DESCRIPTION
73h	273h	[4]	1 = Independent mode 0 = Dependent mode
76h	276h	[7]	1 = Watchdog affects RESET output 0 = Watchdog does not affect RESET output
		[6:4]	Watchdog startup delay 000 = No initial timeout 001 = 30s 010 = 40s 011 = 80s 100 = 120s 101 = 160s 110 = 220s 111 = 300s
		[3:0]	Watchdog timeout 0000 = Watchdog disabled 0001 = 1ms 0010 = 2ms 0011 = 4ms 0100 = 8ms 0101 = 14ms 0110 = 27ms 0111 = 50ms 1000 = 100ms 1001 = 200ms 1010 = 400ms 1011 = 750ms 1100 = 1.4s 1101 = 2.7s 1110 = 5s 1111 = 10s

The normal watchdog timeout period, t_{WDI} , begins after the first transition on WDI before the conclusion of the long startup watchdog period, $t_{WDI_STARTUP}$ (Figure 5). During the normal operating mode, \overline{WDO} asserts if the μP does not toggle WDI with a valid transition (high-to-low or low-to-high) within the standard timeout period, t_{WDI} . \overline{WDO} remains asserted until WDI is toggled or RESET is asserted (Figure 6).

While EN is low, the watchdog timer is in reset. The watchdog timer does not begin counting until RESET is deasserted. The watchdog timer is reset and \overline{WDO} deasserts any time RESET is asserted (Figure 7). The watchdog timer will be held in reset while RESET is asserted.

The watchdog can be configured to control the RESET output as well as the \overline{WDO} output. RESET asserts for the reset timeout, t_{RP} , when the watchdog timer expires and the Watchdog Reset Output Enable bit (r76h[7]) is set to '1.' When RESET is asserted, the watchdog timer is cleared and \overline{WDO} is deasserted, therefore, \overline{WDO} pulses low for a short time (approximately 1 μ s) when the watchdog timer expires. RESET is not affected by the watchdog timer when the Watchdog Reset Output Enable bit (r76h[7]) is set to '0.' If a RESET is asserted by the watchdog timeout, the WDRESET bit is set to '1'. A connected processor can check this bit to see the reset was due to a watchdog timeout. See Table 17 for more information on configuring watchdog functionality.

12-Channel/8-Channel, Flash-Configurable System Managers with Nonvolatile Fault Registers

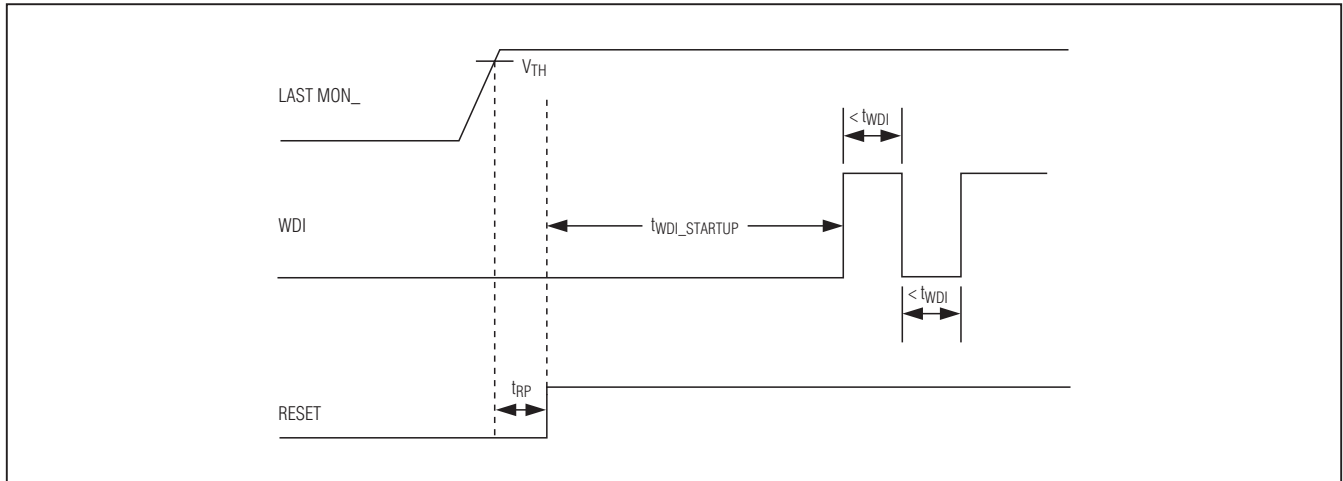

Figure 5. Normal Watchdog Startup Sequence

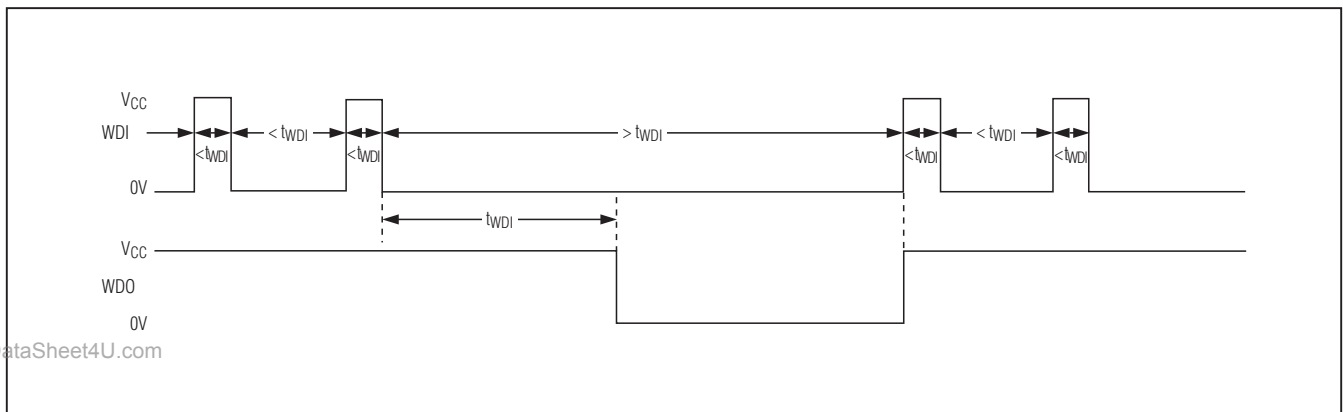

Figure 6. Watchdog Timer Operation

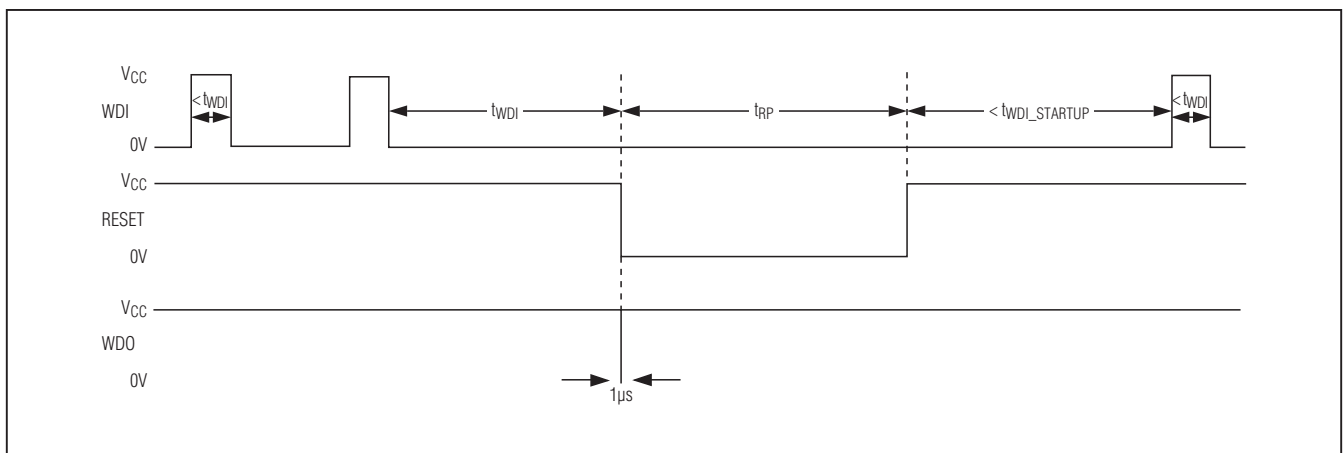

Figure 7. Watchdog Startup Sequence with Watchdog Reset Enable Bit Set to '1'

12-Channel/8-Channel, Flash-Configurable System Managers with Nonvolatile Fault Registers

MAX16070/MAX16071

Independent Watchdog Timer Operation

When r73h[3] is '1' the watchdog timer operates in the independent mode. In the independent mode, the watchdog timer operates as if it were a separate device. The watchdog timer is activated immediately upon V_{CC} exceeding UVLO and once the boot-up sequence is finished. When RESET is asserted, the watchdog timer and \overline{WDO} are not affected.

There will be a startup delay if r76h[6:4] is set to a value different than '000.' If r76h[6:4] is set to '000,' there will not be a startup delay. See Table 17 for delay times.

In independent mode, if the Watchdog Reset Output Enable bit r76h[7] is set to '1,' when the watchdog timer expires, \overline{WDO} asserts then RESET asserts. \overline{WDO} will then deassert. \overline{WDO} will be low for approximately 1 μ s. If the Watchdog Reset Output Enable bit (r76h[7]) is set to '0,' when the WDT expires, \overline{WDO} asserts but RESET is not affected.

User-Defined Register

Register r8Ah provides storage space for a user-defined configuration or firmware version number. Note that this register controls the contents of the JTAG USERCODE register bits 7:0. The user-defined register is stored at r28Ah in the flash memory.

Memory Lock Bits

Register r8Ch contains the lock bits for the configuration registers, configuration flash, user flash, and fault register lock. See Table 18 for details.

www.DataSheet4U.com

SMBus-Compatible Interface

The MAX16070/MAX16071 feature an SMBus-compatible, 2-wire serial interface consisting of a serial-data line (SDA) and a serial-clock line (SCL). SDA and SCL facilitate bidirectional communication between the MAX16070/MAX16071 and the master device at clock rates up to 400kHz. Figure 1 shows the 2-wire interface timing diagram. The MAX16070/MAX16071 are transmit/receive slave-only devices, relying upon a master device to generate a clock signal. The master device (typically a microcontroller) initiates a data transfer on the bus and generates SCL to permit that transfer.

A master device communicates to the MAX16070/MAX16071 by transmitting the proper address followed by a command and/or data words. The slave address input, A0, is capable of detecting four different states, allowing multiple identical devices to share the same serial bus. The slave address is described further in the *Slave Address* section. Each transmit sequence is framed by a START (S) or REPEATED START (SR) condition and a STOP (P) condition. Each word transmitted over the bus is 8 bits long and is always followed by an acknowledge pulse. SCL is a logic input, while SDA is an open-drain input/output. SCL and SDA both require external pullup resistors to generate the logic-high voltage. Use 4.7k Ω for most applications.

Table 18. Memory Lock Bits

REGISTER ADDRESS	FLASH ADDRESS	BIT RANGE	DESCRIPTION
8Ch	28Ch	0	Configuration register lock 1 = Locked 0 = Unlocked
		1	Flash fault register lock 1 = Locked 0 = Unlocked
		2	Flash configuration lock 1 = Locked 0 = Unlocked
		3	User flash lock 1 = Locked 0 = Unlocked

12-Channel/8-Channel, Flash-Configurable System Managers with Nonvolatile Fault Registers

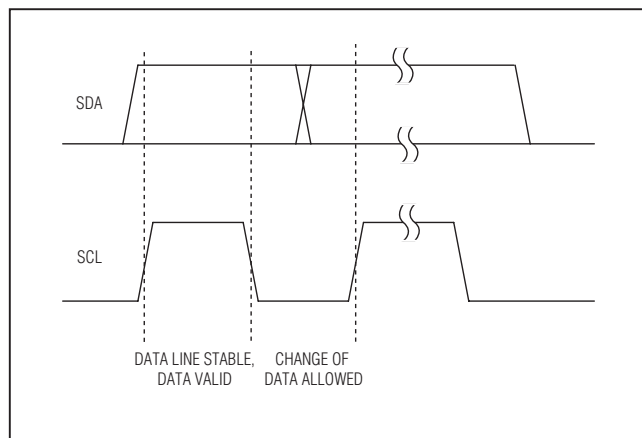

Figure 8. Bit Transfer

Bit Transfer

Each clock pulse transfers one data bit. The data on SDA must remain stable while SCL is high (Figure 8); otherwise the MAX16070/MAX16071 register a START or STOP condition (Figure 9) from the master. SDA and SCL idle high when the bus is not busy.

START and STOP Conditions

Both SCL and SDA idle high when the bus is not busy. A master device signals the beginning of a transmission with a START condition by transitioning SDA from high to low while SCL is high. The master device issues a STOP condition by transitioning SDA from low to high while SCL is high. A STOP condition frees the bus for another transmission. The bus remains active if a REPEATED START condition is generated, such as in the block read protocol (see Figure 1).

Early STOP Conditions

The MAX16070/MAX16071 recognize a STOP condition at any point during transmission except if a STOP condition occurs in the same high pulse as a START condition. This condition is not a legal SMBus format; at least one clock pulse must separate any START and STOP condition.

REPEATED START Conditions

A REPEATED START can be sent instead of a STOP condition to maintain control of the bus during a read operation. The START and REPEATED START conditions are functionally identical.

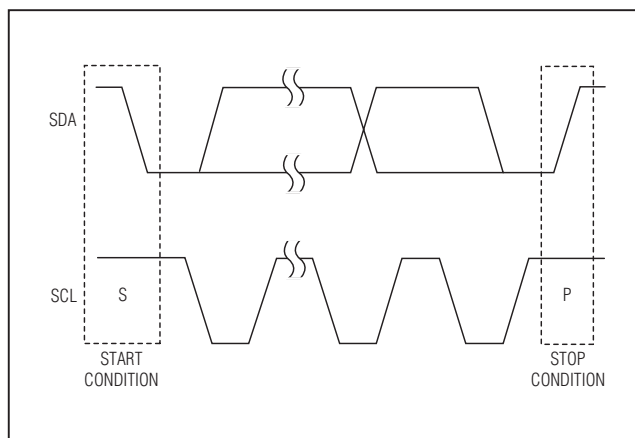

Figure 9. START and STOP Conditions

Acknowledge

The acknowledge bit (ACK) is the 9th bit attached to any 8-bit data word. The receiving device always generates an ACK. The MAX16070/MAX16071 generate an ACK when receiving an address or data by pulling SDA low during the 9th clock period (Figure 11). When transmitting data, such as when the master device reads data back from the MAX16070/MAX16071, the device waits for the master device to generate an ACK. Monitoring ACK allows for detection of unsuccessful data transfers. An unsuccessful data transfer occurs if the receiving device is busy or if a system fault has occurred. In the event of an unsuccessful data transfer, the bus master can reattempt communication at a later time. The MAX16070/MAX16071 generate a NACK after the command byte received during a software reboot, while writing to the flash, or when receiving an illegal memory address.

Slave Address

Use the slave address input, A0, to allow multiple identical devices to share the same serial bus. Connect A0 to GND, DBP (or an external supply voltage greater than 2V), SCL, or SDA to set the device address on the bus. See Table 20 for a listing of all possible 7-bit addresses.

The slave address can also be set to a custom value by loading the address into register r8Bh[6:0]. See Table 19. If r8Bh[6:0] is loaded with 00h, the address is set by input A0. Do not set the address to 09h or 7Fh to avoid address conflicts. The slave address setting takes effect immediately after writing to the register.

12-Channel/8-Channel, Flash-Configurable System Managers with Nonvolatile Fault Registers

MAX16070/MAX16071

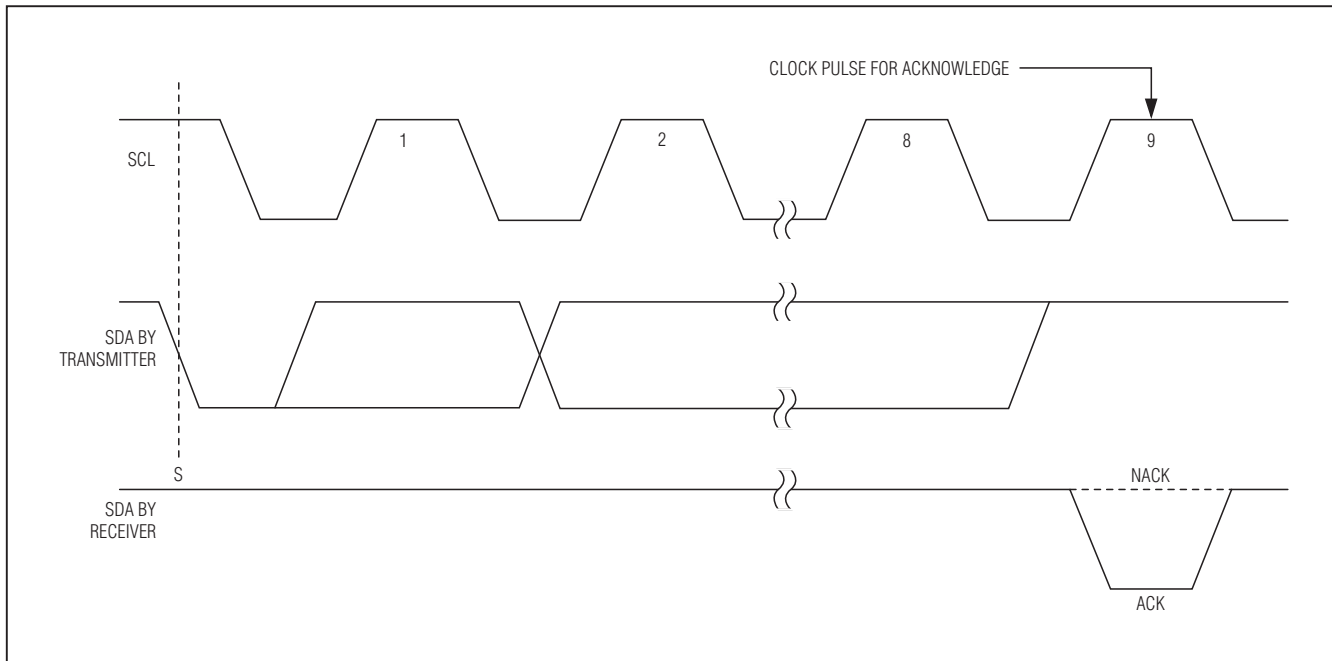

Figure 10. Acknowledge

Table 19. SMBus Settings Register

REGISTER ADDRESS	FLASH ADDRESS	BIT RANGE	DESCRIPTION
8Bh	28Bh	[6:0]	I ² C Slave Address Register. Set to 00h to use A0 pin address setting.
		[7]	1 = Enable PEC (packet error check).

Table 20. Setting the SMBus Slave Address

SLAVE ADDRESSES	
A0	SLAVE ADDRESS
0	1010 000R
1	1010 001R
SCL	1010 010R
SDA	1010 011R

R = Read/Write select bit

12-Channel/8-Channel, Flash-Configurable System Managers with Nonvolatile Fault Registers

Packet Error Checking (PEC)

The MAX16070/MAX16071 feature a PEC mode that is useful for improving the reliability of the communication bus by detecting bit errors. By enabling PEC, an extra CRC-8 error check byte is added in the data string during each read and/or write sequence. Enable PEC by writing a '1' to r8Bh[7].

The CRC-8 byte is calculated using the polynomial $C = X^8 + X^2 + X + 1$

The PEC calculation includes all bytes in the transmission, including address, command, and data. The PEC calculation does not include ACK, NACK, START, STOP, or REPEATED START.

Command Codes

The MAX16070/MAX16071 use eight command codes for block read, block write, and other commands. See Table 21 for a list of command codes.

To initiate a software reboot, send A7h using the send byte format. A software-initiated reboot is functionally the same as a hardware-initiated power-on reset. During boot-up, flash configuration data in the range of 230h to 28Ch is copied to r30h to r8Ch registers in the default page.

Send command code A8h to trigger a fault store to flash. Configure the Critical Fault Log Control register (6Dh) to store ADC conversion results and/or fault flags.

While in the flash page, send command code A9h to access the flash page (addresses from 200h to 28Fh). Once command code A9h has been sent, all addresses are recognized as flash addresses only. Send command code AAh to return to the default page (addresses from 000h to 0FFh). Send command code ABh to access the user flash-page (addresses from 300h to 3A4h and 3ADh–3ffh), and send command code ACh to return to the flash page.

Table 21. Command Codes

COMMAND CODE	ACTION
A5h	Block write
A6h	Block read
A7h	Reboot flash in register file
A8h	Trigger emergency save to flash
A9h	Flash page access ON
AAh	Flash page access OFF
ABh	User flash access ON (must be in flash page already)
ACh	User flash access OFF (return to flash page)

Restrictions When Writing to Flash

Flash must be written to 8 bytes at a time. The initial address must be aligned to 8-byte boundaries—the three LSBs of the initial address must be '000.' Write the 8 bytes using a single block-write command or using 8 successive Write Byte commands.

Send Byte

The send byte protocol allows the master device to send one byte of data to the slave device (see Figure 11). The send byte presets a register pointer address for a subsequent read or write. The slave sends a NACK instead of an ACK if the master tries to send a memory address or command code that is not allowed. If the master sends A5h or A6h, the data is ACK, because this could be the start of the write block or read block. If the master sends a STOP condition before the slave asserts an ACK, the internal address pointer does not change. If the master sends A7h, this signifies a software reboot. The send byte procedure is the following:

- 1) The master sends a START condition.
- 2) The master sends the 7-bit slave address and a write bit (low).
- 3) The addressed slave asserts an ACK on SDA.
- 4) The master sends an 8-bit memory address or command code.
- 5) The addressed slave asserts an ACK (or NACK) on SDA.
- 6) The master sends a STOP condition.

12-Channel/8-Channel, Flash-Configurable System Managers with Nonvolatile Fault Registers

MAX16070/MAX16071

Send Byte Format

S	ADDRESS	R/W	ACK	COMMAND	ACK	P
↓	7 bits	0	0	8 bits	0	↑

Slave Address: Address of the slave on the serial interface bus.

Data Byte: Presets the internal address pointer or represents a command.

Receive Byte Format

S	ADDRESS	R/W	ACK	DATA	NACK	P
↓	7 bits	1	0	8 bits	1	↑

Slave Address: Address of the slave on the serial interface bus.

Data Byte: Data is read from the location pointed to by the internal address pointer.

Write Byte Format

S	ADDRESS	R/W	ACK	COMMAND	ACK	DATA	ACK	P
↓	7 bits	0	0	8 bits	0	8 bits	0	↑

Slave Address: Address of the slave on the serial interface bus.

Command Byte: Sets the internal address pointer.

Data Byte: Data is written to the locations set by the internal address pointer.

SMBALERT#

S	ADDRESS	R/W	ACK	DATA	NACK	P
↓	0001100	D.C.	0	8 bits	1	↑

Alert Response Address: Only the device that interrupted the master responds to this address.

Slave Address: Slave places its own address on the serial bus.

Read Byte Format

S	SLAVE ADDRESS	R/W	ACK	COMMAND	ACK	SR	SLAVE ADDRESS	R/W	ACK	DATA BYTE	NACK	P
↓	7 bits	0	0	8 bits	0	↓	7 bits	1	0	8 bits	1	↑

Slave Address: Address of the slave on the serial interface bus.

Command Byte: Sets the internal address pointer.

Data Byte: Data is written to the locations set by the internal address pointer.

Block Write Format

S	ADDRESS	R/W	ACK	COMMAND	ACK	BYTE COUNT = N	ACK	DATA BYTE 1	ACK	DATA BYTE ...	ACK	DATA BYTE N	ACK	P
↓	7 bits	0	0	8 bits	0	8 bits	0	8 bits	0	8 bits	0	8 bits	0	↑

Slave Address: Address of the slave on the serial interface bus.

Command Byte: FAh

Data Byte: Data is written to the locations set by the internal address pointer.

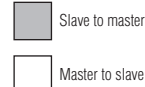

Block Read Format

S	ADDRESS	R/W	ACK	COMMAND	ACK	SR	ADDRESS	R/W	ACK	BYTE COUNT = N	ACK	DATA BYTE N	ACK	DATA BYTE ...	ACK	DATA BYTE N	NACK	P	
↓	7 bits	0	0	8 bits	0	↓	7 bits	1	0	8 bits	0	8 bits	0	8 bits	0	8 bits	0	1	↑

Slave Address: Address of the slave on the serial interface bus.

Command Byte: FBh

Slave Address: Address of the slave on the serial interface bus.

Data Byte: Data is read from the locations set by the internal address pointer.

Write Byte Format with PEC

S	ADDRESS	R/W	A	COMMAND	A	DATA	A	PEC	A	P
↓	7 BITS	0	0	8 BITS	0	8 BITS	0	8 BITS	0	↑

Read Byte Format with PEC

S	ADDRESS	R/W	A	COMMAND	A	SR	ADDRESS	R/W	A	DATA	A	PEC	A	P
↓	7 BITS	0	0	8 BITS	0	↓	7 BITS	1	0	8 BITS	0	8 BITS	0	↑

Block Write with PEC

S	ADDRESS	R/W	A	COMMAND	A	BYTE COUNT N	A	DATA BYTE 1	A	DATA BYTE ...	A	DATA N	A	PEC	A	P
↓	7 BITS	0	0	8 BITS	0	8 BITS	0	8 BITS	0	8 BITS	0	8 BITS	0	8 BITS	0	↑

Block Read with PEC

S	ADDRESS	R/W	A	COMMAND	A	SR	ADDRESS	R/W	A	BYTE COUNT N	A	DATA BYTE 1	A	DATA BYTE ...	A	DATA N	A	PEC	N	P
↓	7 BITS	0	0	8 BITS	0	↓	7 BITS	1	0	8 BITS	0	8 BITS	0	8 BITS	0	8 BITS	0	8 BITS	P	↑

S = START Condition
P = STOP Condition
Sr = Repeated START Condition
D.C. = Don't Care

ACK = Acknowledge, SDA pulled low during rising edge of SCL.
NACK = Not acknowledge, SDA left high during rising edge of SCL.
All data is clocked in/out of the device on rising edges of SCL.

↓ = SDA transitions from high to low during period of SCL.
↑ = SDA transitions from low to high during period of SCL.

Figure 11. SMBus Protocols

12-Channel/8-Channel, Flash-Configurable System Managers with Nonvolatile Fault Registers

Receive Byte

The receive byte protocol allows the master device to read the register content of the MAX16070/MAX16071 (see Figure 11). The flash or register address must be preset with a send byte or write word protocol first. Once the read is complete, the internal pointer increases by one. Repeating the receive byte protocol reads the contents of the next address. The receive byte procedure follows:

- 1) The master sends a START condition.
- 2) The master sends the 7-bit slave address and a read bit (high).
- 3) The addressed slave asserts an ACK on SDA.
- 4) The slave sends 8 data bits.
- 5) The master asserts a NACK on SDA.
- 6) The master generates a STOP condition.

Write Byte

The write byte protocol (see Figure 11) allows the master device to write a single byte in the default page, extended page, or flash page, depending on which page is currently selected. The write byte procedure is the following:

- 1) The master sends a START condition.
- 2) The master sends the 7-bit slave address and a write bit (low).
- 3) The addressed slave asserts an ACK on SDA.
- 4) The master sends an 8-bit memory address.
- 5) The addressed slave asserts an ACK on SDA.
- 6) The master sends an 8-bit data byte.
- 7) The addressed slave asserts an ACK on SDA.
- 8) The master sends a STOP condition.

To write a single byte, only the 8-bit memory address and a single 8-bit data byte are sent. The data byte is written to the addressed location if the memory address is valid. The slave asserts a NACK at step 5 if the memory address is not valid.

When PEC is enabled, the Write Byte protocol becomes:

- 1) The master sends a START condition.
- 2) The master sends the 7-bit slave ID plus a write bit (low).
- 3) The addressed slave asserts an ACK on the data line.
- 4) The master sends an 8-bit command code.
- 5) The active slave asserts an ACK on the data line.
- 6) The master sends an 8-bit data byte.

- 7) The slave asserts an ACK on the data line.
- 8) The master sends an 8-bit PEC byte.
- 9) The slave asserts an ACK on the data line (if PEC is good, otherwise NACK).
- 10) The master generates a STOP condition.

Read Byte

The read byte protocol (see Figure 11) allows the master device to read a single byte located in the default page, extended page, or flash page depending on which page is currently selected. The read byte procedure is the following:

- 1) The master sends a START condition.
- 2) The master sends the 7-bit slave address and a write bit (low).
- 3) The addressed slave asserts an ACK on SDA.
- 4) The master sends an 8-bit memory address.
- 5) The addressed slave asserts an ACK on SDA.
- 6) The master sends a REPEATED START condition.
- 7) The master sends the 7-bit slave address and a read bit (high).
- 8) The addressed slave asserts an ACK on SDA.
- 9) The slave sends an 8-bit data byte.
- 10) The master asserts a NACK on SDA.
- 11) The master sends a STOP condition.

If the memory address is not valid, it is NACKed by the slave at step 5 and the address pointer is not modified.

When PEC is enabled, the Read Byte protocol becomes:

- 1) The master sends a START condition.
- 2) The master sends the 7-bit slave ID plus a write bit (low).
- 3) The addressed slave asserts an ACK on the data line.
- 4) The master sends 8 data bits.
- 5) The active slave asserts an ACK on the data line.
- 6) The master sends a REPEATED START condition.
- 7) The master sends the 7-bit slave ID plus a read bit (high).
- 8) The addressed slave asserts an ACK on the data line.
- 9) The slave sends 8 data bits.
- 10) The master asserts an ACK on the data line.
- 11) The slave sends an 8-bit PEC byte.
- 12) The master asserts a NACK on the data line.
- 13) The master generates a STOP condition.

12-Channel/8-Channel, Flash-Configurable System Managers with Nonvolatile Fault Registers

MAX16070/MAX16071

Block Write

The block write protocol (see Figure 11) allows the master device to write a block of data (1 byte to 16 bytes) to memory. Preload the destination address by a previous send byte command; otherwise the block write command begins to write at the current address pointer. After the last byte is written, the address pointer remains preset to the next valid address. If the number of bytes to be written causes the address pointer to exceed 8Fh for configuration registers or configuration flash or FFh for user flash, the address pointer stays at 8Fh or FFh, respectively, overwriting this memory address with the remaining bytes of data. The slave generates a NACK at step 5 if the command code is invalid or if the device is busy, and the address pointer is not altered.

The block write procedure is the following:

- 1) The master sends a START condition.
- 2) The master sends the 7-bit slave address and a write bit (low).
- 3) The addressed slave asserts an ACK on SDA.
- 4) The master sends the 8-bit command code for block write (94h).
- 5) The addressed slave asserts an ACK on SDA.
- 6) The master sends the 8-bit byte count (1 byte to 16 bytes), n.
- 7) The addressed slave asserts an ACK on SDA.
- 8) The master sends 8 bits of data.
- 9) The addressed slave asserts an ACK on SDA.
- 10) Repeat steps 8 and 9 n - 1 times.
- 11) The master sends a STOP condition.

When PEC is enabled, the Block Write protocol becomes:

- 1) The master sends a START condition.
- 2) The master sends the 7-bit slave ID plus a write bit (low).
- 3) The addressed slave asserts an ACK on the data line.
- 4) The master sends 8 bits of the block write command code.
- 5) The slave asserts an ACK on the data line.
- 6) The master sends an 8-bit byte count (min 1, max 16), n.
- 7) The slave asserts an ACK on the data line.
- 8) The master sends 8 bits of data.

- 9) The slave asserts an ACK on the data line.
- 10) Repeat 8 and 9 n - 1 times.
- 11) The master sends an 8-bit PEC byte.
- 12) The slave asserts an ACK on the data line (if PEC is good, otherwise NACK).
- 13) The master generates a STOP condition.

Block Read

The block read protocol (see Figure 11) allows the master device to read a block of up to 16 bytes from memory. Read fewer than 16 bytes of data by issuing an early STOP condition from the master, or by generating a NACK with the master. The destination address should be preloaded by a previous send byte command; otherwise the block read command begins to read at the current address pointer. If the number of bytes to be read causes the address pointer to exceed 8Fh for the configuration register or configuration flash or FFh in user flash, the address pointer stays at 8Fh or FFh, respectively. The block read procedure is the following:

- 1) The master sends a START condition.
- 2) The master sends the 7-bit slave address and a write bit (low).
- 3) The addressed slave asserts an ACK on SDA.
- 4) The master sends 8 bits of the block read command (95h).
- 5) The slave asserts an ACK on SDA, unless busy.
- 6) The master generates a REPEATED START condition.
- 7) The master sends the 7-bit slave address and a read bit (high).
- 8) The slave asserts an ACK on SDA.
- 9) The slave sends the 8-bit byte count (16).
- 10) The master asserts an ACK on SDA.
- 11) The slave sends 8 bits of data.
- 12) The master asserts an ACK on SDA.
- 13) Repeat steps 11 and 12 up to fifteen times.
- 14) The master asserts a NACK on SDA.
- 15) The master sends a STOP condition.

When PEC is enabled, the Block Read protocol becomes:

- 1) The master sends a START condition.
- 2) The master sends the 7-bit slave ID plus a write bit (low).

12-Channel/8-Channel, Flash-Configurable System Managers with Nonvolatile Fault Registers

Table 22. SMBus Alert Configuration

REGISTER ADDRESS	FLASH ADDRESS	BIT RANGE	DESCRIPTION
35h	235h	[1:0]	SMBus Alert Configuration 00 = Disabled 01 = Fault1 is SMBus $\overline{\text{ALERT}}$ 10 = Fault2 is SMBus $\overline{\text{ALERT}}$ 11 = $\overline{\text{Any_Fault}}$ is SMBus $\overline{\text{ALERT}}$

- 3) The addressed slave asserts an ACK on the data line.
- 4) The master sends 8 bits of the block read command code.
- 5) The slave asserts an ACK on the data line unless busy.
- 6) The master sends a REPEATED START condition.
- 7) The master sends the 7-bit slave ID plus a read bit (high).
- 8) The slave asserts an ACK on the data line.
- 9) The slave sends an 8-bit byte count (16).
- 10) The master asserts an ACK on the data line.
- 11) The slave sends 8 bits of data.
- 12) The master asserts an ACK on the data line.
- 13) Repeat steps 11 and 12 up to 15 times.
- 14) The slave sends an 8-bit PEC byte.
- 15) The master asserts a NACK on the data line.
- 16) The master generates a STOP condition.

SMBALERT

The MAX16070/MAX16071 support the SMBus alert protocol. To enable the SMBus alert output, set r35h[1:0] according to Table 22, which configures a Fault1, Fault2, or $\overline{\text{Any_Fault}}$ output to act as the SMBus alert. This output is open-drain and uses the wired-OR configuration with other devices on the SMBus. During a fault, the MAX16070/MAX16071 assert $\overline{\text{ALERT}}$ low, signaling the master that an interrupt has occurred. The master responds by sending the ARA (Alert Response Address) protocol on the SMBus. This protocol is a read byte with 09h as the slave address. The slave acknowledges the ARA (09h) address and sends its own SMBus address to the master. The slave then deasserts $\overline{\text{ALERT}}$. The master can then query the slave and determine the cause of the fault. By checking r1C[6], the master can confirm that the MAX16070/MAX16071 triggered the SMBus alert. The master must send the ARA before clearing r1Ch[6]. Clear r1Ch[6] by writing a '1'.

JTAG Serial Interface

The MAX16070/MAX16071 feature a JTAG port that complies with a subset of the IEEE 1149.1 specification. Either the SMBus or the JTAG interface can be used to access internal memory; however, only one interface is allowed to run at a time. The MAX16070/MAX16071 do not support IEEE 1149.1 boundary-scan functionality. The MAX16070/MAX16071 contain extra JTAG instructions and registers not included in the JTAG specification that provide access to internal memory. The extra instructions include LOAD ADDRESS, WRITE, READ, REBOOT, SAVE.

12-Channel/8-Channel, Flash-Configurable System Managers with Nonvolatile Fault Registers

MAX16070/MAX16071

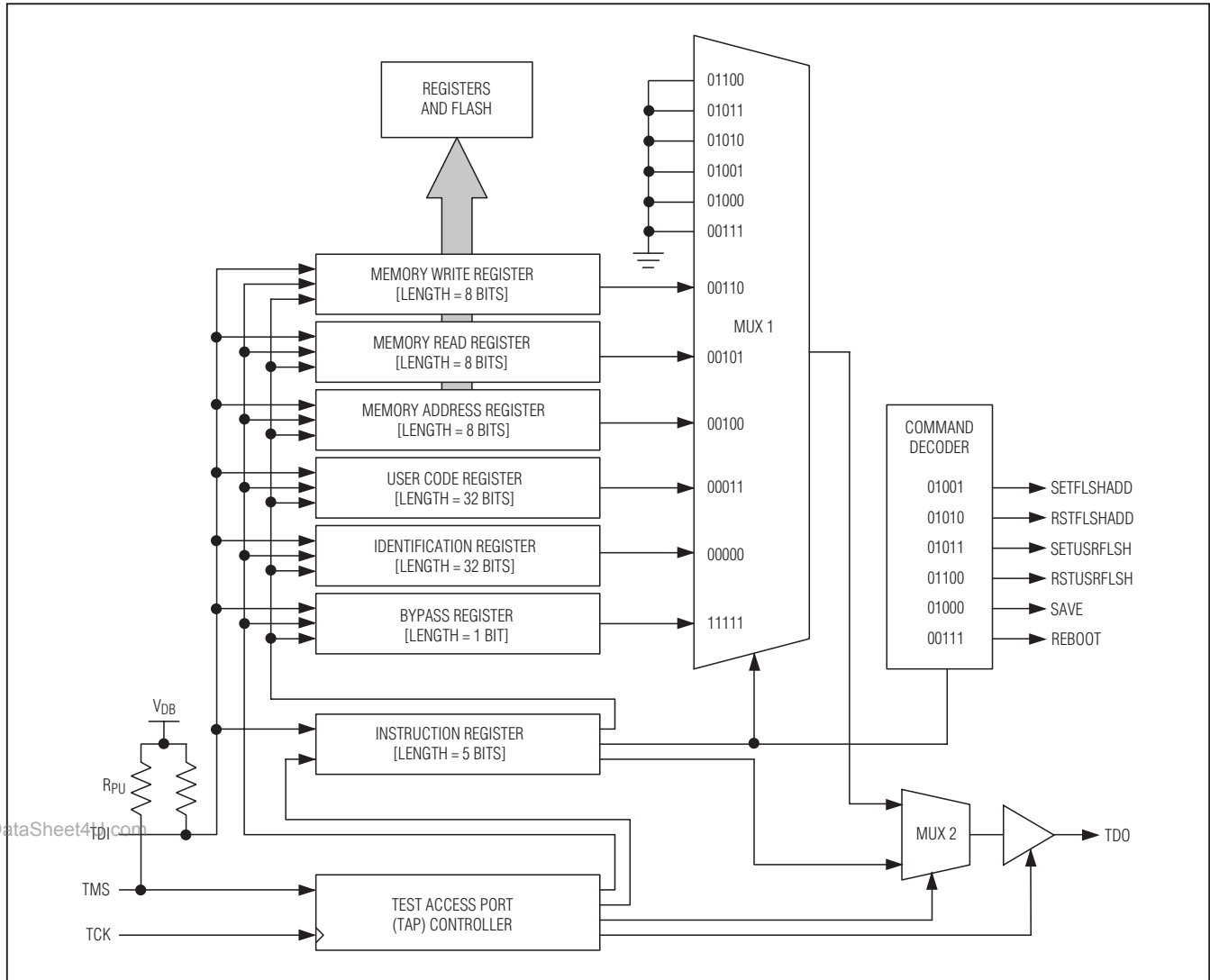

Figure 12. JTAG Block Diagram

Test Access Port (TAP) Controller State Machine

The TAP controller is a finite state machine that responds to the logic level at TMS on the rising edge of TCK. See Figure 13 for a diagram of the finite state machine. The possible states are described in the following:

Test-Logic-Reset: At power-up, the TAP controller is in the test-logic-reset state. The instruction register contains the IDCODE instruction. All system logic of the device operates normally. This state can be reached from any state by driving TMS high for five clock cycles.

Run-Test/Idle: The run-test/idle state is used between scan operations or during specific tests. The instruction register and test data registers remain idle.

Select-DR-Scan: All test data registers retain their previous state. With TMS low, a rising edge of TCK moves the controller into the capture-DR state and initiates a scan sequence. TMS high during a rising edge on TCK moves the controller to the select-IR-scan state.

Capture-DR: Data can be parallel-loaded into the test data registers selected by the current instruction. If the instruction does not call for a parallel load or the selected test data register does not allow parallel loads, the test

12-Channel/8-Channel, Flash-Configurable System Managers with Nonvolatile Fault Registers

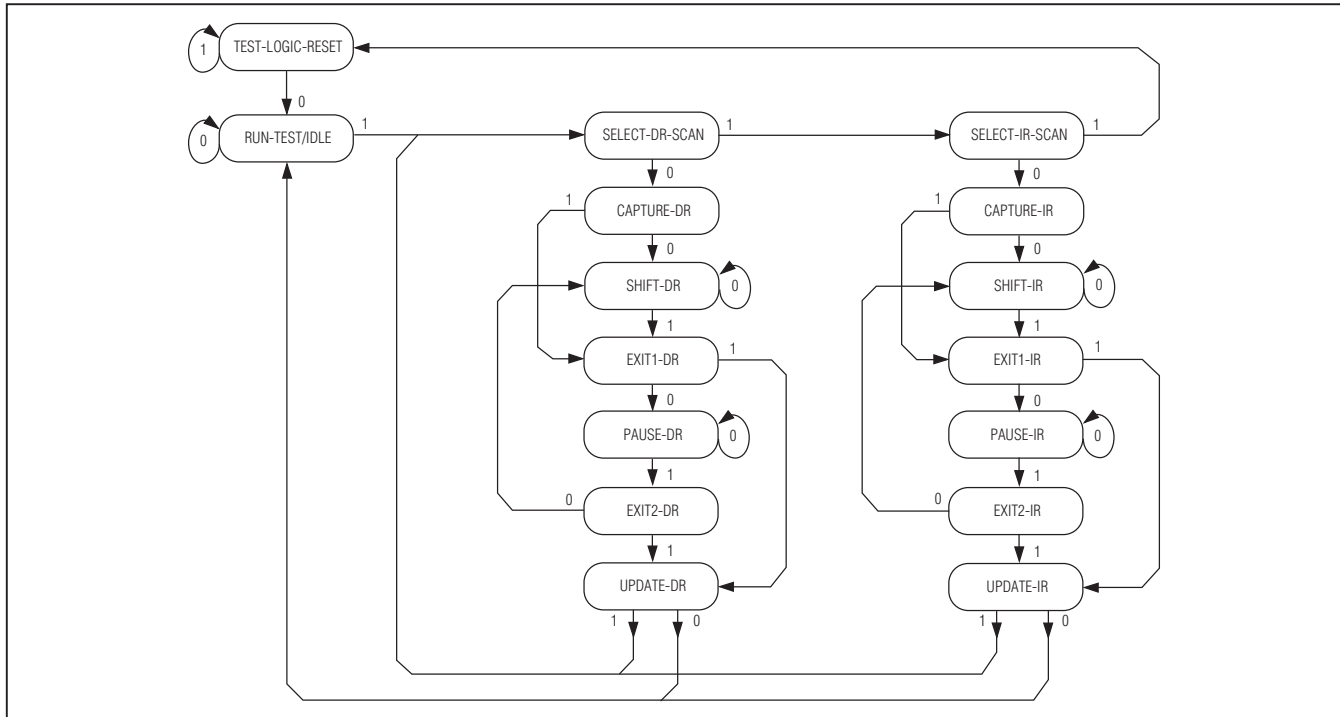

Figure 13. Tap Controller State Diagram

data register remains at its current value. On the rising edge of TCK, the controller goes to the shift-DR state if TMS is low or it goes to the exit1-DR state if TMS is high.

Shift-DR: The test data register selected by the current instruction connects between TDI and TDO and shifts data one stage toward its serial output on each rising edge of TCK while TMS is low. On the rising edge of TCK, the controller goes to the exit1-DR state if TMS is high.

Exit1-DR: While in this state, a rising edge on TCK puts the controller in the update-DR state. A rising edge on TCK with TMS low puts the controller in the pause-DR state.

Pause-DR: Shifting of the test data registers halts while in this state. All test data registers retain their previous state. The controller remains in this state while TMS is low. A rising edge on TCK with TMS high puts the controller in the exit2-DR state.

Exit2-DR: A rising edge on TCK with TMS high while in this state puts the controller in the update-DR state. A rising edge on TCK with TMS low enters the shift-DR state.

Update-DR: A falling edge on TCK while in the update-DR state latches the data from the shift register path of the test data registers into a set of output latches. This prevents changes at the parallel output because of changes in the shift register. On the rising edge of TCK,

the controller goes to the run-test/idle state if TMS is low or goes to the select-DR-scan state if TMS is high.

Select-IR-Scan: All test data registers retain the previous states. The instruction register remains unchanged during this state. With TMS low, a rising edge on TCK moves the controller into the capture-IR state. TMS high during a rising edge on TCK puts the controller back into the test-logic-reset state.

Capture-IR: Use the capture-IR state to load the shift register in the instruction register with a fixed value. This value is loaded on the rising edge of TCK. If TMS is high on the rising edge of TCK, the controller enters the exit1-IR state. If TMS is low on the rising edge of TCK, the controller enters the shift-IR state.

Shift-IR: In this state, the shift register in the instruction register connects between TDI and TDO and shifts data one stage for every rising edge of TCK toward the TDO serial output while TMS is low. The parallel outputs of the instruction register as well as all test data registers remain at the previous states. A rising edge on TCK with TMS high moves the controller to the exit1-IR state. A rising edge on TCK with TMS low keeps the controller in the shift-IR state while moving data one stage through the instruction shift register.

12-Channel/8-Channel, Flash-Configurable System Managers with Nonvolatile Fault Registers

MAX16070/MAX16071

Exit1-IR: A rising edge on TCK with TMS low puts the controller in the pause-IR state. If TMS is high on the rising edge of TCK, the controller enters the update-IR state.

Pause-IR: Shifting of the instruction shift register halts temporarily. With TMS high, a rising edge on TCK puts the controller in the exit2-IR state. The controller remains in the pause-IR state if TMS is low during a rising edge on TCK.

Exit2-IR: A rising edge on TCK with TMS high puts the controller in the update-IR state. The controller loops back to shift-IR if TMS is low during a rising edge of TCK in this state.

Update-IR: The instruction code that has been shifted into the instruction shift register latches to the parallel outputs of the instruction register on the falling edge of TCK as the controller enters this state. Once latched, this instruction becomes the current instruction. A rising edge on TCK with TMS low puts the controller in the run-test/idle state. With TMS high, the controller enters the select-DR-scan state.

Instruction Register

The instruction register contains a shift register as well as a latched 5-bit-wide parallel output. When the TAP controller enters the shift-IR state, the instruction shift

register connects between TDI and TDO. While in the shift-IR state, a rising edge on TCK with TMS low shifts the data one stage toward the serial output at TDO. A rising edge on TCK in the exit1-IR state or the exit2-IR state with TMS high moves the controller to the update-IR state. The falling edge of that same TCK latches the data in the instruction shift register to the instruction register parallel output. Table 23 shows the instructions supported by the MAX16070/MAX16071 and the respective operational binary codes.

BYPASS: When the BYPASS instruction is latched into the instruction register, TDI connects to TDO through the 1-bit bypass test data register. This allows data to pass from TDI to TDO without affecting the device's operation.

IDCODE: When the IDCODE instruction is latched into the parallel instruction register, the identification data register is selected. The device identification code is loaded into the identification data register on the rising edge of TCK following entry into the capture-DR state. Shift-DR can be used to shift the identification code out serially through TDO. During test-logic-reset, the IDCODE instruction is forced into the instruction register. The identification code always has a '1' in the LSB position. The next 11 bits identify the manufacturer's JEDEC number and number of continuation bytes followed by 16 bits for the device and 4 bits for the version. See Table 24.

Table 23. JTAG Instruction Set

INSTRUCTION	CODE	NOTES
BYPASS	0x1F	Mandatory instruction code
IDCODE	0x00	Load manufacturer ID code/part number
USERCODE	0x03	Load user code
LOAD ADDRESS	0x04	Load address register content
READ DATA	0x05	Read data pointed by current address
WRITE DATA	0x06	Write data pointed by current address
REBOOT	0x07	Reboot FLASH data content into register file
SAVE	0x08	Trigger emergency save to flash
SETFLSHADD	0x09	Flash page access ON
RSTFLSHADD	0x0A	Flash page access OFF
SETUSRFLSH	0x0B	User flash access ON (must be in flash page already)
RSTUSRFLSH	0x0C	User flash access OFF (return to flash page)

Table 24. 32-Bit Identification Code

MSB				LSB
	VERSION	PART NUMBER (16 BITS)	MANUFACTURER (11 BITS)	FIXED VALUE (1 BIT)
MAX16070	REV	1000000000000011	00011001011	1
MAX16071	REV	1000000000000100	00011001011	1

12-Channel/8-Channel, Flash-Configurable System Managers with Nonvolatile Fault Registers

Table 25. 32-Bit User-Code Data

MSB		LSB													
Don't Care	SMBus slave id	User ID (r8A[7:0])													
0000000000000000	See Table 20														

USERCODE: When the USERCODE instruction latches into the parallel instruction register, the user-code data register is selected. The device user-code loads into the user-code data register on the rising edge of TCK following entry into the capture-DR state. Shift-DR can be used to shift the user-code out serially through TDO. See Table 25. This instruction can be used to help identify multiple MAX16070/MAX16071 devices connected in a JTAG chain.

LOAD ADDRESS: This is an extension to the standard IEEE 1149.1 instruction set to support access to the memory in the MAX16070/MAX16071. When the LOAD ADDRESS instruction latches into the instruction register, TDI connects to TDO through the 8-bit memory address test data register during the shift-DR state.

READ DATA: This is an extension to the standard IEEE 1149.1 instruction set to support access to the memory in the MAX16070/MAX16071. When the READ instruction latches into the instruction register, TDI connects to TDO through the 8-bit memory read test data register during the shift-DR state.

WRITE DATA: This is an extension to the standard IEEE 1149.1 instruction set to support access to the memory in the MAX16070/MAX16071. When the WRITE instruction latches into the instruction register, TDI connects to TDO through the 8-bit memory write test data register during the shift-DR state.

REBOOT: This is an extension to the standard IEEE 1149.1 instruction set to initiate a software-controlled reset to the MAX16070/MAX16071. When the REBOOT instruction latches into the instruction register, the MAX16070/MAX16071 reset and immediately begin the boot-up sequence.

SAVE: This is an extension to the standard IEEE 1149.1 instruction set that triggers a fault log. The current ADC conversion results along with fault information are saved to flash depending on the configuration of the Critical Fault Log Control register (r6Dh).

SETFLSHADD: This is an extension to the standard IEEE 1149.1 instruction set that allows access to the flash page. Flash registers include ADC conversion results,

DACOUT enables, and GPIO_ input/output data. Use this page to access registers 200h to 2FFh

RSTFLSHADD: This is an extension to the standard IEEE 1149.1 instruction set. Use RSTFLSHADD to return to the default page and disable access to the flash page.

SETUSRFLSH: This is an extension to the standard IEEE 1149.1 instruction set that allows access to the user flash page. When on the configuration flash page, send the SETUSRFLSH command, all addresses are recognized as flash addresses only. Use this page to access registers 300h to 3FFh.

RSTUSRFLSH: This is an extension to the standard IEEE 1149.1 instruction set. Use RSTUSRFLSH to return to the configuration flash page and disable access to the user flash.

Restrictions When Writing to Flash

Flash must be written to 8 bytes at a time. The initial address must be aligned to 8-byte boundaries—the 3 LSBs of the initial address must be '000'. Write the 8 bytes using eight successive Write Data commands.

Applications Information

Device Behavior at Power-Up

When V_{CC} is ramped from 0, the RESET output is high impedance until V_{CC} reaches 1.4V, at which point RESET goes low. All other outputs are high impedance until V_{CC} reaches 2.7V, when the flash contents are copied into register memory. This takes 150μs (max), after which the outputs assume their programmed states.

Maintaining Power During a Fault Condition

Power to the MAX16070/MAX16071 must be maintained for a specific period of time to ensure a successful flash fault log operation during a fault that removes power to the circuit. Table 26 shows the amount of time required depends on the settings in the fault control register (r6Dh[1:0]).

Maintain power for shutdown during fault conditions in applications where the always-on power supply cannot be relied upon by placing a diode and a large capacitor between the voltage source, V_{IN}, and V_{CC} (Figure 14).

12-Channel/8-Channel, Flash-Configurable System Managers with Nonvolatile Fault Registers

MAX16070/MAX16071

The capacitor value depends on V_{IN} and the time delay required, t_{FAULT_SAVE} . Use the following formula to calculate the capacitor size:

$$C = (t_{FAULT_SAVE} \times I_{CC(MAX)}) / (V_{IN} - V_{DIODE} - V_{UVLO})$$

where the capacitance is in Farads and t_{FAULT_SAVE} is in seconds, $I_{CC(MAX)}$ is 14mA, V_{DIODE} is the voltage drop

across the diode, and V_{UVLO} is 2.7V. For example, with a V_{IN} of 14V, a diode drop of 0.7V, and a t_{FAULT_SAVE} of 153ms, the minimum required capacitance is 202 μ F.

Table 26. Maximum Write Time

R6Dh[1:0] VALUE	DESCRIPTION	MAXIMUM WRITE TIME (ms)
00	Save flags and ADC readings	153
01	Save flags	102
10	Save ADC readings	153
11	Do not save anything	—

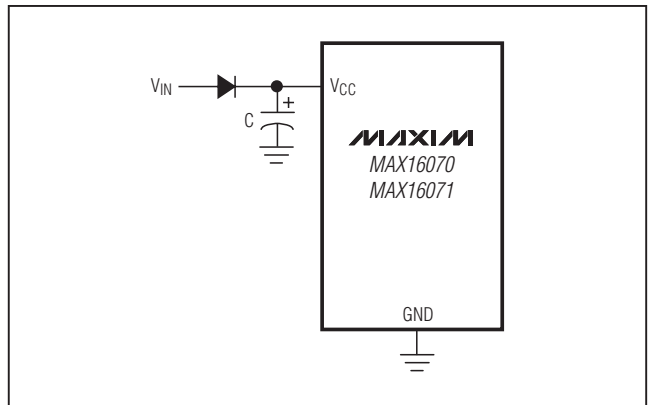

Figure 14. Power Circuit for Shutdown During Fault Conditions

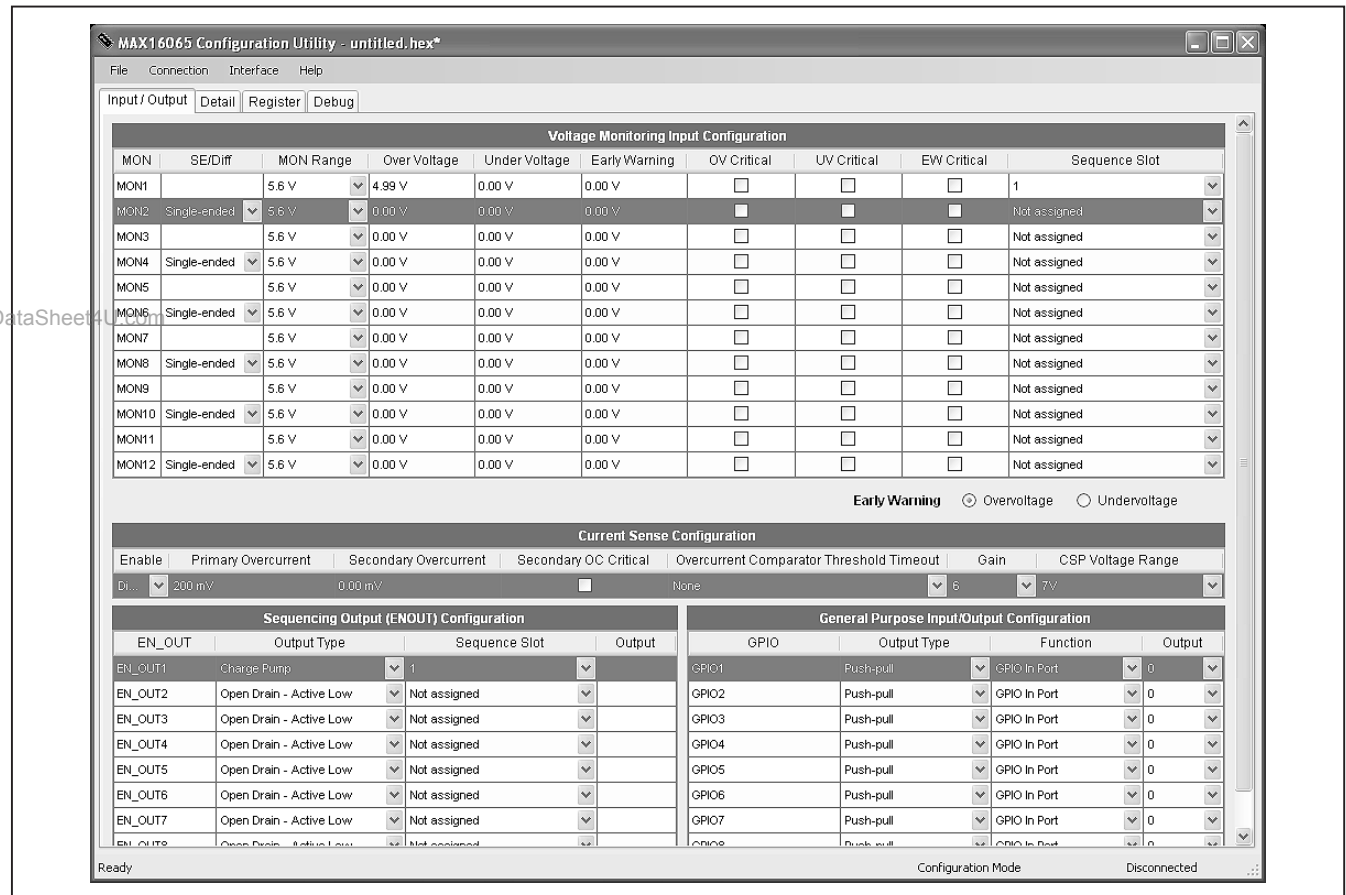

Figure 15. Graphical User Interface Screenshot

12-Channel/8-Channel, Flash-Configurable System Managers with Nonvolatile Fault Registers

Configuring the Device

An evaluation kit and a graphical user interface (GUI) is available to create a custom configuration for the device. Refer to the MAX16070/MAX16071 evaluation kit for configuration.

Cascading Multiple MAX16070/MAX16071s

Multiple MAX16070/MAX16071s can be cascaded to increase the number of monitored rails. There are many ways to cascade the devices depending on the desired behavior. In general, there are several techniques:

- Configure a GPIO_ on each device to be EXTFAULT (open drain). Externally wire them together with a single pullup resistor. Set register bits r72h[5] and r6Dh[2] to '1' so that all faults will propagate between devices. If a critical fault occurs on one device, EXTFAULT will assert, triggering the nonvolatile fault logger in all cascaded devices and recording a snapshot of all system voltages.
- Connect open-drain RESET outputs together to obtain a master system reset signal.
- Connect all EN inputs together for a master enable signal.

Monitoring Current Using the Differential Inputs

The MAX16070/MAX16071 can monitor up to seven currents using the dedicated current-sense amplifier as well as up to six pairs of inputs configured in differential mode. The accuracy of the differential pairs is limited by the voltage range and the 10-bit conversions. Each input pair uses an odd-numbered MON_ input in combination with an even-numbered MON_ input to monitor both the voltage from the odd-numbered MON_ to ground and the voltage difference between the two MON_ inputs. This way a single pair of inputs can monitor the voltage and the current of a power-supply rail. The overvoltage threshold on the even numbered MON_ input can be used as an overcurrent flag.

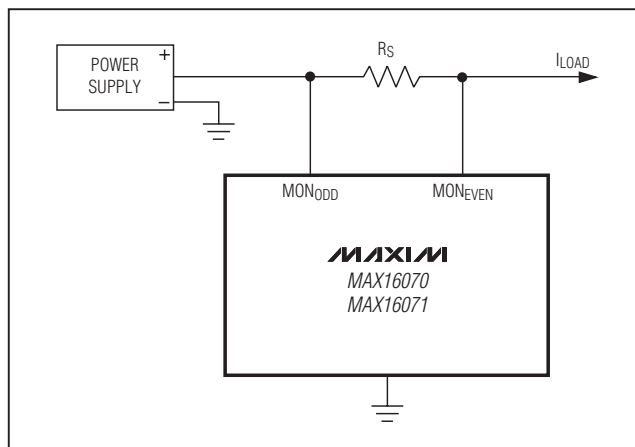

Figure 16. Current Monitoring Connection

Figure 16 shows how to connect a current-sense resistor to a pair of MON_ inputs for monitoring both current and voltage.

For best accuracy, set the voltage range on the even-numbered MON_ to 1.4V. Since the ADC conversion results are 10 bits, the monitoring precision is $1.4/1024 = 1.4\text{mV}$. For more accurate current measurements, use larger current-sense resistors. The application requirements should determine the balance between accuracy and voltage drop across the current-sense resistor.

Layout and Bypassing

Bypass DBP and ABP each with a $1\mu\text{F}$ ceramic capacitor to GND. Bypass VCC with a $10\mu\text{F}$ capacitor to ground. Avoid routing digital return currents through a sensitive analog area, such as an analog supply input return path or ABP's bypass capacitor ground connection. Use dedicated analog and digital ground planes. Connect the capacitors as close as possible to the device.

12-Channel/8-Channel, Flash-Configurable System Managers with Nonvolatile Fault Registers

Register Map

FLASH ADDRESS	REGISTER ADDRESS	READ/ WRITE	DESCRIPTION
ADC VALUES, FAULT REGISTERS, GPIO_S AS INPUT PORTS—NOT IN FLASH			
—	000	R	MON1 ADC output, MSBs
—	001	R	MON1 ADC output, LSBs
—	002	R	MON2 ADC output, MSBs
—	003	R	MON2 ADC output, LSBs
—	004	R	MON3 ADC output, MSBs
—	005	R	MON3 ADC output, LSBs
—	006	R	MON4 ADC output, MSBs
—	007	R	MON4 ADC output, LSBs
—	008	R	MON5 ADC output, MSBs
—	009	R	MON5 ADC output, LSBs
—	00A	R	MON6 ADC output, MSBs
—	00B	R	MON6 ADC output, LSBs
—	00C	R	MON7 ADC output, MSBs
—	00D	R	MON7 ADC output, LSBs
—	00E	R	MON8 ADC output, MSBs
—	00F	R	MON8 ADC output, LSBs
—	010	R	MON9 ADC output, MSBs
—	011	R	MON9 ADC output, LSBs
—	012	R	MON10 ADC output, MSBs
—	013	R	MON10 ADC output, LSBs
—	014	R	MON11 ADC output, MSBs
—	015	R	MON11 ADC output, LSBs
—	016	R	MON12 ADC output, MSBs
—	017	R	MON12 ADC output, LSBs
—	018	R	Current-sense ADC output
—	019	R	CSP ADC output, MSBs
—	01A	R	CSP ADC output, LSBs
—	01B	R/W	Fault register--failed line flags
—	01C	R/W	Fault register—failed line flags/overcurrent
—	01D	R	Reserved
—	01E	R	GPIO data in (read only)
—	01F	R	Reserved
—	020	R/W	Flash status/reset output monitor
—	021	R	Reserved

MAX16070/MAX16071

www.DataSheet4U.com

12-Channel/8-Channel, Flash-Configurable System Managers with Nonvolatile Fault Registers

Register Map (continued)

FLASH ADDRESS	REGISTER ADDRESS	READ/ WRITE	DESCRIPTION
GPIO AND OUTPUT DEPENDENCIES/CONFIGURATIONS			
230	030	R/W	Reserved
231	031	R/W	Reserved
232	032	R/W	Reserved
233	033	R/W	Reserved
234	034	R/W	Reserved
235	035	R/W	SMBALERT pin configuration
236	036	R/W	Fault1 dependencies
237	037	R/W	Fault1 dependencies
238	038	R/W	Fault2 dependencies
239	039	R/W	Fault2 dependencies
23A	03A	R/W	Fault1/Fault2 secondary overcurrent dependencies
23B	03B	R/W	RESET output configuration
23C	03C	R/W	RESET output dependencies
23D	03D	R/W	RESET output dependencies
23E	03E	R/W	GPIO data out
23F	03F	R/W	GPIO configuration
240	040	R/W	GPIO configuration
241	041	R/W	GPIO configuration
242	042	R/W	GPIO push-pull/open drain
ADC—CONVERSIONS			
243	043	R/W	ADCs voltage ranges—MON_ monitoring
244	044	R/W	ADCs voltage ranges—MON_ monitoring
245	045	R/W	ADCs voltage ranges—MON_ monitoring
246	046	R/W	Differential pairs enables
247	047	R/W	Current-sense gain-setting (CSP, HV or LV)
INPUT THRESHOLDS			
248	048	R/W	MON1 secondary selectable UV/OV
249	049	R/W	MON1 primary OV
24A	04A	R/W	MON1 primary UV
24B	04B	R/W	MON2 secondary selectable UV/OV
24C	04C	R/W	MON2 primary OV
24D	04D	R/W	MON2 primary UV
24E	04E	R/W	MON3 secondary selectable UV/OV
24F	04F	R/W	MON3 primary OV
250	050	R/W	MON3 primary UV
251	051	R/W	MON4 secondary selectable UV/OV
252	052	R/W	MON4 primary OV
253	053	R/W	MON4 primary UV

12-Channel/8-Channel, Flash-Configurable System Managers with Nonvolatile Fault Registers

Register Map (continued)

FLASH ADDRESS	REGISTER ADDRESS	READ/ WRITE	DESCRIPTION
254	054	R/W	MON5 secondary selectable UV/OV
255	055	R/W	MON5 primary OV
256	056	R/W	MON5 primary UV
257	057	R/W	MON6 secondary selectable UV/OV
258	058	R/W	MON6 primary OV
259	059	R/W	MON6 primary UV
25A	05A	R/W	MON7 secondary selectable UV/OV
25B	05B	R/W	MON7 primary OV
25C	05C	R/W	MON7 primary UV
25D	05D	R/W	MON8 secondary selectable UV/OV
25E	05E	R/W	MON8 primary OV
25F	05F	R/W	MON8 primary UV
260	060	R/W	MON9 secondary selectable UV/OV
261	061	R/W	MON9 primary OV
262	062	R/W	MON9 primary UV
263	063	R/W	MON10 secondary selectable UV/OV
264	064	R/W	MON10 primary OV
265	065	R/W	MON10 primary UV
266	066	R/W	MON11 secondary selectable UV/OV
267	067	R/W	MON11 primary OV
268	068	R/W	MON11 primary UV
269	069	R/W	MON12 secondary selectable UV/OV
26A	06A	R/W	MON12 primary OV
26B	06B	R/W	MON12 primary UV
26C	06C	R/W	Secondary overcurrent threshold
FAULT SETUP			
26D	06D	R/W	Save after $\overline{\text{EXTFAULT}}$ fault control
26E	06E	R/W	Faults causing store in flash
26F	06F	R/W	Faults causing store in flash
270	070	R/W	Faults causing store in flash
271	071	R/W	Faults causing store in flash
272	072	R/W	Faults causing store in flash
TIMEOUTS			
273	073	R/W	Overcurrent debounce, watchdog mode, secondary threshold type, software enables
274	074	R/W	ADC fault deglitch configuration
275	075	R/W	WDI toggle
276	076	R/W	Watchdog reset output enable, watchdog timers
277	077	R/W	Boot-up delay

MAX16070/MAX16071

www.DataSheet4U.com

12-Channel/8-Channel, Flash-Configurable System Managers with Nonvolatile Fault Registers

Register Map (continued)

FLASH ADDRESS	REGISTER ADDRESS	READ/ WRITE	DESCRIPTION
278	078	R/W	Reserved
279	079	R/W	Reserved
27A	07A	R/W	Reserved
27B	07B	R/W	Reserved
27C	07C	R/W	Reserved
27D	07D	R/W	Reserved
MISCELLANEOUS			
27E	07E	R/W	Reserved
27F	07F	R/W	Reserved
280	080	R/W	Reserved
281	081	R/W	Reserved
282	082	R/W	Reserved
283	083	R/W	Reserved
284	084	R/W	Reserved
285	085	R/W	Reserved
286	086	R/W	Reserved
287	087	R/W	Reserved
288	088	R/W	Reserved
289	089	R/W	Reserved
28A	08A	R/W	Customer use (version)
28B	08B	R/W	PEC enable/I ² C address
28C	08C	R/W	Lock bits
28D	08D	R	Revision code
NONVOLATILE FAULT LOG			
200	—	R/W	Reserved
201	—	R/W	FAULT flags, MON1–MON8
202	—	R/W	FAULT flags, MON9–MON12, EXTFAULT
203	—	R/W	MON1 ADC output
204	—	R/W	MON2 ADC output
205	—	R/W	MON3 ADC output
206	—	R/W	MON4 ADC output
207	—	R/W	MON5 ADC output
208	—	R/W	MON6 ADC output
209	—	R/W	MON7 ADC output
20A	—	R/W	MON8 ADC output
20B	—	R/W	MON9 ADC output
20C	—	R/W	MON10 ADC output
20D	—	R/W	MON11 ADC output
20E	—	R/W	MON12 ADC output
20F	—	R/W	Current-sense ADC output

www.DataSheet4U.com

12-Channel/8-Channel, Flash-Configurable System Managers with Nonvolatile Fault Registers

MAX16070/MAX16071

Register Map (continued)

FLASH ADDRESS	REGISTER ADDRESS	READ/ WRITE	DESCRIPTION
USER FLASH			
300	39F	R/W	User flash
3A0	3AF	—	Reserved
3B0	3FF	R/W	User flash

Typical Operating Circuits

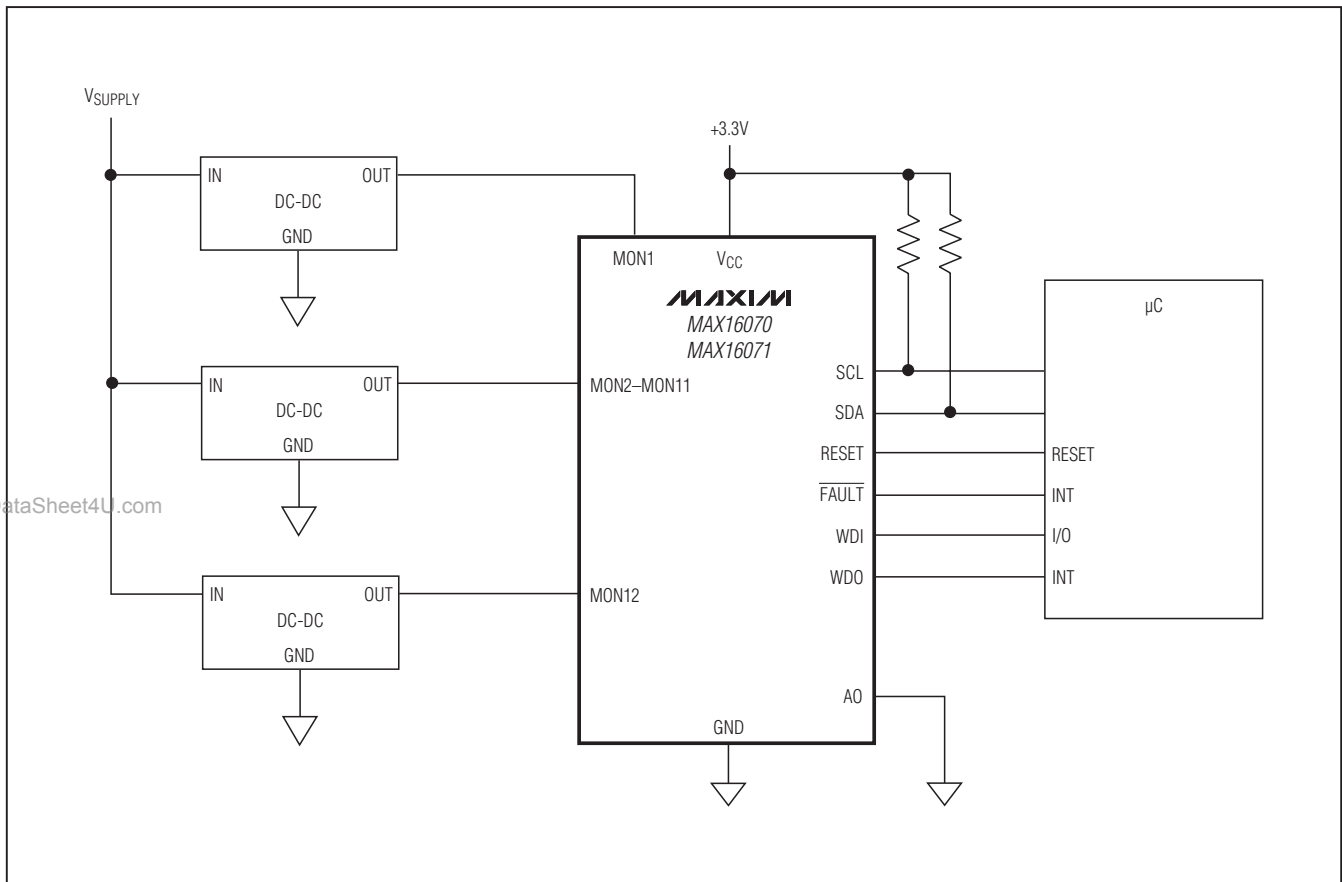

www.DataSheet4U.com

12-Channel/8-Channel, Flash-Configurable System Managers with Nonvolatile Fault Registers

Typical Operating Circuits (continued)

MAX16070/MAX16071

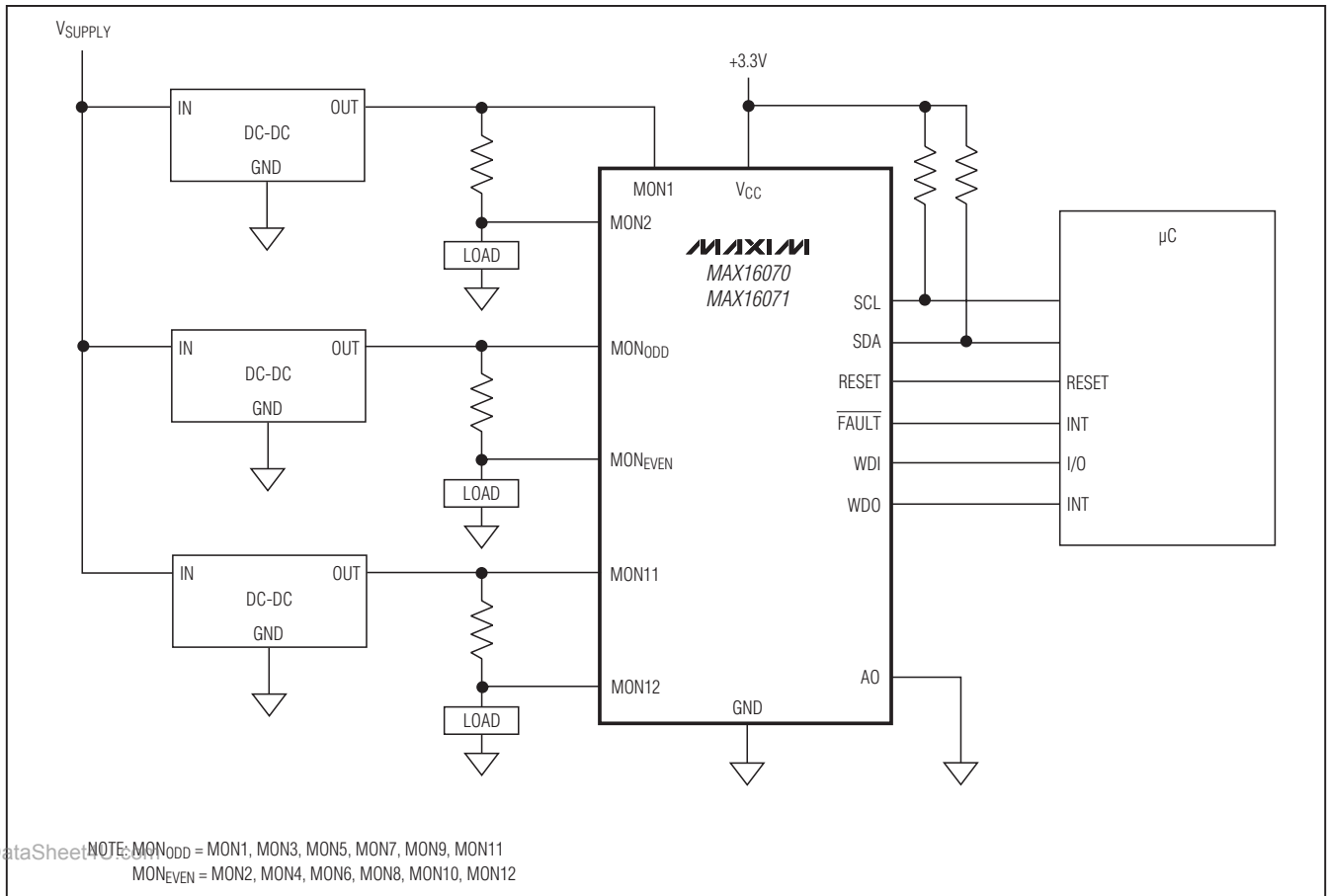

www.DataSheet4U.com

12-Channel/8-Channel, Flash-Configurable System Managers with Nonvolatile Fault Registers

Pin Configurations

MAX16070/MAX16071

TOP VIEW

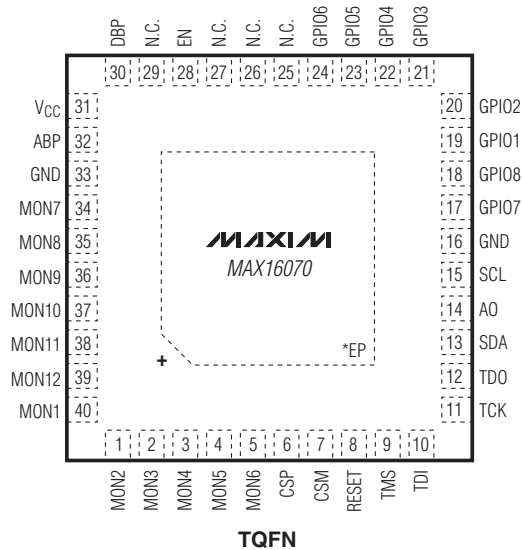

www.DataSheet4U.com

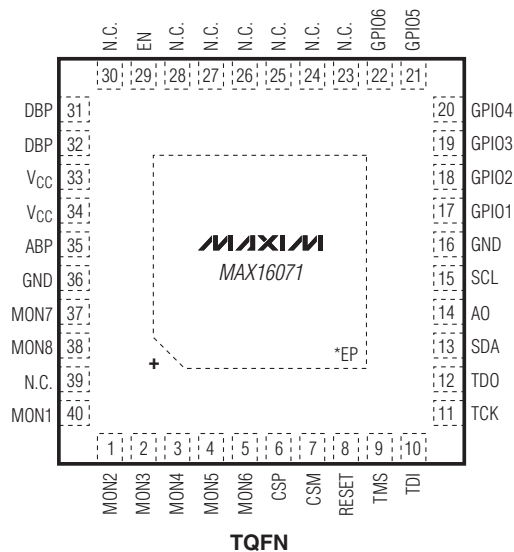

12-Channel/8-Channel, Flash-Configurable System Managers with Nonvolatile Fault Registers

Chip Information

PROCESS: BiCMOS

Package Information

For the latest package outline information and land patterns, go to www.maxim-ic.com/packages. Note that a "+", "#", or "-" in the package code indicates RoHS status only. Package drawings may show a different suffix character, but the drawing pertains to the package regardless of RoHS status.

PACKAGE TYPE	PACKAGE CODE	DOCUMENT NO.
40 TQFN-EP*	T4066-5	21-0141

MAX16070/MAX16071