



UU642

Preliminary

LINEAR INTEGRATED CIRCUIT

INTERVAL AND WIPE/WASH WIPER CONTROL IC

DESCRIPTION

The bipolar integrated circuit UTC **UU642** is designed as a wiper for automotive application. It includes wipe, wash and interval mode.

The UTC **UU642** is a cost-effective solution for an accurate timing function control. Wipe/wash mode has priority over interval mode. Interval pause and after-wiping time can be set to fixed values by using resistors in a broad time range. Added value can be provided with an individual, continuous adjustment of the interval pause by a potentiometer which may be built into the stalk. For proper operation, it is mandatory to feed the signal of the wiper motor's park switch into UTC **UU642**.

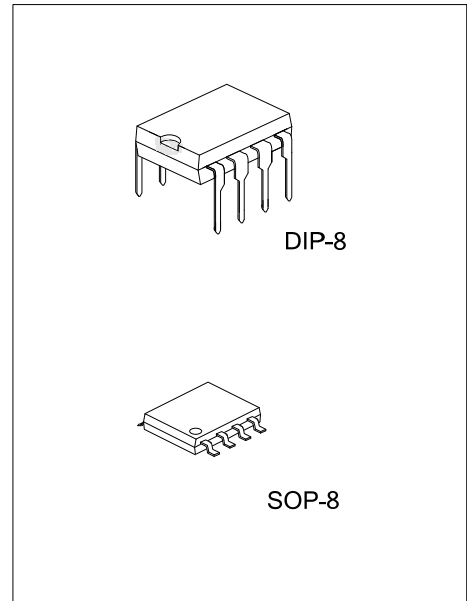

FEATURES

- * After-wiping time: 2s~20s
- * Interval pause: 4s~20s
- * Wipe/wash mode priority
- * Wiper motor's park switch
- * Relay driver with Z-diode
- * One external capacitor determines all time sequences
- * Interference protection according to VDE 0839 or ISO/TR 637/1
- * Load-dump protected

ORDERING INFORMATION

Ordering Number		Package Packing	
Lead Free	Halogen Free		
UU642L-D08-T UU64	2G-D08-T	DIP-8	Tube
UU642L-S08-T UU64	2G-S08-T	SOP-8	Tube
UU642L-S08-R UU64	2G-S08-R	SOP-8	Tape Reel

UU642L-D08-R (1) Packing Type (2) Package Type (3) Halogen Free	(1) T: Tube, R: Tape Reel (2) D08: DIP-8, S08: SOP-8 (3) L: Lead Free, G: Halogen Free
--	--

■ PIN CONFIGURATION

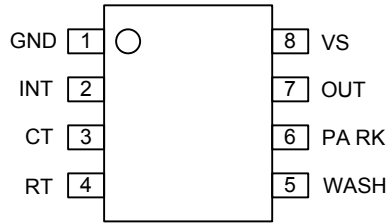

■ PIN DESCRIPTION

PIN NO.	PIN NAME	DESCRIPTION
1	GND	Ground
2	INT	Interval switch
3	CT	Timing capacitor C_2
4	RT	After-wiping time resistance
5	W	Wipe/wash switch
6	PARK	Park switch for wiper motor
7	OUT	Relay control output
8	VS	Supply voltage terminal 15

■ BLOCK DIAGRAM

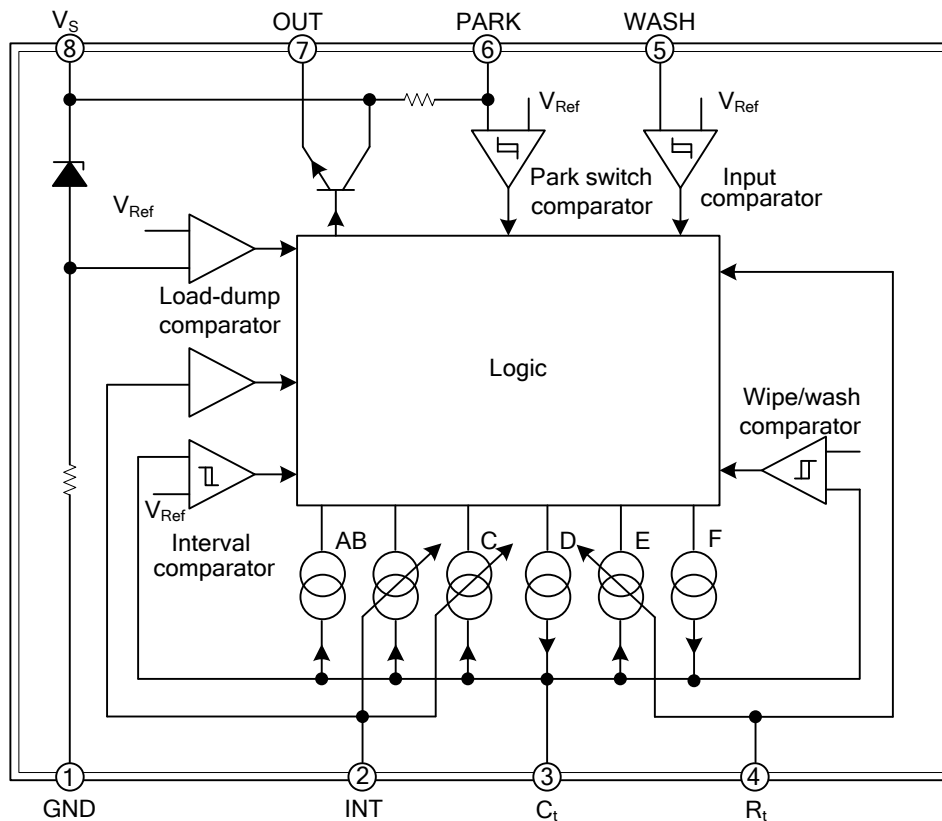

■ ABSOLUTE MAXIMUM RATING

PARAMETER SYMBOL			RATINGS	UNIT
Supply Voltage t=60s, Terminal 15		V_{Batt} 28		V
Supply Current	t=2ms	I_8	1.5	A
	t=200ms		150	mA
Relay Control Output Current (DC)		I_7	200	mA
Relay Control Output Current (DC) t=200ms			1.2	A
Pulse Current (Control Inputs) t=200ms				
Park Switch, S_1		I_6 50		mA
Wipe/Wash Switch, S_3		I_5 50		mA
Interval Switch, S_2		I_2 50		mA
Power Dissipation $T_{AMB}=90^{\circ}C$ P		P_D 500		mW
Ambient Temperature Range		T_A -4	0~+85	$^{\circ}C$
Storage Temperature Range		T_{STG} -55~	+125	$^{\circ}C$

Note: Absolute maximum ratings are those values beyond which the device could be permanently damaged.
Absolute maximum ratings are stress ratings only and functional device operation is not implied.

■ THERMAL RESISTANCE

PARAMETER SYMBOL			RATINGS	UNIT
Junction to Ambient	DIP-8	θ_{JA}	120 K/W	
	SOP-8		160	K/W

■ ELECTRICAL CHARACTERISTICS

($V_{Batt}=12V$, $T_A=25^\circ C$, reference point is pin 8, unless otherwise specified.)

PARAMETER SYMBOL		TEST CONDITIONS	MIN	TYP	MAX	UNIT
Supply Voltage	V_{Batt}		9		16.5	V
Supply Current	I_8		9			mA
Z-Diode Limitation	V_1		6			V
Overvoltage						
Threshold Current	I_1		-94			mA
Threshold Voltage	V_{Batt}		37			V
Relay Control Output						
Saturation Voltage	V_7	$I_7=100mA$			-1.0	V
		$I_7=200mA$			-1.5	V
Leakage Current	I_7			100		μA
Park Switch						
Internal Pull-Up Resistance	R_6	$R_6=10k\Omega$		41		k Ω
Switching Threshold Voltage	V_6			-3.1		V
Protection Diode	V_6	$I_6=-10mA$		-0.8		V
		$I_6=10mA$		7.6		V
Input C_t						
Internal Resistance	R_3			100		Ω
Interval Input $R_2=2.7\sim 30k\Omega$						
Protection Diode	V_2	$I_2=-10mA$		-0.8		V
		$I_2=30mA/10ms$		5.6		V
WASH Input $R_5=10k\Omega$						
Switching Threshold/Hysteresis	V_5		-1.1	-7.1		V
Protection Diode	V	$I_5=-10mA$		-0.87		V
		$I_5=10mA$		8.7		V
Switching Characteristics $R_4=47k\Omega\sim 300k\Omega$, $I_4=-150\mu A$						
Interval Time	t_2	$R_3=0k\Omega$		3.45		s
		$R_3=10k\Omega$		10.8		s
Prewash Delay	t_{del}		80			ms
After-Wipe-Time	t_5	$R_4=130k\Omega$		4.7		s

■ TYPICAL APPLICATION CIRCUIT

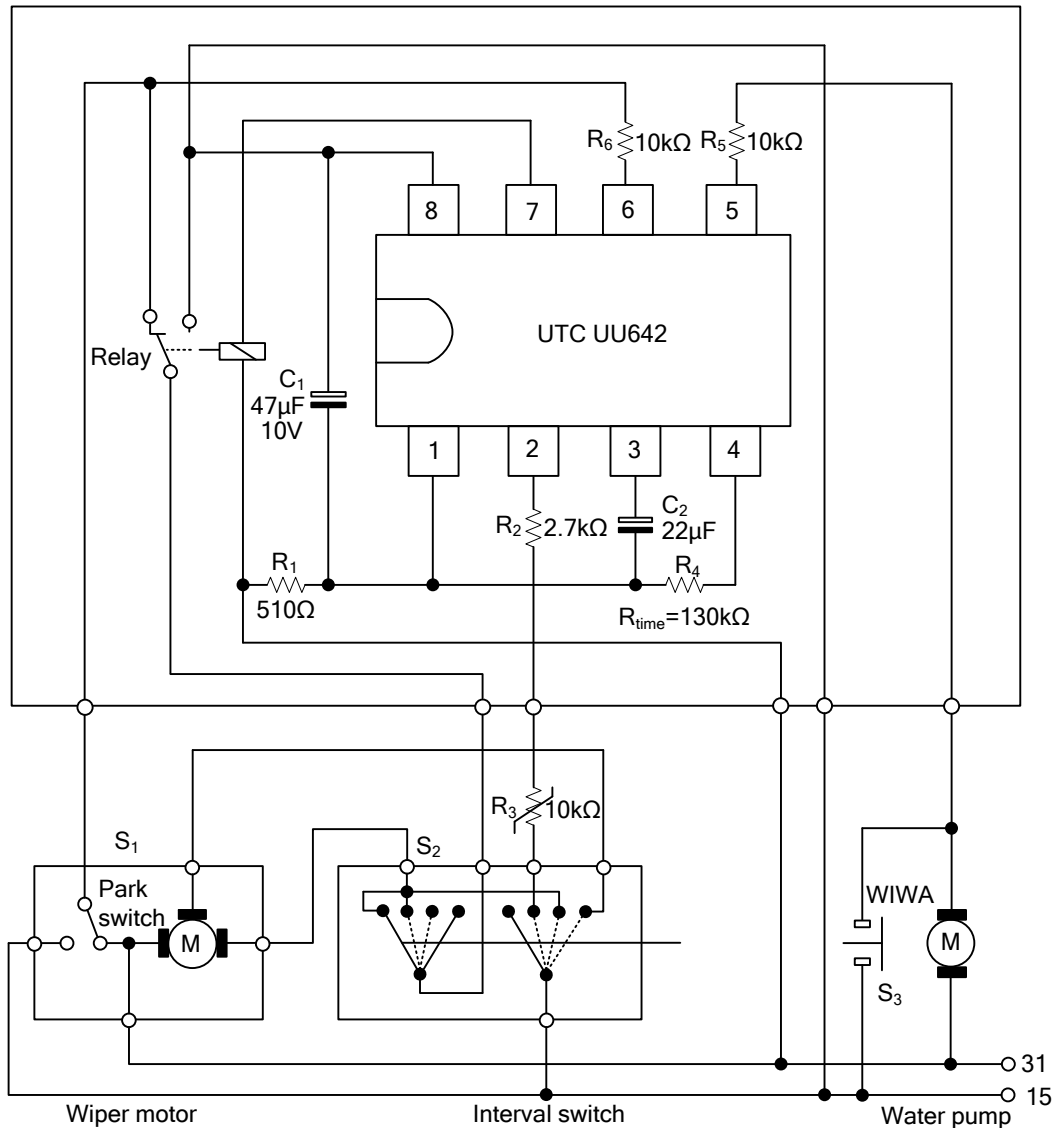

UTC assumes no responsibility for equipment failures that result from using products at values that exceed, even momentarily, rated values (such as maximum ratings, operating condition ranges, or other parameters) listed in products specifications of any and all UTC products described or contained herein. UTC products are not designed for use in life support appliances, devices or systems where malfunction of these products can be reasonably expected to result in personal injury. Reproduction in whole or in part is prohibited without the prior written consent of the copyright owner. The information presented in this document does not form part of any quotation or contract, is believed to be accurate and reliable and may be changed without notice.