

深圳市华田信科科技有限公司

SHENZHEN HTDISPLAY TECHNOLOGY CO.,LTD

规格书

SPECIFICATION

CONTENTS

NO.	ITEM	PAGE
1.	COVER	1
2.	RECORD OF REVISION	2
3.	GENERAL SPECIFICATION	3
4.	MECHANICAL DATA	3
5.	ABSOLUTE MAXIMUM RATINGS	4
6.	ELECTRICAL CHARACTERISTICS	5
7.	OPTICAL CHARACTERISTICS	5
8.	OUTLINE DIMENSION	6~7
9.	BLOCK DIAGRAM	7
10	INTERFACE TIMING CHART	8~9
11	INSTRUCTION CODE	10~11
12	CHARACTER GENERATOR ROM	12

ACCEPTED BY:

PROPOSED BY:

RECORD OF REVISION

www.DataSheet4U.com

DATE	PAGE	SUMMARY

3. General specifications

3.1 General specifications

www.DataSheet4U.com

PLEASE REFER TO:

“CUSTOMER ACCEPTANCE STANDARD SPECIFICATIONS (MS-10-10000)”.

3.2 Quality Assurance and Warranty

PLEASE REFER TO:

“QUALITY ASSURANCE MANUL (MS-10-10001)”.

3.3 This individual specification is prior to general specifications

4. Mechanical data

- Display format: 16 characters x 2 lines
- Microprocessor interface: 8 bits Par all
- LCD type: STN negative,Blue ,
 - Backlight color: white
- Viewing angle: 6 o'clock
- LCD controller: KS0066+KS0065
- Module size: 80x 36 mm
- View area: 64x16 mm
- Dot size: 0.55x 0.5 mm
- Dot pitch: 0.6 x 0.55mm
- Driving method: 1/16 duty, 1/5 bias
- RoHS regulation: To our best knowledge, this product satisfies material requirement of RoHS regulation. Our company is doing the best efforts to Obtain the equivalent certificate from our suppliers.

5. Absolute maximum ratings

5.1 Electrical absolute maximum ratings

www.DataSheet4U.com

I T E M	SYMBOL	MIN.	MAX.	UNIT	COMMENT
POWER SUPPLY FOR LOGIC	$V_{DD}-V_{SS}$	-0.3	6	V	-----
INPUT VOLTAGE	V_I	V_{SS}	V_{DD}	V	-----
STATIC ELECTRICITY	-----	-----	-----	V	
POWER SUPPLY FOR BACKLIGHT	V_S	-----	4.2	V_{rms}	-----
	f_{FL}	-----	-----	KHz	-----
STARTING VOLTAGE FOR BACKLIGHT	-----	-----	-----	V_{rms}	$T_a = 25^{\circ}C$
	-----	-----	-----	V_{rms}	$T_a = 25^{\circ}C$
POWER SUPPLY FOR LCD	$V_{DD}-V_0$	-----	4.7	V	-----

5.2 Environmental absolute maximum ratings

I T E M	OPERATING		STORAGE		COMMENT
	MIN.	MAX.	MIN.	MAX.	
AMBIENT TEMPERATURE	-20°C	70°C	-30°C	80°C	-----
HUMIDITY	NOTE (2)		NOTE (2)		NO CONDENSATION
VIBRATION NOTE (3)	-----	0.5G	-----	2G	10~300Hz XYZ DIRECTIONS 1 Hr EACH
SHOCK NOTE (3)	-----	3G	-----	5G	10 msec XYZ DIRECTIONS 1 TIME EACH
CORROSIVE GAS	NOT ACCEPTABLE		NOT ACCEPTABLE		-----

NOTE (2): $T_a \leq 70^{\circ}C$: 75% RH MAX.

$T_a > 70^{\circ}C$: ABSOLUTE HUMIDITY MUST BE LOWER THAN THE HUMIDITY OF 75% RH AT 70°C.

NOTE (3): 1G = 9.8 m/s²

6. Electrical characteristics

Ta = 25°C VDD = 5.0V

I T E M	SYMBOL	CONDITION	MIN.	TYP.	MAX.	UNIT
Power supply voltage for circuit	VDD-VSS	-----	4.5	5.0	5.5	V
Power supply voltage for LCD drive	VDD-V0	-----	-----	4.7	-----	V
LCD display duty ratio	DUTY	-----	-----	1/16	-----	-----
LED BACKLIGHT	Ifp	I mse0 plus 10% Dutg cyele		-----		mA
		Operating voltage	-----	4.1	-----	V
		Forward current		80		mA
LED Lifetime	-----	VFL=4.1Vrms fFL= KHZ	-----	100,000	-----	Hr
Power supply LCD current	IEE	VDD-V0= 4.7 V	-----	----	-----	mA

LED backlight: Due to the LED backlight working current is XXX Max, and LED chips Vop may be different, Wincom will adjust the backlight resistor according to the LED chips Vop, to meet the brightness maximum.

7. Optical characteristics

Ta = 25°C VDD-V0 = 4.7V

I T E M	SYMBOL	CONDITION	MIN.	TYP.	MAX.	UNIT	NOTE
Viewing angle	$\Phi 2-\Phi 1$	$K \geq 2.0$	-35	-----	20	deg.	1
Contrast ratio	K	$\Phi = 10^0$ $\theta = 0^0$	4.0	-----	-----	-----	1
Response time (at 25°C)	tr (rise)	$\Phi = 10^0$ $\theta = 0^0$	-----	-----	250	ms	1
	tf (fall)	$\Phi = 10^0$ $\theta = 0^0$	-----	-----	250	ms	1
The brightness of backlighting source	B	VFL=4.1Vrms fFL= KHZ	-----	-----	-----	cd/m ²	2

NOTE (1): SEE CUSTOMER ACCEPTANCE STANDARD SPECIFICATION FOR DEFINITION OF OPTICAL CHARACTERISTICS

NOTE (2): UNDER NORMAL TEMPERATURE AND HUMIDITY IN A DARK ROOM

8. Outline dimension

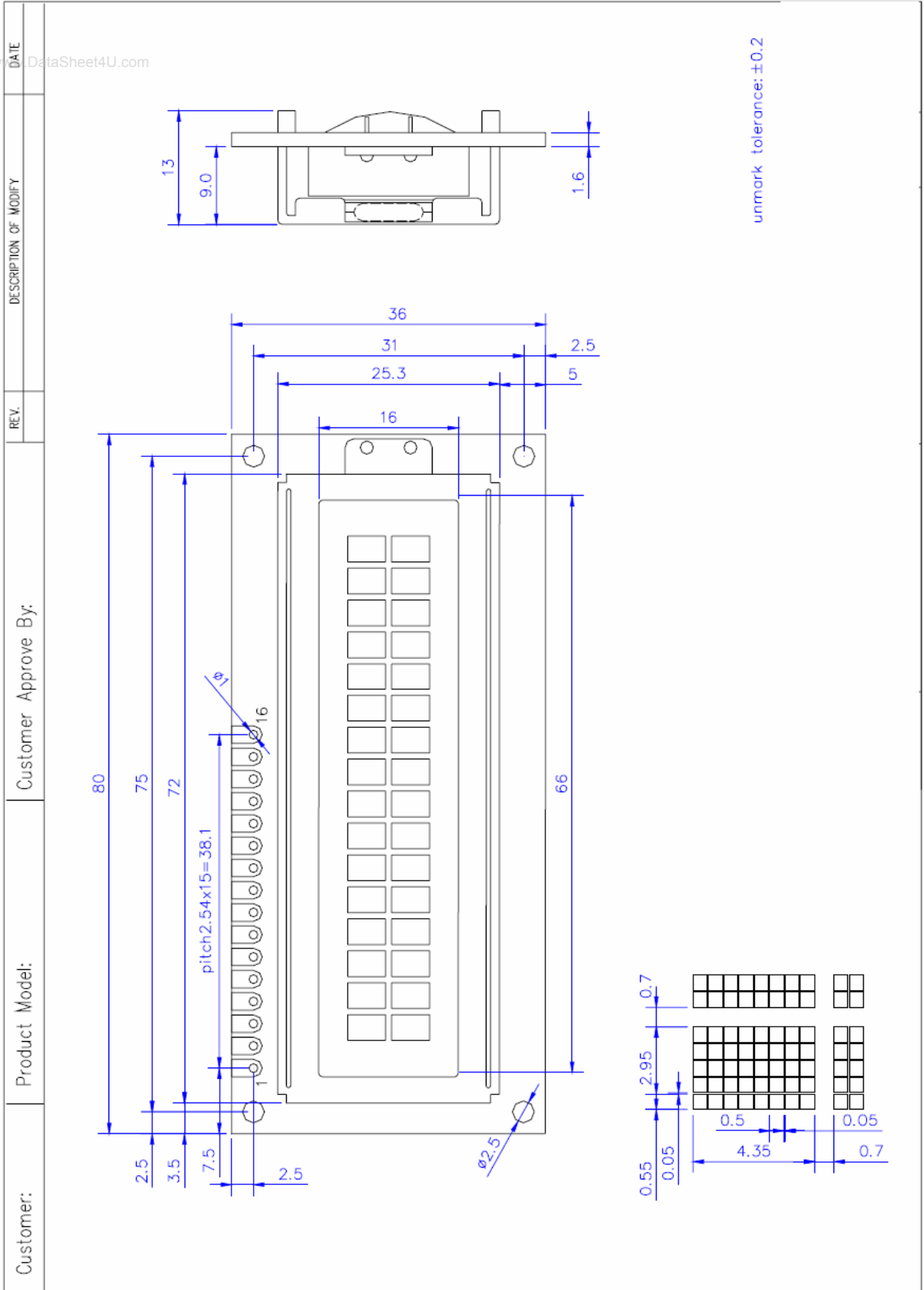

UNIT:mm

8.1 Interface

Pin Assignment

PIN NO.	Symbol	Level	Function
1	V _{SS}	0V	Ground
2	V _{DD}	5.0V	Power supply voltage for LCM(+)
3	V ₀	-----	Contrast Adjust
4	RS	H/L	Register select signal
5	R/W	H/L	Data read / write
6	E	H/L	Enable signal
7	DB0	H/L	Data bus line
8	DB1	H/L	Data bus line
9	DB2	H/L	Data bus line
10	DB3	H/L	Data bus line
11	DB4	H/L	Data bus line
12	DB5	H/L	Data bus line
13	DB6	H/L	Data bus line
14	DB7	H/L	Data bus line
15	A	(+5.0V)	Power supply for LED BL (+)
16	K	(-)	Power supply for LED BL (-)

9. Block diagram

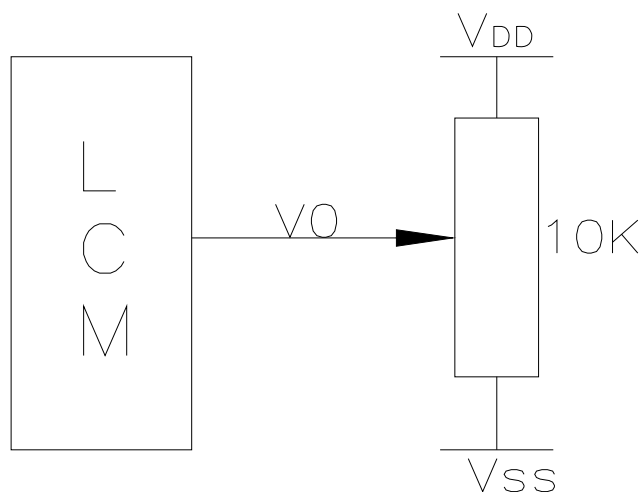
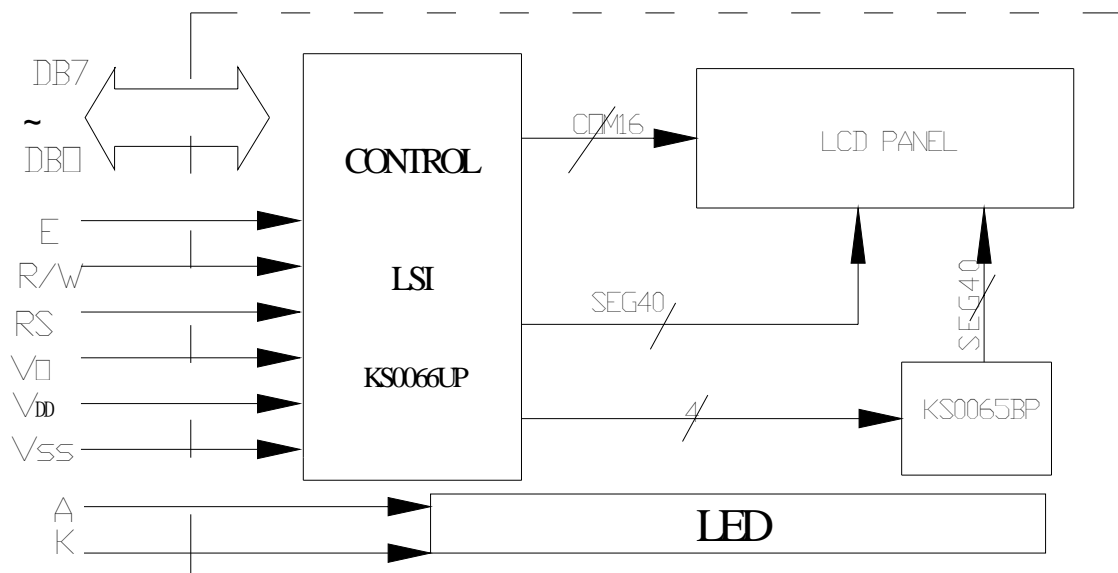

10. Interface Timing Chart

AC Characteristics($V_{DD}=4.5V\sim 5.5V, T_a=-30\sim +85^{\circ}C$)

Mode	Characteristic	Symbol	Min.	Typ.	Max.	Unit
Write Mode (Refer to Fig-6)	E Cycle Time	t_c	500	-	-	ns
	E Rise / Fall Time	t_R, t_F	-	-	20	
	E Pulse Width (High, Low)	t_w	230	-	-	
	R/W and RS Setup Time	t_{su1}	40	-	-	
	R/W and RS Hold Time	t_{H1}	10	-	-	
	Data Setup Time	t_{su2}	80	-	-	
	Data Hold Time	t_{H2}	10	-	-	
Read Mode (Refer to Fig-7)	E Cycle Time	t_c	500	-	-	ns
	E Rise / Fall Time	t_R, t_F	-	-	20	
	E Pulse Width (High, Low)	t_w	230	-	-	
	R/W and RS Setup Time	t_{su}	40	-	-	
	R/W and RS Hold Time	t_H	10	-	-	
	Data Output Delay Time	t_D	-	-	120	
	Data Hold Time	t_{DH}	5	-	-	

Timing Characteristics

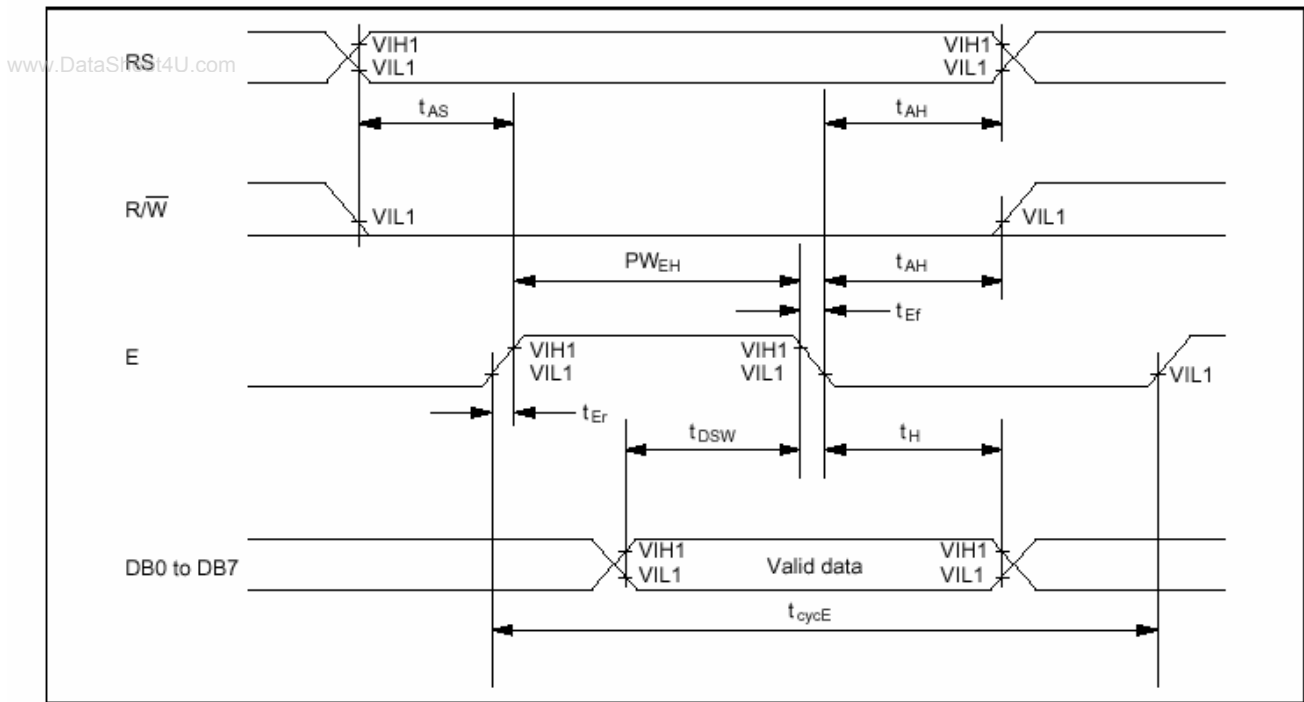

Write Operation

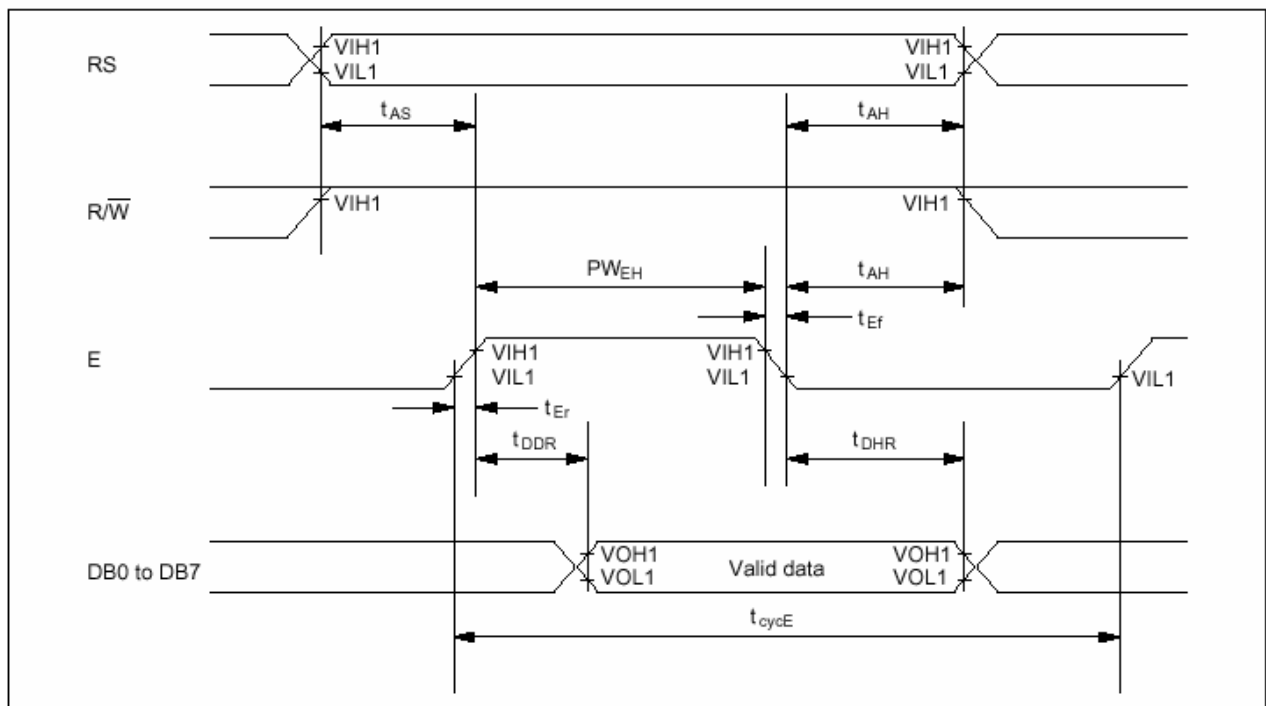

Read Operation

11. Instruction Code

Instruction Table

Instruction	Instruction Code										Description	Execution time (fosc= 270 kHz)	
	RS	R/W	DB7	DB6	DB5	DB4	DB3	DB2	DB1	DB0			
Clear Display	0	0	0	0	0	0	0	0	0	1	Write "20H" to DDRAM and set DDRAM address to "00H" from AC	1.53 ms	
Return Home	0	0	0	0	0	0	0	0	0	1	-	Set DDRAM address to "00H" from AC and return cursor to its original position if shifted. The contents of DDRAM are not changed.	1.53 ms
Entry Mode Set	0	0	0	0	0	0	0	0	1	I/D	SH	Assign cursor moving direction and enable the shift of entire display.	39 μs
Display ON/OFF Control	0	0	0	0	0	0	0	1	D	C	B	Set display(D), cursor(C), and blinking of cursor(B) on/off control bit.	39 μs
Cursor or Display Shift	0	0	0	0	0	0	1	S/C	R/L	-	-	Set cursor moving and display shift control bit, and the direction, without changing of DDRAM data.	39 μs
Function Set	0	0	0	0	0	1	DL	N	F	-	-	Set interface data length (DL: 8-bit/4-bit), numbers of display line (N: 2-line/1-line) and, display font type (F:5×11dots/5×8 dots)	39 μs
Set CGRAM Address	0	0	0	1	AC5	AC4	AC3	AC2	AC1	AC0		Set CGRAM address in address counter.	39 μs
Set DDRAM Address	0	0	1	AC6	AC5	AC4	AC3	AC2	AC1	AC0		Set DDRAM address in address counter.	39 μs
Read Busy Flag and Address	0	1	BF	AC6	AC5	AC4	AC3	AC2	AC1	AC0		Whether during internal operation or not can be known by reading BF. The contents of address counter can also be read.	0 μs
Write Data to RAM	1	0	D7	D6	D5	D4	D3	D2	D1	D0		Write data into internal RAM (DDRAM/CGRAM).	43 μs
Read Data from RAM	1	1	D7	D6	D5	D4	D3	D2	D1	D0		Read data from internal RAM (DDRAM/CGRAM).	43 μs

* "-": don't care

NOTE: When an MPU program with checking the Busy Flag(DB7) is made, it must be necessary 1/2Fosc is necessary for executing the next instruction by the falling edge of the 'E' signal after the Busy Flag (DB7) goes to "Low".

8-bit interface mode (Condition: fosc = 270KHZ)

www.DataSheet4U.com

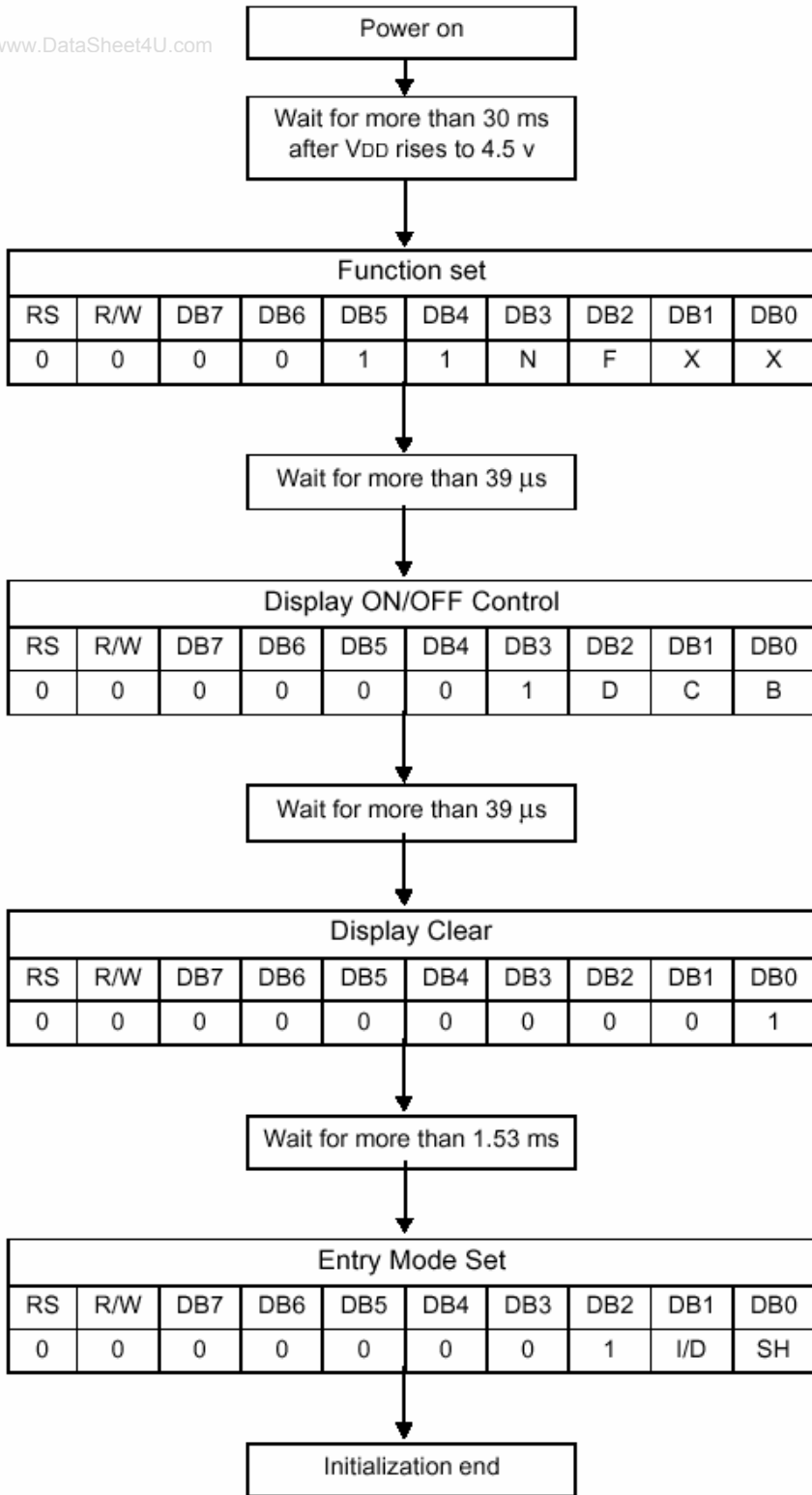

N	0	1-line mode
	1	2-line mode

F	0	display off
	1	display on

D	0	display off
	1	display on

C	0	cursor off
	1	cursor on

B	0	blink off
	1	blink on

I/D	0	decrement mode
	1	increment mode

SH	0	entire shift off
	1	entire shift on

12.Character generator ROM

Lower 4 Bits \ Upper 4 Bits	0000	0010	0011	0100	0101	0110	0111	1010	1011	1100	1101	1110	1111
xxxx0000	CG RAM (1)		0	a	P	`	P		-	9	3	α	ρ
xxxx0001	(2)	!	1	A	Q	a	9	o	ア	チ	△	ä	g
xxxx0010	(3)	"	2	B	R	b	r	「	イ	ツ	×	β	θ
xxxx0011	(4)	#	3	C	S	c	s	」	ウ	テ	ε	ε	ω
xxxx0100	(5)	\$	4	D	T	d	t	、	エ	ト	ト	μ	Ω
xxxx0101	(6)	%	5	E	U	e	u	・	オ	ナ	1	ε	ü
xxxx0110	(7)	&	6	F	V	f	v	ヲ	カ	ニ	ヨ	ρ	Σ
xxxx0111	(8)	'	7	G	W	g	w	ア	キ	ヌ	ラ	g	π
xxxx1000	(1)	(8	H	X	h	x	イ	ク	ネ	リ	γ	×
xxxx1001	(2))	9	I	Y	i	y	ウ	ケ	ル	ル	'	γ
xxxx1010	(3)	*	:	J	Z	j	z	エ	コ	ン	レ	j	κ
xxxx1011	(4)	+	;	K	L	k	l	オ	サ	ヒ	ロ	*	κ
xxxx1100	(5)	,	<	L	¥	1	1	パ	シ	フ	ワ	φ	円
xxxx1101	(6)	-	=	M	J	m	j	ユ	ス	ハ	ン	も	÷
xxxx1110	(7)	.	>	N	^	n	→	ヨ	セ	ホ	°	ñ	
xxxx1111	(8)	/	?	O	_	o	+	ツ	リ	マ	°	ö	■