

ESD protected N-CHANNEL MOSFET
MTNK3C3

| | |
|---------------------|-------|
| BV _{DSS} | 20V |
| I _D | 100mA |
| R _{DS(on)} | 3Ω |

Description

- Low voltage drive, 1.8V.
- Easy to use in parallel.
- High speed switching.
- ESD protected device.
- Pb-free package.

Symbol

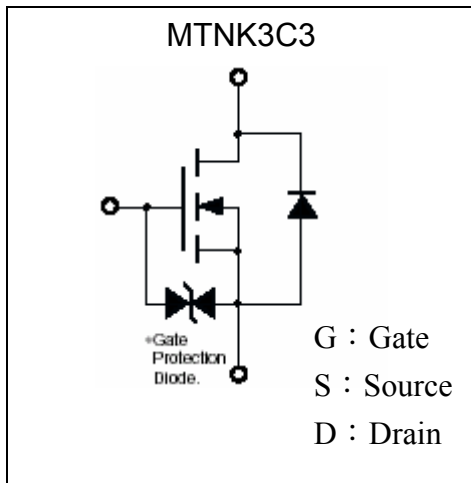

Outline

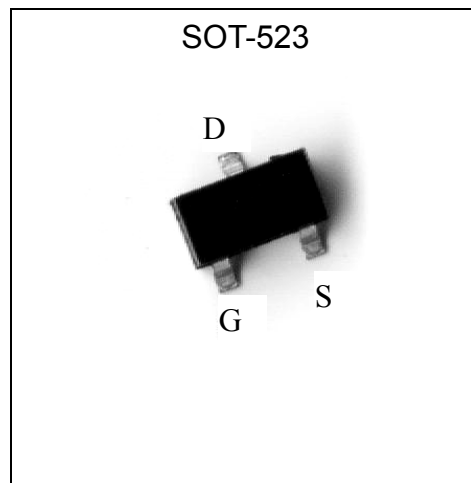

Absolute Maximum Ratings (Ta=25°C)

| Parameter | Symbol | Limits | Unit |
|--|--------------------|----------|------|
| Drain-Source Voltage | BV _{DSS} | 20 | V |
| Gate-Source Voltage | V _{GS} | ±8 | V |
| Continuous Drain Current | I _D | 100 | mA |
| Pulsed Drain Current | I _{DM} | 400 *1 | mA |
| Total Power Dissipation | P _D | 150 *2 | mW |
| ESD susceptibility | | 350 *3 | V |
| Operating Junction and Storage Temperature Range | T _j | -55~+150 | °C |
| Thermal Resistance, Junction-to-Ambient | R _{th,ja} | 833 | °C/W |

Note : *1. Pulse Width ≤ 300μs, Duty cycle ≤ 2%.
 *2. When device mounted on recommended land pattern.
 *3. Human body model, 1.5kΩ in series with 100pF.



Electrical Characteristics (Ta=25°C)

| Symbol | Min. | Typ. | Max. | Unit | Test Conditions |
|---------------------------|------|------|------|------|--|
| Static | | | | | |
| BV _{DSS} | 20 | - | - | V | V _{GS} =0, I _D =100μA |
| V _{GS(th)} | 0.5 | - | 1.0 | V | V _{DS} =V _{GS} , I _D =250μA |
| I _{GSS} | - | - | ±1 | μA | V _{GS} =±8V, V _{DS} =0 |
| I _{DSS} | - | - | 500 | nA | V _{DS} =20V, V _{GS} =0 |
| R _{DS(ON)} | - | 1.7 | 3 | Ω | V _{GS} =4.5V, I _D =100mA |
| | - | 3.5 | 6 | | V _{GS} =1.8V, I _D =20mA |
| G _{FS} | 100 | - | - | mS | V _{DS} =5V, I _D =100mA |
| Dynamic | | | | | |
| C _{iss} | - | 23 | 50 | pF | V _{DS} =10V, V _{GS} =0, f=1MHz |
| C _{oss} | - | 7.7 | 25 | | |
| C _{rss} | - | 5.8 | 5 | | |
| Source-Drain Diode | | | | | |
| *V _{SD} | - | - | 1 | V | V _{GS} =0V, I _S =10mA |

*Pulse Test : Pulse Width ≤300μs, Duty Cycle≤2%

Ordering Information

| Device | Package | Shipping | Marking |
|---------|----------------------|------------------------|---------|
| MTNK3C3 | SOT-523 (Pb-free) | 3000 pcs / Tape & Reel | K3 |

Typical Characteristics

Typical Output Characteristics

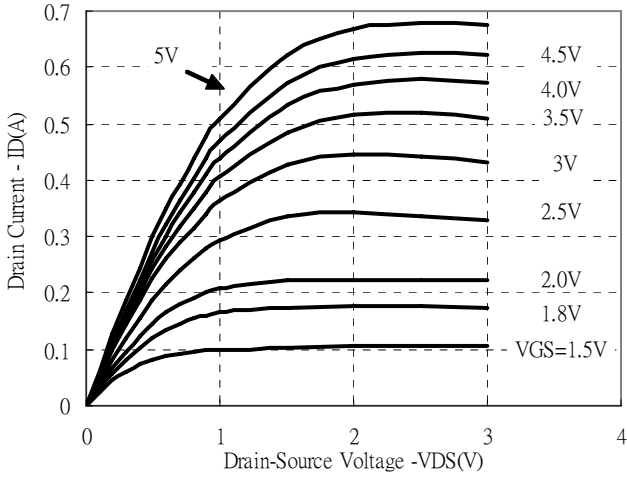

Typical Transfer Characteristics

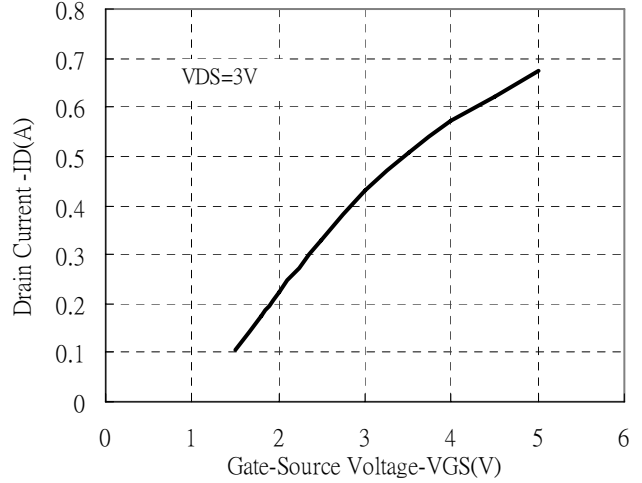

Static Drain-Source On-State resistance vs Drain Current

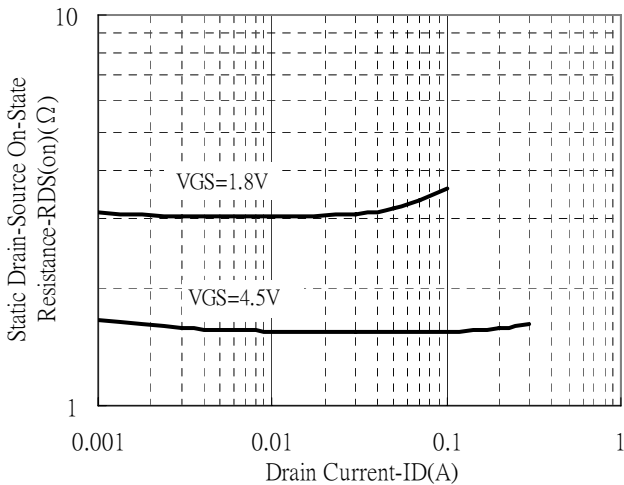

Static Drain-Source On-State Resistance vs Gate-Source Voltage

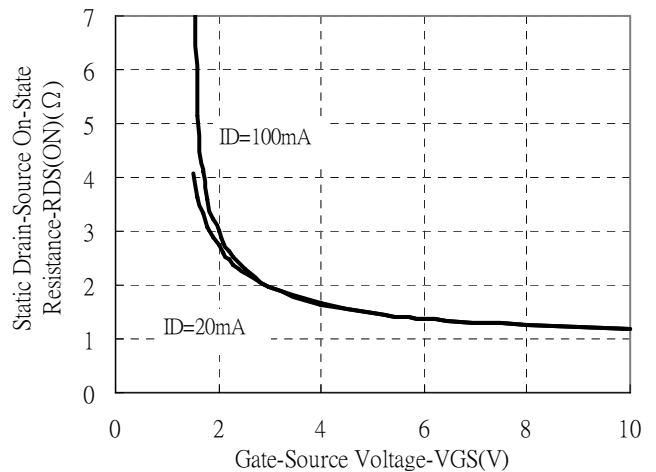

Reverse Drain Current vs Source-Drain Voltage

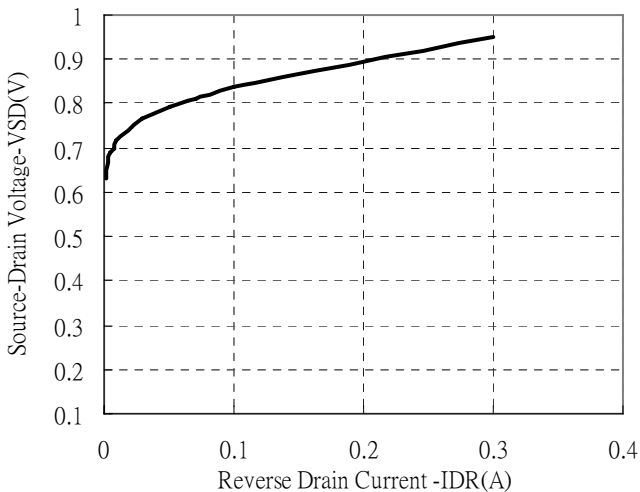

Capacitance vs Drain-to-Source Voltage

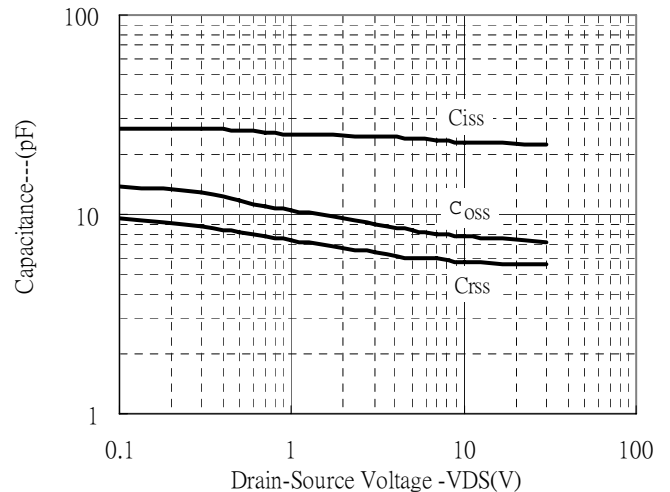

Reel Dimension

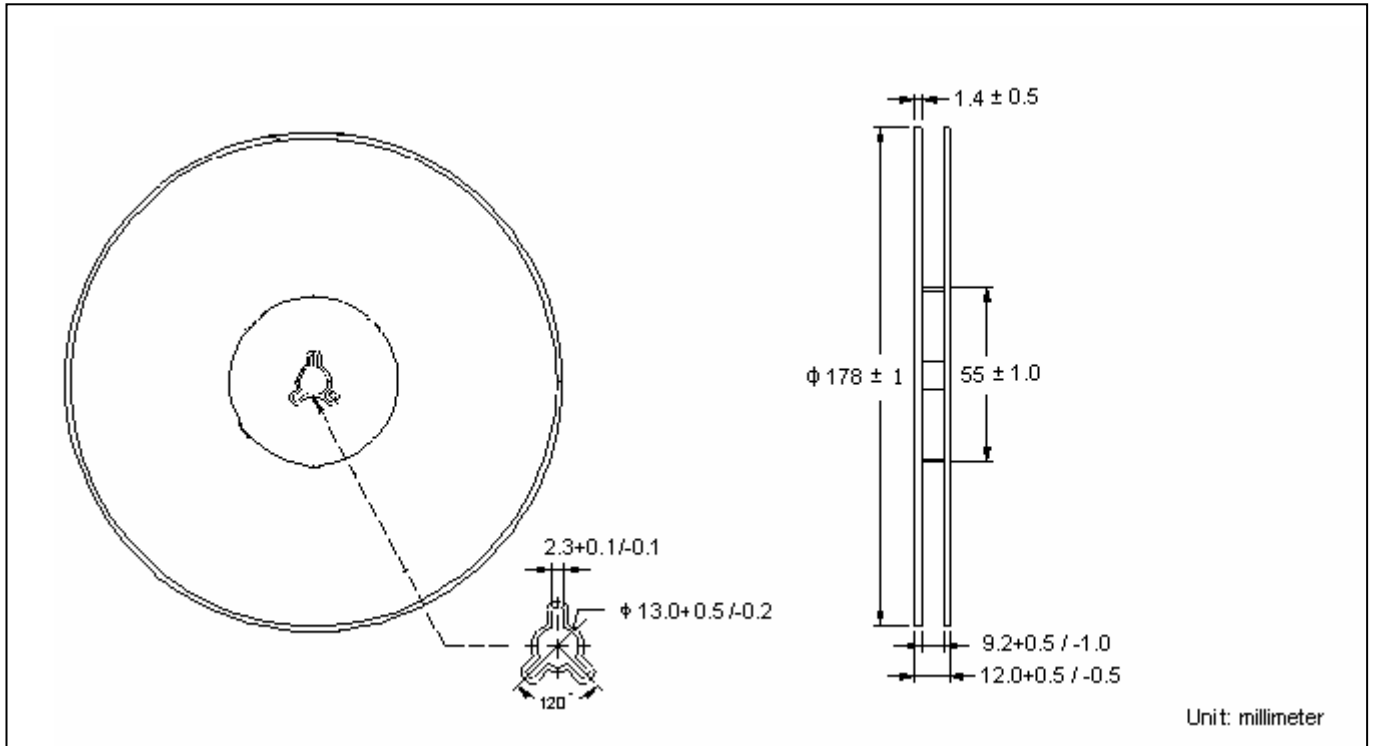

Carrier Tape Dimension

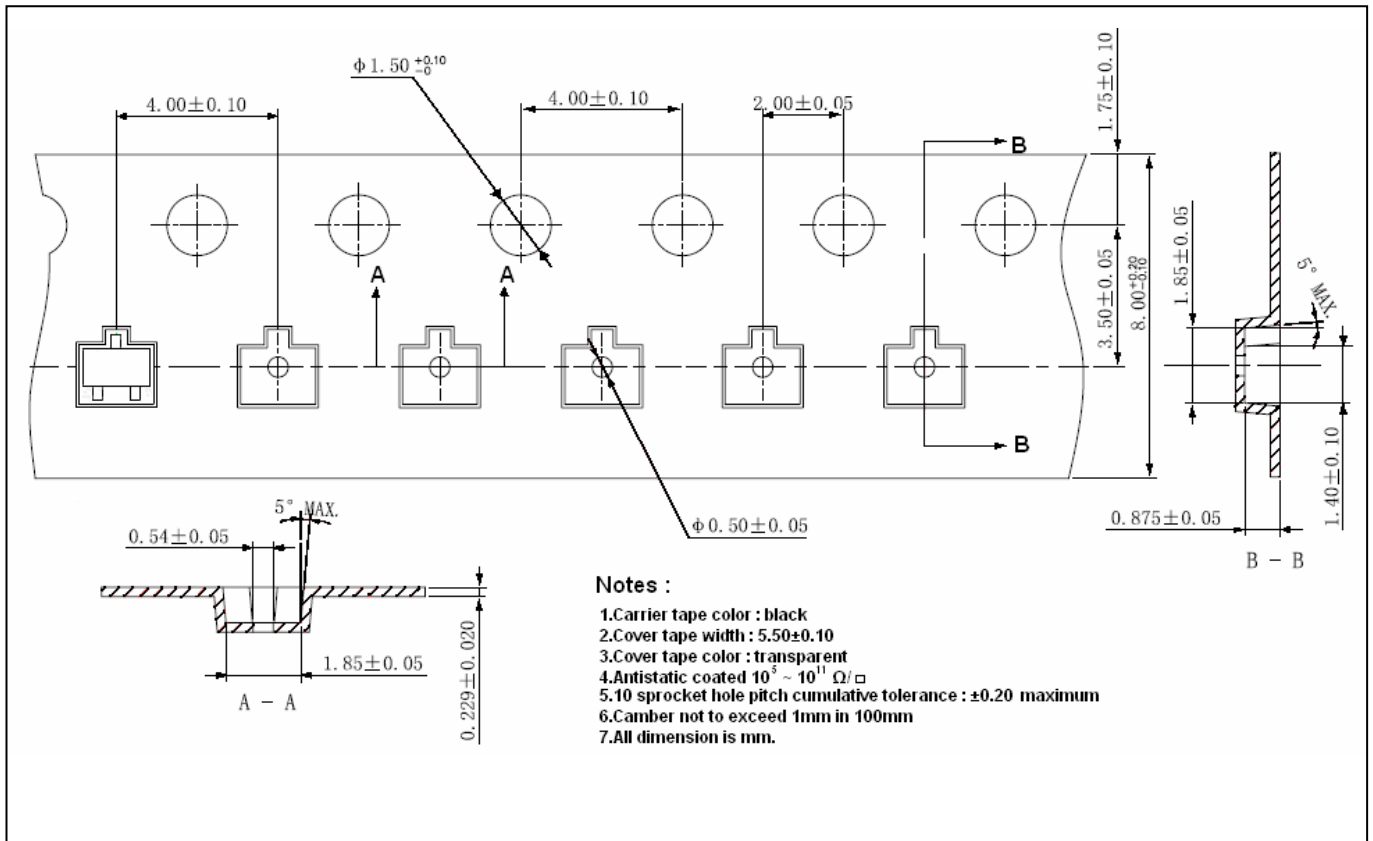

Recommended wave soldering condition

| | | |
|-----------------|------------------|-----------------|
| Product | Peak Temperature | Soldering Time |
| Pb-free devices | 260 +0/-5 °C | 5 +1/-1 seconds |

Recommended temperature profile for IR reflow

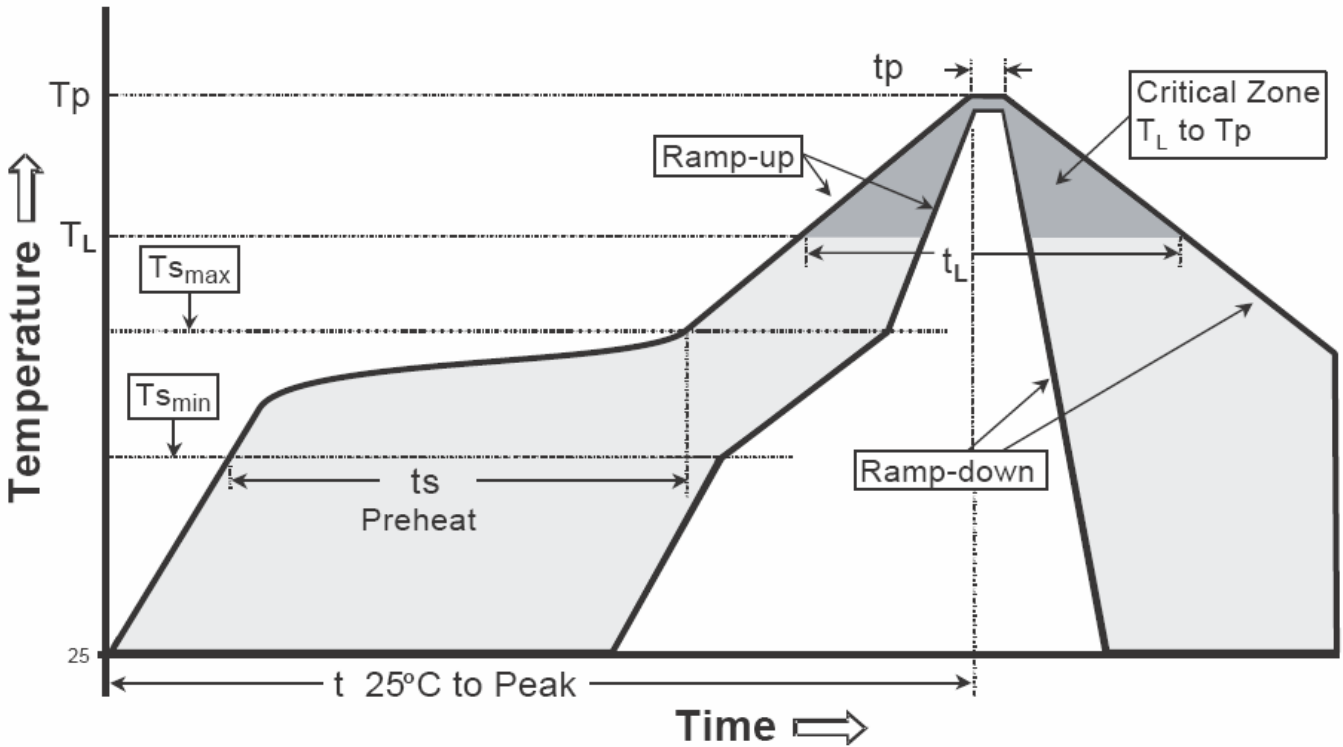

| Profile feature | Sn-Pb eutectic Assembly | Pb-free Assembly |
|---|-------------------------|------------------|
| Average ramp-up rate (T _{smax} to T _p) | 3°C/second max. | 3°C/second max. |
| Preheat | | |
| -Temperature Min(T _{s min}) | 100°C | 150°C |
| -Temperature Max(T _{s max}) | 150°C | 200°C |
| -Time($t_{s min}$ to $t_{s max}$) | 60-120 seconds | 60-180 seconds |
| Time maintained above: | | |
| -Temperature (T _L) | 183°C | 217°C |
| - Time (t _L) | 60-150 seconds | 60-150 seconds |
| Peak Temperature(T _P) | 240 +0/-5 °C | 260 +0/-5 °C |
| Time within 5°C of actual peak temperature(t_p) | 10-30 seconds | 20-40 seconds |
| Ramp down rate | 6°C/second max. | 6°C/second max. |
| Time 25 °C to peak temperature | 6 minutes max. | 8 minutes max. |

Note : All temperatures refer to topside of the package, measured on the package body surface.

SOT-523 Dimension

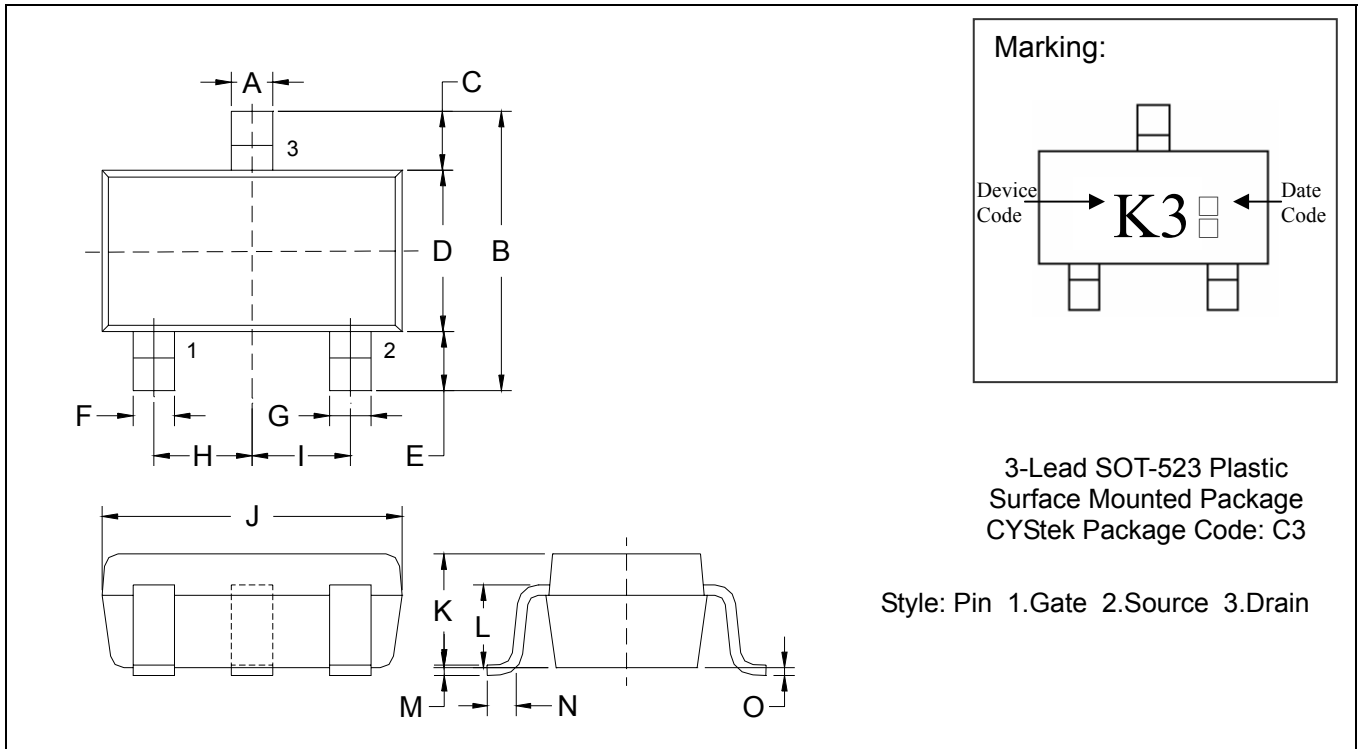

*: Typical

| DIM | Inches | | Millimeters | | DIM | Inches | | Millimeters | |
|-----|---------|--------|-------------|------|-----|---------|--------|-------------|------|
| | Min. | Max. | Min. | Max. | | Min. | Max. | Min. | Max. |
| A | 0.0079 | 0.0157 | 0.20 | 0.40 | I | *0.0197 | - | *0.50 | - |
| B | 0.0591 | 0.0669 | 1.50 | 1.70 | J | 0.0610 | 0.0650 | 1.55 | 1.65 |
| C | 0.0118 | 0.0197 | 0.30 | 0.50 | K | 0.0276 | 0.0315 | 0.70 | 0.80 |
| D | 0.0295 | 0.0335 | 0.75 | 0.85 | L | 0.0224 | 0.0248 | 0.57 | 0.63 |
| E | 0.0118 | 0.0197 | 0.30 | 0.50 | M | 0.0020 | 0.0059 | 0.05 | 0.15 |
| F | 0.0039 | 0.0118 | 0.10 | 0.30 | N | 0.0039 | 0.0118 | 0.10 | 0.30 |
| G | 0.0039 | 0.0118 | 0.10 | 0.30 | O | 0 | 0.0031 | 0 | 0.08 |
| H | *0.0197 | - | *0.50 | - | | | | | |

Notes: 1.Controlling dimension: millimeters.
 2.Maximum lead thickness includes lead finish thickness, and minimum lead thickness is the minimum thickness of base material.
 3.If there is any question with packing specification or packing method, please contact your local CYStek sales office.

Material:

- Lead: Pure tin plated.
- Mold Compound: Epoxy resin family, flammability solid burning class: UL94V-0

Important Notice:

- All rights are reserved. Reproduction in whole or in part is prohibited without the prior written approval of CYStek.
- CYStek reserves the right to make changes to its products without notice.
- CYStek **semiconductor products are not warranted to be suitable for use in Life-Support Applications, or systems.**
- CYStek assumes no liability for any consequence of customer product design, infringement of patents, or application assistance.