

MB05F – MB10F

0.8A SURFACE MOUNT GLASS PASSIVATED BRIDGE RECTIFIER

Formosa MS

Features

- Glass Passivated Die Construction
- Low Forward Voltage Drop
- High Current Capability
- High Surge Current Capability
- Designed for Surface Mount Application

Mechanical Data

- Case: MB-F, Molded Plastic
- Terminals: Plated Leads Solderable per MIL-STD-202, Method 208
- Polarity: As Marked on Case
- Weight: 0.082 grams (approx.)
- Mounting Position: Any
- Marking: Type Number
- **Lead Free: For RoHS / Lead Free Version,**

MBF

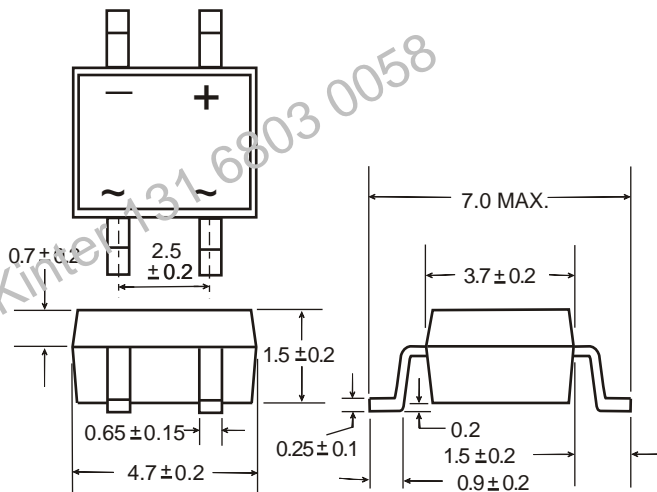

Dimensions in millimeters(1mm = 0.0394")

Maximum Ratings and Electrical Characteristics @T_A=25°C unless otherwise specified

Single Phase, half wave, 60Hz, resistive or inductive load.
For capacitive load, derate current by 20%.

Characteristic	Symbo	MB05F	MB1F	MB2F	MB4F	MB6F	MB8F	MB10F	Unit
Peak Repetitive Reverse Voltage	V _{RRM}	50	100	200	400	600	800	1000	V
Working Peak Reverse Voltage	V _{RWM}								
DC Blocking Voltage	V _R								
RMS Reverse Voltage	V _{R(RMS)}	35	70	140	280	420	560	700	V
Average Rectified Output Current (Note 1) @T _A = 40°C	I _o	0.5							A
Average Rectified Output Current (Note 2) @T _A = 40°C		0.8							
Non-Repetitive Peak Forward Surge Current 8.3ms Single half sine-wave superimposed on rated load (JEDEC Method)	I _{FSM}	30							A
I ² t Rating for Fusing (t < 8.3ms)	I ² t	5.0							A ² s
Forward Voltage per element @I _F = 0.5A	V _{FM}	1.0							V
@I _F = 0.8A		1.1							
Peak Reverse Current @T _A = 25°C	I _{RM}	5.0							μA
At Rated DC Blocking Voltage @T _A = 125°C		500							
Typical Junction Capacitance per leg (Note 3)	C _j	13							pF
Typical Thermal Resistance per leg (Note 1)	R _{θJA} R _{θJL}	60 16							°C/W
Operating and Storage Temperature Range	T _j , T _{STG}	-55 to +150							°C

Note: 1. Mounted on glass epoxy PC board with 1.3mm² solder pad.
2. Mounted on aluminum substrate PC board with 1.3mm² solder pad.
3. Measured at 1.0 MHz and applied reverse voltage of 4.0V D.C.



MB05F – MB10F

Formosa MS

Rating and Characteristic Curves

($T_A=25^{\circ}\text{C}$ Unless otherwise noted)

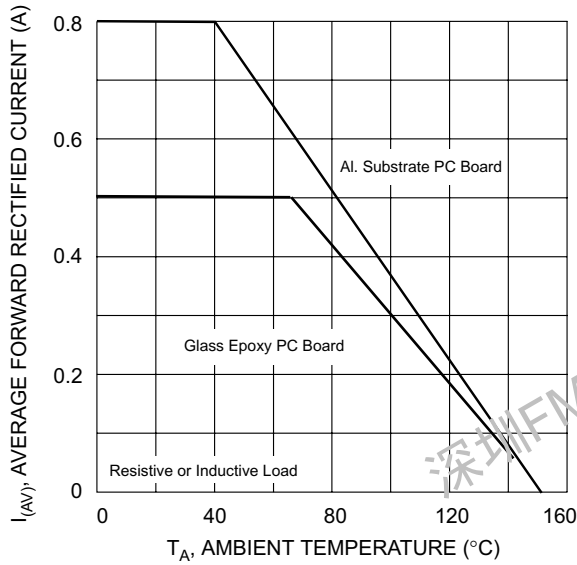

Fig. 1 Output Current Derating Curve

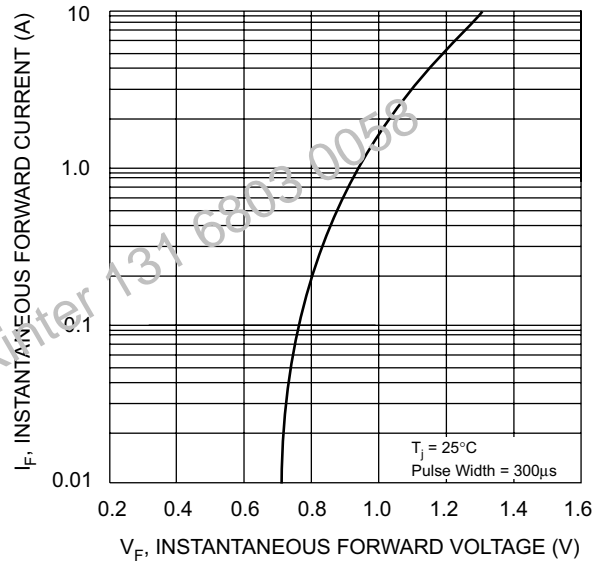

Fig. 2 Typical Forward Characteristics (per leg)

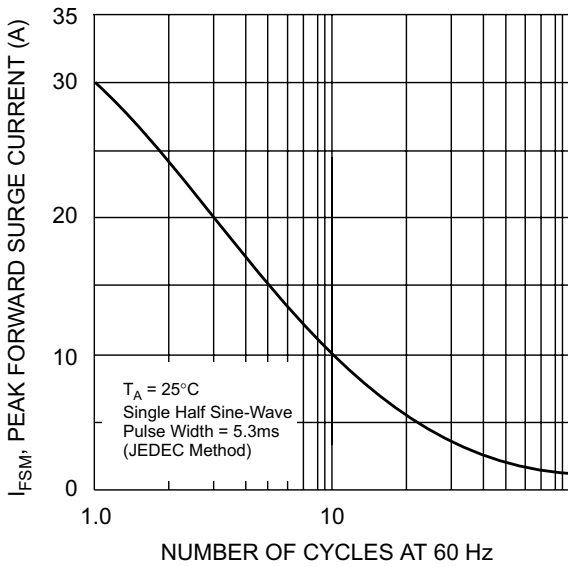

Fig. 3 Maximum Peak Forward Surge Current (per leg)

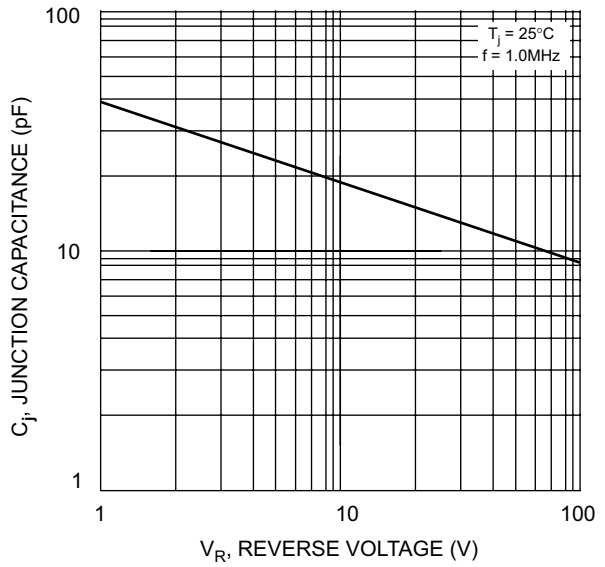

Fig. 4 Typical Junction Capacitance

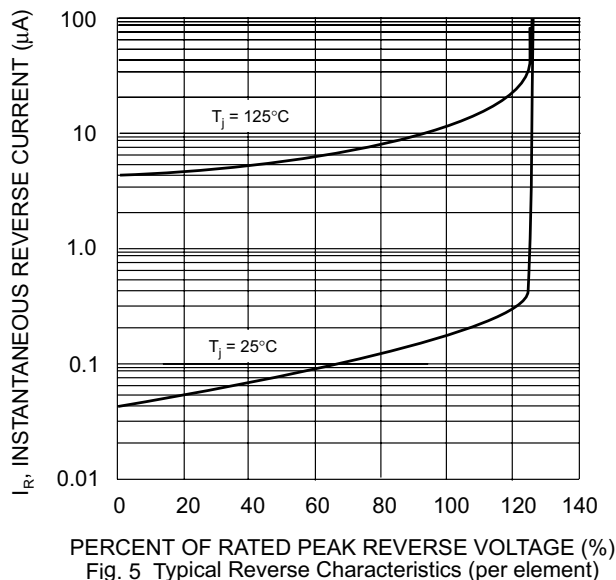

Fig. 5 Typical Reverse Characteristics (per element)

