

UL/CSA Fused Disconnect Switches

Switch (typical)	Amp Rating (A)	Maximum Horsepower ❶								Catalog Number	Price	Dimension Code
		1 Ø (60Hz)		Three Phase (60Hz)				DC				
		120V	240V	200V	240V	460V	600V	125V	250V			
UL Class J and CSA HRCI-J Fuses ❷												
	30	2	3	7.5	7.5	15	20	3	5	L10-NJ030P3	362	A1
	60	3	10	15	15	30	50	5	10	L10-NJ060P3	471	B1
	100	~	7.5	~	30	60	75	~	20	L10-NJ100P3	744	C1
	200	~	10	~	60	125	150	~	40	L10-NJ200P3	1641	D1
	400	~	~	100	125	250	300	~	50	L10-NJ400P3	3136	F1
CSA HRCII-C Fuses												
	30	2	3	7.5	7.5	15	20	~	~	L10-NA200P3	362	A1
	60	3	10	15	15	30	50	~	~	L10-NA300P3	471	B1
	100	~	15	25	30	60	75	~	~	L10-NH100P3	744	D1
	200	~	30	50	60	125	150	~	~	L10-NH200P3	1641	E1
	400	~	50	100	125	250	300	~	~	L10-NH400P3	3136	F1

UL/CSA Non-Fused Disconnect Switches ❸

Switch (typical)	Amp Rating (A)	Maximum Horsepower ❶								Catalog Number	Price	Dimension Code
		1 Ø (60Hz)		Three Phase (60Hz)				DC				
		120V	240V	200V	240V	460V	600V	125V	250V			
	30	2	3	7.5	7.5	15	20	3	5	L10-NN030P3	305	A2
	60	3	10	15	15	30	50	5	10	L10-NN060P3	414	B2
	100	~	7.5	~	30	60	75	~	20	L10-NN100P3	744	C1
	200	~	10	~	60	125	150	~	40	L10-NN200P3	1641	D1
	400	~	~	100	125	250	300	~	50	L10-NN400P3	3136	F1

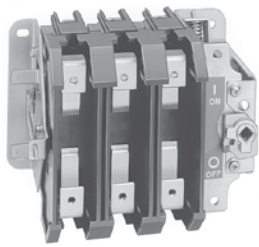
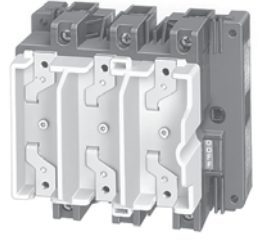
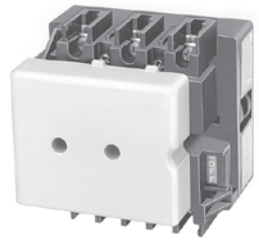



Note: L10 Fusible and Non-fusible Disconnect Switches with dimension codes D, E & F require lugs. Sprecher + Schuh lugs available on page L49.

Ordering Instructions

- Specify Disconnect Switch catalog number (page L46)
- Specify desired switch handle catalog number (page L47)
- Specify desired operating shaft catalog number (page L48)
- Specify desired accessories (page L49)





- ❶ Time delay fuses may be required to utilize the disconnect switch at its maximum horsepower rating.
- ❷ Only UL listed Class J and CSA Certified HRCI-J fuses are suitable for use with these disconnect switches.
- ❸ Non-fused disconnect switches must use separately installed UL Listed Class J, CC or T fuses or CSA Certified HRCI-J fuses.

Switch Handle Assemblies

Switch Handle Assembly ❶	Description	Color	Degree of Protection	Catalog Number	Price
 <p>Type R Handle with defeater</p> <p>76 x 76mm</p>	<p>Type R Handle - For 30A and 60A switches</p> <p>-With Defeater -Lockable: 3 locks ❷</p>	Black	Type 1 – IP42	L10-HS1	36
			Type 3R, 3, 12, 4, 4X – IP66	L10-HS4	56
		Red/Yellow	Type 1 – IP42	L10-HS1E	36
			Type 3R, 3, 12, 4, 4X – IP66	L10-HS4E	56
 <p>Type R Handle without defeater</p> <p>76 x 76mm</p>	<p>Type R Handle - For 30A and 60A switches</p> <p>-Without Defeater -Lockable: 3 locks ❷</p>	Black	Type 1 – IP42	L10-HS1-N2	68
			Type 3R, 3, 12, 4, 4X – IP66	L10-HS4-N2	56
		Red/Yellow	Type 1 – IP42	L10-HS1E-N2	68
			Type 3R, 3, 12, 4, 4X – IP66	L10-HS4E-N2	56
 <p>Pistol Grip Handle with defeater</p> <p>103 X 103mm</p>	<p>Pistol Grip Handle - For 100A, 200A and 400A switches ❸</p> <p>-With Defeater -Lockable: 3 locks ❷</p>	Black	Type 1 – IP42	L10-HM1	68
			Type 3R, 3, 12, 4, 4X – IP66	L10-HM4	104
		Red/Yellow	Type 1 – IP42	L10-HM1E	68
			Type 3R, 3, 12, 4, 4X – IP66	L10-HM4E	104
 <p>Pistol Grip Handle without defeater</p> <p>103 X 103mm</p>	<p>Pistol Grip Handle - For 100A, 200A and 400A switches ❸</p> <p>-Without Defeater -Lockable: 3 locks ❷</p>	Black	Type 1 – IP42	L10-HM1-N2	68
			Type 3R, 3, 12, 4, 4X – IP66	L10-HM4-N2	104
		Red/Yellow	Type 1 – IP42	L10-HM1E-N2	68
			Type 3R, 3, 12, 4, 4X – IP66	L10-HM4E-N2	104

❶ Mounting screws included with Switch Handle Assembly.
 ❷ Lockable in OFF position (and ON position with special modification).
 ❸ Can be used on 30 and 60A switches. Select L10-R1M or L10-R2M shaft.



Metal Operating Shafts

Shaft (typical)	Switch Dimension Code	For use with handle type...	Operating Shaft Length (mm)	Catalog Number	Price
	A1, A2 B1, B2	Type R (L10-30/60A)	263	L10-R1	22.75
			457	L10-R2	32.50
	A1, A2 B1, B2	Pistol Grip (L10-30/60A)	263	L10-R1M	34.00
			457	L10-R2M	45.50
	C1, D1	Pistol Grip (L10-100/200A)	200	L10-R3	27.50
			403	L10-R4	52.00
	E1, F1	Pistol Grip (L10-NH200/400A)	278	L10-R5	52.00
			532	L10-R6	97.50

Operating Shaft Accessories

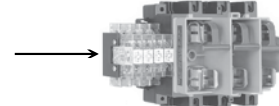

Accessory	Description	Catalog Number	Price
	Shaft Guide - Increases the alignment tolerance of the shaft to the switch handle. For L10-R1(2) shafts	L10-HSG1	6.50

Accessories

Accessory	Description	Catalog Number	Price
	Auxiliary Contact Blocks - One pole (NO) One pole (NC) Two pole (1 NO/1 NC) Two pole (NO) Two pole (NC)	L10-GA10 ①② L10-GA01 ①② L10-GA11 ①② L10-GA20 ①② L10-GA02 ①②	17.00 17.00 27.25 27.25 27.25
	Auxiliary Contact Adaptor - Required for fitting auxiliary contacts to all 30 & 60A fused and non-fused disconnect switches. One required.	L10-AA	8.00
	Auxiliary Contact Support Kit - Required when mounting more than two Auxiliary Contact Blocks per switch.	L10-A1	24.50

- ① 30 & 60A disconnect switches require Auxiliary Contact Adaptor (L10-AA) for installation of auxiliary contacts.
- ② A maximum of four contact blocks can be installed on each disconnect switch. When more than two contact blocks are used, the Auxiliary Contact Support Kit (L10-A1) must be installed.

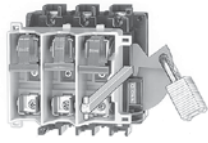
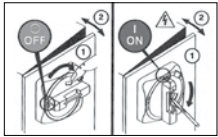
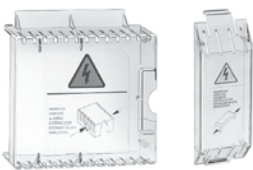
Accessories (Continued)

Accessory	Description	Catalog Number	Price	
	Padlocking Kit - For 30 & 60A switches	L10-P1	19.50	
	Switch Handle Instruction Label - For use with all Switch Handle Assemblies (10 per package - priced per package)	L10-L1	4.75	
	Fuse Covers ① -			
	Dim. Code	Quantity Req'd		
	A1, A2	1	L10-FCA2 ②	34.00
	B1, B2	1	L10-FCJ60 ②	40.50
	C1	3	L10-FCC1 ③	37.50
	D1	3	L10-FCD1	52.00
E1	3	L10-FCE1	71.50	
F1	3	L10-FCF1	97.50	
	Replacement Terminal Shield ②③ - All Disconnect Switches come standard with one Terminal Shield. For use on either line or load side of the disconnect switch.			
	Dim. Code			
	A1, A2	1	L10-LNC1 ②	13.00
	B1, B2	1	L10-LNC2 ②	22.75
	C1	3	L10-LNC3 ③	32.50
	D1	3	L10-LNC4	45.50
	E1	3	L10-LNC5	65.00
F1	3	L10-LNC6	84.50	
	Terminal Lugs - 3 per package			
	Dimension Code	Wire Size		
	D1 (L10-NH100P3 only)	10mm ² -50mm ² #8-1/0 AWG	L10-LE1	41.00
	D1	16mm ² -120mm ² #6-250MCM AWG	L10-LF1	92.75
	E1	25mm ² -240mm ² #4-500MCM AWG	L10-LG1	136.50
F1	Two 50mm ² -150mm ² Two 1/0-350MCM AWG	L10-LH1	197.00	



OBSOLETE

OBSOLETE

OBSOLETE

- ① Also used for covering the shorting bars on 100, 200 and 400A Non-fused Disconnect switches.
- ② 30...60A switches are supplied with line and load terminal shields, dead-front for non-fused disconnects, and fuse cover for fused disconnects. Terminal shields listed on this page are for renewal parts only.
- ③ 100...400A switches are supplied with line side lug (terminal) shields only. 100...400A switches do not include dead-front or fuse covers. Load side terminal and fuse covers must be ordered separately as required.

L10 Enclosed Motor Disconnects (UL and CSA Approved Enclosures)

Amp/Horsepower Rating								Type 3/4/12 Watertight, Dusttight Sheetmetal Enclosure - IP66			Type 4/4X Watertight, Corrosion-Resistant Stainless Steel Enclosure - IP66			Type 4/4X Watertight, Corrosion-Resistant Non-metallic Enclosure - IP66		
																
UL/ CSA Amps	Horsepower						Catalog Number	Price	Dimension Code	Catalog Number	Price	Dimension Code	Catalog Number	Price	Dimension Code	
	1Ø (60 Hz)			3Ø (60 Hz)												
	120V	240V	200V	240V	460V	600V										
Non-Fused																
30	2	3	7.5	7.5	15	20	L10-FN030P3	561	A2	L10-CN030P3	1056	A2	L10-KN030P3	561	A2	
60	3	10	15	15	30	50	L10-FN060P3	993	B2	L10-CN060P3	1337	B2	L10-KN060P3	993	B2	
100	~	7.5	~	30	60	75	L10-FN100P3	1433	C1	L10-CN100P3	2629	C1	L10-KN100P3	1433	C1	
200	~	10	~	60	125	150	L10-FN200P3	2390	D1	L10-CN200P3	3695	D1	L10-KN200P3	2389	D1	
400	~	~	100	125	250	300	L10-FN400P3	4402	F1	L10-CN400P3	7064	F1	L10-KN400P3	4401	F1	
Class J Fused																
30	2	3	7.5	7.5	15	20	L10-FJ030P3	847	A1	L10-CJ030P3	1217	A1	L10-KJ030P3	850	A1	
60	3	10	15	15	30	50	L10-FJ060P3	1053	B1	L10-CJ060P3	1398	B1	L10-KJ060P3	1053	B1	
100	~	7.5	~	30	60	75	L10-FJ100P3	1433	C1	L10-CJ100P3	2629	C1	L10-KJ100P3	1433	C1	
200	~	10	~	60	125	150	L10-FJ200P3	2390	D1	L10-CJ200P3	3695	D1	L10-KJ200P3	2389	D1	
400	~	~	100	125	250	300	L10-FJ400P3	4402	F1	L10-CJ400P3	7064	F1	L10-KJ400P3	4401	F1	

NOTE: All Enclosed Disconnects come standard with a black handle with ON/OFF marking. For a yellow and red handle, add suffix "E" to the end of the catalog number. Example: change L10-FN030P3 to L10-FN030P3E.

Fused Disconnect Switches for CSA HRCI-J and UL Class Fuses ①

		L10- NJ030P3		L10- NJ060P3		L10- NJ100P3		L10- NJ200P3		L10- NJ400P3		
Electrical Ratings												
Standards and Approvals (see page L32)												
CSA Fuse Type/UL Fuse Type		HRCI-J/ Class J		HRCI-J/ Class J		HRCI-J/ Class J		HRCI-J/ Class J		HRCI-J/ Class J		
Maximum Fuse Cartridge Size		[A] 30		60		100		200		400		
Maximum Voltage												
AC		[V] 600		600		600		600		600		
DC		[V] 250		250		250		250		250		
Ampere Rating		[A] 30		60		100		200		400		
Max. Short Circuit Prospective Fault Current		[kA] 100		100		100		100		100		
Fuse Operating Characteristics												
		Time Delay		Non-time Delay		Time Delay		Non-time Delay		Time Delay		Non-time Delay
Maximum HP												
3∅ AC 200V, 60Hz		[HP] 7.5		3		15		7.5		~		~
240V, 60Hz		[HP] 7.5		3		15		7.5		30		15
460V, 60Hz		[HP] 15		5		30		15		60		25
600V, 60Hz		[HP] 20		7.5		50		15		75		30
1∅ AC 120V, 60Hz		[HP] 2		0.5		3		1.5		~		~
240V, 60Hz		[HP] 3		1.5		10		3		7.5		7.5
DC 125V DC		[HP] 3		2		5		5		~		~
250V DC		[HP] 5		5		10		10		20		20
										40		40
										50		50
Mechanical Ratings												
Degree of Protection (per IEC 947)												
Switch only		IP00		Switch only		IP00		IP00		IP00		
Switch with Terminal Shields and Fuse Cover(s)		IP20		Switch with Terminal Shields and Fuse Cover(s)		IP20		IP20		IP20		
Mechanical Endurance ②		[operations] 10,000		10,000		10,000		8,000		8,000		
Handle Mechanism		[Nm] 4		4		17.5		20.3		31.4		
Operating Torque (max.)		[Lb.-In.] 35		35		155		180		275		
Terminal Capacity ③												
Power terminals		[mm²] 2.5...6		2.5...25		2.5...35		16...20		Two 50...150		
		[AWG] #14...#8		#14...#4		#14...#2		#6...250MCM		Two 1/0...350MCM		
Auxiliary contact terminals		[mm²] 2.5...4		2.5...4		2.5...4		2.5...4		2.5...4		
		[AWG] #14...#12		#14...#12		#14...#12		#14...#12		#14...#12		
Maximum number of auxiliary contact blocks		4		4		8		8		8		
Approximate Weight		[kg.] 0.92		1.32		4.12		6.16		13.83		
		[lbs.] 2.03		2.9		9.08		13.59		30.50		
Minimum Enclosure Size												
Height		[mm] 248		248		330		560		762		
		[in.] 9 3/4		9 3/4		13		22		30		
Width		[mm] 171		197		301		344		424		
		[in.] 6 3/4		7 3/4		11 27/32		13 17/32		16 45/64		
Depth		[mm] 148		148		162		178		243		
		[in.] 5 13/16		5 13/16		6 3/8		7		9 9/16		

① Only CSA Certified HRCI-J and UL Listed Class J fuses are suitable for use with these disconnect switches.

② Based on Rockwell Automation tests in accordance with the requirements as defined in CSA C22.2 No. 4, IEC 947-3, UL 1087 and UL98.

③ See L10 Power Wire Installation on page L58.1 for power terminal torque ratings.

Fused Disconnect Switches for CSA HRCII-C Fuses

		L10-NA200P3	L10-NA300P3	L10-NH100P3	L10-NH200P3	L10-NH400P3	
Electrical Ratings							
Standards and Approvals (see page L32)							
CSA Fuse Type		HRCII-C	HRCII-C	HRCII-C	HRCII-C	HRCII-C	
Maximum Fuse Cartridge Size	[A]	30	60	100	200	400	
Maximum Voltage - AC	[V]	600	600	600	600	600	
Ampere Rating	[A]	30	60	100	200	400	
Max. Short Circuit Prospective							
Fault Current	[kA]	100	100	100	100	100	
Maximum HP							
3∅ AC	200V, 60Hz	[HP]	7.5	15	25	50	100
	230V, 60Hz	[HP]	7.5	15	30	60	125
	460V, 60Hz	[HP]	15	30	60	125	250
	575V, 60Hz	[HP]	20	50	75	150	300
1∅ AC	115V, 60Hz	[HP]	2	3	–	–	–
	230V, 60Hz	[HP]	3	10	15	30	50
Mechanical Ratings							
Degree of Protection (per IEC 947)							
Switch only		IP00	IP00	IP00	IP00	IP00	
Switch with Terminal Shields and Fuse Cover(s)		IP20	IP20	IP20	IP20	IP20	
Mechanical Endurance ❶	[operations]	10,000	10,000	10,000	8,000	8,000	
Handle Mechanism	[Nm]	4	4	20.3	31.4	31.4	
Operating Torque (max.)	[Lb.-In.]	35	35	180	275	275	
Terminal Capacity ❷							
Power terminals	[mm²]	2.5...6	2.5...25	10...50	25...240	Two 50...150	
	[AWG]	#14...#8	#14...#4	#8...#1/0	#4...500MCM	Two 1/0...350MCM	
Auxiliary contact terminals	[mm²]	2.5...4	2.5...4	2.5...4	2.5...4	2.5...4	
	[AWG]	#14...#12	#14...#12	#14...#12	#14...#12	#14...#12	
Max. number of auxiliary contact blocks		4	4	4	4	4	
Approximate Weight		[kg.]	0.83	1.18	6.16	9.30	13.83
		[lbs.]	1.84	2.60	13.59	20.50	30.50
Minimum Enclosure Size							
Height	[mm]	248	248	384	610	762	
	[in.]	9 3/4	9 3/4	15 1/8	24	30	
Width	[mm]	171	197	344	394	424	
	[in.]	6 3/4	7 3/4	13 17/32	15 33/64	16 45/64	
Depth	[mm]	148	148	178	227	243	
	[in.]	5 13/16	5 13/16	7	8 15/16	9 9/16	

❶ Based on Sprecher+Schuh tests in accordance with the requirements as defined in CSA C22.2 No. 4 and IEC 947-3.
❷ See L10 Power Wire Installation on page L58.1 for power terminal torque ratings.

Non-Fused Disconnect Switches for CSA and UL Class Applications ①

		L10- NN030P3	L10- NN060P3	L10- NN100P3	L10- NN200P3	L10- NN400P3						
Electrical Ratings												
Standards and Approvals (see page L32)												
Maximum Fuse Cartridge Size	[A]	30 ②	60 ②	100 ②	200 ②	400 ②						
Maximum Voltage												
AC	[V]	600	600	600	600	600						
DC	[V]	250	250	250	250	250						
Ampere Rating	[A]	30	60	100	200	400						
Max. Short Circuit Prospective Fault Current	[kA]	100	100	100	100	100						
Fuse Operating Characteristics												
		Time	Non-time Delay	Time	Non-time Delay	Time	Non-time Delay	Time	Non-time Delay	Time	Non-time Delay	
Maximum HP												
3∅ AC	200V, 60Hz	[HP]	7.5	3	15	7.5	25	15	50	25	100	50
	230V, 60Hz	[HP]	7.5	3	15	7.5	30	15	60	25	125	50
	460V, 60Hz	[HP]	15	5	30	15	60	25	125	50	250	100
	575V, 60Hz	[HP]	20	7.5	50	15	75	30	150	60	300	125
1∅ AC	115V, 60Hz	[HP]	2	0.5	3	1.5	7.5	–	–	–	–	–
	230V, 60Hz	[HP]	3	1.5	10	3	15	7.5	25	15	50	25
DC	125V DC	[HP]	3	2	5	5	–	–	–	–	–	–
	250V DC	[HP]	5	5	10	10	20	20	40	40	50	50
Mechanical Ratings												
Degree of Protection (per IEC 947)												
Switch only			IP20	IP20	IP00	IP00	IP00					
Switch with Terminal Shields and Fuse Cover(s)			IP20 ④	IP20 ④	IP20	IP20	IP20					
Mechanical Endurance ⑤	[operations]	10,000	10,000	10,000	8,000	8,000						
Handle Mechanism Operating Torque (max.)	[Nm]	4	4	17.5	20.3	31.4						
	[Lb.-In.]	35	35	155	180	275						
Terminal Capacity ⑥												
Power terminals	[mm²]	2.5...6	2.5...25	2.5...35	16...120	Two 50...150						
	[AWG]	#14...#8	#14...#4	#14...#2	#6...250MCM	Two 1/0...350MCM						
Auxiliary contact terminals	[mm²]	2.5...4	2.5...4	2.5...4	2.5...4	2.5...4						
	[AWG]	#14...#12	#14...#12	#14...#12	#14...#12	#14...#12						
Max. number of auxiliary contact blocks		4	4	4	4	4						
Approximate Weight	[kg.]	0.81	1.14	4.31	6.56	14.97						
	[lbs.]	1.78	2.52	9.50	14.47	33.00						
Minimum Enclosure Size												
Height	[mm]	248	248	330	560	762						
	[in.]	9 3/4	9 3/4	13	22	30						
Width	[mm]	171	197	301	344	424						
	[in.]	6 3/4	7 3/4	11 27/32	13 17/32	16 45/64						
Depth	[mm]	111	111	162	178	243						
	[in.]	4 3/8	4 3/8	6 3/8	7	9 9/16						

① Non-fused disconnects must use separately installed CSA Certified HRCI-J, HRCI-T or HRCI-MISC (also UL Listed as Class CC) fuses; or UL Listed Class J, CC or T fuses.
 ② When using CSA HRCI-J, HRCI-MISC (also UL Listed as Class CC) or HRCI-T fuses, and UL Class J, CC or T fuses.

③ Based on Sprecher + Schuh tests in accordance with the requirements as defined in CSA C22.2 No. 4, IEC 947-3, UL 1087 and UL98.
 ④ Line and load terminal shields supplied as standard.
 ⑤ See L10 Power Wire Installation on page L58.1 for power terminal torque ratings.

L10 Disconnect Switch (30 & 60A)

Dimensions are in millimeters (inches). Dimensions not intended for manufacturing purposes.

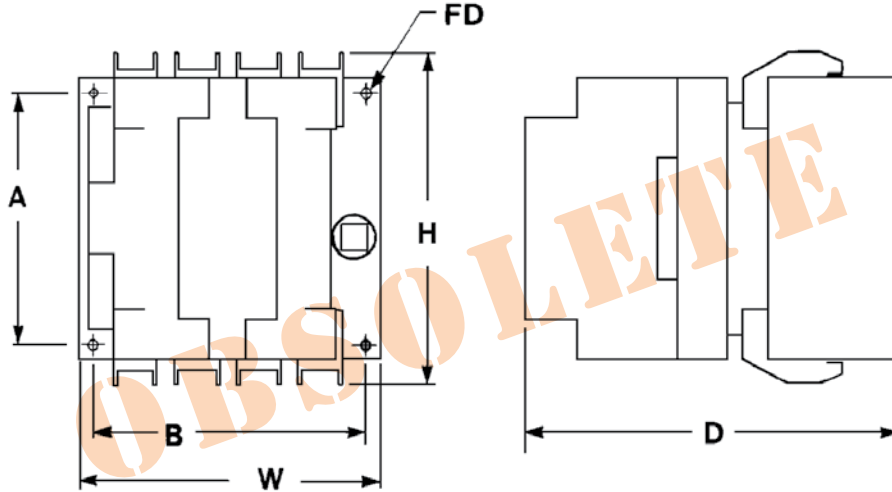

Disconnect Switch	Approximate Dimensions					
Dimension Reference	H	W	D	A	B	FD
A1	106 (4 11/64)	102 (4 1/64)	112 (4 13/32)	82 (3 15/64)	85 (3 11/32)	2-M4 2-#8
A2	106 (4 11/64)	102 (4 1/64)	83 (3 17/64)	82 (3 15/64)	82 (3 15/64)	2-M4 2-#8
B1	118 (4 21/32)	134 (5 9/32)	115 (4 33/64)	100 (3 15/16)	120 (4 23/32)	4-M4 4-#8
B2	118 (4 21/32)	134 (5 9/32)	83 (3 17/64)	100 (3 15/16)	120 (4 23/32)	4-M4 4-#8

L10 Disconnect Switch (100, 200 & 400A)

Dimensions are in millimeters (inches). Dimensions not intended for manufacturing purposes.

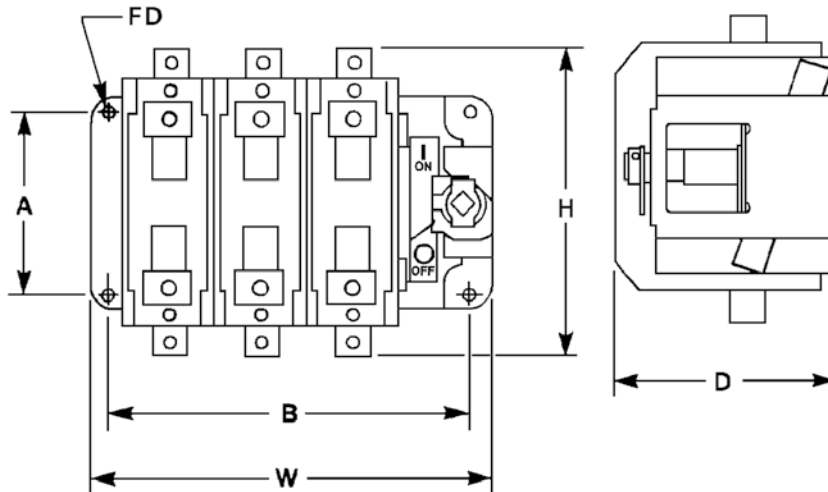

Disconnect Switch	Approximate Dimensions					
Dimension Reference	H	W	D	A	B	FD
C1	148 (5 53/64)	194 (7 41/64)	130 (5 7/64)	106 (4 11/64)	170 (6 11/16)	4-M6 (4 1/4)
D1	184 (7 1/4)	236 (9 19/64)	148 (5 53/64)	106 (4 11/64)	212 (8 11/32)	4-M6 (4 1/4)
E1	220 (8 21/32)	278 (10 15/16)	180 (7 3/32)	150 (5 29/32)	252 (9 59/64)	4-M8 (4 5/16)
F1	250 (9 27/32)	308 (12 1/8)	213 (8 25/64)	150 (5 29/32)	282 (11 7/64)	4-M8 (4 5/16)

L10 Power Wire Installation

Dimensions are in millimeters (inches). Dimensions not intended for manufacturing purposes.

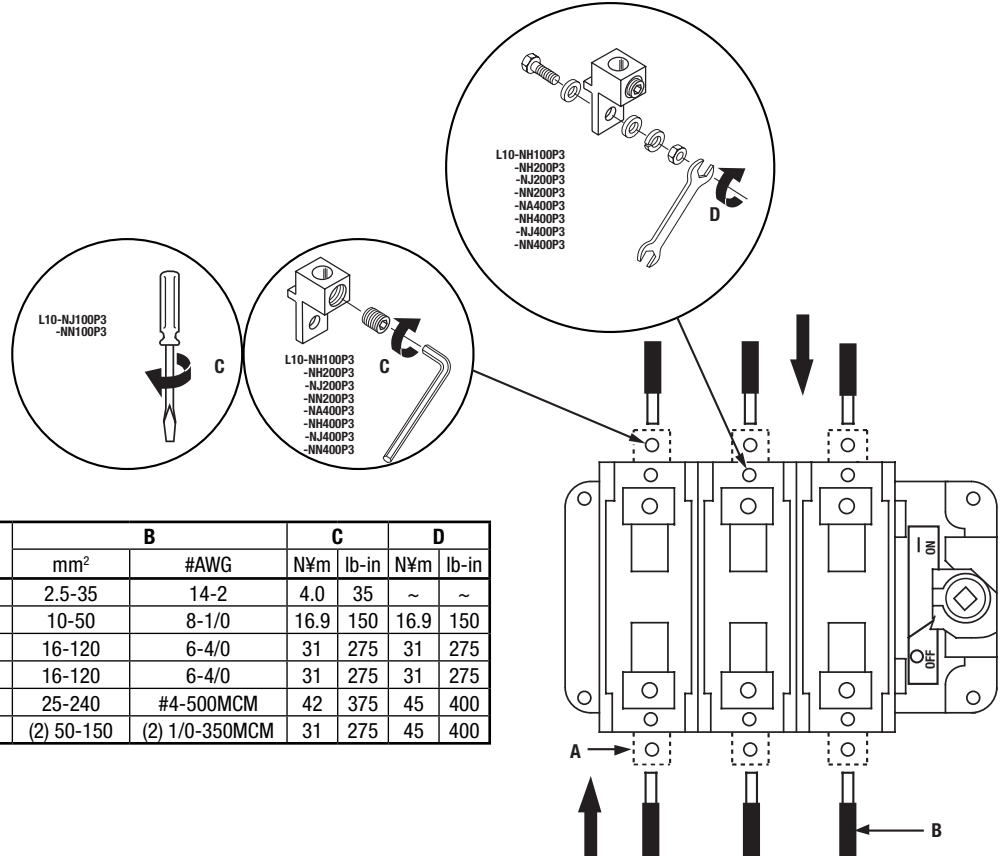

Dimension Reference	A	B		C		D	
		mm ²	#AWG	N¥m	lb-in	N¥m	lb-in
C1, C2	L10-LE1	2.5-35	14-2	4.0	35	~	~
D1	L10-LF1	10-50	8-1/0	16.9	150	16.9	150
	L10-LF1	16-120	6-4/0	31	275	31	275
D2	L10-LF1	16-120	6-4/0	31	275	31	275
E1	L10-LG1	25-240	#4-500MCM	42	375	45	400
F1	L10-LH1	(2) 50-150	(2) 1/0-350MCM	31	275	45	400

L10 Fuse Installation

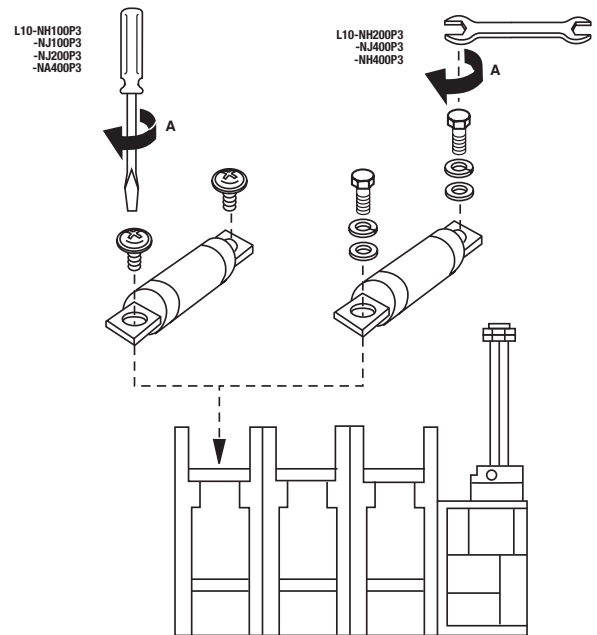

Catalog Number	A	
	N¥m	lb-in
L10-NJ100P3	4.0	35
L10-NJ200P3	4.0	35
L10-NH100P3	6.2	55
L10-NA400P3	6.2	55
L10-NH200P3	16	140
L10-NH400P3	16	140
L10-NJ400P3	22	200

L10-HS... (Type R) Switch Handle Assembly

Dimensions are in millimeters (inches). Dimensions not intended for manufacturing purposes.

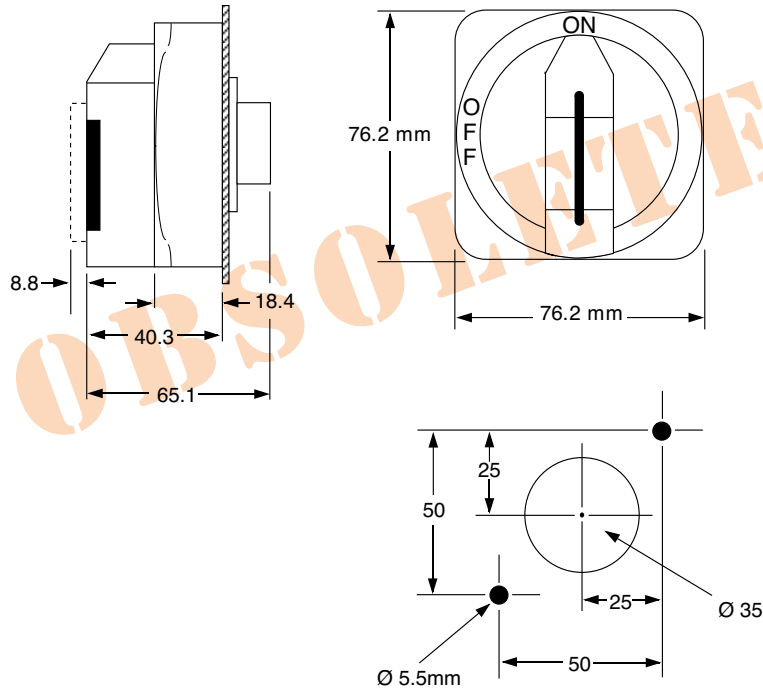

L10-HM... Pistol Grip Switch Handle Assembly

Dimensions are in millimeters (inches). Dimensions not intended for manufacturing purposes.

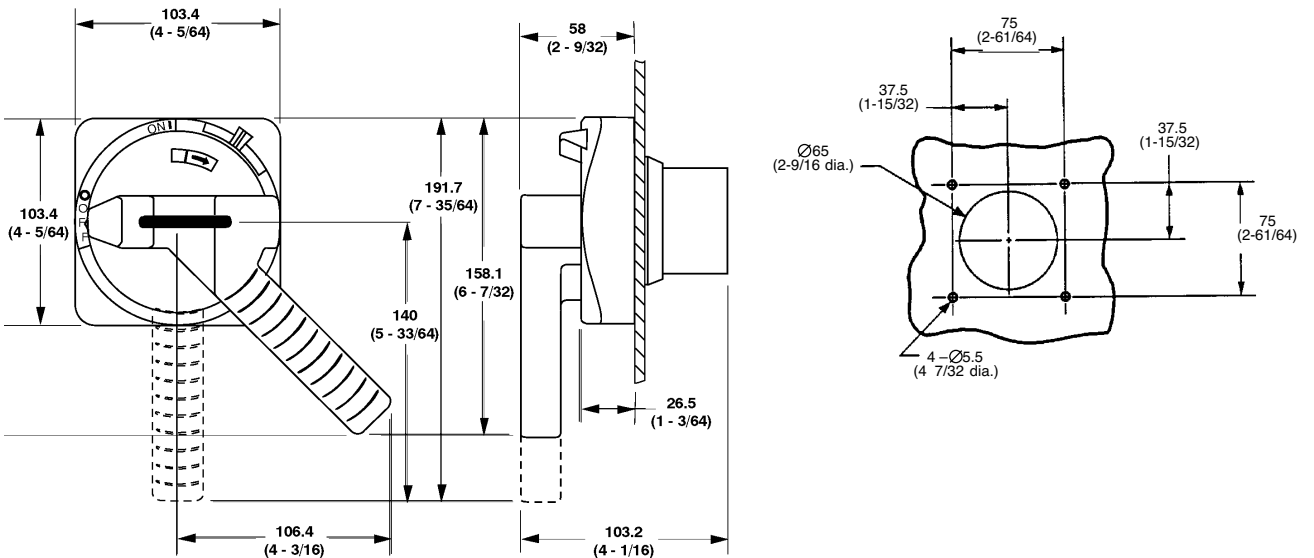

Type 3/4/12 - Watertight, Dusttight Sheet Metal Enclosure (30, 60 & 100A)

Dimensions are in millimeters (inches). Dimensions not intended for manufacturing purposes.

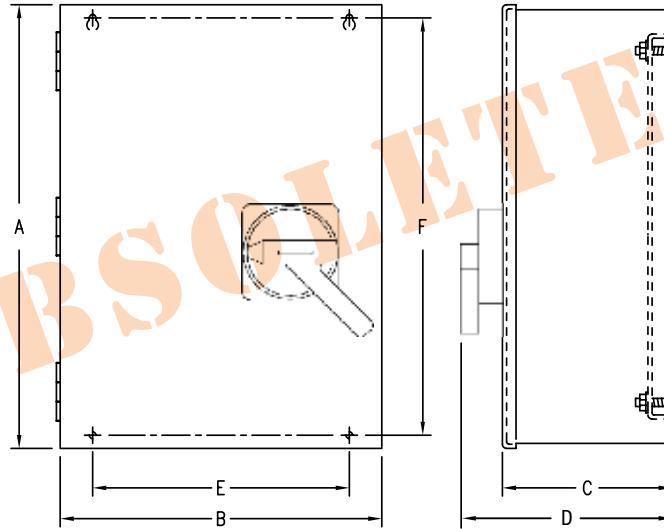

Amps	Type	Dim. Ref.	A	B	C	D	E	F	G	H
30	Fused &	A1, A2	305	305	173	213	267	267	76	265
	Non-fused		(12.00)	(12.00)	(6.80)	(8.39)	(10.5)	(10.5)	(3)	(10-7/16)
60	Fused &	B1, B2	305	305	173	213	267	267	76	265
	Non-fused		(12.00)	(12.00)	(6.80)	(8.39)	(10.5)	(10.5)	(3)	(10-7/16)
100	Fused &	C1	406	406	224	282	368	368	178	315
	Non-fused		(16.00)	(16.00)	(8.80)	(11.10)	(14.5)	(14.5)	(7)	(12-25/64)

Type 3/4/12 - Watertight, Dusttight Sheet Metal Enclosure (200 & 400A)

Dimensions are in millimeters (inches). Dimensions not intended for manufacturing purposes.

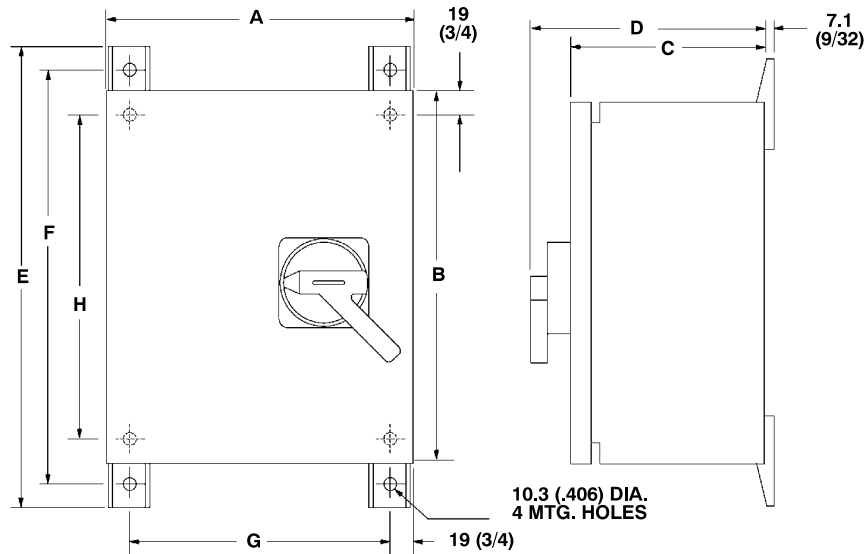

Amps	Type	Dim. Ref.	A	B	C	D	E	F	G	H
200	Fused &	D1	406	610	224	282	688	650	368	572
	Non-Fused		(16)	(24)	(8-51/64)	(11-5/64)	(27-5/64)	(25-9/16)	(13-31/64)	(22-1/2)
400	Fused &	F1	610	762	326	384	840	802	572	724
	Non-Fused		(24)	(30)	(12-51/64)	(15-5/64)	(33-5/64)	(31-9/16)	(22-1/2)	(28-1/2)

Type 4/4X Watertight, Corrosion-Resistant Stainless Steel Enclosure (30, 60 & 100A)

Dimensions are in millimeters (inches). Dimensions not intended for manufacturing purposes.

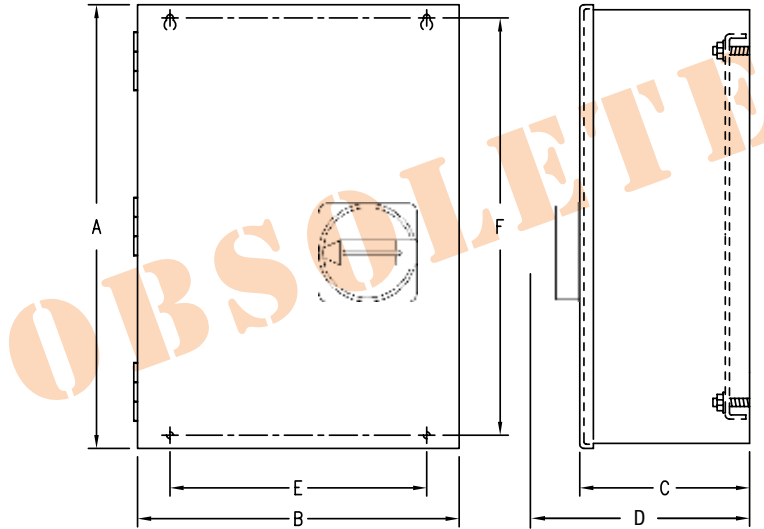

Amps	Type	Dim. Ref.	A	B	C	D	E	F	G	H
30	Fused & Non-fused	A1, A2	305 (12.00)	305 (12.00)	173 (6.80)	213 (8.39)	267 (10.5)	267 (10.5)	76 (3)	265 (10-7/16)
60	Fused & Non-fused	B1, B2	305 (12.00)	305 (12.00)	173 (6.80)	213 (8.39)	267 (10.5)	267 (10.5)	76 (3)	265 (10-7/16)
100	Fused & Non-fused	C1	406 (16.00)	406 (16.00)	224 (8.80)	282 (11.10)	368 (14.5)	368 (14.5)	178 (7)	315 (12-25/64)

Type 4/4X Watertight, Corrosion-Resistant Stainless Steel Enclosure (200 & 400A)

Dimensions are in millimeters (inches). Dimensions not intended for manufacturing purposes.

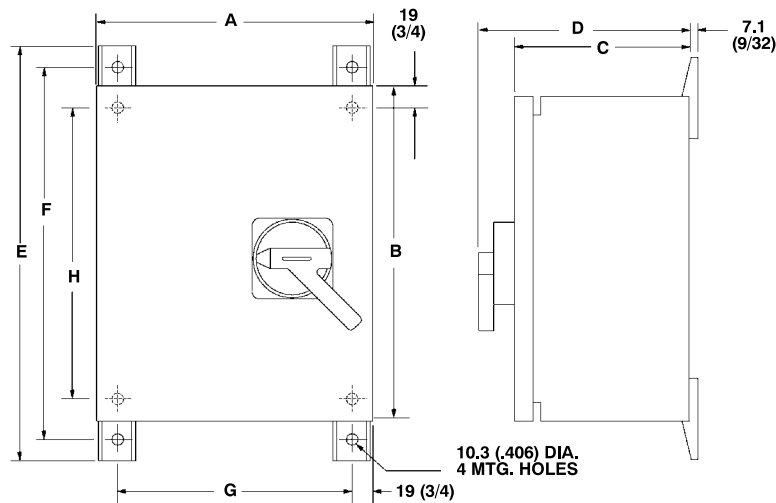

Amps	Type	Dim. Ref.	A	B	C	D	E	F	G	H
200	Fused & Non-Fused	D1	406 (16)	610 (24)	224 (8-51/64)	282 (11-5/64)	688 (27-5/64)	650 (25-19/32)	368 (14-1/2)	572 (22-1/2)
400	Fused & Non-Fused	F1	610 (24)	762 (30)	326 (12-51/64)	384 (15-5/64)	840 (33-5/64)	802 (31-15/32)	572 (22-1/2)	724 (28-1/2)

Type 3/4/4X/12 - Corrosion Resistant Non-Metallic Enclosure (30 & 60A)

Dimensions are in millimeters (inches). Dimensions not intended for manufacturing purposes.

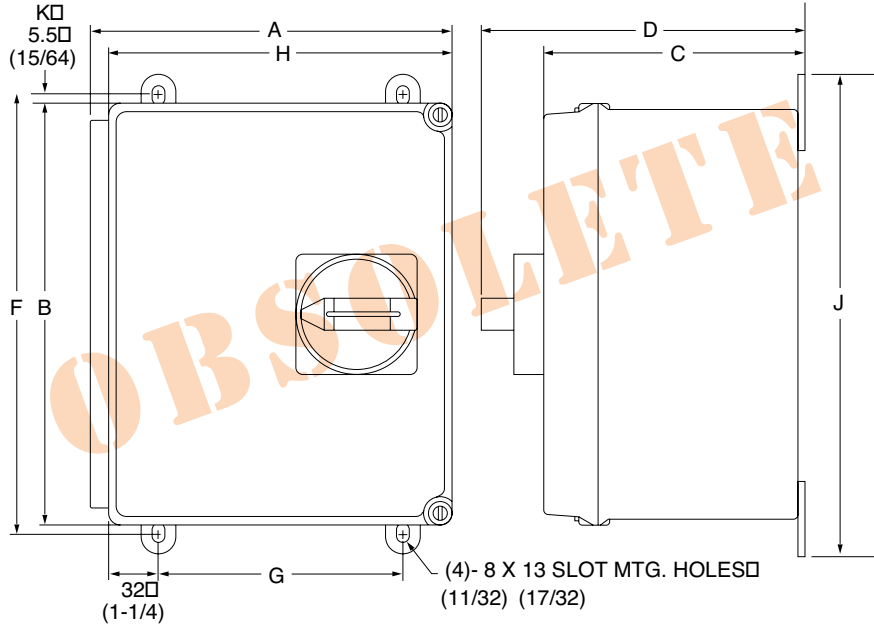

Amps	Type	Dim. Ref.	A	B	C	D	F	G	H	J	K
30 & 60	Fused & Non-Fused	A1 & A2 B1 & B2	226 (8-59/64)	267 (10-33/64)	163 (6-27/64)	203 (7-31/32)	278 (10-61/64)	152 (6)	216 (8-1/2)	305 (12)	6 (15/64)

Type 3/4/4X/12 - Corrosion Resistant Non-Metallic Enclosure (100A)

Dimensions are in millimeters (inches). Dimensions not intended for manufacturing purposes.

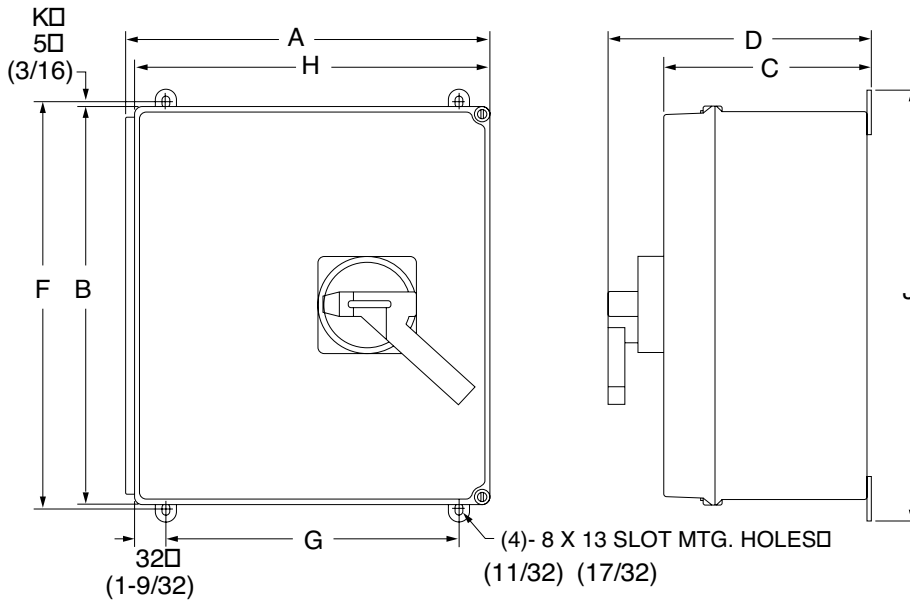

Amps	Type	Dim. Ref.	A	B	C	D	F	G	H	J	K
100	Fused & Non-Fused	C1	380 (14-31/32)	420 (16-1/4)	215 (8-31/64)	273 (10-49/64)	430 (16-61/64)	305 (12)	370 (14-9/16)	457 (18)	5 (13/64)