



TS5201

200mA Low Noise LDO Voltage Regulator with Enable

SOP-8



Pin assignment

- | | |
|-------------|-----------|
| 1. Output | 5. Enable |
| 2. ADJ / NC | 6. NC |
| 3. Ground | 7. NC |
| 4. NC | 8. Input |

- Low Power Consumption**
- Low Dropout Voltage 0.275V**
- Fixed and Adjustable Output**
- Enable Shutdown**

General Description

The TS5201 series is an efficient linear voltage regulator with ultra low noise output, very low dropout voltage (typically 17mV at light loads and 165mV at 200mA), and very low power consumption (600uA at 100mA), providing high output current even when the application requires very low dropout voltage. The Chip Enable (CE) includes a CMOS or TTL compatible input allows the output to be turned off to prolong battery life. When shutdown, power consumption drops nearly to zero.

The TS5201 series is included a precision voltage reference, error correction circuit, a current limited output driver, over temperature shutdown, reversed battery protection and a reference bypass pin to improve its already excellent low-noise performance.

The TS5201 series is available in fixed and adjustable output voltage version in SOP-8 package.

Features

- ✧ Ultra low noise output.
- ✧ Output current up to 200mA
- ✧ Low dropout voltage
- ✧ Low power consumption
- ✧ "Zero" off-mode current
- ✧ Logic controlled electronic enable
- ✧ Internal current limit and Thermal shutdown protection

Ordering Information

Part No.	Operating Temp.	Package
TS5201CSxx	0 ~ +125 °C	SOP-8

Note: Where **xx** denotes voltage option, available are 5.0V, 3.3V, 3.0V and 2.5V. Leave blank for adjustable version. Contact factory for additional voltage options.

Applications

- ✧ Cellular telephones
- ✧ Palmtops, notebook computers
- ✧ Battery powered equipment
- ✧ Consumer and personal electronics
- ✧ SMPS post regulator and DC to DC modules
- ✧ High-efficiency linear power supplies

Typical Application Circuit

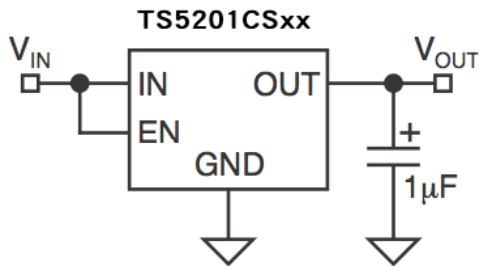

Fixed Application

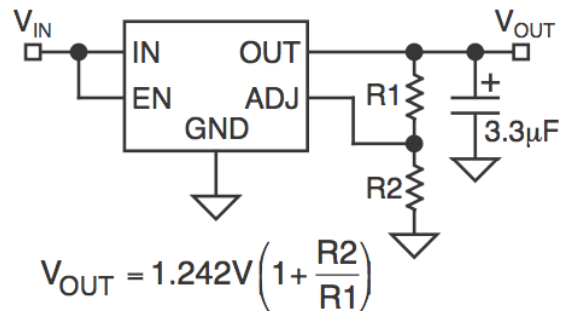

Adjustable Application



Absolute Maximum Rating (Note 1)						
Input Supply Voltage	Vin		-20~ +20		V	
Enable Input Voltage	Vce		-20~ +20		V	
Power Dissipation (Note 2)	PD		Internal limited			
Thermal Resistance	Θja		220		°C/W	
Operating Junction Temperature Range	Tj		0 ~ +125		°C	
Storage Temperature Range	TSTG		-65 ~ +150		°C	
Lead Soldering Temperature (260 °C)			5		S	
Recommend Operating Rating (Note 3)						
Input Supply Voltage	Vin		+2.5 ~ +16		V	
Enable Input Voltage	Vce		0 ~ Vin		V	
Electrical Characteristics						
Vin=Vo+1V, Io=100uA, Cout=1uF, Vce≥2V, Tj = 25 °C, unless otherwise specified.						
Parameter	Conditions	Min	Typ	Max	Unit	
Output Voltage	Vin=Vo + 1V	0.99 Vo	Vout	1.01 Vo	V	
Output Voltage Temp. Coefficient	(Note 4)	--	40	--	ppm/°C	
Line Regulation	Vo+1V ≤ Vin ≤ 16V	--	0.005	0.05	%/V	
Load Regulation (Note 5)	0.1mA ≤ Io ≤ 200mA	--	0.02	0.2	%/V	
Dropout Voltage (Note 6)	Io=100uA	--	17	50	mV	
	Io=50mA	--	110	150		
	Io=100mA	--	140	250		
	Io=200mA	--	165	275		
Quiescent Current	Vin≤0.4V (shutdown)	--	0.01	1	uA	
	Vin≤0.18V (shutdown)	--	--	5		
Ground Pin Current (Note 7)	Vce≥2V	Io=100uA	--	80	125	uA
		Io=50mA	--	350	600	
		Io=100mA	--	600	1000	
		Io=200mA	--	1300	1900	
Output Current Limit	Vout=0V	--	300	500	mA	
Power Supply Rejection Ratio	At f=100Hz, Io=100uA,	--	75	--	dB	
Thermal Regulation (Note 8)		--	0.05	--	%/W	
Output Noise	Io=50mA, Cout=2.2uF, 470pF from bypass to Ground	--	260	--	nV	
Enable function						
Enable Input Logic-Low Voltage	Regulation shutdown	--	--	0.4	V	
Enable Input Logic-High Voltage	Regulation enable	2.0	--	--	V	
Enable Input Current	VIL≤ 0.4V	--	0.01	-1	uA	
	VIH≥ 2.0V	--	5	20		

Electrical Characteristics (continued)

Note 1: Exceeding the absolute maximum rating may damage the device.

Note 2: The maximum allowable power dissipation at any T_a is $P_d(\max) = [T_j(\max) - T_a] + \Theta_{ja}$. Exceeding the maximum allowable power dissipation will result in excessive die temperature, and the regulator will go into thermal shutdown.

Note 3: The device is not guaranteed to function outside its operating rating.

Note 4: Output voltage temperature coefficient is defined as the worst case voltage change divided by the total temperature range.

Note 5: Regulation is measured at constant junction temperature using low duty cycle pulse testing. Parts are tested for load regulation in the load range from 1mA to 200mA. Changes in output voltage due to heating effects are covered by the thermal regulation specification.

Note 6: Dropout voltage is defined as the input to output differential at which the output voltage drops 2% below its nominal value measured at 1V differential.

Note 7: Ground pin current is the regulator quiescent current plus pass transistor base current. The total current drawn from the supply is the sum of the load current plus the ground pin current.

Note 8: Thermal regulation is defined as the change in output voltage at a time "t" after a change in power dissipation is applied, excluding load or line regulation effects. Specifications are for a 200mA load pulse at $V_{in}=16V$ for $t=10mS$.

Block Diagrams

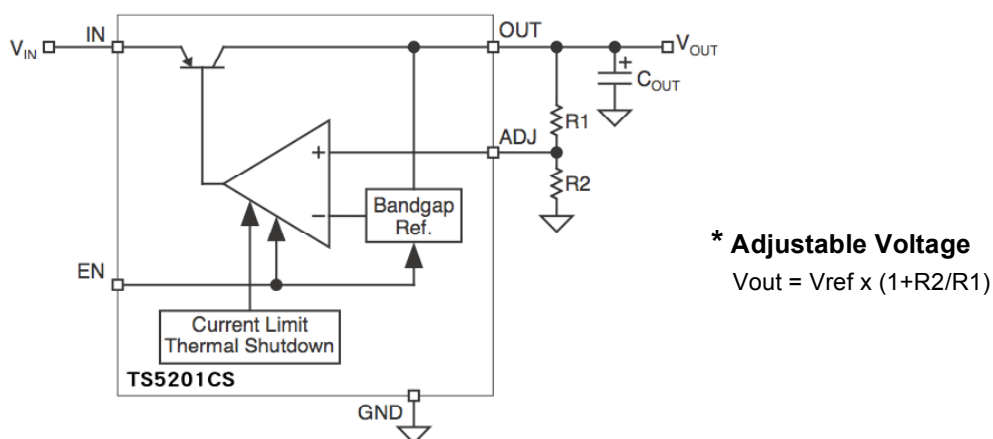
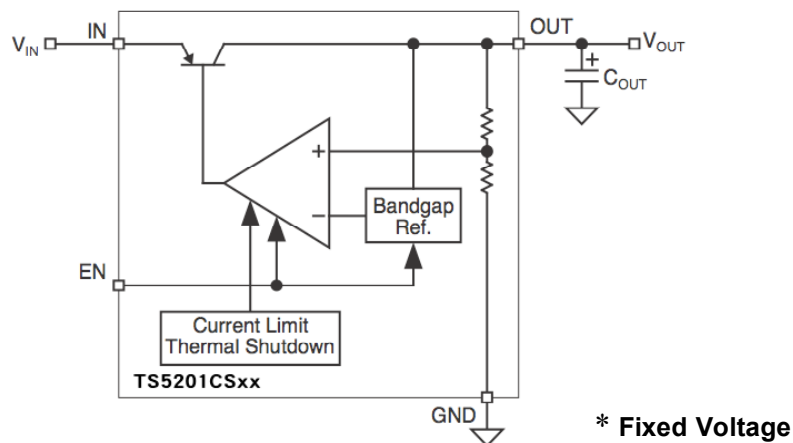

Application Information

Enable Input

TS5201 series feature an active-high (>2V) enable (EN) input that allows ON/OFF control of the regulator. Current drain reduces to “zero” when the device is shutdown, with only micro-amperes of leakage current. The EN is compatible with CMOS logic interfacing. EN may be directly tied to Vin and pulled up to the maximum supply voltage.

Input Capacitor Requirement

An input capacitor of 1uF or greater is recommended when the device is more than 10” away from the bulk AC supply capacitance or when the supply is a battery.

Reference Bypass Capacitor

Bypass is connected to the internal voltage reference. A 470uF capacitor (Cbypass) connected from Bypass to Ground quiets this reference, providing a significant reduction in output noise. Cbypass reduces the regulator phase margin; when using Cbypass, output capacitors of 2.2uF or greater are generally required to maintain stability.

The start up speed of the TS5201 is inversely proportional to the size of the reference bypass capacitor. Applications requiring a slow ramp up of output voltage should consider larger values of Cbypass. Likewise, if rapid turn on is necessary, consider omitting Cbypass. If output noise is not a major concern, omitted Cbypass and leave Bypass open.

Output Capacitor Requirement

The TS5201 series requires an output capacitor to maintain stability and improve transient response is necessary. The value of this capacitor is dependent upon whether a reference bypass capacitor is used. 1uF minimum is recommended when Cbypass is not used. 2.2uF minimum is recommended when Cbypass is 470uF. Larger values improve the regulator’s transient response. The output capacitor value may be increased without limit.

The output capacitor should have an ESR (effective series resistance) less than 5Ω and a resonant frequency above 1MHz. Ultra low ESR capacitors can cause a low amplitude oscillation on the output and/or under damped transient response.

Most of tantalum or aluminum electrolytic capacitors are adequate; film types will work. Since many aluminum electrolytic have electrolytes that freeze at about –30°C, solid tantalums are recommended for operation below –25°C. At lower values of output current, less output capacitance is required for output stability. The capacitor can be reduced to 0.47uF for current below 10mA or 0.33uF for currents below 1mA.

No Load Stability

The TS5201 series will remain stable and in regulation with no load, unlike many other voltage regulators. This is especially important in CMOS RAM keep alive applications.

Adjustable Regulator Design

The adjustable regulator versions can be adjusted to a specific output voltage by using two external resistors to programming the output voltage anywhere between 1.25 and the 16V maximum operating rating of the family.

Two resistors are used. Resistors can be quite large up to 470kΩ, because of the very high input impedance and low bias current of the sense comparator, the resistor values are calculated by:

$$V_{out} = 1.242V * (R2 / R1 + 1)$$

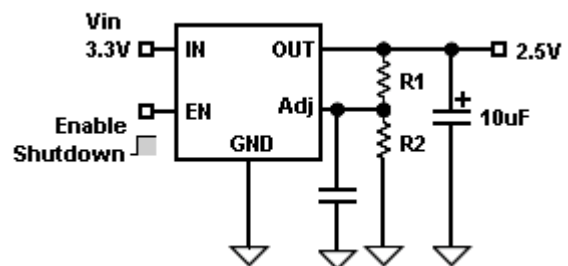

A capacitor from Adj to Ground provides greatly improved noise performance.

Dual Supply Operation

When used in dual supply systems where the regulator load is returned to a negative supply, the output voltage must be diode clamped to ground.

Application Information (continues)

Thermal Characteristics

TS5201 series is designed to provide 200mA of continuous current in a very small package. Maximum power dissipation can be calculated based on the output current and the voltage drop across the part. To determine the maximum power dissipation of the package, use the junction-ambient thermal resistance of the device and the following basic equation:

$$P_d(\max) = [T_j(\max) - T_a] / \theta_{ja}$$

$T_j(\max)$ is the maximum junction temperature of the die (125°C), and T_a is the ambient operating temperature. θ_{ja} is layout dependent, the actual power dissipation of the regulator circuit can be determined using the equation:

$$P_d = (V_{in} - V_{out}) * I_{out} + V_{in} * I_{gnd}$$

Substituting $P_d(\max)$ for P_d and solving for the operating conditions that are critical to the application will give the maximum operating conditions for the regulator circuit. For example, when operating the TS5201CX533 at room temperature with a minimum footprint layout, the maximum input voltage for a set output current can be determined as follows:

$$P_d(\max) = (125^\circ\text{C} - 25^\circ\text{C}) / 220^\circ\text{C/W}$$

$$P_d(\max) = 455\text{mW}$$

The junction to ambient thermal resistance for the minimum footprint is 220°C/W, the maximum power dissipation must not be exceeded for proper operation. Using the output voltage of 3.3V and an output current of 200mA, the maximum input voltage can be determined. From the electrical characteristics table, the maximum ground current for 200mA output current is 2.5mA.

$$445\text{mW} = (V_{in} - 3.3\text{V}) * 200\text{mA} + V_{in} * 2.5\text{mA}$$

$$445\text{mW} = V_{in} * 200\text{mA} - 3.3 * 200\text{mA} + V_{in} * 2.5\text{mA}$$

$$445\text{mW} = V_{in} * 200\text{mA} - 495\text{mW} + V_{in} * 2.5\text{mA}$$

$$950\text{mW} = V_{in} * 152.5\text{mA}$$

$$V_{in}(\max) = 6.23\text{V}$$

Therefore, a 3.3V application at 200mA of output current can accept a maximum input voltage of 6.23V in a SOT-25 package.

Noise Reduction Capacitors

On adjustable devices, a capacitor from ADJ to GND will decrease high frequency noise on the output. See following figure

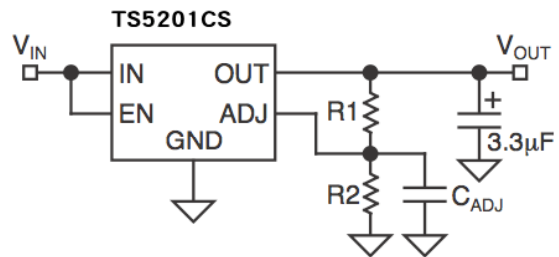

Minimum Load

The TS5201 will remain stable and in regulation with no load unlike many other voltage regulators. This is especially important in CMOS RAM keep-alive applications.

Dual-Supply Systems

When used in dual supply systems where the regulator load is returned to a negative supply, the output voltage must be diode clamped to ground.

SOP-8 Mechanical Drawing

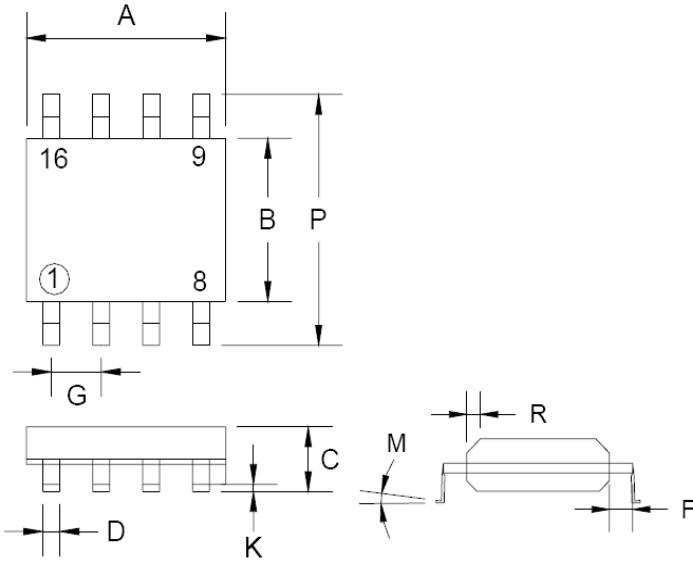

SOP-8 DIMENSION				
DIM	MILLIMETERS		INCHES	
	MIN	MAX	MIN	MAX
A	4.80	5.00	0.189	0.196
B	3.80	4.00	0.150	0.157
C	1.35	1.75	0.054	0.068
D	0.35	0.49	0.014	0.019
F	0.40	1.25	0.016	0.049
G	1.27 (typ)		0.05 (typ)	
K	0.10	0.25	0.004	0.009
M	0°	7°	0°	7°
P	5.80	6.20	0.229	0.244
R	0.25	0.50	0.010	0.019