

**DC-TO-DC CONVERTER CONTROL CIRCUITS**

**IL34063A**

The IL34063A is a monolithic control circuit containing the primary functions required for DC-to-DC converters. These devices consist of an internal temperature compensated reference, comparator, controlled duty cycle oscillator with an active current limit circuit, driver and high current output switch. This series was specifically designed to be incorporated in Step-Down and Step-Up and Voltage-Inverting applications with a minimum number of external components.

**FEATURES**

- Operation from 3.0 V to 40 V Input
- Low Standby Current
- Current Limiting
- Output Switch Current to 1.5 A
- Output Voltage Adjustable
- Frequency Operation to 100 kHz
- Precision 2% Reference

**FUNCTIONAL BLOCK DIAGRAM**

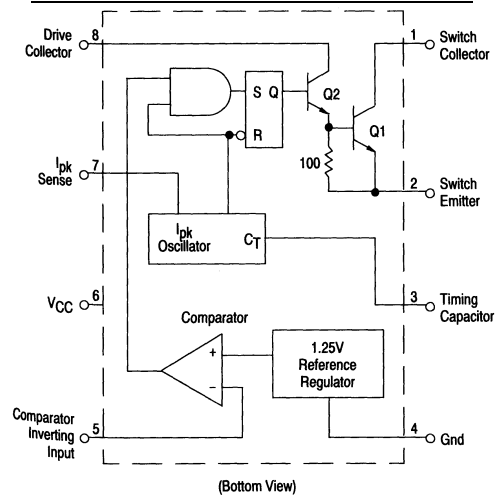

**MAXIMUM RATINGS**

Rating	Symbol	Value	Unit
Power Supply Voltage	V <sub>CC</sub>	40	Vdc
Comparator Input Voltage Range	V <sub>IR</sub>	-0.3 to +40	Vdc
Switch Collector Voltage	V <sub>C(switch)</sub>	40	Vdc
Switch Emitter Voltage (V <sub>pin 1</sub> = 40 V)	V <sub>E(switch)</sub>	40	Vdc
Switch Collector to Emitter Voltage	V <sub>CE(switch)</sub>	40	Vdc
Driver Collector Voltage	I <sub>C(driver)</sub>	40	Vdc
Driver Collector Current (Note 1)	I <sub>C(driver)</sub>	100	mA
Switch Current	I <sub>SW</sub>	1.5	A
Power Dissipation and Thermal Characteristics			
Ceramic Package, U Suffix T <sub>A</sub> = +25°C	P <sub>D</sub>	1.25	W
Thermal Resistance	R <sub>θJA</sub>	100	°C/W
Plastic Package, P Suffix T <sub>A</sub> = +25°C	P <sub>D</sub>	1.25	W
Thermal Resistance	R <sub>θJA</sub>	100	°C/W
SOIC Package, D Suffix T <sub>A</sub> = +25°C	P <sub>D</sub>	625	mW °C/W
Thermal Resistance	R <sub>θJA</sub>	160	
Operating Junction Temperature	T <sub>J</sub>	+150	°C
Operating Ambient Temperature Range	T <sub>A</sub>	0 to +70	°C
Storage Temperature Range	T <sub>stg</sub>	-65to+150	°C

\* Stresses beyond those listed under “absolute maximum ratings” may cause permanent damage to the device. These are stress ratings only and functional operation of the device at these or any other conditions beyond those indicated under “recommended operating conditions” is not implied. Exposure to absolute-maximum-rated conditions for extended periods may affect device reliability.

ORDERING INFORMATION

Device	Temperature Range	Package
34063AD	0° to +70°C	SO-8
34063AN		Plastic DIP

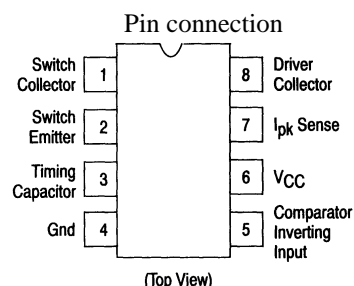

**ELECTRICAL CHARACTERISTICS**

(V<sub>CC</sub> = 5.0 V, T<sub>A</sub> = 0 to +70°C unless otherwise specified.)

Characteristics	Symbol	Min	Typ	Max	Unit
<b>OSCILLATOR</b>					
Frequency (V <sub>Pin5</sub> = 0 V, C <sub>T</sub> = 1.0 nF, T <sub>A</sub> = 25°C)	fosc	24	33	42	kHz
Charge Current (V <sub>CC</sub> = 5.0 V to 40 V, T <sub>A</sub> = 25°C)	I <sub>chg</sub>	24	33	42	μA
Discharge Current (V <sub>CC</sub> = 5.0 V to 40 V, T <sub>A</sub> = 25°C)	I <sub>dischg</sub>	140	200	260	μA
Discharge to Charge Current Ratio (Pin7 to V <sub>CC</sub> , T <sub>A</sub> = 25°C)	I <sub>dischg</sub> /I <sub>chg</sub>	5.2	6.2	7.5	—
Current Limit Sense Voltage (I <sub>chg</sub> = I <sub>dischg</sub> , T <sub>A</sub> = 25°C)	V <sub>ipk(sense)</sub>	250	300	350	mV
<b>OUTPUT SWITCH (Note 3)</b>					
Saturation Voltage, Darlington Connection (I <sub>SW</sub> = 1.0 A, Pins 1, 8 connected)	V <sub>CE(sat)</sub>	—	1.0	1.3	V
Saturation Voltage (I <sub>SW</sub> = 1.0 A, R <sub>Pin8</sub> = 82 Ω to V <sub>CC</sub> , Forced β = 20)	V <sub>CE(sat)</sub>	—	0.45	0.7	V
DC Current Gain (I <sub>SW</sub> = 1.0 A, V <sub>CE</sub> = 5.0 V, T <sub>A</sub> = 25°C)	h <sub>FE</sub>	50	120	—	—
Collector Off-State Current (V <sub>CE</sub> = 40V)	I <sub>C(off)</sub>	—	0.01	100	μA
<b>COMPARATOR</b>					
Threshold Voltage (T <sub>A</sub> = 25°C) (T <sub>A</sub> = T <sub>LOW</sub> to T <sub>HIGH</sub> )	V <sub>th</sub>	1.225 1.21	1.25 —	1.275 1.29	V
<b>Threshold Voltage (T<sub>A</sub> = 25°C) **</b>	<b>V<sub>th</sub></b>	<b>1.2375</b>	<b>1.25</b>	<b>1.2625</b>	<b>V</b>
Threshold Voltage Line Regulation (V <sub>CC</sub> = 3.0 V to 40 V)	Reg <sub>line</sub>	—	1.4	5.0	mV
Input Bias Current (V <sub>in</sub> = 0V)	I <sub>IB</sub>	—	-40	-400	nA
<b>TOTAL DEVICE</b>					
Supply Current (V <sub>CC</sub> = 5.0 V to 40 V, C <sub>T</sub> = 1.0 nF, V <sub>pin7</sub> = V <sub>CC</sub> , V <sub>Pin5</sub> > V <sub>th</sub> , Pin 2 = Gnd, Remaining pins open)	I <sub>CC</sub>	—	2.5	4.0	mA

NOTES:

- Maximum package power dissipation limits must be observed.
- Low duty cycle pulse techniques are used during test to maintain Junction temperature as close to ambient temperature as possible
- If the output switch is driven into hard saturation (non Darlington configuration) at low switch currents (< 300 mA) and high driver currents (>30 mA), it may take up to 2.0 μs to come out of saturation This condition will shorten the off time at frequencies > 30 kHz, and is magnified at high temperatures This condition does not occur with a Darlington configuration, since the output switch cannot saturate If a non Darlington configuration is used, the following output drive condition is recommended  
Forced β of output switch = I<sub>C</sub>, output/(I<sub>C</sub>, driver -7.0 mA\*) > 10

\*The 100 Ω resistor in the emitter of the driver device requires about 7.0 mA before the output switch conducts

\*\*Possible version for shipment

**TYPICAL APPLICATION CIRCUITS**

Step-Up Converter

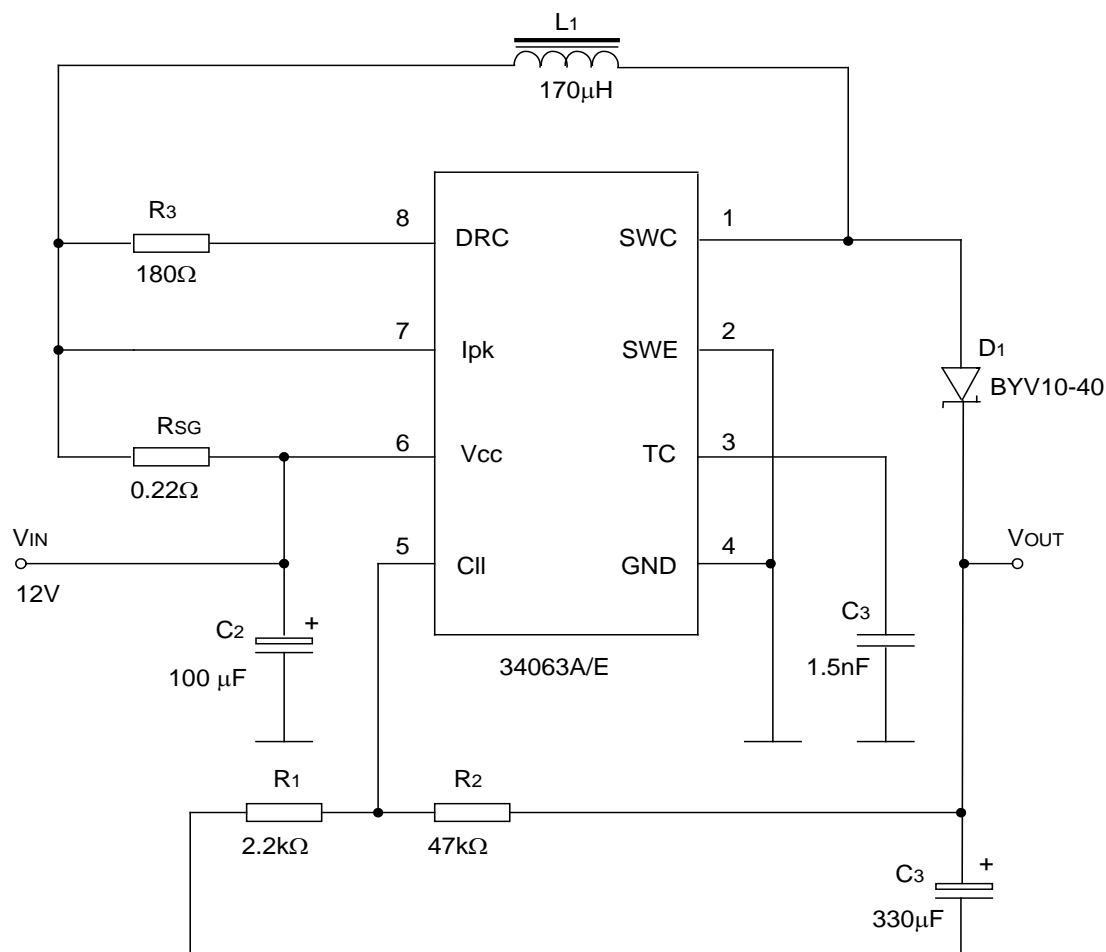

Test Condition ( $V_{OUT} = 28\text{ V}$ )

Test	Conditions	Value (Typ)	Unit
Line Regulation	$V_{IN} = 8\text{ to }16\text{ V}$ , $I_O = 175\text{ mA}$	30	mV
Load Regulation	$V_{IN} = 12\text{ V}$ , $I_O = 75\text{ to }175\text{ mA}$	10	mV
Output Ripple	$V_{IN} = 12\text{ V}$ , $I_O = 175\text{ mA}$	300	mV
Efficiency	$V_{IN} = 12\text{ V}$ , $I_O = 175\text{ mA}$	89	%

Step-Down Converter

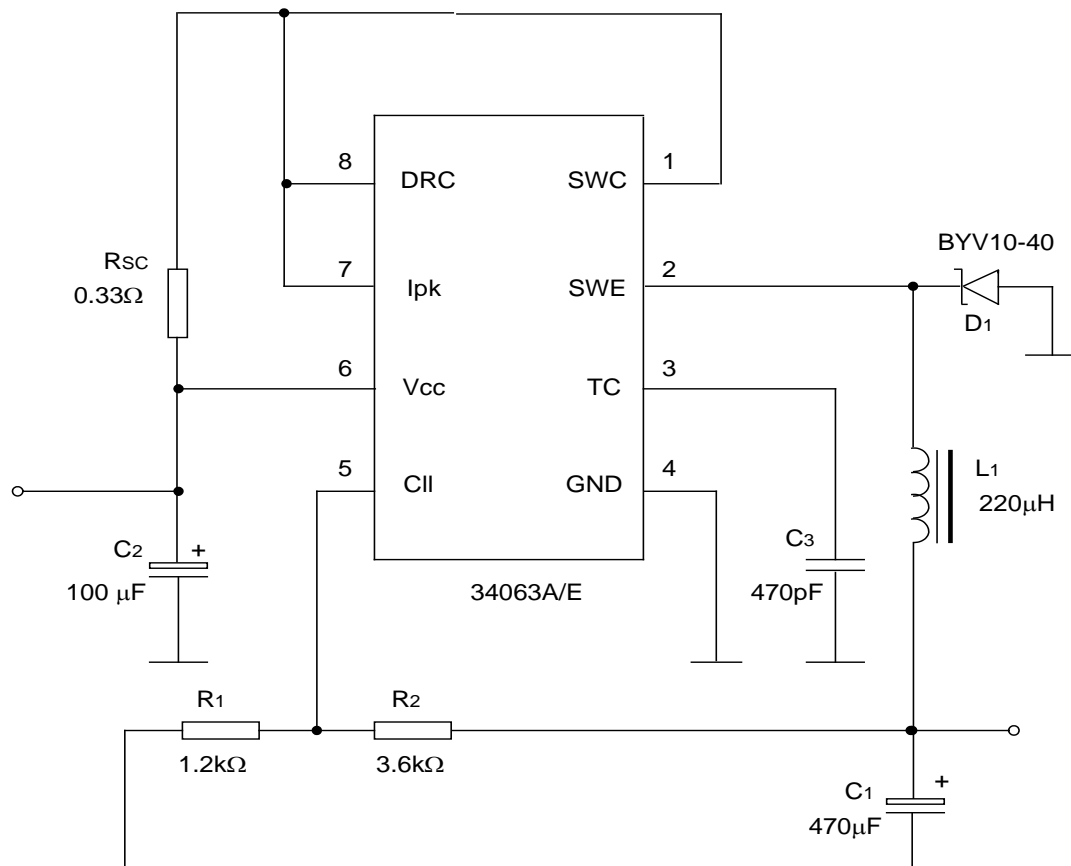

Test Condition ( $V_{OUT} = 5\text{ V}$ )

Test	Conditions	Value (Typ)	Unit
Line Regulation	$V_{IN} = 15\text{ to }25\text{ V}$ , $I_O = 500\text{ mA}$	5	mV
Load Regulation	$V_{IN} = 25\text{ V}$ , $I_O = 50\text{ to }500\text{ mA}$	30	mV
Output Ripple	$V_{IN} = 25\text{ V}$ , $I_O = 500\text{ mA}$	100	mV
Efficiency	$V_{IN} = 25\text{ V}$ , $I_O = 500\text{ mA}$	80	%
ISC	$V_{IN} = 25\text{ V}$ , $R_{LOAD} = 0.1\ \Omega$	1.2	A

Voltage Inverting Converter

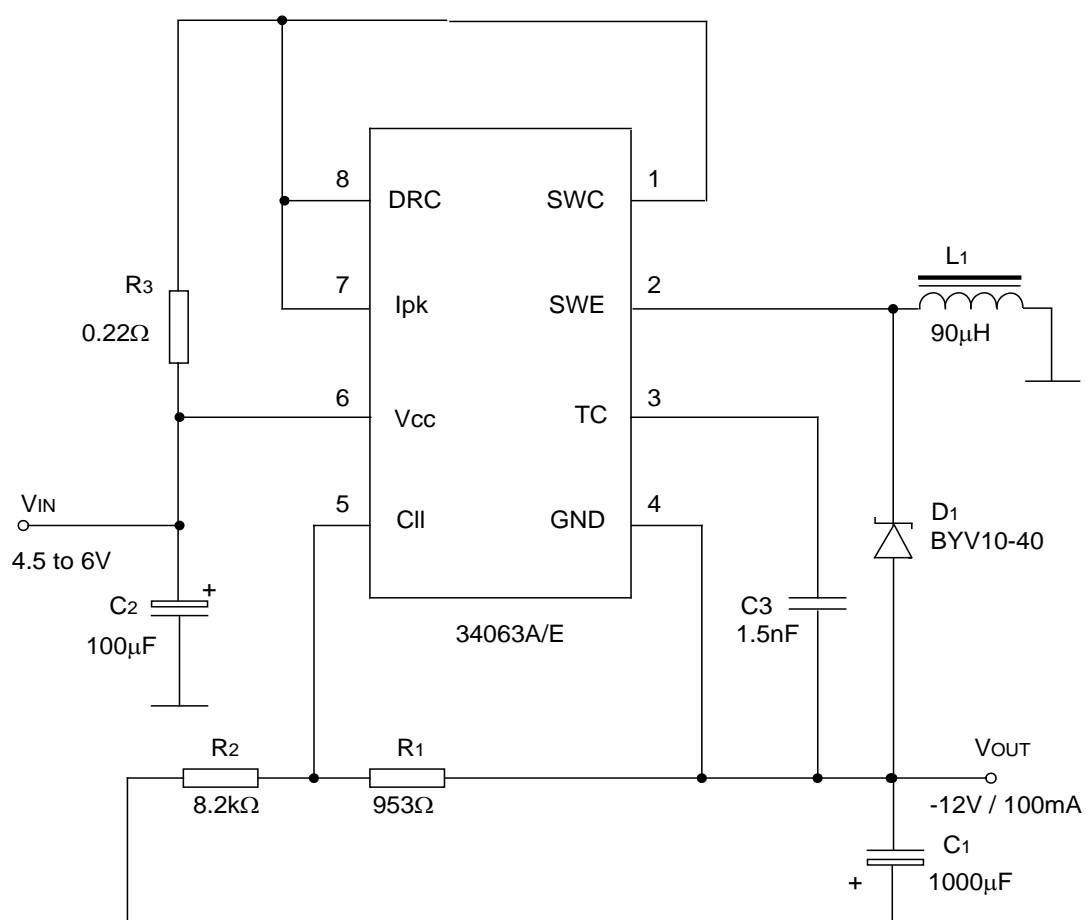

Test Condition ( $V_{OUT} = -12\text{ V}$ )

Test	Conditions	Value (Typ)	Unit
Line Regulation	$V_{IN} = 4.5\text{ to }6\text{ V}, I_O = 100\text{ mA}$	15	mV
Load Regulation	$V_{IN} = 5\text{ V}, I_O = 10\text{ to }100\text{ mA}$	20	mV
Output Ripple	$V_{IN} = 5\text{ V}, I_O = 100\text{ mA}$	230	mV
Efficiency	$V_{IN} = 5\text{ V}, I_O = 100\text{ mA}$	58	%
ISC	$V_{IN} = 5\text{ V}, R_{LOAD} = 0.1\ \Omega$	0.9	A

Calculation

Parameter	Step-Up (Discontinuous mode)	Step-Down (Continuous mode)	Voltage Inverting (Discontinuous mode)
$t_{on}/t_{off}$	$\frac{V_{out} + V_F - V_{in(min)}}{V_{in(min)} - V_{sat}}$	$\frac{V_{out} + V_F}{V_{in(min)} - V_{sat} - V_{out}}$	$\frac{ V_{out}  + V_F}{V_{in} - V_{sat}}$
$(t_{on} + t_{off})_{max}$	$\frac{1}{f_{min}}$	$\frac{1}{f_{min}}$	$\frac{1}{f_{min}}$
$C_T$	$4.5 \times 10^{-5} t_{on}$	$4.5 \times 10^{-5} t_{on}$	$4.5 \times 10^{-5} t_{on}$
$I_{PK( switch )}$	$2I_{out(max)}[(t_{on}/t_{off}) + 1]$	$2I_{out(max)}$	$2I_{out(max)}[(t_{on}/t_{off}) + 1]$
$R_{SC}$	$0.3/I_{PK( switch )}$	$0.3/I_{PK( switch )}$	$0.3/I_{PK( switch )}$
$C_O$	$\equiv \frac{I_{out} t_{on}}{V_{ripple(p-p)}}$	$\frac{I_{PK( switch )} (t_{on} + t_{off})}{8V_{ripple(p-p)}}$	$\equiv \frac{I_{out} t_{on}}{V_{ripple(p-p)}}$
$L(min)$	$\frac{V_{in(min)} - V_{sat}}{I_{PK( switch )}} t_{on(max)}$	$\frac{V_{in(min)} - V_{sat} - V_{out}}{I_{PK( switch )}} t_{on(max)}$	$\frac{V_{in(min)} - V_{sat}}{I_{PK( switch )}} t_{on(max)}$

NOTES:

$V_{sat}$  = Saturation voltage of the output switch

$V_F$  = Forward voltage drop of the output rectifier

THE FOLLOWING POWER SUPPLY CHARACTERISTICS MUST BE CHOSEN:

$V_{in}$  = Nominal input voltage

$V_{out}$  = Desired output voltage,  $|V_{out}| = 1.25(1 + R_2/R_1)$

$I_{out}$  = Desired output current

$f_{min}$  = Minimum desired output switching frequency at the selected values of  $V_{in}$  and  $l_o$

$V_{ripple}$  = Desired peak to peak output ripple voltage. In practice, the calculated capacitor value will and to be increased due to its equivalent series resistance and board layout. The ripple voltage should be kept to a low value since it will directly affect the line and load regulation.

Step-up With External NPN Switch

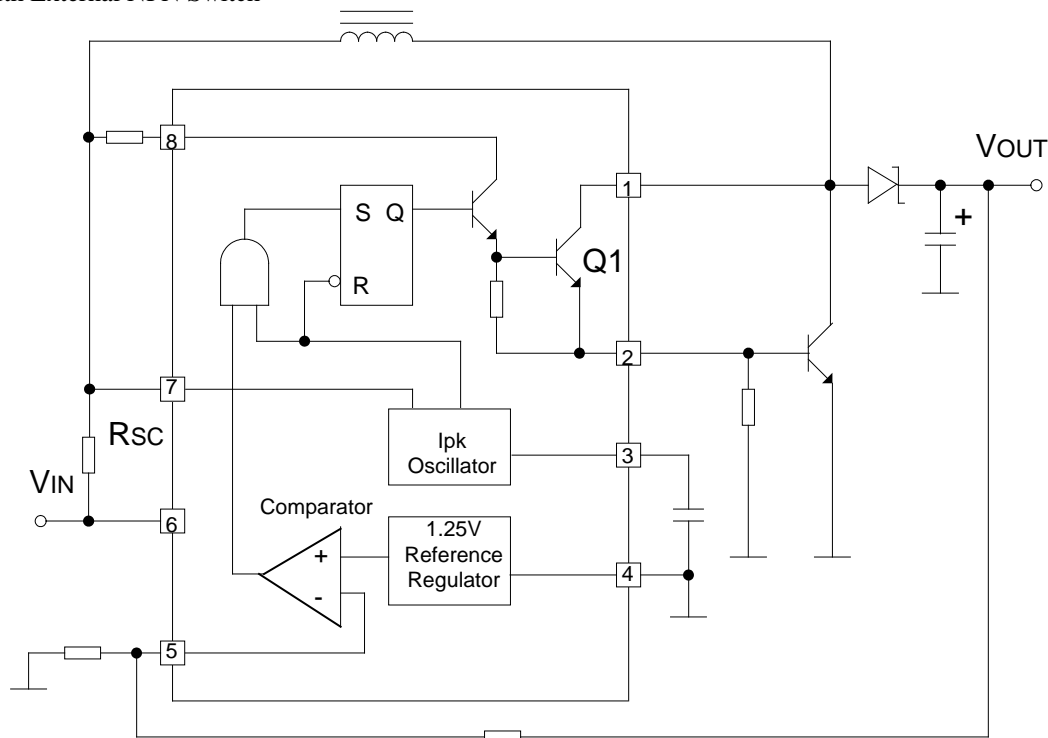

Step-down With External NPN Switch

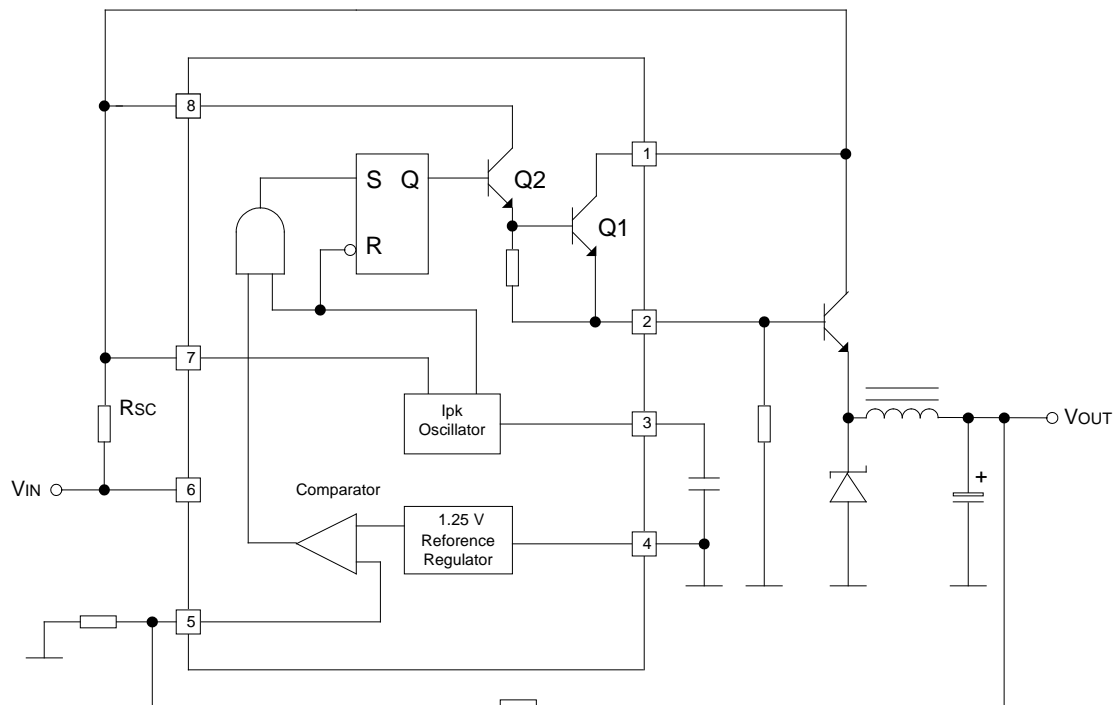

Step-down With External PNP Switch

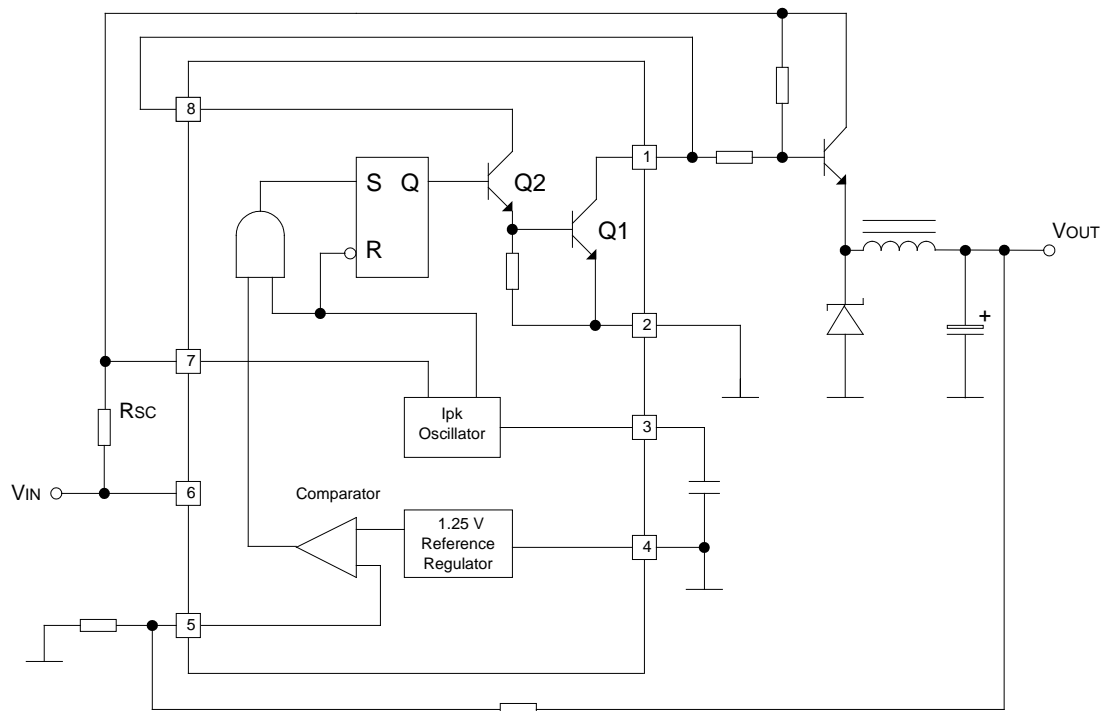

Voltage Inverting With External NPN Switch

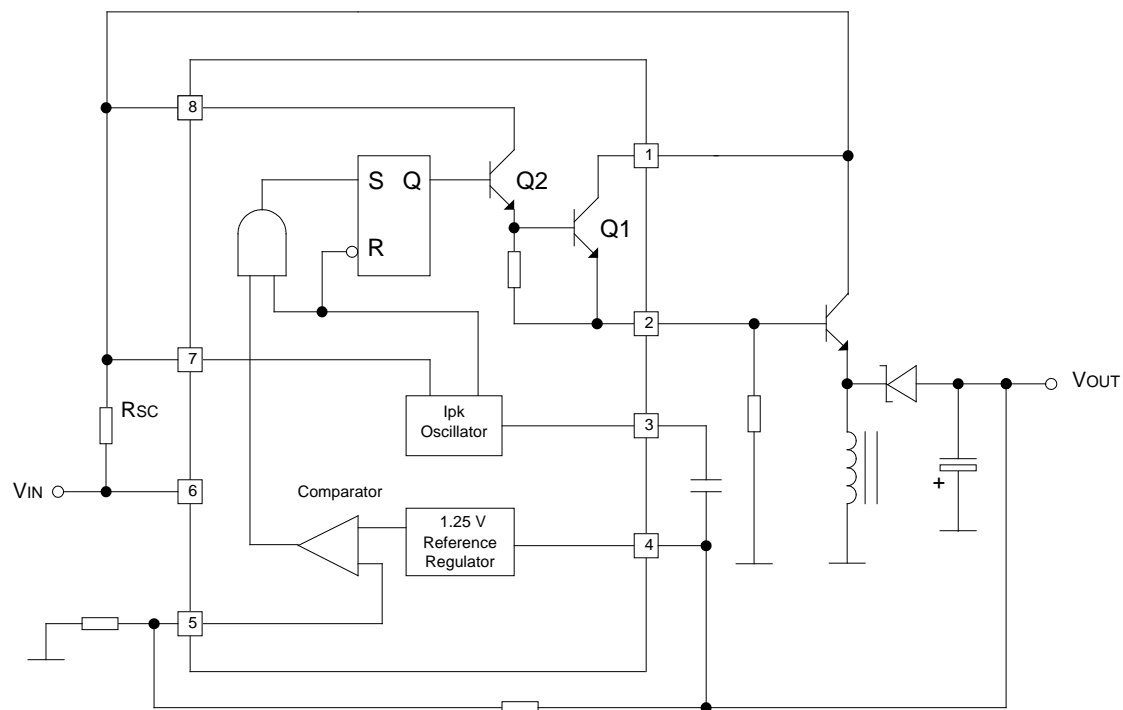

Voltage Inverting With External PNP Saturated Switch

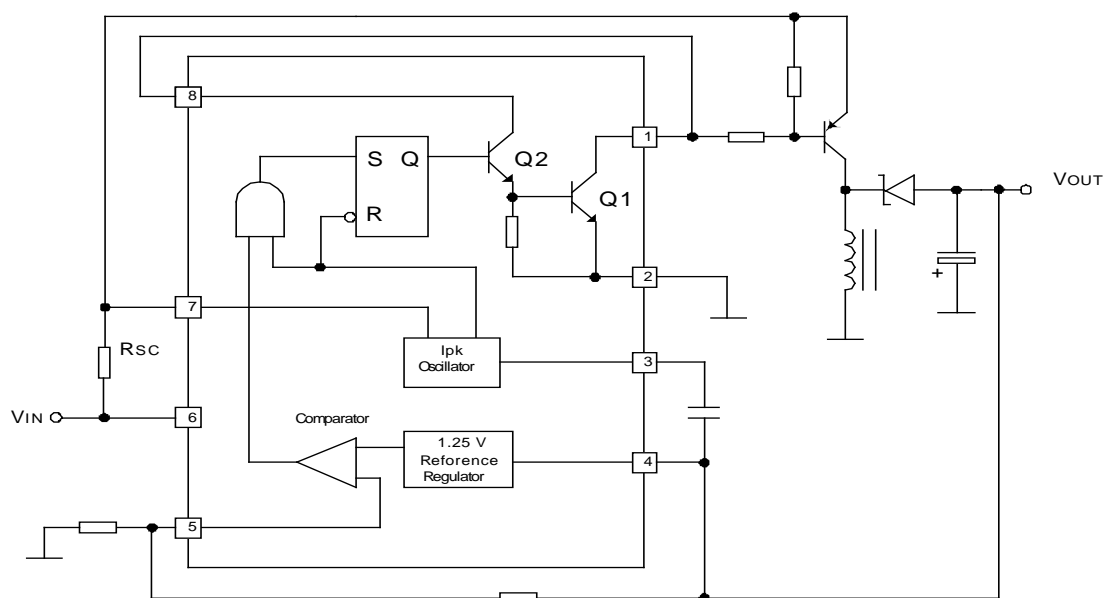



Dual Output Voltage

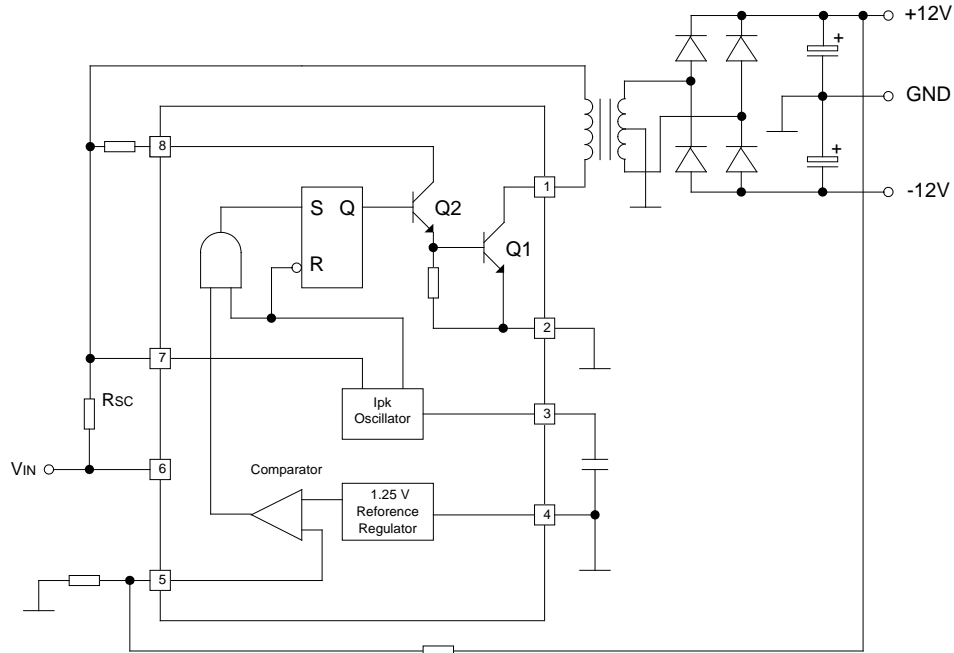

Higher Output Power, Higher Input Voltage

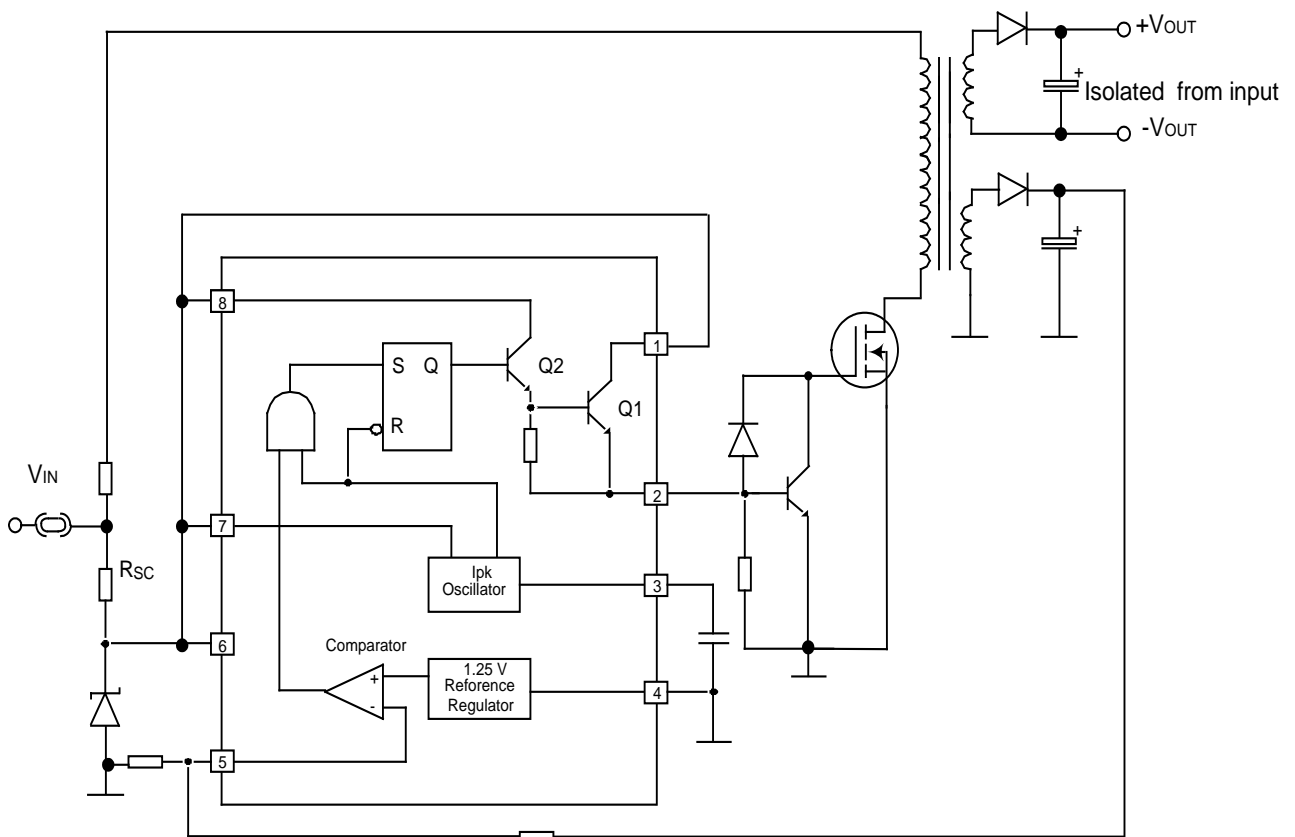

**N SUFFIX PLASTIC DIP  
(MS - 001BA)**

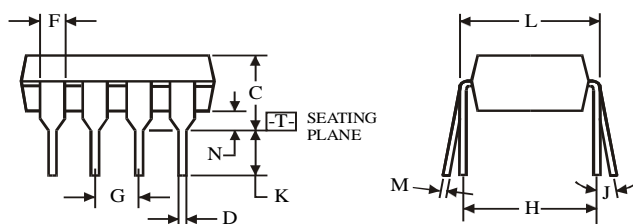
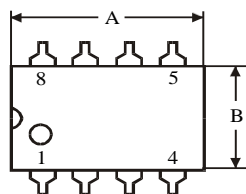
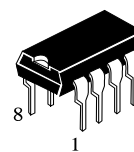

$\oplus 0.25 (0.010) \text{ (M) T}$

Symbol	Dimension, mm	
	MIN	MAX
A	8.51	10.16
B	6.1	7.11
C		5.33
D	0.36	0.56
F	1.14	1.78
G	2.54	
H	7.62	
J	0°	10°
K	2.92	3.81
L	7.62	8.26
M	0.2	0.36
N	0.38	

**NOTES:**

- Dimensions "A", "B" do not include mold flash or protrusions.  
Maximum mold flash or protrusions 0.25 mm (0.010) per side.

**D SUFFIX SOIC  
(MS - 012AA)**

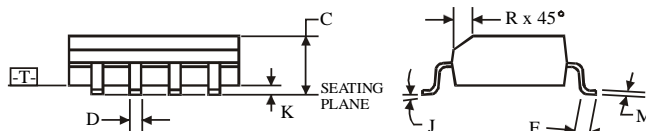
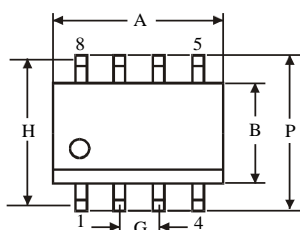
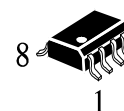

$\oplus 0.25 (0.010) \text{ (M) T C (M)}$

Symbol	Dimension, mm	
	MIN	MAX
A	4.8	5
B	3.8	4
C	1.35	1.75
D	0.33	0.51
F	0.4	1.27
G	1.27	
H	5.72	
J	0°	8°
K	0.1	0.25
M	0.19	0.25
P	5.8	6.2
R	0.25	0.5

**NOTES:**

- Dimensions A and B do not include mold flash or protrusion.
- Maximum mold flash or protrusion 0.15 mm (0.006) per side  
for A; for B - 0.25 mm (0.010) per side.