

### Circuit Designs Using Analog Devices Products

Apply these product pairings quickly and with confidence. For more information and/or support call 1-800-AnalogD (1-800-262-5643) or visit [www.analog.com/circuits](http://www.analog.com/circuits).

### Devices Connected/Referenced in this Circuit Note

ADL5535/ ADL5536	20 MHz to 1.0 GHz 16 dB/20 dB IF Gain Block
AD9268	16-Bit, 80 MSPS/105 MSPS/125 MSPS, 1.8 V Dual Analog-to-Digital Converter

## Low Noise, Low Distortion Single-Ended Input Drive Circuit for Differential Input IF Sampling ADCs

### CIRCUIT FUNCTION AND BENEFITS

The circuit shown in Figure 1 uses the ADL5535/ADL5536 single-ended IF low noise 50 Ω gain block to drive the AD9268 16-bit differential input analog-to-digital converter (ADC). The circuit includes an interstage bandpass filter for noise reduction and anti-aliasing. The use of a single-ended IF gain stage followed by a transformer to perform the single-ended-to-differential conversion is an optimum solution for this application where both low noise and low distortion are required.

The ADL5535/ADL5536 is a high linearity (third order output intercept, OIP3 = +45 dBm at 190 MHz), single-ended, fixed gain amplifier that can be used as a driver for high performance IF sampling of analog-to-digital converters. The ADL5535 has a gain of 16 dB and provides a simple approach to raise the signal from approximately 400 mV p-p to the 2 V p-p full-scale level required by the ADC. The ADL5535 low noise figure (3.2 dB at 190 MHz) and low distortion ensure that the ADC performance is not compromised. The ADL5536 can be used where a gain of 20 dB is required.

### CIRCUIT DESCRIPTION

Figure 1 shows the schematic of the ADL5535/ADL5536 driving the AD9268 16-bit ADC clocked at a sample rate of 122.88 MSPS. The ADL5535 has a single-ended input and output impedance of 50 Ω. A 1:1 impedance transformer (M/A-COM BA-007159-000000, 4.5 MHz to 3000 MHz), along with termination resistors and series ferrite beads, is used to present a 50 Ω load for the anti-aliasing filter interface. The filter interface between the ADL5535 and the AD9268 is a sixth-order Butterworth low-pass filter designed using a standard filter program. The interface provides a 50 MHz, 1 dB bandwidth centered around 175 MHz. Following the sixth-order filter, a shunt LC tank circuit (72 nH, 8.2 pF) was inserted to further reduce the low frequency response of the filter, giving more of a band-pass response to the filter. The normalized wideband response is shown in Figure 2.

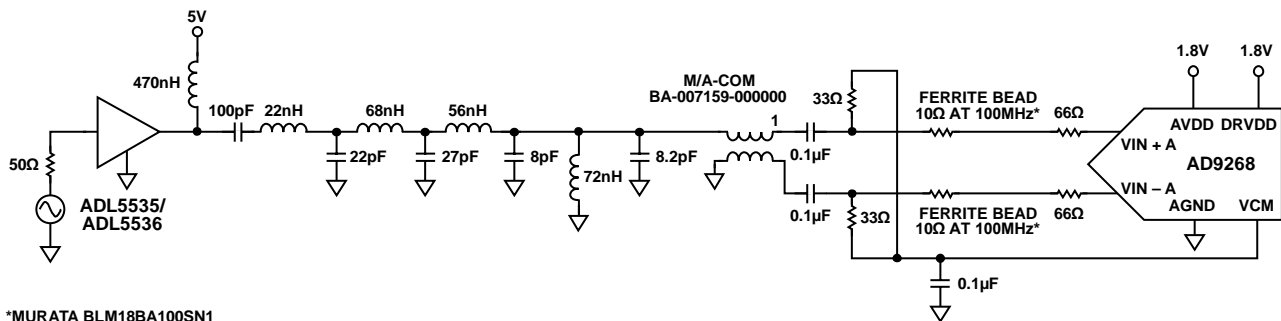

\*MURATA BLM18BA100SN1

Figure 1. Schematic of the ADL5535 Driving the AD9268 16-Bit ADC, (Simplified Schematic: All Connections and Decoupling Not Shown)

### Rev. 0

"Circuits from the Lab" from Analog Devices have been designed and built by Analog Devices engineers. Standard engineering practices have been employed in the design and construction of each circuit, and their function and performance have been tested and verified in a lab environment at room temperature. However, you are solely responsible for testing the circuit and determining its suitability and applicability for your use and application. Accordingly, in no event shall Analog Devices be liable for direct, indirect, special, incidental, consequential or punitive damages due to any cause whatsoever connected to the use of any "Circuit from the Lab". (Continued on last page)

The single-tone performance for an input frequency of 170 MHz and a sampling rate of 122.88 MSPS is shown in Figure 3. Two-tone performance is shown in Figure 4.

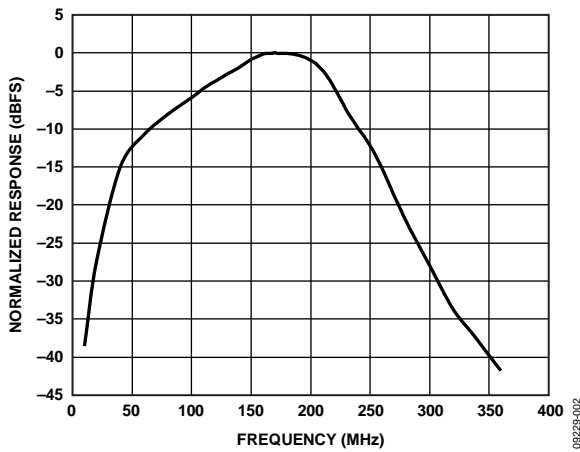

Figure 2. Normalized Frequency Response of the ADC Interface Shown in Figure 1

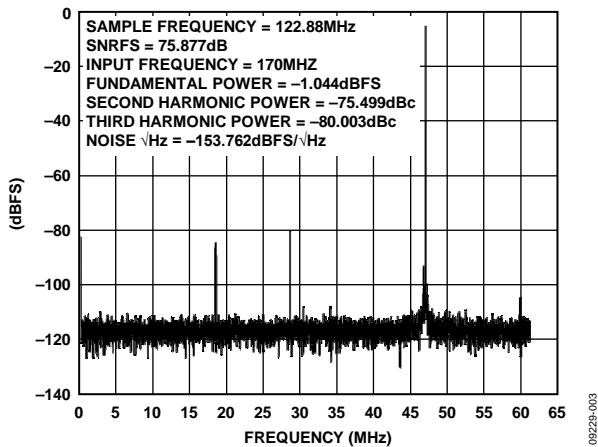

Figure 3. Measured Single-Tone Performance of the Circuit Shown in Figure 1 for an Input Frequency of 170MHz and Sampling Frequency of 122.88 MSPS

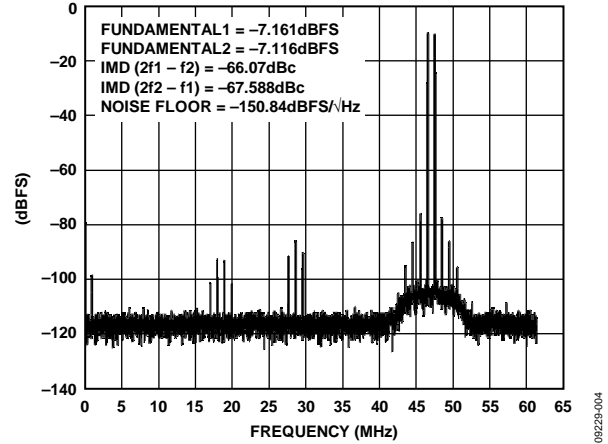

Figure 4. Measured Two-Tone Performance of the Circuit Shown in Figure 1 for Input Tones Centered at 170 MHz and a Sampling Rate of 122.88 MSPS

### COMMON VARIATIONS

The application circuit described here can be modified for any IF frequency within the operating range of the [ADL5535/ADL5536](#) and the [AD9268](#). As an alternative to the [AD9268](#), the [AD9640](#), the [AD6657](#), or the [AD9644](#) can be used for the ADC in this application.

**LEARN MORE**

AN-742 Application Note, *Frequency Domain Response of Switched Capacitor ADCs*, Analog Devices.

AN-827 Application Note, *A Resonant Approach to Interfacing Amplifiers to Switched-Capacitor ADCs*, Analog Devices.

CN-0002 Circuit Note, *Using the AD8376 VGA to Drive Wide Bandwidth ADCs for High IF AC-Coupled Applications*, Analog Devices.

CN-0046 Circuit Note, *An Ultra Low Distortion Differential RF/IF Front-End for High Speed ADCs*, Analog Devices.

Kester, Walt. *High Speed System Applications*, Chapter 2 "Optimizing Data Converter Interfaces," Analog Devices, 2006.

MT-007 Tutorial, *Aperture Time, Aperture Jitter, Aperture Delay Time—Removing the Confusion*, Analog Devices.

MT-031 Tutorial, *Grounding Data Converters and Solving the Mystery of "AGND" and "DGND,"* Analog Devices.

MT-073 Tutorial, *High Speed Variable Gain Amplifiers (VGAs)*, Analog Devices.

MT-075 Tutorial, *Differential Drivers for High Speed ADCs Overview*, Analog Devices.

MT-101 Tutorial, *Decoupling Techniques*, Analog Devices.

**Data Sheets and Evaluation Boards**

ADL5535

ADL5536

AD9268

AD9268 Evaluation Board

**REVISION HISTORY**

10/10—Revision 0: Initial Version

(Continued from first page) Circuits from the Lab circuits are intended only for use with Analog Devices products and are the intellectual property of Analog Devices or its licensors. While you may use the Circuits from the Lab circuits in the design of your product, no other license is granted by implication or otherwise under any patents or other intellectual property by application or use of the Circuits from the Lab circuits. Information furnished by Analog Devices is believed to be accurate and reliable. However, "Circuits from the Lab" are supplied "as is" and without warranties of any kind, express, implied, or statutory including, but not limited to, any implied warranty of merchantability, noninfringement or fitness for a particular purpose and no responsibility is assumed by Analog Devices for their use, nor for any infringements of patents or other rights of third parties that may result from their use. Analog Devices reserves the right to change any Circuits from the Lab circuits at any time without notice but is under no obligation to do so.

©2010 Analog Devices, Inc. All rights reserved. Trademarks and registered trademarks are the property of their respective owners.  
CN09229-0-10/10(0)



www.analog.com