

LITEON POWER SEMICONDUCTORS PBDF101 thru PBDF107

1 AMP. SILICON BRIDGE RECTIFIERS

VOLTAGE RANGE
50 to 1000 Volts
CURRENT
1.0 Ampere



- FEATURES**
- Rating to 1000V PRV
 - Surge overload rating to 30 Amperes peak
 - Ideal for printed circuit board
 - Reliable low cost construction utilizing molded plastic technique results in inexpensive product
 - UL Recognized file # E95060
 - Lead solderable per MIL-STD-202 method 208
 - Leads: silver plated copper, soldered plated
 - Plastic material has U/L flammability classification 94V-0
 - Polarity symbols molded on body
 - Weight: 0.02 ounce 0.45 grams

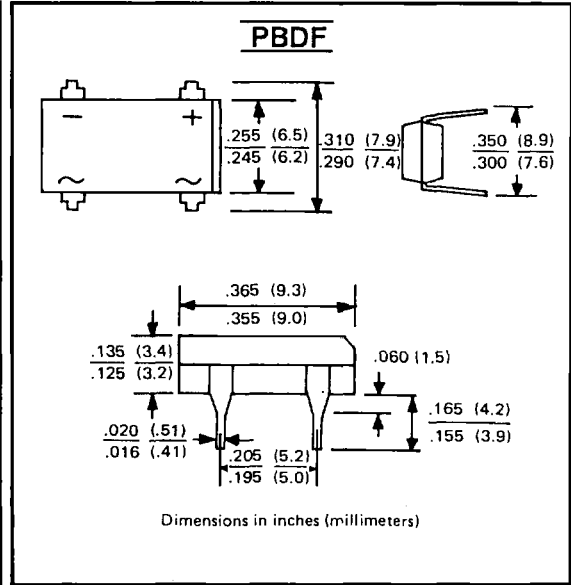

MAXIMUM RATINGS AND ELECTRICAL CHARACTERISTICS

Ratings at 25° C ambient temperature unless otherwise specified.
Single phase, half wave, 60Hz, resistive or inductive load,
For capacitive load, derate current by 20%.

		PBDF 101	PBDF 102	PBDF 103	PBDF 104	PBDF 105	PBDF 106	PBDF 107	UNITS
Maximum Recurrent Peak Reverse Voltage	V_{RRM}	50	100	200	400	600	800	1000	V
Maximum RMS Bridge Input Voltage	V_{RMS}	35	70	140	280	420	560	700	V
Maximum DC Blocking Voltage	V_{DC}	60	100	200	400	600	800	1000	V
Maximum Average Forward Output Current @ $T_A = 40^\circ C$	$I_{(AV)}$	1.0							A
Peak Forward Surge Current 8.3 ms single half sine-wave superimposed on rated load	I_{FSM}	30							A
Maximum DC Forward Voltage drop per element at 1.0A DC	V_F	1.1							V
Maximum DC Reverse Current at rated @ $T_A = 25^\circ C$ DC Blocking Voltage per element @ $T_A = 100^\circ C$	I_R	5 0.5							μA mA
$I^2 t$ Rating for fusing ($t < 8.3ms$)	$I^2 t$	3.7							$A^2 S$
Operating Temperature Range	T_J	-55 to + 125							$^\circ C$
Storage Temperature Range	T_{STG}	-55 to + 150							$^\circ C$

FIG. 1: PEAK FORWARD SURGE CURRENT

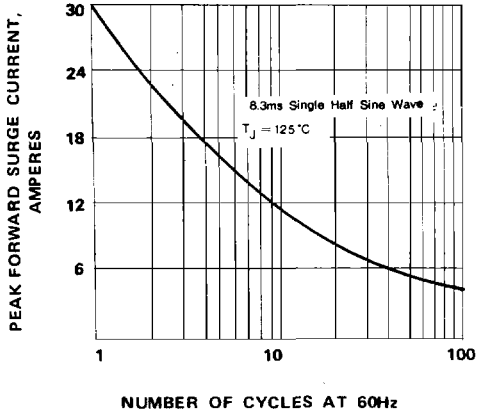

FIG. 2 FORWARD DERATING CURVE

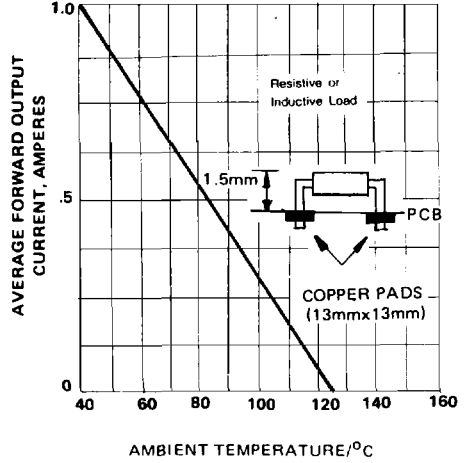

FIG. 3: TYPICAL FORWARD CHARACTERISTIC

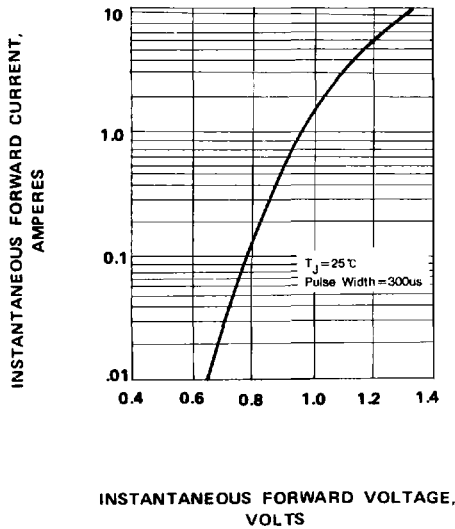
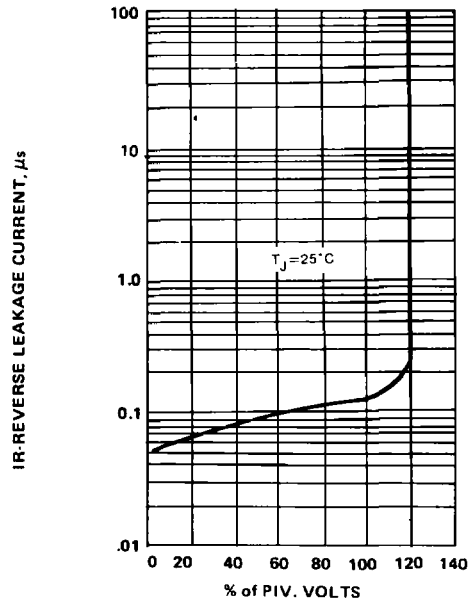

FIG. 4: TYPICAL REVERSE CHARACTERISTIC



8