

SPECIFICATIONS

Mechanical

Contact Retention Force: 1.0Kg min.

Electrical

Voltage Rating: 750V

Current Rating: 30A

Contact Resistance: 55mΩ max.

Dielectrical Withstanding Voltage: 1000V

Insulation Resistance: 1000MΩ min.

Physical

Housing: LCP, UL 94-0 rated, Ivory White

Contact: Phosphor Bronze

Plating: See "ORDERING INFORMATION"

FUTURE BUS CONNECTOR

1F Series

Power Header Solder Type

2.0mm Pitch

1 Row

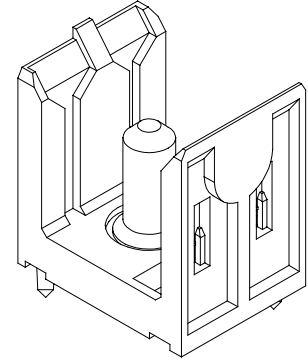

DRAWING

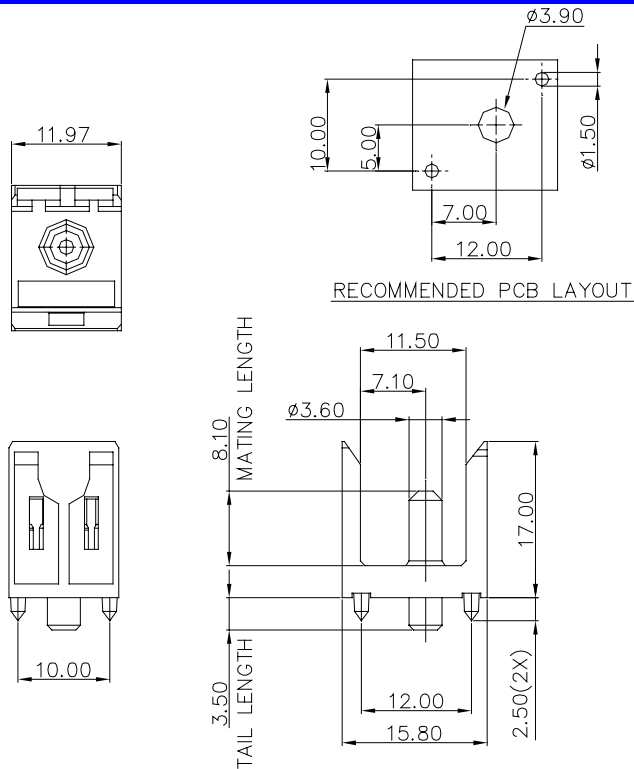

ORDERING INFORMATION

PRODUCT NO.: 1 F 6 3 0 0 1 * - S 7 6 H 0 * - * *

POS. NO.: _____
001=001 pos.

Mating Area Plating: _____
1=GOLD FLASH
3=0.76um(30u")MIN. GOLD PLATING
5=1.27um(50u")MIN. GOLD PLATING
6=0.25um(10u")MIN. GOLD PLATING
A=0.76um(30u")MIN. FPT PLATING,
0.25um(10u")MIN. GOLD INCLUDED

Tail Style: _____
S=Solder Type

Lead Free Code:
N=None
F=Lead Free

Package Type:
A=Tube

Extension Code:
N=Normal Plating

BODY STYLE
H0=Standard Part

Mating Length
6=8.10 mm
7=3.50mm