

Features

- -30V/-14.5A,
 $R_{DS(ON)} = 13m\Omega$ (Type) @ $V_{GS} = -10V$
 $R_{DS(ON)} = 22m\Omega$ (Type) @ $V_{GS} = -4.5V$
- Super High Dense Cell Design
- Reliable and Rugged
- ESD Protected
- Lead Free and Green Available

Applications

- Load Switching.
- PWM Applications.

Absolute Maximum Ratings

Pin Description

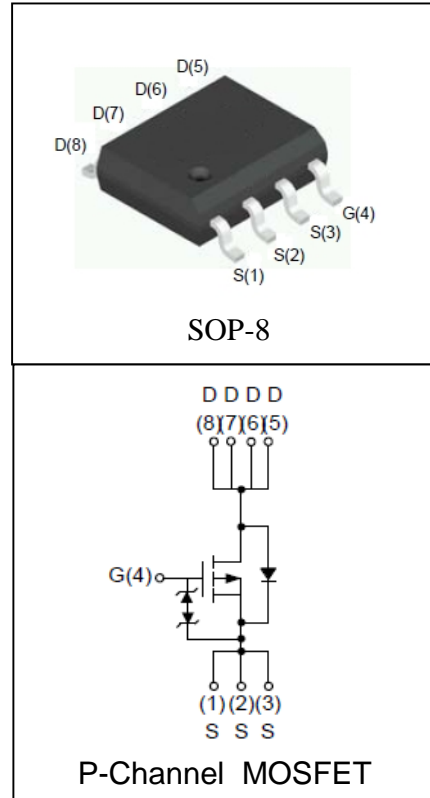

Symbol	Parameter	Rating	Unit
Common Ratings ($T_A = 25^\circ C$ Unless Otherwise Noted)			
V_{DSS}	Drain-Source Voltage	-30	V
V_{GSS}	Gate-Source Voltage	± 20	
T_J	Maximum Junction Temperature	150	$^\circ C$
T_{STG}	Storage Temperature Range	-55 to 150	$^\circ C$
I_S	Diode Continuous Forward Current	$T_C = 25^\circ C$ -14.5	A
Mounted on Large Heat Sink			
I_{DP}	300 μs Pulse Drain Current Tested	$T_C = 25^\circ C$ -58 ^①	A
I_D	Continuous Drain Current	$T_C = 25^\circ C$	A
		$T_C = 70^\circ C$	
P_D	Maximum Power Dissipation	$T_C = 25^\circ C$	W
		$T_C = 70^\circ C$	
$R_{\theta JA}$ ^②	Thermal Resistance-Junction to Ambient	40	$^\circ C/W$

Electrical Characteristics ($T_A=25^\circ\text{C}$ Unless Otherwise Noted)

Symbol	Parameter	Test Condition	RU30L15H			Unit
			Min.	Typ.	Max.	
Static Characteristics						
BV_{DSS}	Drain-Source Breakdown Voltage	$V_{GS}=0V, I_{DS}=-250\mu A$	-30			V
I_{DSS}	Zero Gate Voltage Drain Current	$V_{DS}=-30V, V_{GS}=0V$			-1	μA
		$T_J=85^\circ\text{C}$			-30	
$V_{GS(th)}$	Gate Threshold Voltage	$V_{DS}=V_{GS}, I_{DS}=-250\mu A$	-1	-1.8	-2.5	V
I_{GSS}	Gate Leakage Current	$V_{GS}=\pm 20V, V_{DS}=0V$			± 10	μA
$R_{DS(ON)}^{(3)}$	Drain-Source On-state Resistance	$V_{GS}=-10V, I_{DS}=-14A$		13	15	$m\Omega$
		$V_{GS}=-4.5V, I_{DS}=-10A$		22	28	$m\Omega$
Diode Characteristics						
$V_{SD}^{(3)}$	Diode Forward Voltage	$I_{SD}=-1A, V_{GS}=0V$			-1	V
t_{rr}	Reverse Recovery Time	$I_{SD}=-14A, dI_{SD}/dt=100A/\mu s$		30		ns
Q_{rr}	Reverse Recovery Charge			24		nC
Dynamic Characteristics ⁽⁴⁾						
R_G	Gate Resistance	$V_{GS}=0V, V_{DS}=0V, F=1\text{MHz}$		1.5		Ω
C_{iss}	Input Capacitance	$V_{GS}=0V,$ $V_{DS}=-15V,$ Frequency=1.0MHz		2300		pF
C_{oss}	Output Capacitance			250		
C_{rss}	Reverse Transfer Capacitance			160		
$t_{d(ON)}$	Turn-on Delay Time	$V_{DD}=-15V, R_L=30\Omega,$ $I_{DS}=-14A, V_{GEN}=-10V,$ $R_G=6\Omega$		12		ns
t_r	Turn-on Rise Time			20		
$t_{d(OFF)}$	Turn-off Delay Time			38		
t_f	Turn-off Fall Time			18		
Gate Charge Characteristics ⁽⁴⁾						
Q_g	Total Gate Charge	$V_{DS}=-24V, V_{GS}=-10V,$ $I_{DS}=-14A$		39	50	nC
Q_{gs}	Gate-Source Charge			8		
Q_{gd}	Gate-Drain Charge			12		

- Notes: ① Pulse width limited by safe operating area.
 ② When mounted on 1 inch square copper board, $t \leq 10\text{sec}$. The value in any given application depends on the user's specific board design.
 ③ Pulse test ; Pulse width $\leq 300\mu s$, duty cycle $\leq 2\%$.
 ④ Guaranteed by design, not subject to production testing.

Typical Characteristics

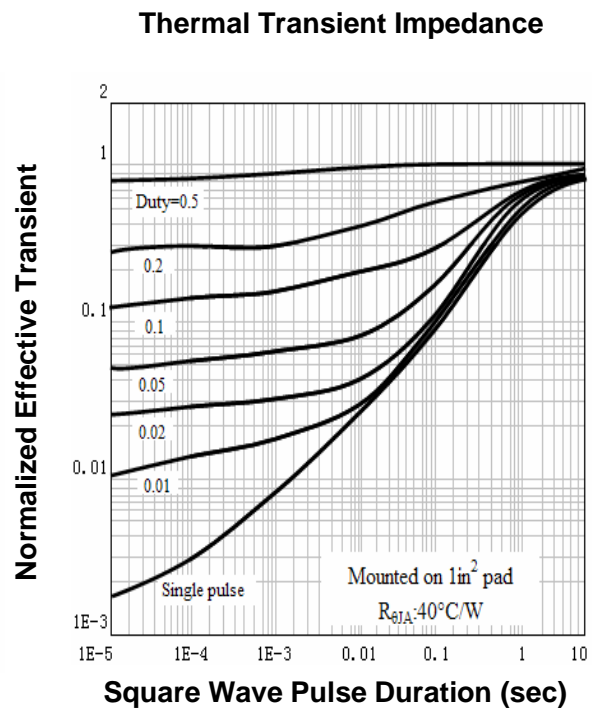
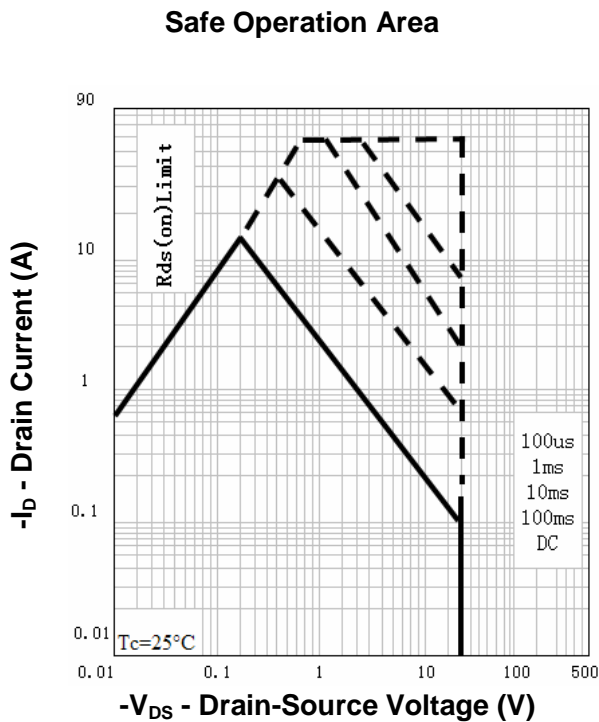
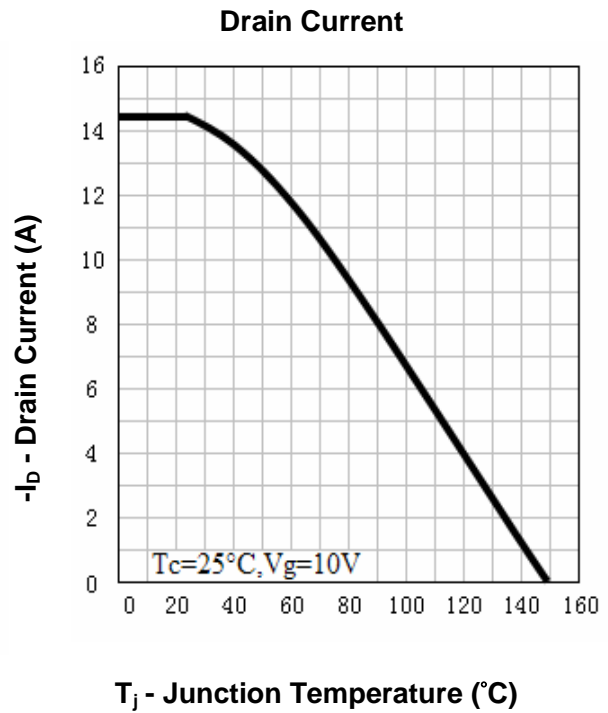
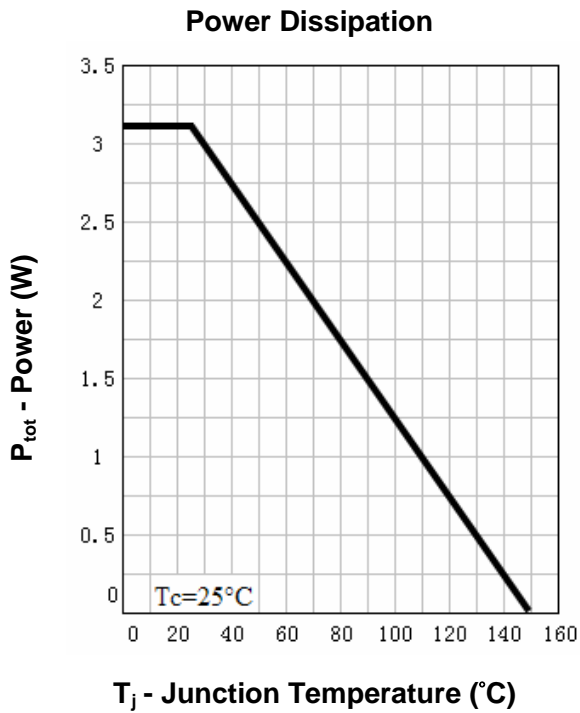

Typical Characteristics

Output Characteristics

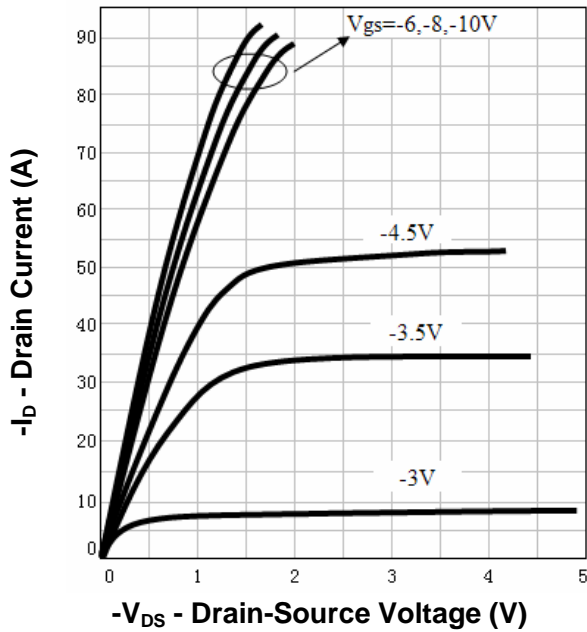

Drain-Source On Resistance

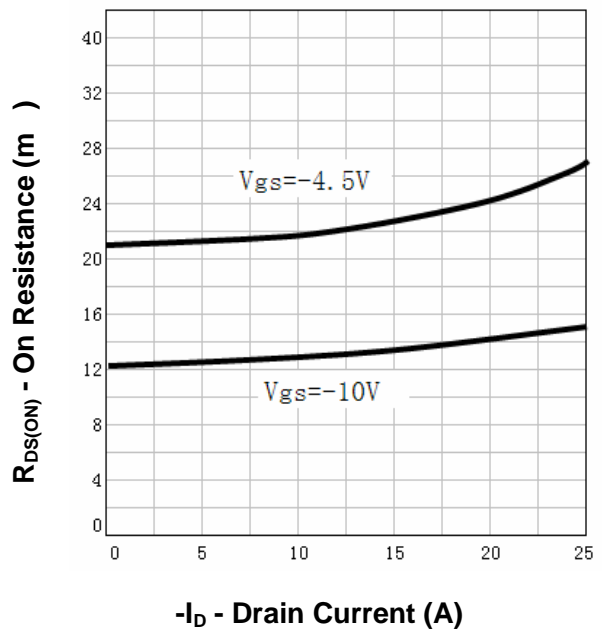

Drain-Source On Resistance

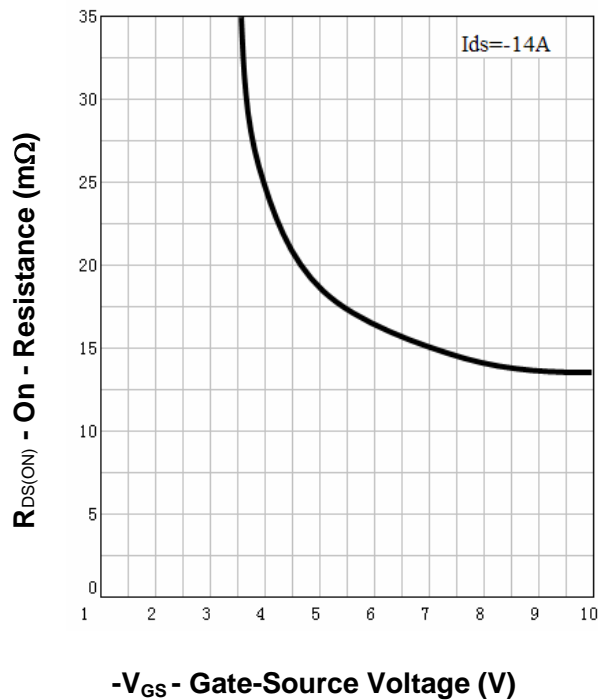

Gate Threshold Voltage

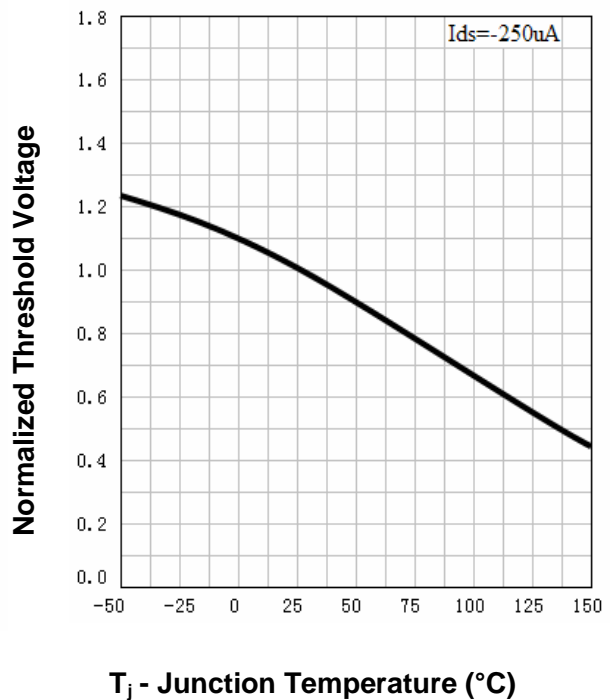

Typical Characteristics

Drain-Source On Resistance

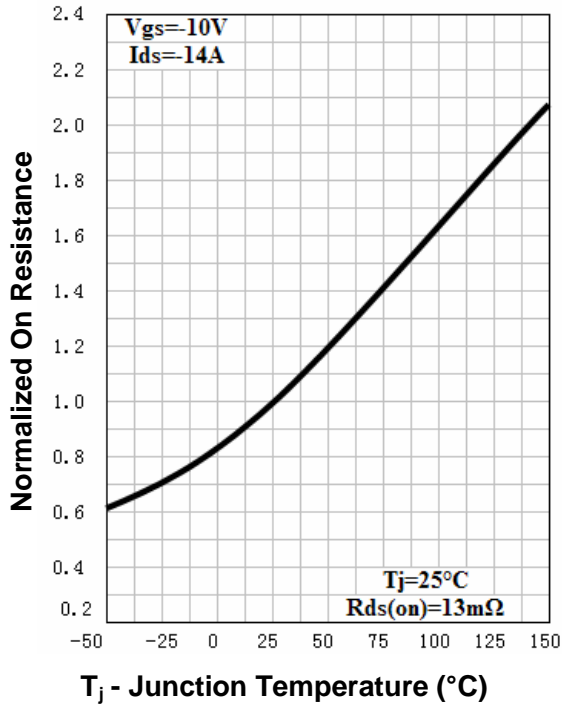

Source-Drain Diode Forward

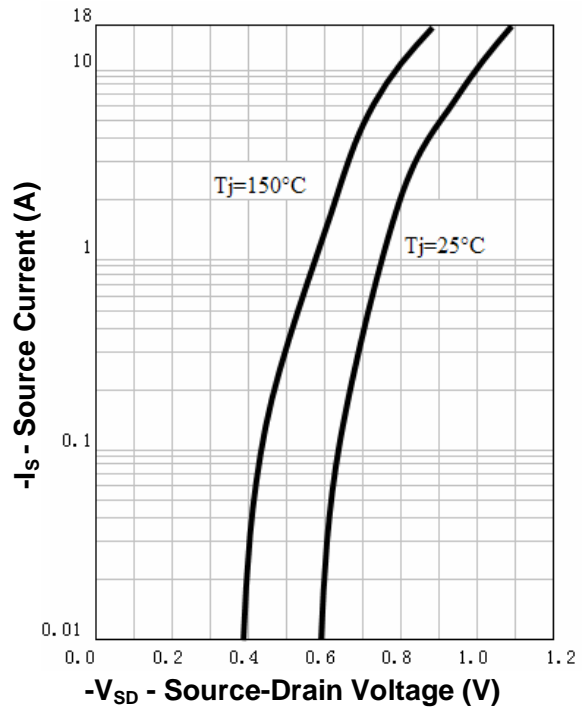

Capacitance

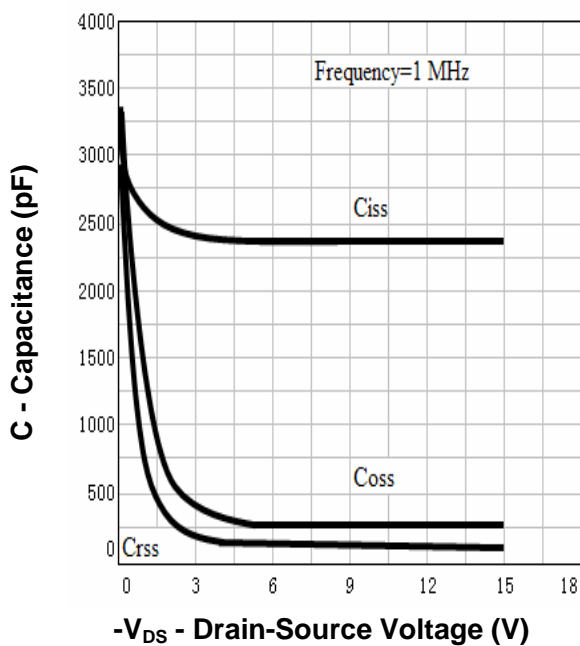

Gate Charge

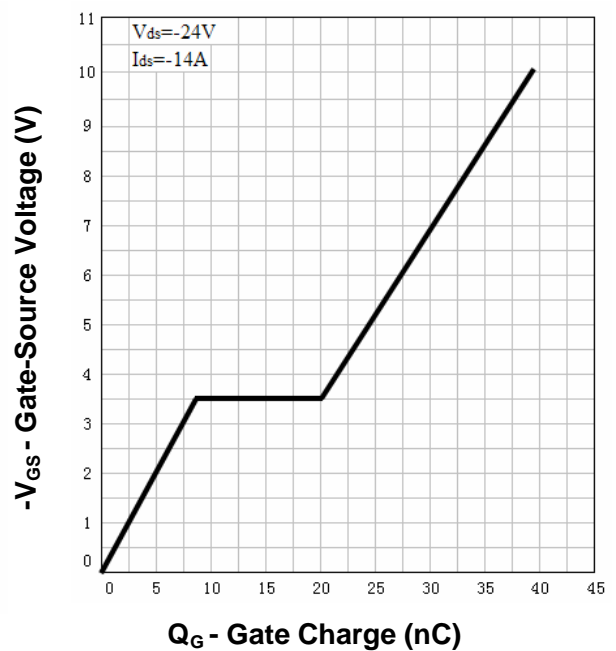

Avalanche Test Circuit and Waveforms

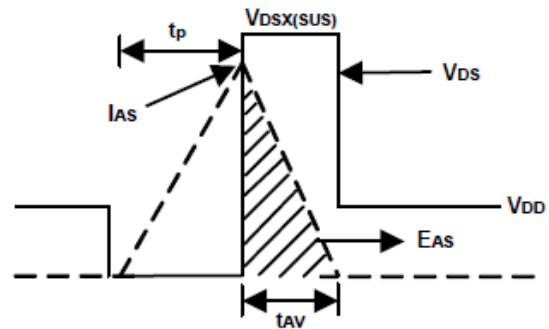
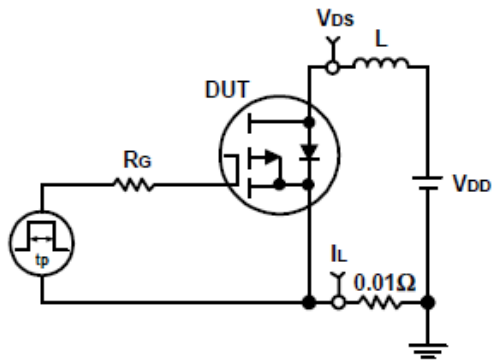

Switching Time Test Circuit and Waveforms

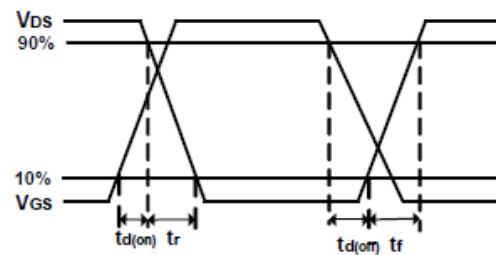
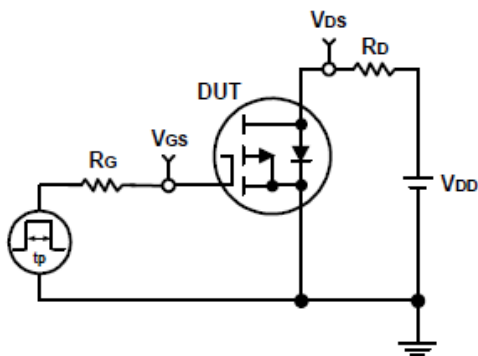

Ordering and Marking Information**RU30L15****Package (Available)**

H : SOP-8

Operating Temperature Range

C : -55 to 150 °C

Assembly Material

G : Green & Lead Free

Packaging

T : TUBE

TR : Tape & Reel

Package Information

SOP-8

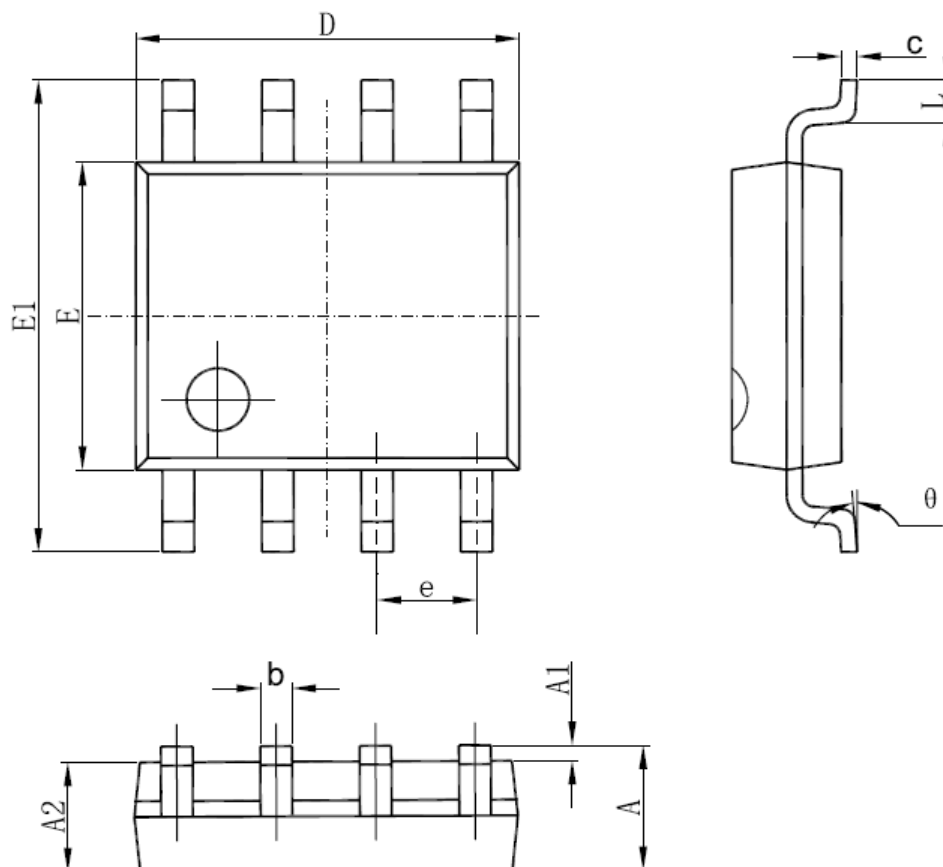

SYMBOL	MM		INCH		SYMBOL	MM		INCH	
	MIN	MAX	MIN	MAX		MIN	MAX	MIN	MAX
A	1.350	1.750	0.053	0.069	E	3.800	4.000	0.150	0.157
A1	0.100	0.250	0.004	0.010	E1	5.800	6.200	0.228	0.244
A2	1.350	1.550	0.053	0.061	e	1.270 (BSC)		0.050 (BSC)	
b	0.330	0.510	0.013	0.020	L	0.400	1.270	0.016	0.050
c	0.170	0.250	0.006	0.010	θ	0°	8°	0°	8°
D	4.700	5.100	0.185	0.200					

ALL DIMENSIONS REFER TO JEDEC STANDARD
DO NOT INCLUDE MOLD FLASH OR PROTRUSIONS

Customer Service

Worldwide Sales and Service:

Sales@ruichips.com

Technical Support:

Technical@ruichips.com

Investor Relations Contacts:

Investor@ruichips.com

Marcom Contact:

Marcom@ruichips.com

Editorial Contact:

Editorial@ruichips.com

HR Contact:

HR@ruichips.com

Legal Contact:

Legal@ruichips.com

Shen Zhen RUICHIPS Semiconductor CO., LTD

Room 501, the 5floor An Tong Industrial Building,
NO.207 Mei Hua Road Fu Tian Area Shen Zhen City, CHINA

TEL: (86-755) 8311-5334

FAX: (86-755) 8311-4278

E-mail: Sales-SZ@ruichips.com