

System LSIs for CD/DVD Drive & Recorder

# System Motor Driver IC for Half Height Drive(Sensorless)



BD7789RFS

TARGET SPEC(2008.05.07)

### ●Description

BD7789RFS are energy-saving, low noise ICs, developed for the spindle motor, actuator coil, tilt coil, stepping motor, and the loading motor drive of the desktop PC/DVD recorder. The actuator, tilt, and loading driver use a linear BTL drive system and the spindle and stepping motor driver use power MOSFET. Due to the motor's sensorless functionality, a reduction in the number of external parts and wiring is achieved.

### ●Features

- 1) Simple low revolution control with LRPM mode.
- 2) Hall sensors are not required
- 3) The spindle motor driver achieves a high speed start and driver stability by the drive system of an original ROHM.
- 4) Highly effective spindle and the stepping driver is achieved by built-in internal detection circuit (External resistance is unnecessary.) and PWM control driver.
- 5) Linear BTL drive system for low noise output.
- 6) ON/OFF of loading, brake mode of spindle driver, and standby mode are selectable by the two control terminals.
- 7) Built-in thermal-shut down circuit.
- 8) Built-in oscillator circuit.
- 9) Improved heat radiation efficiency utilizing HTSSOP package.

### ●Applications

Optical disk equipment, such as desktop PC/DVD recorders

### ●Absolute maximum ratings

Parameter	Symbol	Limits	Unit
POWER MOS power supply voltage	SPVM, SLVM	15 #1	V
Preblock/BTL power block power supply voltage	Vcc, AVM, LDVM	15	V
PWM control block power supply voltage	DVcc	7	V
Power dissipation	Pd	2.0 #2	W
Operating temperature range	Topr	-20~70	°C
Storage temperature	Tstg	-55~150	°C

#1 POWER MOS output terminals (29~32pin, 35~37pin) are contained.

#3 PCB mounting (70mmX70mmX1.6mm, occupied copper foil is less than 3%, glass epoxy standard board).  
Reduce by 16mW/°C over 25°C (see p.11)

### ●Recommended operating conditions

(Set the power supply voltage with consideration to power dissipation)

Parameter	Symbol	Min.	Typ.	Max.	Unit
Spindle driver powerblock power supply voltage	SPVM	—	Vcc <sup>#3</sup>	—	V
Sled motor driver powerblock power supply voltage	SLVM	—	Vcc <sup>#3</sup>	—	V
Preblock power supply voltage	Vcc	10.8	12	13.2	V
Loading driver power block power supply voltage	LDVM	4.3	5.0	Vcc	V
Actuator driver power block power supply voltage	AVM	4.3	5.0	5.5	V
PWM control block power supply voltage	DVcc	4.3	5.0	5.5	V
Spindle driver output current	Iosp	—	1.0	2.5 <sup>#4</sup>	A
Actuator/sled motor/loading motor driver output current	Ioo	—	0.5	0.8	A

#3 Set the same supply voltage to SPVM, SLVM and Vcc.

#4 The current is guaranteed 3.5A in case of the short-circuit braking mode and the current which is turned on/off in a duty-ratio of less than 1/10 with a maximum on-time of 5msec.

May,2008



● Block diagram

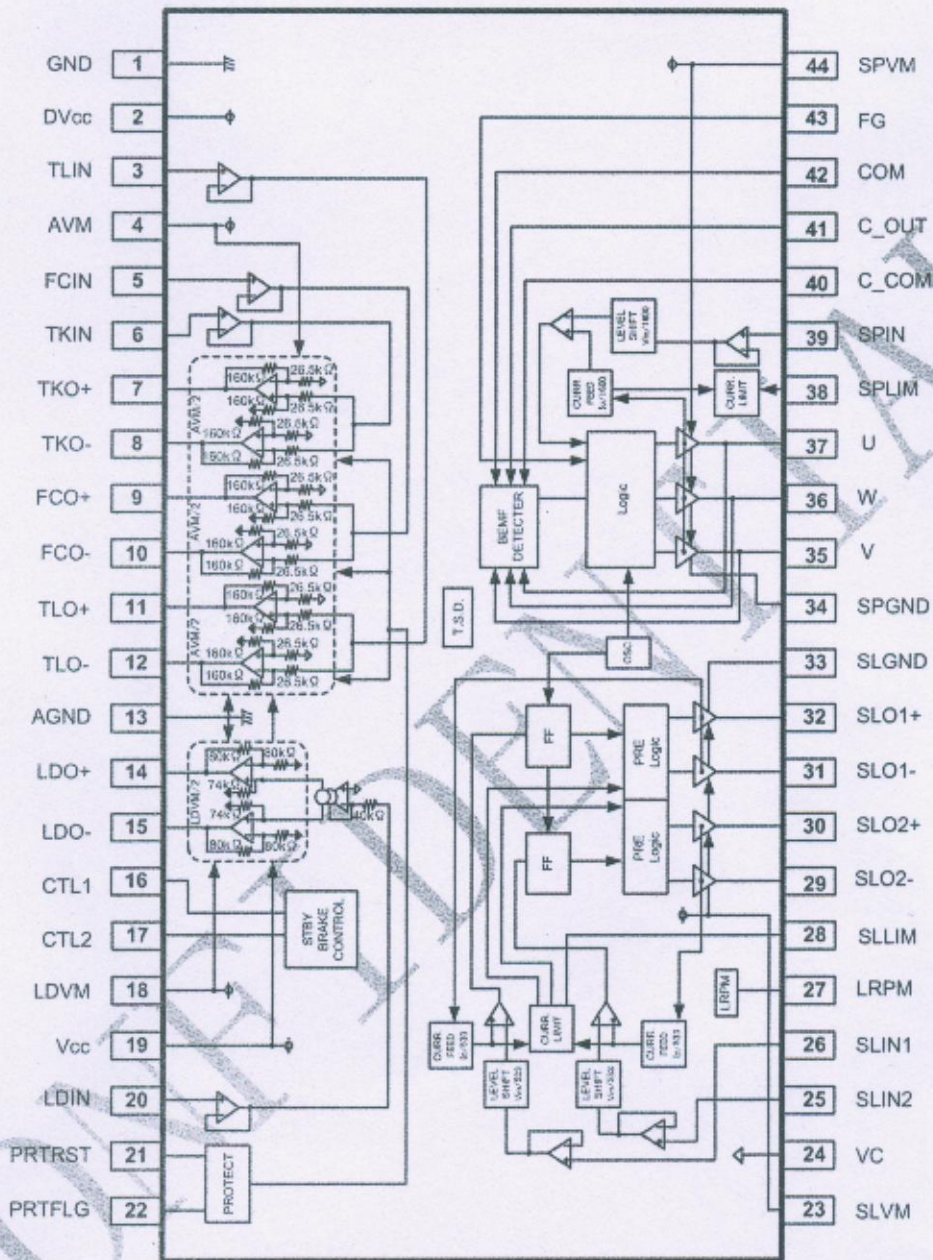



● Pin description

No.	Symbol	Description	No.	Symbol	Description
1	GND	Pre-GND	23	SLVM	Sled driver power supply
2	DVcc	PWM block control power supply	24	VC	Reference voltage input
3	TLIN	Tilt driver input	25	SLIN2	Sled driver2 input
4	AVM	Actuator driver power supply	26	SLIN1	Sled driver1 input
5	FCIN	Focus driver input	27	LRPM	Low revolution control input
6	TKIN	Tracking driver input	28	SLLIM	Adjustable resistor connection for sled driver current limit
7	TKO+	Tracking driver positive output	29	SLO2-	Sled driver2 negative output
8	TKO-	Tracking driver negative output	30	SLO2+	Sled driver2 positive output
9	FCO+	Focus driver positive output	31	SLO1-	Sled driver1 negative output
10	FCO-	Focus driver negative output	32	SLO1+	Sled driver1 positive output
11	TLO+	Tilt driver positive output	33	SLGND	Sled driver power ground
12	TLO-	Tilt driver negative output	34	SPGND	Spindle driver power ground
13	AGND	Actuator and loading motor driver power ground	35	V	Spindle driver output V
14	LDO+	Loading driver positive output	36	W	Spindle driver output W
15	LDO-	Loading driver negative output	37	U	Spindle driver output U
16	CTL1	Driver logic control input1	38	SPLIM	Adjustable resistor connection for spindle driver current limit
17	CTL2	Driver logic control input2	39	SPIN	Spindle driver input
18	LDVM	Loading driver power supply	40	C_COM	Smoothing capacitor connection (COM side)
19	Vcc	Pre block power supply	41	C_OUT	Smoothing capacitor connection (output side)
20	LDIN	Loading driver input	42	COM	Motor coil center point input
21	PRTRST	Protect reset input	43	FG	Frequency generator output
22	PRTFLG	Protect flag output	44	SPVM	Spindle driver power supply

\*Positive/negative of the output terminals are determined in reference to those of the input terminals.



●Equivalent-circuit diagram of the terminals

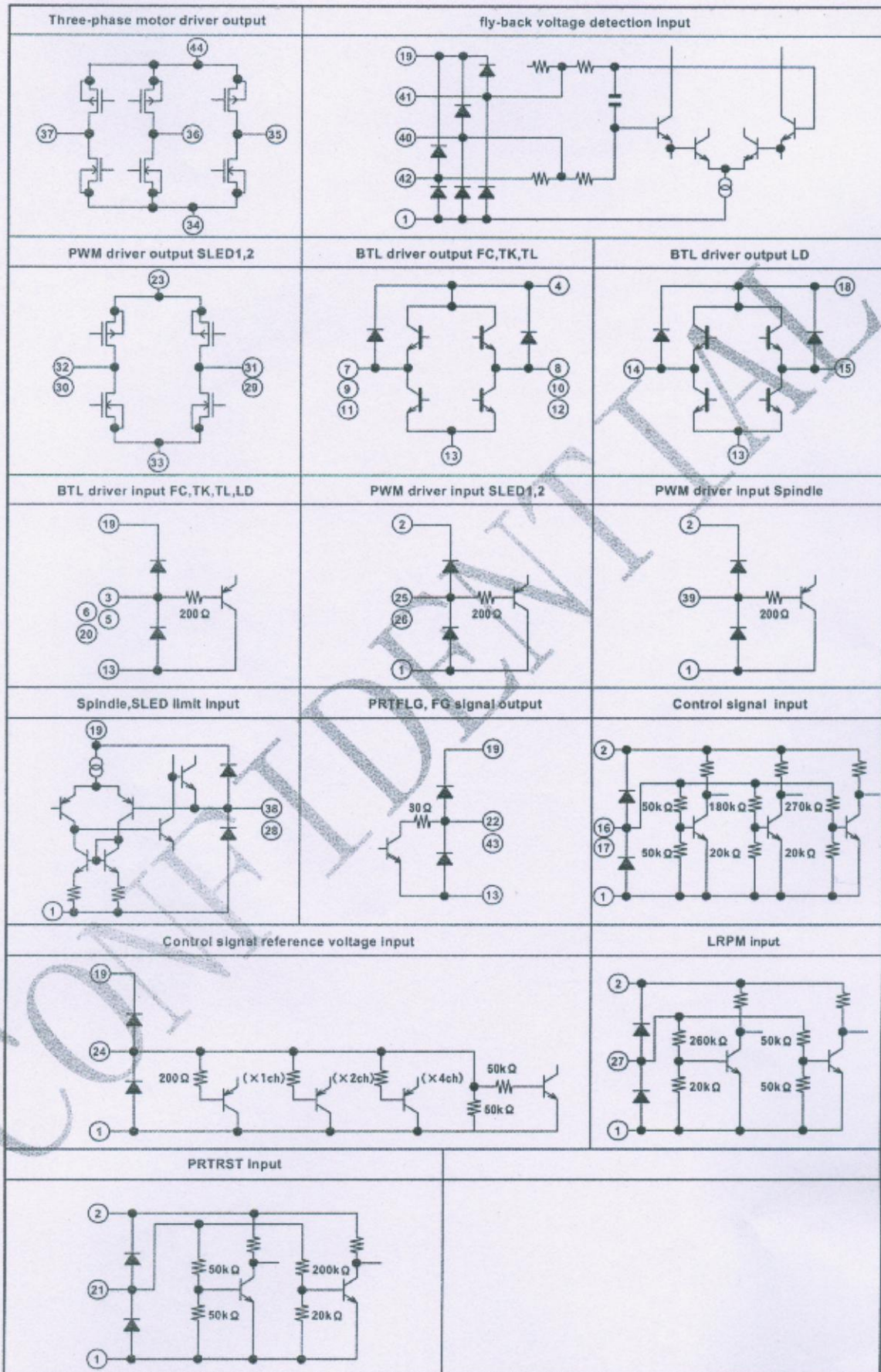



● Electrical characteristics (Unless otherwise noted, Ta=25°C, Vcc=SPVM=SLVM=12V, DVcc=AVM=LDVM=5V, Vc=1.65V, RL=8Ω, RLSP=2Ω)

Parameter	Symbol	MIN.	TYP.	MAX.	Unit	Condition
<b>Circuit current</b>						
Quiescent current 1	IQ1	—	11.5	25	mA	Vcc (Loading OFF)
Quiescent current 2	IQ2	—	6	12	mA	Vcc (Loading ON)
Quiescent current 3	IQ3	—	6	11	mA	DVcc
Standby-on current 1	IST1	—	0	100	μA	Vcc
Standby-on current 2	IST2	—	0	100	μA	DVcc
<b>Sled driver block</b>						
Input dead zone (one side)	VDZSL	0	30	80	mV	
Input output gain	gmSL	0.75	1.0	1.25	A/V	RSLIM=3.0kΩ
Output ON resistor (upper)	RONUSL	—	1.15	1.6	Ω	IL=500mA
Output ON resistor (lower)	RONLSL	—	1.05	1.4	Ω	IL=-500mA
Output limit current	ILIMSL	0.85	1.0	1.15	A	RSLIM=3.0kΩ
PWM frequency	fosc	—	100	—	kHz	
<b>Spindle driver block &lt;Torque control&gt;</b>						
Input dead zone (one side)1	VDZSP1	20	55	90	mV	VLRPM=L
Input dead zone (one side)2	VDZSP2	20	220	450	mV	VLRPM=H
Input output gain 'H'	gmSPH	2.3	3.0	3.7	A/V	VLRPM=L
Input output gain 'L'	gmSPL	0.46	0.6	0.74	A/V	VLRPM=H
Output ON resistor (upper)	RONUSP	—	0.35	0.55	Ω	IL=500mA
Output ON resistor (lower)	RONLSP	—	0.3	0.45	Ω	IL=-500mA
Output limit current	ILIMSP	—	—	—	A	RSPLIM=T.B.D.
PWM frequency	fosc	—	167	—	kHz	
<b>Spindle driver block &lt;FG output&gt;</b>						
High voltage	VFGH	—	4.9	—	V	100kΩ pull up to DVcc
Low voltage	VFGL	—	0.1	—	V	
<b>Focus driver block</b>						
Output offset voltage	VOFF	-20	0	20	mV	
Output saturation voltage 'H'	VOHF	—	0.3	0.7	V	IL=500mA
Output saturation voltage 'L'	VOLF	—	0.4	0.9	V	IL=-500mA
Voltage gain 'H'	GVF	19.6	21.6	23.6	dB	VLRPM=L
Voltage gain 'L'	GVF	13.6	15.6	17.6	dB	VLRPM=H
<b>Tracking driver block</b>						
Output offset voltage	VOFT	-20	0	20	mV	
Output saturation voltage 'H'	VOHT	—	0.3	0.7	V	IL=500mA
Output saturation voltage 'L'	VOLT	—	0.4	0.9	V	IL=-500mA
Voltage gain	GVT	19.6	21.6	23.6	dB	
<b>Tilt driver block</b>						
Output offset voltage	VOFTL	-50	0	50	mV	
Output saturation voltage 'H'	VOHTL	—	0.3	0.7	V	IL=500mA
Output saturation voltage 'L'	VOLT	—	0.4	0.9	V	IL=-500mA
Voltage gain 'H'	GVF	19.6	21.6	23.6	dB	VLRPM=L
Voltage gain 'L'	GVF	13.6	15.6	17.6	dB	VLRPM=H
<b>Loading driver block</b>						
Output offset voltage	VOFLD	-50	0	50	mV	
Output saturation voltage 1	VOLD1	—	0.6	1.6	V	IL=500mA LDVM=5V
Output saturation voltage 2	VOLD2	—	1.9	3.5	V	IL=500mA LDVM=12V
Voltage gain	GVLD	15.5	17.5	19.5	dB	
<b>CTL1,CTL2,LRPM</b>						
Input high voltage	VIH	2.0	—	3.7	V	
Input low voltage	VIL	—	—	0.5	V	
<b>Others</b>						
VC drop-muting	VMVC	0.4	0.7	1.0	V	
Vcc drop-muting	VMVcc	3.45	3.85	4.25	V	

\*This product is not designed to be radiation-resistant.



● Test circuit

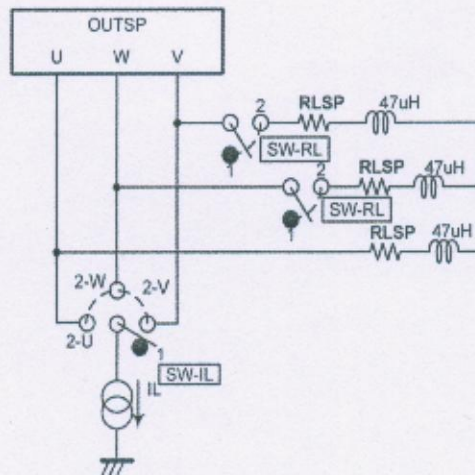
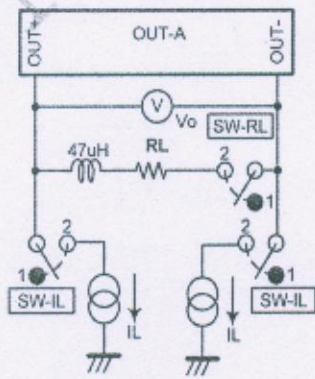
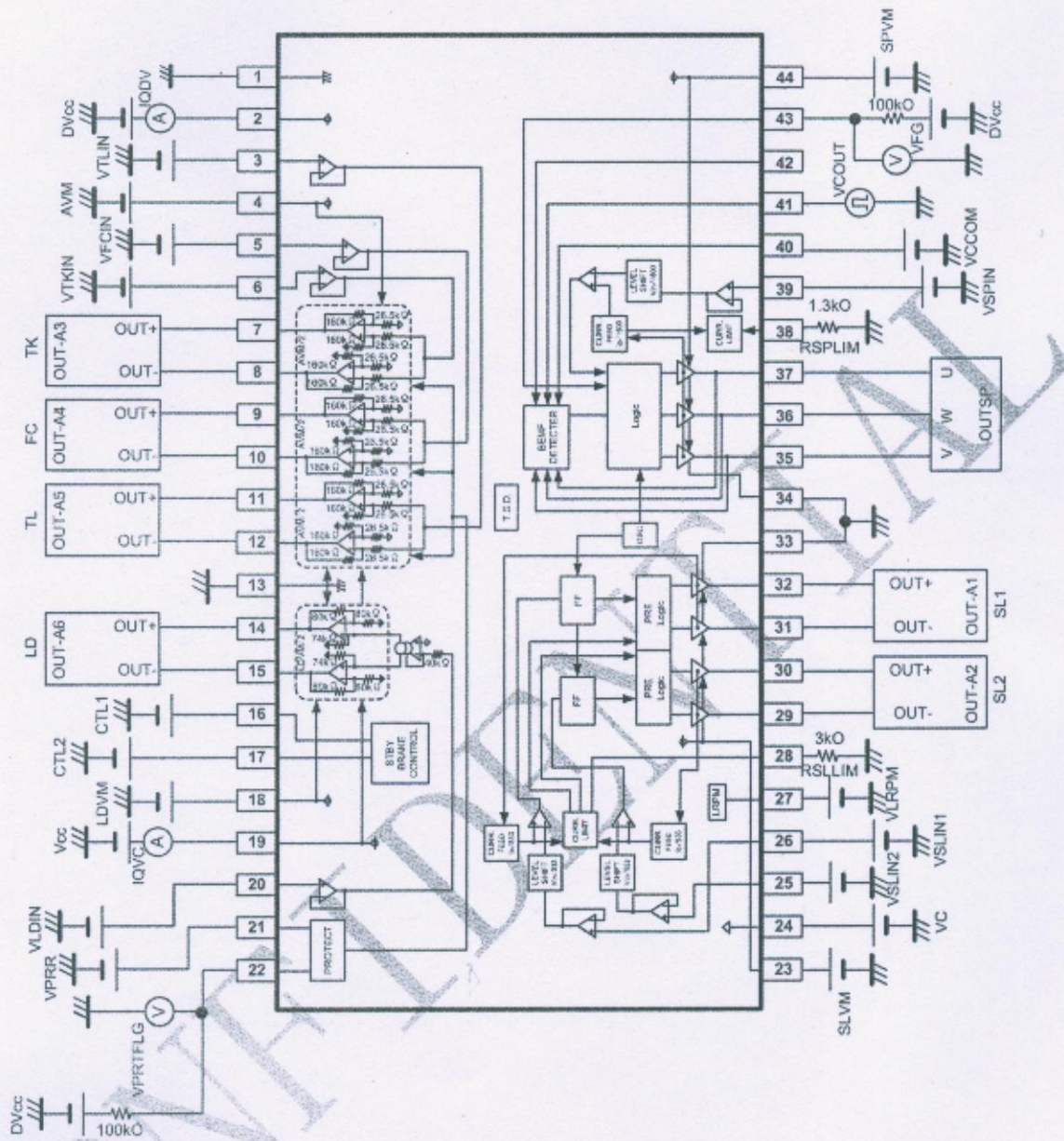



● Functional description

1-1 Driver control terminal 1 and 2 (CTL1,2)

All drivers and spindle-drive braking modes can be switched on/off by inputting combinations of H-level signal (higher than 2V) and L-level signal (lower than 0.5V) to these terminals.

CTL1	CTL2	Spindle	Sled	Focus	Tracking	Tilt	Loading	FG output
L	L	×	×	×	×	×	×	×
H	L	×	○	×	×	×	○	○
-	H	○	○	○	○	○	×	○

①  
②  
○:ON ×:OFF

CTL1	CTL2	SPIN > VC	SPIN < VC
L	H	Forward-rotation mode	Short-circuit braking mode
H	H	Forward-rotation mode	Reverse-rotation braking mode (LRPM=L)

\*Details of CTL1,2=H are shown in 1-2.

1-2. Spindle output mode

The spindle output changes as follows by the setting of LRPM and SPIN. (CTL1,2=High)

Rotation speed	0rpm	400rpm	4500rpm
Normal mode	SPIN>VC	120° energizing	150° energizing
LRPM=Low	SPIN<VC	120° energizing	150° energizing
			Short brake
LRPM mode	SPIN>VC	120° energizing	
LRPM=High	SPIN<VC	(H,Hi-Z,Hi-Z)	

\*PWM frequency become 30kHz (Typ.) in LRPM mode.

- ① Standby mode  
When the IC is in standby, its power dissipation can be limited.
- ② Drivers muting  
All output channels, except the loading and sled motor, are muted and their outputs are turned off.
- ③ Short-circuit braking mode (spindle)  
All the spindle driver outputs are shorted out to SPVM when SPIN < VC.
- ④ Reverse-rotation braking mode (spindle) (Only at LRPM=LOW)  
When SPIN < VC, all output are shorted to SPVM in 4500rpm (Typ.) or more, in less than 4500rpm (Typ.) the output become reverse-rotation braking mode.  
Rotation speed is less than 140rpm when SPIN < VC, all the output are shorted to SPVM.  
(However, the above-mentioned rotational speed is expressed in the case of 12pole motor.)
- ⑤ Low rotation mode  
Please make to low rotation mode (LRPM=HI) after it starts in normal mode (LRPM=L).

2. Output limit for spindle (SPLIM) /sled (SLLIM)

$$ILIMSP = \frac{A}{RSPLIM(O)} \quad (A) \quad A = T.B.D$$

$$ILIMSL = \frac{B}{RSLIM(O)} \quad (A) \quad B = 3000$$

3. Torque command/ output current detection terminals (SPIN) (SLIN1,2)

The relation between the torque command input and the output current detection terminals input is expressed in the figure below:

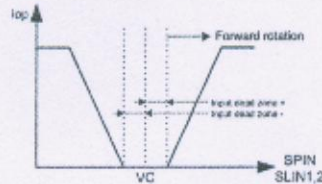

4. FG output (FG)

3FG output begins after 900° degrees in electric angle, after the start mode ends and the BEMF detection starts. When the rotational speed becomes 24rpm (Max.) or less in case of brake, the FG output is fixed to high. The above-mentioned rotation speed applies to the 12 pole motor.



● Functional description

5. Input/Output timing chart

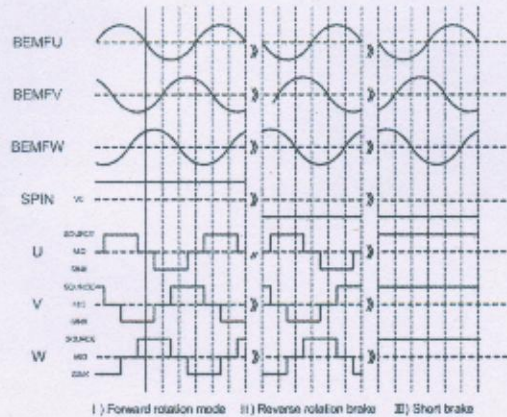

6. Protect system

The actuator protect system disables all output that exceeds 2.4s (Typ.) at maximum power.

PRTRST (INPUT)	Function	PRTFLG (OUTPUT)	Actuator output (FCO/TKO/TLO)
H	Disable	H	OFF
L	Enable	L	active

\*It is possible to reset the protect system not only PRTRST=Low but also CTL1,2=Low (Stand-by) in PRTRST=High and the protect operates.

	MIN.	TYP.	MAX.	Unit
Time until protection function operates	2.1	2.4	2.7	sec

7. Protection function 2

Function to protect against destruction of output terminal when output pin connects to GND or VCC. (The LDVM=12V is excluded.)

a) Content of protection operation. (Focus, Tracking, Tilt, and Loading)

- ① When SINK side POWER transistor has been turned on, if the output current (400mA<TYP> or more) and the output voltage (VCC-1V<TYP> or more) are detected, the channel concerned will be turned off.
- ② When SOURCE side POWER transistor has been turned on, if the output current (1.6A<TYP> or more) are detected, the channel concerned will be turned off.

b) Content of protection operation. (Spindle and sled motor)

- ① When SINK side POWER transistor has been turned on, if the output current (SPVM/2 & SLVM/2<TYP> or more) are detected, the channel concerned will be turned off.
- ② When SOURCE side POWER transistor has been turned on, if the output current (SPVM/2 & SLVM/2<TYP> or less) are detected, the channel concerned will be turned off.

8. PWM oscillation frequency

The PWM oscillation for driving the spindle and sled is free running.  
 The sled oscillating frequency is 100kHz (Typ.)  
 The spindle oscillating frequency is 167kHz (Typ.)

9. Muting functions

a) VC-drop muting

When the voltage at VC terminal drops to a value lower than 0.7V (Typ.), the outputs of all the channels are turned off.  
 Set the VC terminal voltage higher than 1.0V.

b) Vcc-drop muting

When the voltage at DVcc terminal and Vcc terminal drop to lower than 3.85V (Typ.), the outputs of all the channels are turned off.

c) Over voltage protection circuit

When the voltage at SPVM terminal exceed 14.1V (Typ.), only the spindle block output is turned off.

10. Thermal-shut down

Thermal-shutdown circuit (over-temperature protection circuit) is built in to prevent the IC from thermal breakdown. Use the IC according to the thermal loss allowed in the package. In case the IC is left running over the allowed loss, the junction temperature rises, and the thermal-shutdown of Spindle works at a junction temperature of 180°C(Typ.), and the thermal-shutdown of all other channel works at a junction temperature of 185°C(Typ.)  
 When the junction temperature drops to 170°C (Typ.) the IC except Spindle resumes operation, and when the junction temperature drops to 165°C (Typ.) all other channel resumes operation.



● Caution on use

1. Absolute maximum ratings

We are careful enough for quality control about this IC. So, there is no problem under normal operation, excluding that it exceeds the absolute maximum ratings. However, this IC might be destroyed when the absolute maximum ratings, such as impressed voltages ( $V_{cc}$ ,  $PV_{cc}$ ) or the operating temperature range ( $Topr$ ), is exceeded, and whether the destruction is short circuit mode or open circuit mode cannot be specified. Please take into consideration the physical countermeasures for safety, such as fusing, if a particular mode that exceeds the absolute maximum rating is assumed.

2. Power supply line

Due to switching and EMI noise generated by magnetic components (inductors and motors), using electrolytic and ceramic suppress filter capacitors ( $0.1\mu F$ ) close to the IC power input terminals ( $V_{cc}$  and GND) is recommended. Please note: the electrolytic capacitor value decreases at lower temperatures.

3. GND line

The ground line is where the lowest potential and transient voltages are connected to the IC.G

4. Thermal design

Do not exceed the power dissipation ( $Pd$ ) of the package specification rating under actual operation, and please design enough temperature margins.

5. Short circuit mode between terminals and wrong mounting

Do not mount the IC in the wrong direction and be careful about the reverse-connection of the power connector. Moreover, this IC might be destroyed when the dust short the terminals between them or GND

6. Radiation

Strong electromagnetic radiation can cause operation failures.

7. ASO (Area of Safety Operation.)

Do not exceed the maximum ASO and the absolute maximum ratings of the output driver.

8. TSD (Thermal shut-down)

The TSD of Spindle is activated when the junction temperature ( $Tj$ ) reaches  $175^{\circ}C$  (with  $\pm 15^{\circ}C$  hysteresis), the TSD of all other channel is activated when the junction temperature ( $Tj$ ) reaches  $185^{\circ}C$  (with  $\pm 15^{\circ}C$  hysteresis), and the output terminal is switched to Hi-z. The TSD circuit aims to intercept IC from high temperature. The guarantee and protection of IC are not purpose. Therefore, please do not use this IC after TSD circuit operates, nor use it for assumption that operates the TSD circuit.

9. Inspection by the set circuit board

The stress might hang to IC by connecting the capacitor to the terminal with low impedance. Then, please discharge electricity in each and all process. Moreover, in the inspection process, please turn off the power before mounting the IC, and turn on after mounting the IC. In addition, please take into consideration the countermeasures for electrostatic damage, such as giving the earth in assembly process, transportation or preservation.

10. Earth wiring pattern

This IC is a monolithic IC, and has P<sup>+</sup> isolation and P substrate for the element separation. Therefore, a parasitic PN junction is formed in this P-layer and N-layer of each element. For instance, the resistor or the transistor is connected to the terminal as shown in the figure below. When the GND voltage potential is greater than the voltage potential at Terminals A or B, the PN junction operates as a parasitic diode. In addition, the parasitic NPN transistor is formed in said parasitic diode and the N layer of surrounding elements close to said parasitic diode. These parasitic elements are formed in the IC because of the voltage relation. The parasitic element operating causes the wrong operation and destruction. Therefore, please be careful so as not to operate the parasitic elements by impressing to input terminals lower voltage than GND (P substrate). Please do not apply the voltage to the input terminal when the power-supply voltage is not impressed. Moreover, please impress each input terminal lower than the power-supply voltage or equal to the specified range in the guaranteed voltage when the power-supply voltage is impressing.

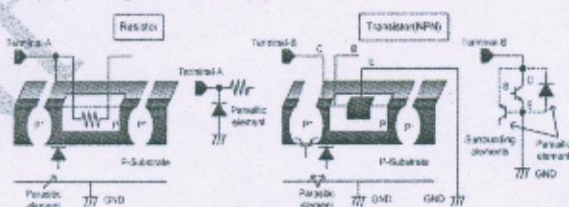

Simplified structure of IC

11. Earth wiring pattern

Use separate ground lines for control signals and high current power driver outputs. Because these high current outputs that flows to the wire impedance changes the GND voltage for control signal. Therefore, each ground terminal of IC must be connected at the one point on the set circuit board. As for GND of external parts, it is similar to the above-mentioned.

12. Reverse-rotation braking

In the case of reverse-rotation braking from high speed rotation, pay good attention to reverse electromotive force. Furthermore, fully check the voltage to be applied to the output terminal and consider the revolutions applied to the reverse-rotation brake.

13. About the capacitor between SPVM and SPGND

The capacitor between SPVM and SPGND absorbs the change in a steep voltage and the current because of the PWM drive, as a result, there is a role to suppress the disorder of the SPVM voltage. However, the effect falls by the influence of the wiring impedance etc, if the capacitor becomes far from IC. Please examine the capacitor between SPVM and SPGND to arrange it near IC.







● Package outlines

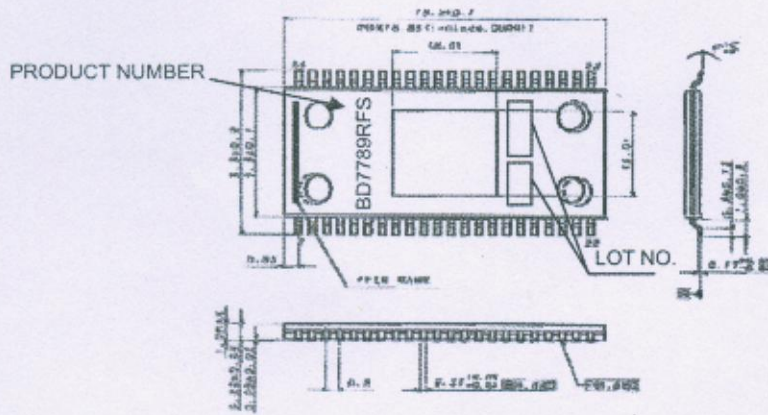

HTSSOP-A44R (UNIT : mm)

● Electrical characteristic curves

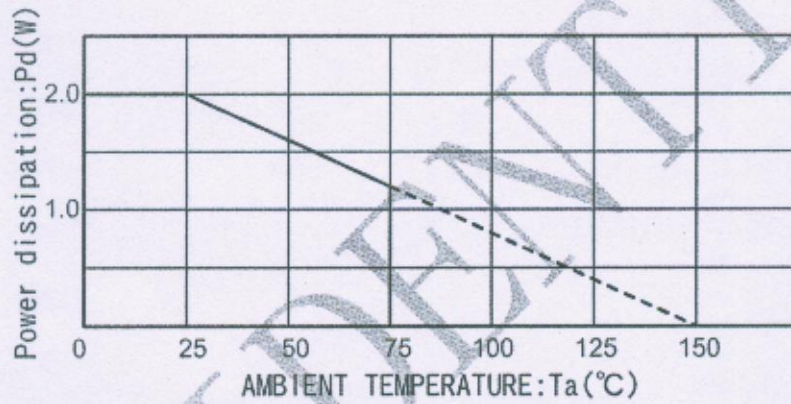

\*70mm×70mm, t=1.6mm, occupied copper foil is less than 3%, glass epoxy mounting.

CONFIDENTIAL