

EC²

space saver T²L



COMPATIBLE

FAST LOGIC DELAY MODULE

- T²L input and outputs
- Delays stable and precise
- 8-pin Space Saver package
- Leads - thru-hole, J, Gull Wing or Tucked
- Available in delays from 10 to 500ns
- Output and four (4) taps - each isolated and with 10 T²L fan-out capacity
- Fast rise time on all outputs

design notes

The "Space Saver Series" Logic Delay Modules developed by Engineered Components Company have been designed to provide precise delays with required driving and pick-off circuitry contained in a single 8-pin package compatible with FAST and Schottky T²L circuits. These logic delay modules are of hybrid construction utilizing the proven technologies of active integrated circuitry and of passive networks utilizing capacitive, inductive and resistive elements. The MTBF on these modules, when calculated per MIL-HDBK-217 for a 50°C ground fixed environment, is in excess of 2 million hours. Module design includes compensation for propagation delays and incorporates internal termination at the output; no additional external components are needed to obtain the desired delay.

The SSFLDM-TTL is offered in 33 delays from 10 to 500ns with each module incorporating total output and four (4) taps. Delay tolerances are maintained as shown in the accompanying part number table, when tested under the "Test Conditions" shown. Delay time is measured at the +1.5V level on the leading edge.

Rise time for all modules is 4ns maximum when measured from 0.8V to 2.0V. Temperature coefficient of delay is approximately +500 ppm/°C over the operating temperature range of 0 to +70°C.

These modules accept either logic "1" or logic "0" inputs and reproduce the logic at the output without inversion. The delay modules are intended primarily for use with positive going pulses and are calibrated to the tolerances shown in the table on rising edge delay; where best accuracy is desired in applications using falling edge timing, it is recommended that a special unit be calibrated for the specific application. Each module has the capability of driving up to 20 Schottky T²L loads with a maximum of 10 loads on any one tap.

These "Space Saver Series" modules are packaged in an 8-pin housing, molded of flame-proof Diallyl Phthalate per MIL-M-14, Type SDG-F, and are fully encapsulated in epoxy resin. Thru-hole, J, Gull Wing or Tucked Lead configurations are available on these modules (see Part Number Table note to specify). Leads meet the solderability requirements of MIL-STD-202, Method 208. Corner standoffs on the housing of the thru-hole lead version and lead design of the surface mount versions provide positive standoff from the printed circuit board to permit solder-fillet formation and flush cleaning of solder-flux residues for improved reliability.

Marking consists of manufacturer's name, logo (EC²), part number, terminal identification and date code of manufacture. All marking is applied by silk screen process using white epoxy paint in accordance with MIL-STD-130, to meet the permanency of identification required by MIL-STD-202, Method 215.

EC²

engineered components company

3580 Sacramento Drive, P.O. Box 8121, San Luis Obispo, CA 93403-8121

Phone: (805) 544-3800

BLOCK DIAGRAM IS SHOWN BELOW

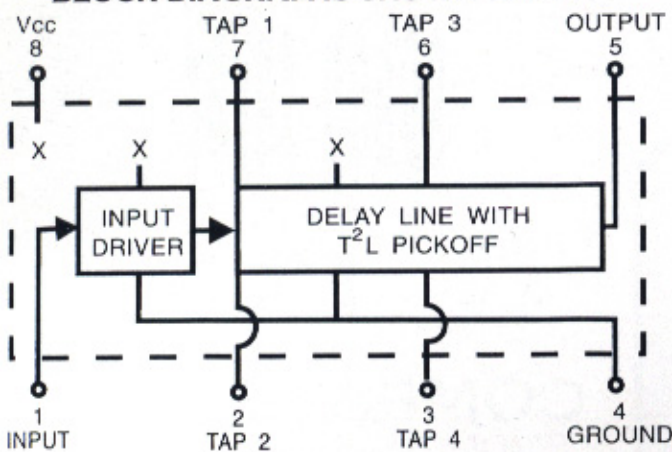

MECHANICAL DETAIL IS SHOWN BELOW

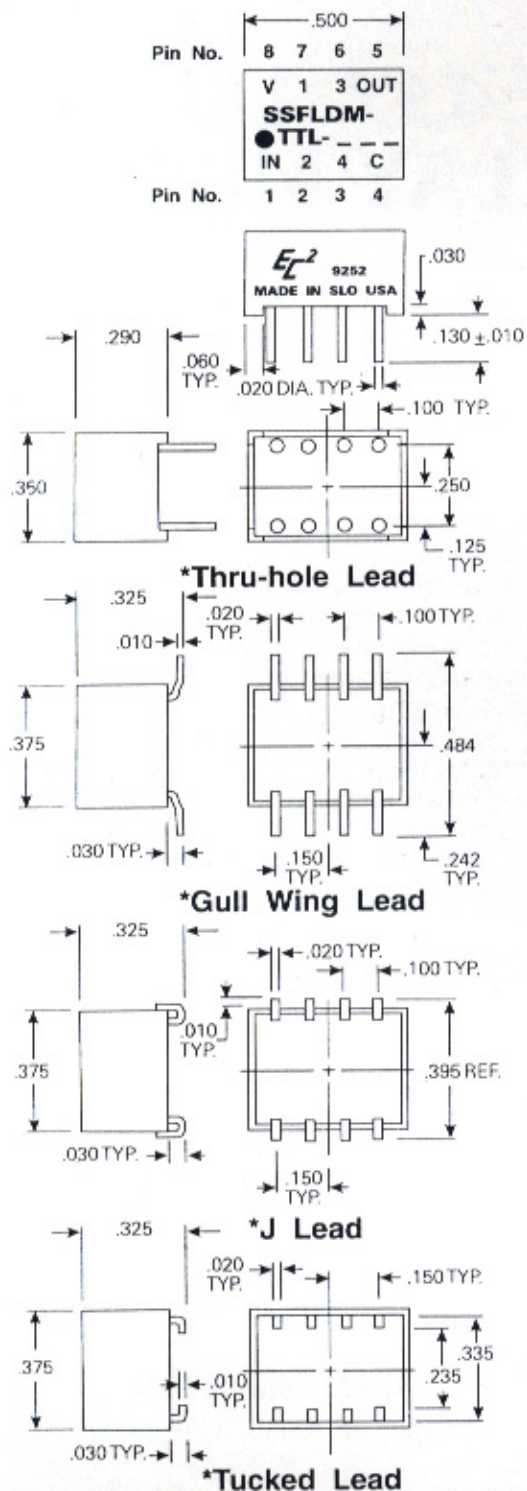

TEST CONDITIONS

1. All measurements are made at 25°C.
2. V_{cc} supply voltage is maintained at 5.0V DC.
3. All units are tested using a Schottky toggle-type positive input pulse and one Schottky load at the output being tested.
4. Input pulse width used is 5 to 10ns longer than delay of module under test; spacing between pulses (falling edge to rising edge) is three times the pulse width used.

OPERATING SPECIFICATIONS

- * V_{cc} supply voltage: 4.75 to 5.25V DC
- V_{cc} supply current;
 - Constant "0" in **40mA typical**
 - Constant "1" in **7mA typical**
- Logic 1 Input:
 - Voltage 2V min.; V_{cc} max.
 - Current 2.7V = 20uA max.
 - 5.5V = 1mA max.
- Logic 0 Input:
 - Voltage8V max.
 - Current -.6mA max.
- Logic 1 Voltage out: 2.7V min.
- Logic 0 Voltage out:5V max.
- Operating temperature range: 0 to 70°C
- Storage temperature: -55 to +125°C.

* Delays increase or decrease approximately 2% for a respective increase or decrease of 5% in supply voltage.

PART NUMBER TABLE

*Suffix Part Number with G (for Gull Wing Lead), J (for J Lead), F (for Thru-hole Lead) or T (for Tucked Lead). Examples: SSFLDM-TTL-10G (Gull Wing), SSFLDM-TTL-25J (J Lead), SSFLDM-TTL-75F (Thru-hole Lead) or SSFLDM-TTL-12T (Tucked Lead).

∅ DELAYS AND TOLERANCES (in ns)					
PART NO.	TAP 1	TAP 2	TAP 3	TAP 4	OUTPUT
SSFLDM-TTL-10	6 ±1	7 ±1	8 ±1	9 ±1	10 ±1
SSFLDM-TTL-12	6 ±1	7.5 ±1	9 ±1	10.5 ±1	12 ±1
SSFLDM-TTL-14	6 ±1	8 ±1	10 ±1	12 ±1	14 ±1
SSFLDM-TTL-16	6 ±1	8.5 ±1	11 ±1	13.5 ±1	16 ±1
SSFLDM-TTL-18	6 ±1	9 ±1	12 ±1	15 ±1	18 ±1
SSFLDM-TTL-22	6 ±1	10 ±1	14 ±1	18 ±1	22 ±1
SSFLDM-TTL-25	5 ±1	10 ±1	15 ±1	20 ±1	25 ±1
SSFLDM-TTL-30	6 ±1	12 ±1	18 ±1	24 ±1	30 ±1
SSFLDM-TTL-35	7 ±1	14 ±1	21 ±1	28 ±1.5	35 ±1.5
SSFLDM-TTL-40	8 ±1	16 ±1	24 ±1.5	32 ±1.5	40 ±1.5
SSFLDM-TTL-45	9 ±1	18 ±1	27 ±1.5	36 ±1.5	45 ±2
SSFLDM-TTL-50	10 ±1	20 ±1	30 ±1.5	40 ±2	50 ±2
SSFLDM-TTL-55	11 ±1	22 ±1	33 ±1.5	44 ±2	55 ±2
SSFLDM-TTL-60	12 ±1	24 ±1	36 ±1.5	48 ±2	60 ±2
SSFLDM-TTL-65	13 ±1	26 ±1.5	39 ±1.5	52 ±2	65 ±2.5
SSFLDM-TTL-70	14 ±1	28 ±1.5	42 ±2	56 ±2	70 ±2.5
SSFLDM-TTL-75	15 ±1	30 ±1.5	45 ±2	60 ±2.5	75 ±2.5
SSFLDM-TTL-80	16 ±1	32 ±1.5	48 ±2	64 ±2.5	80 ±3
SSFLDM-TTL-85	17 ±1	34 ±1.5	51 ±2	68 ±2.5	85 ±3
SSFLDM-TTL-90	18 ±1	36 ±1.5	54 ±2	72 ±2.5	90 ±3
SSFLDM-TTL-95	19 ±1	38 ±1.5	57 ±2	76 ±2.5	95 ±3
SSFLDM-TTL-100	20 ±1	40 ±1.5	60 ±2	80 ±3	100 ±3
SSFLDM-TTL-125	25 ±1	50 ±2	75 ±2.5	100 ±3	125 ±4
SSFLDM-TTL-150	30 ±1.5	60 ±2	90 ±3	120 ±4	150 ±5
SSFLDM-TTL-175	35 ±1.5	70 ±2.5	105 ±4	140 ±5	175 ±5
SSFLDM-TTL-200	40 ±1.5	80 ±2.5	120 ±4	160 ±5	200 ±6
SSFLDM-TTL-225	45 ±2	90 ±3	135 ±4	180 ±6	225 ±7
SSFLDM-TTL-250	50 ±2	100 ±3	150 ±4.5	200 ±6	250 ±8
SSFLDM-TTL-300	60 ±2	120 ±4	180 ±5	240 ±7	300 ±9
SSFLDM-TTL-350	70 ±2	140 ±4.5	210 ±7	280 ±9	350 ±11
SSFLDM-TTL-400	80 ±3	160 ±5	240 ±7	320 ±10	400 ±12
SSFLDM-TTL-450	90 ±3	180 ±6	270 ±8	360 ±11	450 ±14
SSFLDM-TTL-500	100 ±3	200 ±6	300 ±9	400 ±12	500 ±15

∅ All modules can be operated with a minimum input pulse width of 40% of full delay and pulse period approaching square wave; since delay accuracies may be somewhat degraded, it is suggested that the module be evaluated under the intended specific operating conditions. Special modules can be readily manufactured to improve accuracies and/or provide customer specified random delay times for specific applications.