

PRODUCT NUMBER
SEE NOTE 1

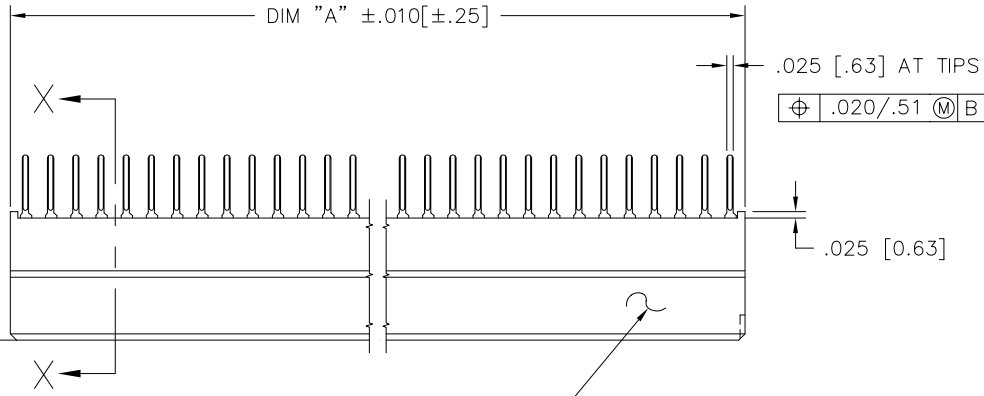

NOTE 6

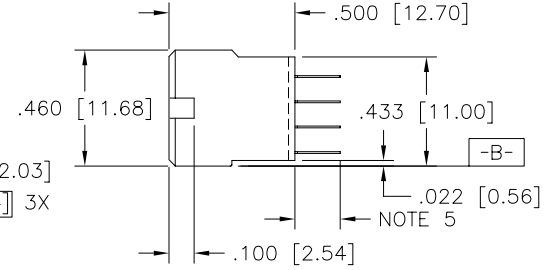
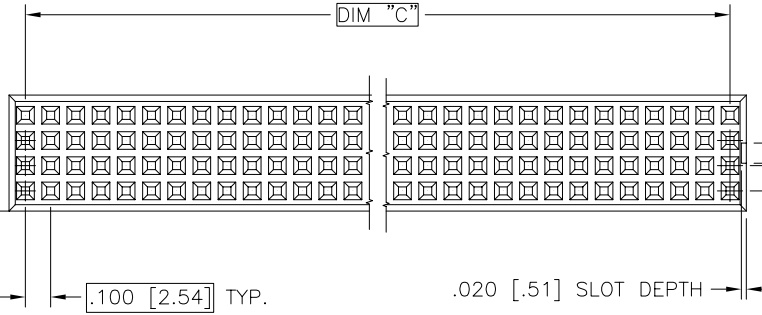

FCIconnect.com

Copyright FCI

mat'l. code				surface ISO 1302 <input checked="" type="checkbox"/>		tolerance ISO 406 ISO 1101		projection 		product family HPC	
tolerances unless otherwise specified				angles		linear		INCH/MM		title	
A	V60155	GIP	1/24/96			.XX±.01/.3				4 ROW VERTICAL RECEPTACLE SPECIAL ASSEMBLY	
B	V92836	HTB	9/15/99			.xxx±.005/.13				dwg no	
C	V94346	HTB	11/18/99	0°±2'		.xxxx±.0020/.05		scale 1:1		sheet 1 of 2 size	
D	V00258	JWS	1/21/00	dr	G.PETERS	1/24/96				50939	
E	M06-0260	MHT	7/07/06	enfr	R.MARSHALL	1/23/96				A3	
				chr	R.MARSHALL	1/23/96				type Product Customer Drawing	
				appd	S.CLARK	1/23/96					
sheet index	revision sheet	E	E								
		1	2								

form: A3

PRODUCT NUMBER		LENGTH FORMULAS
SEE NOTE 1	DIM A	.100/2.54 X NO. OF COLUMNS + .03/.8
	DIM C	.100/2.54 X NO. OF COLUMNS - .100/2.54

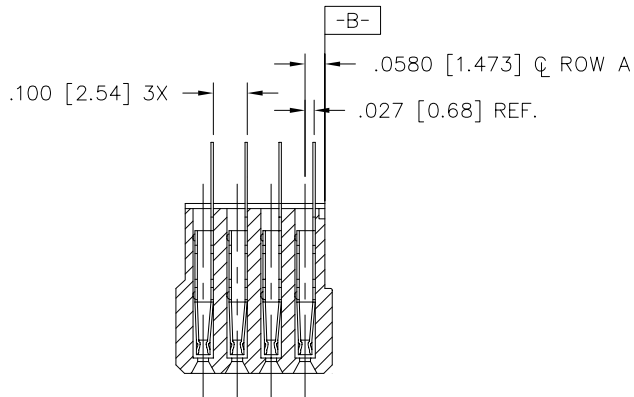

SECTION X-X
(SCALE: 2:1)

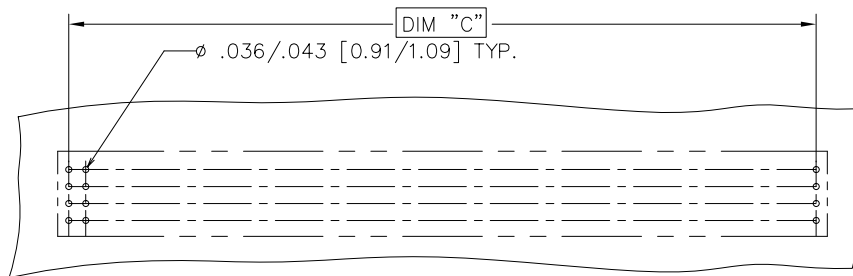

RECOMMENDED PCB LAYOUT
ALL HOLES LOCATED ON .100/2.54 GRID
UNLESS OTHERWISE SPECIFIED

NOTES:

- ① PRODUCT NUMBERING CODE:
50939 - X YYY Z
 - TAIL LENGTH (NOTE 5)
 - NO OF POSITIONS(NOTE 2)
 - PLATING (NOTE 4)
 - BASE NUMBER
- ② THIS PRODUCT IS CONFIGURED IN SIZES OF 10 THRU 80 COLUMNS IN INCREMENTS OF ONE.
IE: 10,11,12,13,.....79,80.
- ③ HOUSING MAT'L: GLASS AND MINERAL FILLED HIGH TEMP. THERMOPLASTIC. FLAME RETARDANT PER UL94V-0. COLOR: BLACK.
CONTACT MAT'L: BeCu
- ④ PLATING, CONTACT AREA OPTIONS:
1 = 30u"/.76u GOLD
3 = 50u"/1.27u GOLD
5 = 30u"/.76u GXT
ALL SOLDER TAILS TIN/LEAD.
- ⑤ TAIL LENGTH OPTIONS:
E = .125 ±.010 / 3.18 ±.25
F = .145 ±.010 / 3.68 ±.25
H = .180 ±.010 / 4.57 ±.25
- ⑥ MANUFACTURER'S NAME, P/N AND LOT CODE TO APPEAR ON THIS SURFACE PER BUS-12-108
7. FOR DOCUMENTATION MENU, SEE SPECIFICATION BUS-01-057.

mat'l. code		surface ISO 1302 ✓	tolerance ISO 406 ISO 1101	projection ⊕	product family HPC
ltr	ecn	no	dr	date	tolerances unless otherwise specified
					angles linear .xx±.01/.3
					linear .xxx±.005/.13
					0'±2' .xxxx±.0020/.05
			dr	G.PETERS	1/24/96
			enr	R.MARSHALL	1/23/96
			chr	R.MARSHALL	1/23/96
			appd	S.CLARK	1/23/96
sheet	revision				
index	sheet				
					INCH/MM scale 1:1
					title 4 ROW VERTICAL RECEPTACLE SPECIAL ASSEMBLY
					dwg no 50939
					sheet 2 of 2 size A3
					type Product Customer Drawing

FCI
FCIconnect.com
Copyright FCI