

LR8555

Low noise 150mA LDO regulator

LR8555 series is a group of positive voltage output Low power consumption, low dropout voltage regulator.

LR8555 can provide output value in the range of 1.2~5V every 0.1V step. It also can be customized on command.

LR8555 includes high accuracy voltage reference, error amplifier, current limit circuit and output driver module.

LR8555 has excellent load and line transient response and good temperature characteristics, which can assure the stability of chip and power system. And it uses trimming technique to output voltage accuracy with $\pm 2\%$.

LR8555 is available in SOT23-5, SC70-5 packages which is lead free. It also can be available in these packages with lead.

Feature :

- Low Power Consumption: 25uA (Typ.)
- Low output noise (27uVRMS)
- Standby Mode: 0.1uA
- Low dropout **Voltage**: 0.2V@100mA (Typ.)
- High Ripple Rejection: 65dB@1kHz (Typ.)
- Low Temperature Coefficient: $\pm 100\text{ppm}/^\circ\text{C}$
- Excellent Line regulation: 0.05%/V
- Build-in chip enable circuit
- Output **Voltage** Range: 1.2V~5.0V (customized on command every 0.1V step)
- Highly Accurate: $\pm 2\%$ ($\pm 1\%$ customized)
- Output Current Limit

Application :

- Power source for Cellular phones and various kind of PCSs
- Battery Powered equipment
- Power Management of MP3, PDA, DSC, Mouse, PS2 Games
- Reference Voltage Source
- Regulation after Switching Power

LR8555 Typical Application Circuit

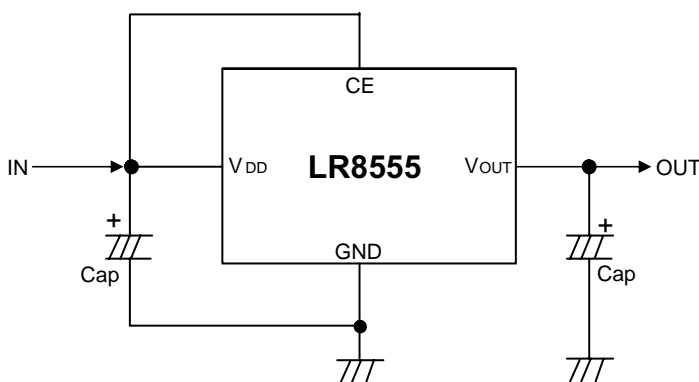

LR8555 Typical Performance Characteristic :

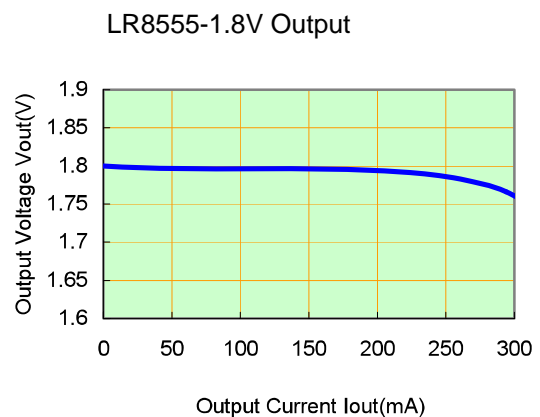

Selection Guide:

LR8555-XX X X

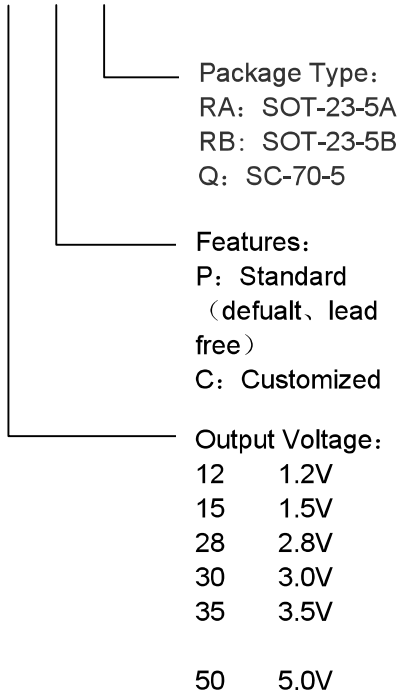

Pin Alignment :

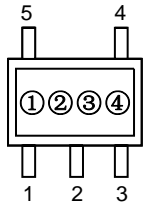
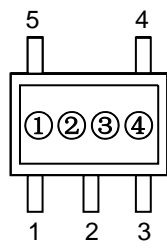
Product Classification	Assembly type & Pin Configuration
LR8555-□□PQ	SC70-5 
LR8555-□□PRA LR8555-□□PRB	SOT23-5 

Pin Delcription :

Pin Number			Symbol	Function
SC-70-5	SOT-23-5A	SOT-23-5B		
5	5	1	VOUT	Output pin
1	1	3	VDD	Input Pin
2	2	2	GND	Ground Pin
3	3	4	CE	Chip Enable Pin
4	4	5	NC	No Connection

Product Clallification :

Output Voltage	Pakgake Type	Produgt Name	Pakgake Type	Produgt Name	Pakgake Type	Produgt Name
1.2V	SOT-23-5A	LR8555-12PRA	SOT-23-5B	LR8555-12PRB	SC-70-5	LR8555-12PQ
1.5V	SOT-23-5A	LR8555-15PRA	SOT-23-5B	LR8555-15PRB	SC-70-5	LR8555-15PQ
1.8V	SOT-23-5A	LR8555-18PRA	SOT-23-5B	LR8555-18PRB	SC-70-5	LR8555-18PQ
2.1V	SOT-23-5A	LR8555-21PRA	SOT-23-5B	LR8555-21PRB	SC-70-5	LR8555-21PQ
2.5V	SOT-23-5A	LR8555-25PRA	SOT-23-5B	LR8555-25PRB	SC-70-5	LR8555-25PQ
2.8V	SOT-23-5A	LR8555-28PRA	SOT-23-5B	LR8555-28PRB	SC-70-5	LR8555-28PQ
3.0V	SOT-23-5A	LR8555-30PRA	SOT-23-5B	LR8555-30PRB	SC-70-5	LR8555-30PQ
3.2V	SOT-23-5A	LR8555-32PRA	SOT-23-5B	LR8555-32PRB	SC-70-5	LR8555-32PQ
3.3V	SOT-23-5A	LR8555-33PRA	SOT-23-5B	LR8555-33PRB	SC-70-5	LR8555-33PQ
3.5V	SOT-23-5A	LR8555-35PRA	SOT-23-5B	LR8555-35PRB	SC-70-5	LR8555-35PQ
⋮	⋮	⋮	⋮	⋮	⋮	⋮
5.0V	SOT-23-5A	LR8555-50PRA	SOT-23-5B	LR8555-50PRB	SC-70-5	LR8555-50PQ

Product Marking information:

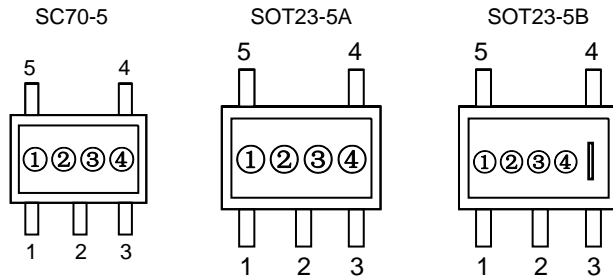

- ① Output current & EN availability
- ② Output voltage
- ③ Year of manufacturing
- ④ Week of manufacturing

①

Code	Iout	EN	Code	Iout	EN
A	50mA	No	\bar{A}	50mA	Yes
B	100mA	No	\bar{B}	100mA	Yes
C	150mA	No	\bar{C}	150mA	Yes
D	200mA	No	\bar{D}	200mA	Yes
E	250mA	No	\bar{E}	250mA	Yes
F	300mA	No	\bar{F}	300mA	Yes
G	350mA	No	\bar{G}	350mA	Yes
H	400mA	No	\bar{H}	400mA	Yes
I	450mA	No	\bar{I}	450mA	Yes
J	500mA	No	\bar{J}	500mA	Yes

②

Code	Vout	Code	Iout	Code	Iout
$\bar{2}$	1.2V	$\bar{7}$	2.7V	$\bar{2}$	4.2V
$\bar{3}$	1.3V	$\bar{8}$	2.8V	$\bar{3}$	4.3V
$\bar{4}$	1.4V	$\bar{9}$	2.9V	$\bar{4}$	4.4V
$\bar{5}$	1.5V	$\bar{0}$	3.0V	$\bar{5}$	4.5V
$\bar{6}$	1.6V	$\bar{1}$	3.1V	$\bar{6}$	4.6V
$\bar{7}$	1.7V	$\bar{2}$	3.2V	$\bar{7}$	4.7V
$\bar{8}$	1.8V	$\bar{3}$	3.3V	$\bar{8}$	4.8V
$\bar{9}$	1.9V	$\bar{4}$	3.4V	$\bar{9}$	4.9V
$\bar{0}$	2.0V	$\bar{5}$	3.5V	$\bar{0}$	5.0V
$\bar{1}$	2.1V	$\bar{6}$	3.6V		
$\bar{2}$	2.2V	$\bar{7}$	3.7V		
$\bar{3}$	2.3V	$\bar{8}$	3.8V		
$\bar{4}$	2.4V	$\bar{9}$	3.9V		
$\bar{5}$	2.5V	$\bar{0}$	4.0V		
$\bar{6}$	2.6V	$\bar{1}$	4.1V		

For example:

LR8555 with output current 150mA, SOT23-5 package with an EN pin its position ① is \bar{C}

- ③ The year of manufacturing: "5" stands for year 2005, "6" stands for year 2006, and "0" for year 2010.

④

Code	Week of Mfg	Code	Week of Mfg	Code	Week of Mfg	Code	Week of Mfg	Code	Week of Mfg
A	1	L	12	W	23	\bar{H}	34	\bar{S}	45
B	2	M	13	X	24	\bar{I}	35	\bar{T}	46
C	3	N	14	Y	25	\bar{J}	36	\bar{U}	47
D	4	O	15	Z	26	\bar{K}	37	\bar{V}	48
E	5	P	16	\bar{A}	27	\bar{L}	38	\bar{W}	49
F	6	Q	17	\bar{B}	28	\bar{M}	39	\bar{X}	50
G	7	R	18	\bar{C}	29	\bar{N}	40	\bar{Y}	51
H	8	S	19	\bar{D}	30	\bar{O}	41	\bar{Z}	52
I	9	T	20	\bar{E}	31	\bar{P}	42		
J	10	U	21	\bar{F}	32	\bar{Q}	43		
K	11	V	22	\bar{G}	33	\bar{R}	44		

Block Diagram:

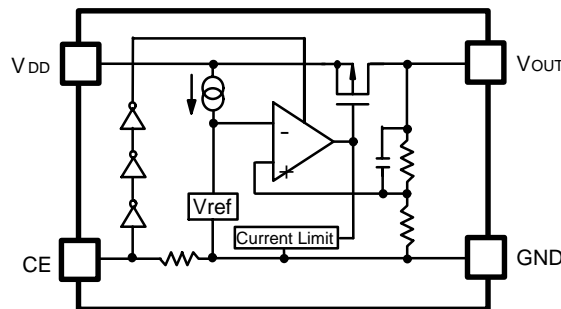

Absolute Maximum Ratingl :

Max input voltage -----	10V
Junction Temperature (Tj) -----	125°C
Output Current -----	200mA
Power Dissipation	
SOT-23-5 -----	200mW
SC-70-5 -----	200mW
Storage Temperature(Ts) -----	-45°C~150°C
Lead Temperature and Time -----	260°C, 10S

Recommended Work Conditionl :

Item	Min	Recommended	Max	unit
Input Voltage Range			8	V
Ambient Temperature	-40		85	°C

Electrical Characterilticl :

(Test Conditions: Cin=1uF,Cout=2.2uF,TA=25°C, unless otherwise specified.)

LR8555, for arbitrary output voltage

Symbol	Parameter	Conditionl	Min	Typ	Max	Unitl
Vin	Input Voltage		1.8		8	V
Vout	Output Voltage	Vin=Set Vout+1V 1mA≤Iout≤30mA	Vout x0.98		Vout X1.02	V
Iout (Max.)	Maximun Output Current	Vin-Vout=1V	150			mA
Dropout Voltage	Input-Output Voltage Differentia	Refer to the ELECTRICAL CHARACTERISTICS by OUTPUT VOLTAGE				
$\frac{\Delta V_{OUT}}{\Delta V_{IN} \cdot V_{OUT}}$	Line Regulation	Iout=40mA 1.6V≤Vin≤8V		0.05	0.2	%/V
$\Delta V_{OUT} / \Delta I_{OUT}$	Load Regulation	Vin=Set Vout+1V 1mA≤Iout≤80mA		12	40	mV
I _{ss}	Supply Current	Vin=Set Vout+1V		25	50	uA
I _{standby}	Supply Current (Srandby)	Vin=Set Vout+1V Vce=Gnd		0.1	1.0	uA
$\frac{\Delta V_{OUT}}{\Delta T \cdot V_{OUT}}$	Output Voltage Temperature Coefficiency	Iout=30mA		±100		ppm/°C
PSRR	Ripple Rejection	F=1kHz, Ripple=0.5Vp-p Vin=Set Vout+1V		65		dB
LLim	Short Current Limit	Vout=0V		20		mA
Rpd	CE Pull down Resistance		2.0	5.0	10.0	MΩ
Vceh	CE Input Voltage “H”		1.5		Vin	V
Vcel	CE Input Voltage “L”		0		0.25	V
en	Output Noise	BW=10Hz~100kHz		27		uVrms

Electrical Characteristic by Output Voltage

Output Voltage Vout (V)	Dropout Voltage, V _{DIF} (V)		
	Condition	Typ.	Max.
Vout = 1.5V	I _{out} = 120mA	0.38	0.70
Vout = 1.6V		0.36	0.65
Vout = 1.7V		0.34	0.60
1.8 ≤ Vout ≤ 2.0		0.32	0.55
2.1 ≤ Vout ≤ 2.7		0.28	0.50
2.8 ≤ Vout ≤ 4.0		0.22	0.35

Typical Application Circuit:

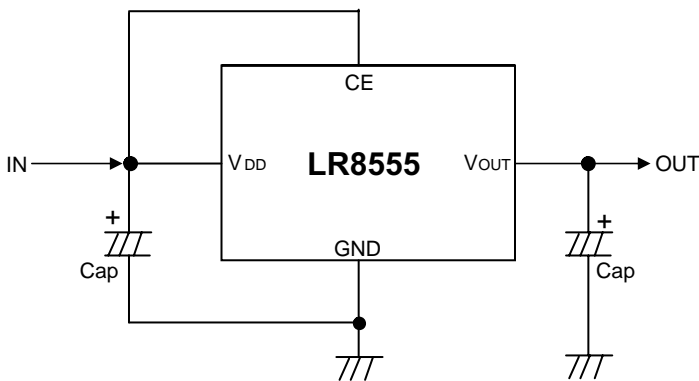

Application hint :

NOTE1: Input capacitor (C_{in}=1uF) is recommended in all application circuit.

NOTE2: Output capacitor (C_{out}=1uF/2.2uF) is recommended in all application to assure the stability of circuit.

Typical Performance Characterilticl :

1) Output Voltage vl. Output Current (with output lhort protection)

LR8555-1.8V

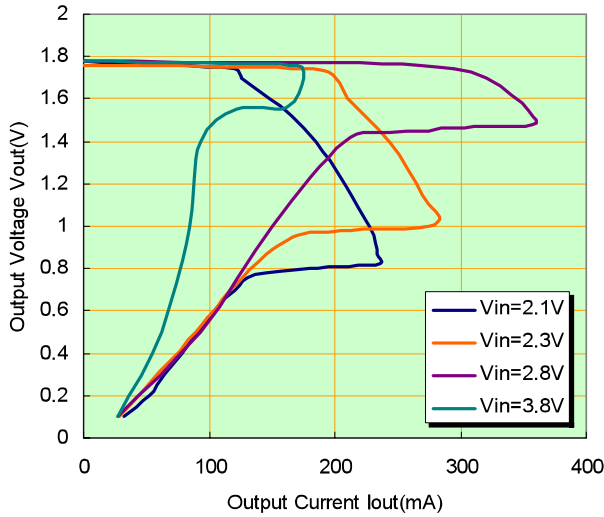

2) Output Voltage vl. Input Voltage

LR8555-1.8V

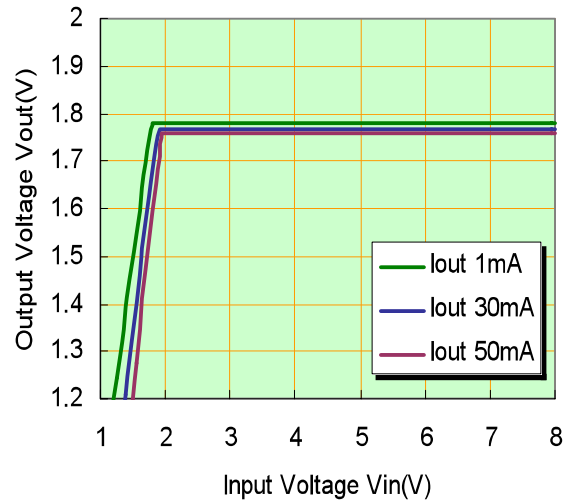

3) Dropout Voltage vl. Output Current

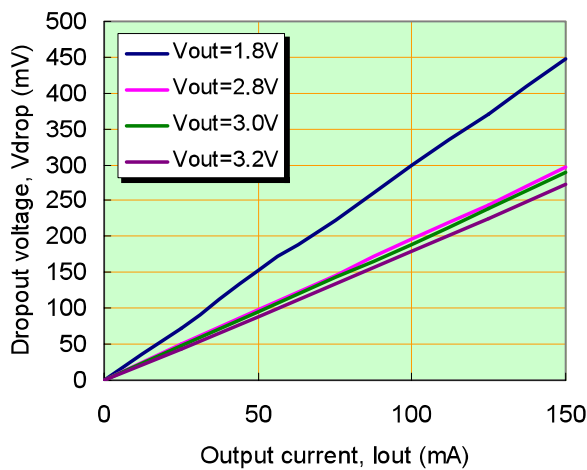

4) Supply Current vl. Input Voltage

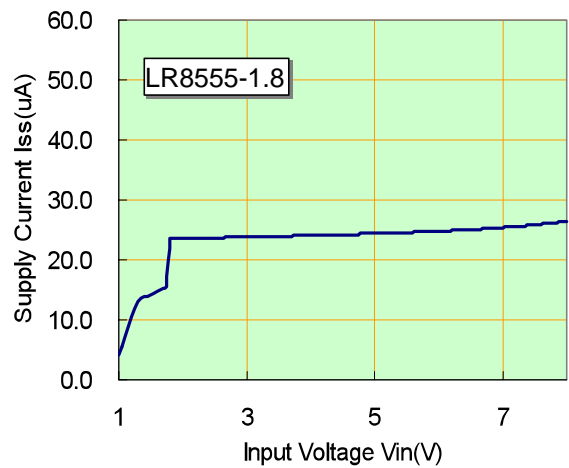

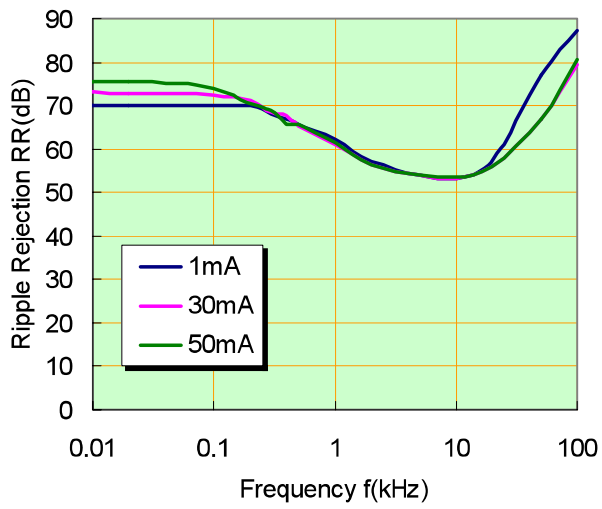
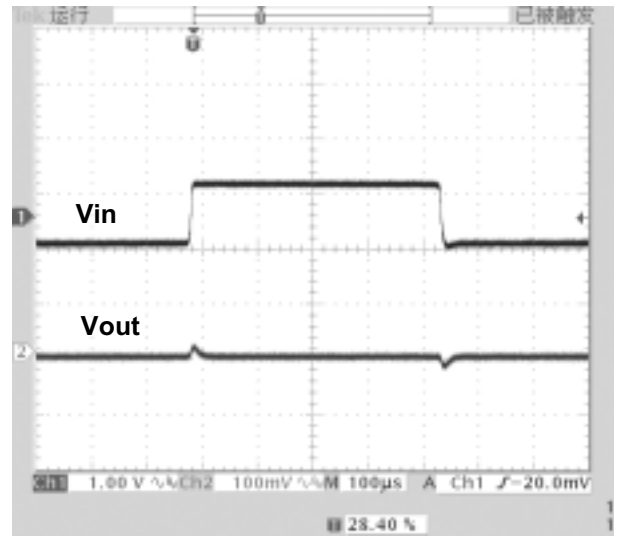
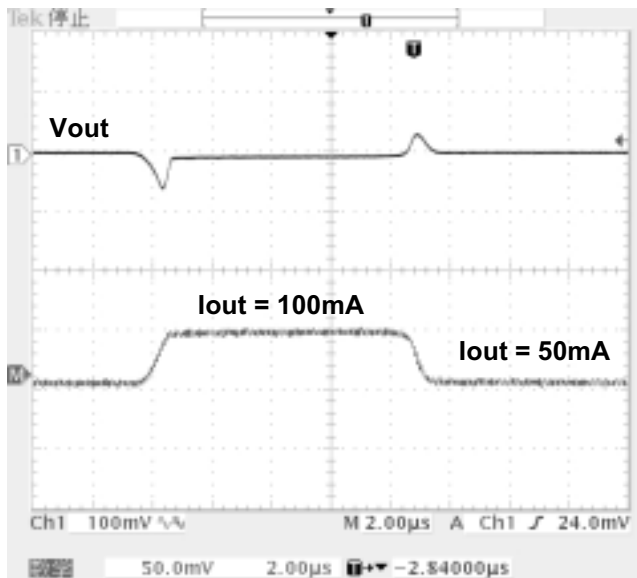
5) Ripple rejection vl. Frequency

6) Line tranlient relponle

7) Load tranlient relponle

SOT23-5

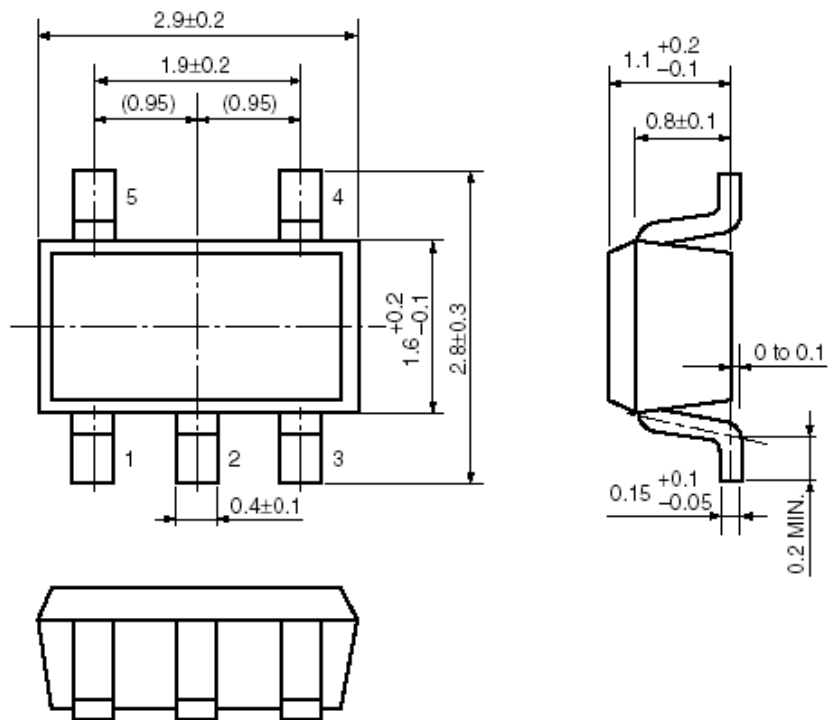
Package specification:

Unit: mm



SC70-5

NOTES:

1. DIMENSIONING AND TOLERANCING PER ANSI Y14.5M, 1982.
2. CONTROLLING DIMENSION: MILLIMETERS.

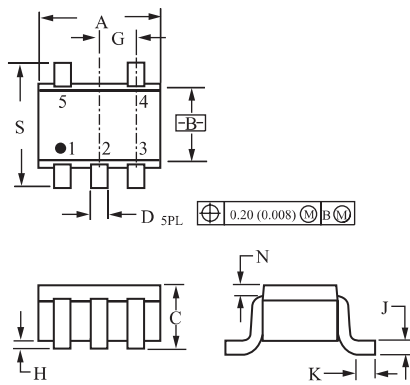

DIM	MILLIMETERS		INCHES	
	MIN	MAX	MIN	MAX
A	1.80	2.20	0.071	0.087
B	1.15	1.35	0.045	0.053
C	0.80	1.10	0.031	0.043
D	0.10	0.30	0.004	0.012
G	0.65 BSC		0.026 BSC	
H	—	0.10	—	0.004
J	0.10	0.25	0.004	0.010
K	0.10	0.30	0.004	0.012
N	0.20 REF		0.008 REF	
S	2.00	2.20	0.079	0.087