

# SBH 1520S ... SBH 1545S

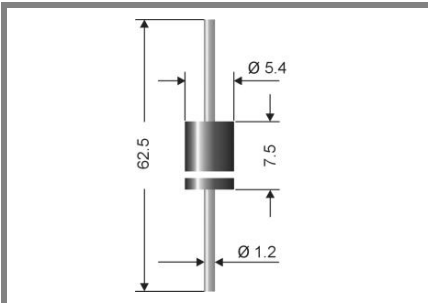

**Axial lead diode**

Type	Repetitive peak reverse voltage $V_{RRM}$ V	Surge peak reverse voltage $V_{RSM}$ V	Max. reverse recovery time $I_F = -A$ $I_R = -A$ $I_{RR} = -A$ $t_{rr}$ ns	Max. forward voltage $V_F^{(2)}$
SBH 1520S	20	20	-	0,48
SBH 1530S	30	30	-	0,48
SBH 1540S	40	40	-	0,48
SBH 1545S	45	45	-	0,48

## High temperature schottky barrier diodes

### SBH 1520S ... SBH 1545S

**Forward Current: 15 A**

**Reverse Voltage: 20 to 45 V**

### Features

- Max. solder temperature: 260°C
- Plastic material has UL classification 94V-0

### Mechanical Data

- Plastic case: 5,4 x 7,5 [mm]
- Weight approx.: 1,4 g
- Terminals: plated terminals solderable per MIL-STD-750
- Mounting position: any
- Standard packaging: 1250 pieces per ammo or per reel

- 1) Valid, if leads are kept at ambient temperature at a distance of 10 mm from case
- 2)  $V_F < 0,48V$  @  $I_F = 5 A$  and  $V_F < 0,56V$  @  $I_F = 15A$  ( $T_A = 25^\circ C$ )
- 3)  $T_A = 25^\circ C$
- 4) Thermal resistance from to lead/terminal at a distance 0 mm from case
- 5) Max. junction temperature  $T_j \leq 200^\circ C$  (reverse mode  $V_R \leq 50\%V_{RRM}$  and in forward mode)

Absolute Maximum Ratings		$T_A = 25^\circ C$ , unless otherwise specified	
Symbol	Conditions	Values	Units
$I_{FAV}$	Max. averaged fwd. current, R-load, $T_A = 50^\circ C$ <sup>1)</sup>	15	A
$I_{FRM}$	Repetitive peak forward current $f > 15 Hz$ <sup>1)</sup>	60	A
$I_{FSM}$	Peak forward surge current 50 Hz half sinus-wave <sup>3)</sup>	350	A
$i^2t$	Rating for fusing, $t < 10 ms$ <sup>3)</sup>	612	A <sup>2</sup> s
$R_{thA}$	Max. thermal resistance junction to ambient <sup>1)</sup>		K/W
$R_{thL}$	Max. thermal resistance junction to terminals <sup>4)</sup>	4	K/W
$T_j$	Operating junction temperature	- 50 ... + 185 ( $T_j \leq 200^\circ C$ <sup>5)</sup> )	°C
$T_s$	Storage temperature	- 50 ... + 175	°C

Characteristics		$T_A = 25^\circ C$ , unless otherwise specified	
Symbol	Conditions	Values	Units
$I_R$	Maximum leakage current, $T_j = 25^\circ C$ ; $V_R = V_{RRM}$	<50	µA
	$T_j = 100^\circ C$ ; $V_R = V_{RRM}$	<5	mA
$C_j$	Typical junction capacitance (at MHz and applied reverse voltage of V)	-	pF
$Q_{rr}$	Reverse recovery charge ( $U_R = V$ ; $I_F = A$ ; $dI_F/dt = A/ms$ )	-	µC
$E_{RSM}$	Non repetitive peak reverse avalanche energy ( $I_R = mA$ ; $T_j = ^\circ C$ ; inductive load switched off)	-	mJ

