

*Sensitive Gate
Silicon Controlled Rectifiers*

Features

- Repetitive Peak Off-State Voltage : 600V
- R.M.S On-State Current ($I_{T(RMS)}$)= 6 A)
- Low On-State Voltage (1.6V(Max.) @ I_{TM})

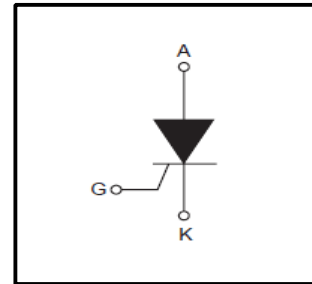

General Description

Sensitive gate triggering SCR is suitable for the application where requiring high bidirectional blocking voltage capability and also suitable for over voltage protection ,motor control circuit in power tool, inrush current limit circuit and heating control system.



Absolute Maximum Ratings ($T_J = 25^\circ\text{C}$ unless otherwise specified)

Symbol	Parameter	Condition	Ratings	Units
V_{DRM}	Repetitive Peak Off-State Voltage		600	V
$I_{T(AV)}$	Average On-State Current(180° Conduction Angle)	$T_c = 110^\circ\text{C}$	3.8	A
$I_{T(RMS)}$	R.M.S On-State Current(180° Conduction Angle)	$T_c = 110^\circ\text{C}$	6	A
I_{TSM}	Surge On-State Current	1/2 Cycle, 60Hz, Sine Wave Non-Repetitive	66	A
I^2t	I^2t for Fusing	$t = 10\text{ms}$	21	A^2s
di/dt	Critical rate of rise of on-state current	$F=60\text{Hz}, T_j=125^\circ\text{C}$	50	$\text{A}/\mu\text{s}$
P_{GM}	Forward Peak Gate Power Dissipation		5	W
$P_{G(AV)}$	Forward Average Gate Power Dissipation	$T_j=125^\circ\text{C}$	0.5	W
I_{FGM}	Forward Peak Gate Current		2	A
V_{RGM}	Reverse Peak Gate Voltage		5.0	V
T_J	Operating Junction Temperature		-40~125	$^\circ\text{C}$
T_{STG}	Storage Temperature		-40~150	$^\circ\text{C}$

Thermal Characteristics

Symbol	Parameter	Value	Units
$R_{\theta Jc}$	Thermal Resistance Junction to Case(DC)	3.12	$^\circ\text{C}/\text{W}$
$R_{\theta JA}$	Thermal Resistance Junction to Ambient(DC)	89	$^\circ\text{C}/\text{W}$

Electrical Characteristics ($T_C=25^\circ\text{C}$ unless otherwise noted)

Symbol	Parameter	Test Conditions	Value			Units
			Min	Typ	Max	
I _{DRM}	Repetitive Peak Off-State Current	V _{AK} =V _{DRM} T _C =25 °C	-	-	10	μA
		T _C =125 °C	-	-	200	μA
V _{TM}	Peak On-State Voltage (1)	I _{TM} =9A, t _p =380 μs	-	-	1.6	V
I _{GT}	Gate Trigger Current (2)	V _{AK} =6V(DC), R _L =10Ω T _C =125 °C	-	-	0.2	mA
V _{GT}	Gate Trigger Voltage (2)	V _D =6V(DC), R _L =10Ω T _C =125 °C	-	-	1.5	V
V _{GD}	Non-Trigger Gate Voltage (1)	V _{AK} =12V, R _L =100Ω T _C =125 °C	0.2			V
dv/dt	Critical Rate of Rise Off-State Voltage	Linear slope up to V _D =67%V _{DRM} , gate open T _J =125 °C	200	-	-	V/μs
I _H	Holding Current	I _T =100mA, Gate open T _C =25 °C	-	-	20	mA
I _L	Latching Current	I _G =1.2 I _{GT}	-	50	-	mA

***Notes:**

1. Pulse Width ≤1.0ms, Duty cycle ≤1%
2. R_{GK} Current not Included in measurement.

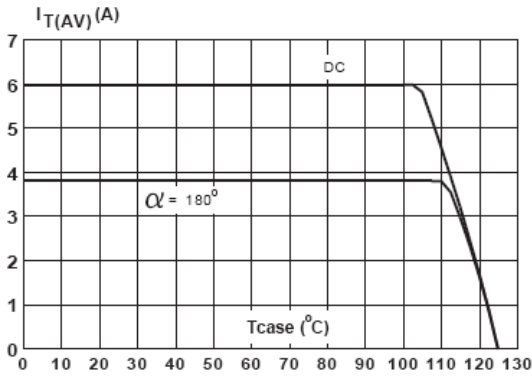

Fig.1 Average on -State current versus case temperature

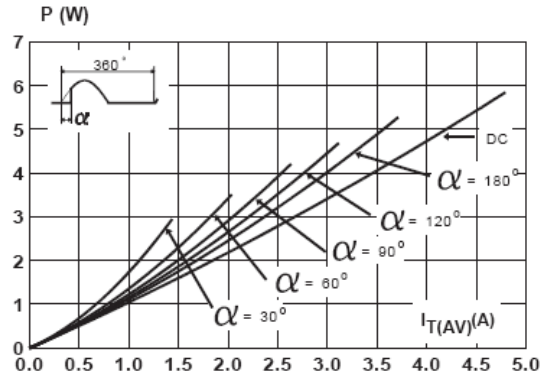

Fig.2 Correlation between maximum average power dissipation and maximum allowable temperatures (t_{amb} and t_{case}) for different thermal resistances heatsink+contact

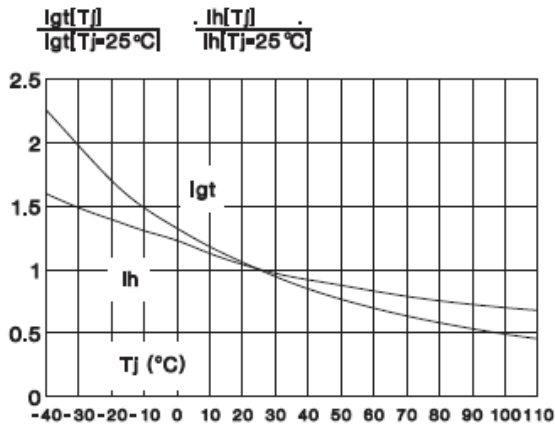

Fig.3 Relative variation of gate trigger current and holding current versus junction temperature

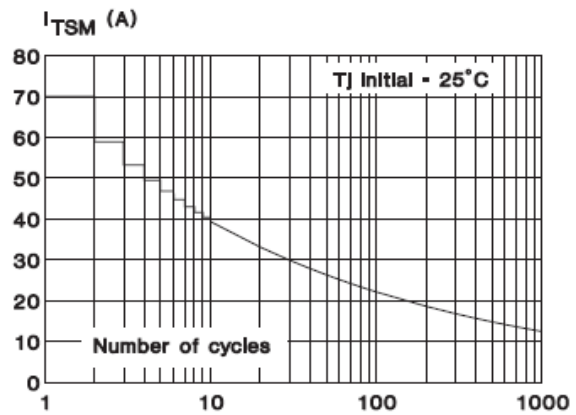

Fig.4 Maximum permissible non -repetitive peak On-state current I_{TSM} , versus number of cycles, for Sinusoidal currents. $f=60\text{Hz}$

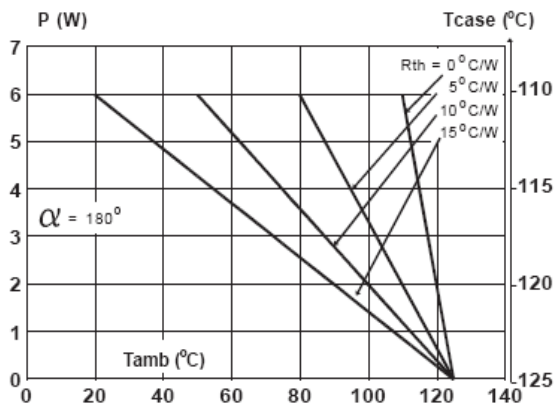

Fig.5 Correlation between Maximum average Power dissipation and Maximum allowable temperatures (t_{amb} and t_{case}) for different thermal resistances heatsink+contact.

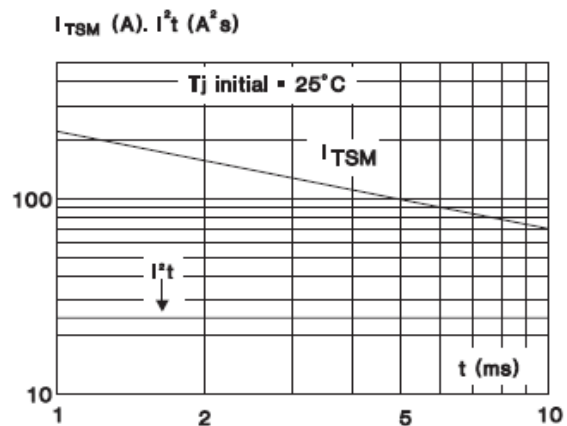

Fig.6 Non-repetitive surge peak on-state current for a sinusoidal pulse with width $T_p \leq 10\text{ms}$ and corresponding value of I^*t

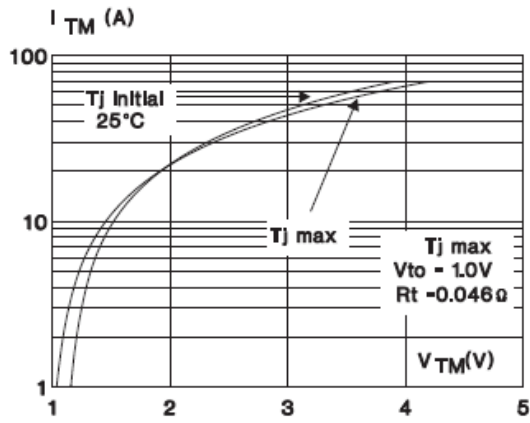

Fig.7 On-state characteristics(maximum values)

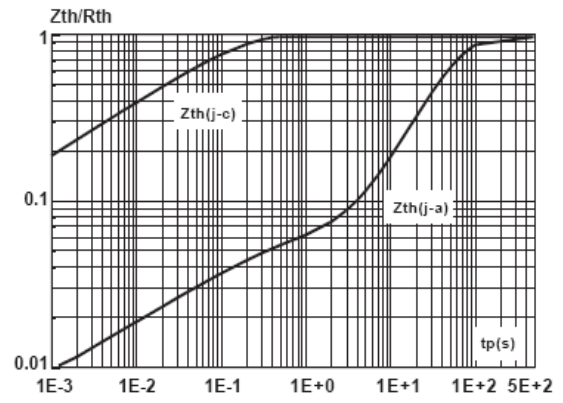

Fig.8 Transient thermal impedance $Z_{th\ j-mb}$, Versus Pulse width t_p

TO-252 Package Dimension

Unit: mm

