

S3C880A/F880A

8-BIT CMOS MICROCONTROLLERS USER'S MANUAL

Revision 3



ELECTRONICS

Important Notice

The information in this publication has been carefully checked and is believed to be entirely accurate at the time of publication. Samsung assumes no responsibility, however, for possible errors or omissions, or for any consequences resulting from the use of the information contained herein.

Samsung reserves the right to make changes in its products or product specifications with the intent to improve function or design at any time and without notice and is not required to update this documentation to reflect such changes.

This publication does not convey to a purchaser of semiconductor devices described herein any license under the patent rights of Samsung or others.

Samsung makes no warranty, representation, or guarantee regarding the suitability of its products for any particular purpose, nor does Samsung assume any liability arising out of the application or use of any product or circuit and specifically disclaims any and all liability, including without limitation any consequential or incidental damages.

"Typical" parameters can and do vary in different applications. All operating parameters, including "Typicals" must be validated for each customer application by the customer's technical experts.

Samsung products are not designed, intended, or authorized for use as components in systems intended for surgical implant into the body, for other applications intended to support or sustain life, or for any other application in which the failure of the Samsung product could create a situation where personal injury or death may occur.

Should the Buyer purchase or use a Samsung product for any such unintended or unauthorized application, the Buyer shall indemnify and hold Samsung and its officers, employees, subsidiaries, affiliates, and distributors harmless against all claims, costs, damages, expenses, and reasonable attorney fees arising out of, either directly or indirectly, any claim of personal injury or death that may be associated with such unintended or unauthorized use, even if such claim alleges that Samsung was negligent regarding the design or manufacture of said product.

S3C880A/F880A 8-Bit CMOS Microcontrollers
User's Manual, Revision 3
Publication Number: 23-S3-C880A/F880A-072004

© 2004 Samsung Electronics

All rights reserved. No part of this publication may be reproduced, stored in a retrieval system, or transmitted in any form or by any means, electric or mechanical, by photocopying, recording, or otherwise, without the prior written consent of Samsung Electronics.

Samsung Electronics' microcontroller business has been awarded full ISO-14001 certification (BSI Certificate No. FM24653). All semiconductor products are designed and manufactured in accordance with the highest quality standards and objectives.

Samsung Electronics Co., Ltd.
San #24 Nongseo-Ri, Kiheung-Eup
Yongin-City, Kyunggi-Do, Korea
C.P.O. Box #37, Suwon 449-900

TEL: (82)-(31)-209-1907
FAX: (82)-(31)-209-1889
Home-Page URL: [Http://www.intl.samsungsemi.com](http://www.intl.samsungsemi.com)

Printed in the Republic of Korea

Preface

The *S3C880A/F880A Microcontroller User's Manual* is designed for application designers and programmers who are using the S3C880A/F880A microcontroller for application development.

It is organized in two main parts:

Part I	Programming Model	Part II	Hardware Descriptions
--------	-------------------	---------	-----------------------

Part I contains software-related information to familiarize you with the microcontroller's architecture, programming model, instruction set, and interrupt structure. It has six chapters:

Chapter 1	Product Overview	Chapter 4	Control Registers
Chapter 2	Address Spaces	Chapter 5	Interrupt Structure
Chapter 3	Addressing Modes	Chapter 6	SAM8 Instruction Set

Chapter 1, "Product Overview," is a high-level introduction to S3C880A/F880A with general product descriptions, as well as detailed information about individual pin characteristics and pin circuit types.

Chapter 2, "Address Spaces," describes program and data memory spaces, the internal register file, and register addressing. Chapter 2 also describes working register addressing, as well as system stack and user-defined stack operations.

Chapter 3, "Addressing Modes," contains detailed descriptions of the addressing modes that are supported by the S3C8-series CPU.

Chapter 4, "Control Registers," contains overview tables for all mapped system and peripheral control register values, as well as detailed one-page descriptions in a standardized format. You can use these easy-to-read, alphabetically organized, register descriptions as a quick-reference source when writing programs.

Chapter 5, "Interrupt Structure," describes the S3C880A/F880A interrupt structure in detail and further prepares you for additional information presented in the individual hardware module descriptions in Part II.

Chapter 6, "SAM8 Instruction Set," describes the features and conventions of the instruction set used for all S3C8-series microcontrollers. Several summary tables are presented for orientation and reference. Detailed descriptions of each instruction are presented in a standard format. Each instruction description includes one or more practical examples of how to use the instruction when writing an application program.

A basic familiarity with the information in Part I will help you to understand the hardware module descriptions in Part II. If you are not yet familiar with the S3C8-series microcontroller family and are reading this manual for the first time, we recommend that you first read Chapters 1–3 carefully. Then, briefly look over the detailed information in Chapters 4, 5, and 6. Later, you can reference the information in Part I as necessary.

Part II "hardware Descriptions," has detailed information about specific hardware components of the S3C880A/F880A microcontroller. Also included in Part II are electrical, mechanical, MTP, and development tools data. It has 11 chapters:

Chapter 7	Clock Circuits	Chapter 13	On-Screen Display (OSD)
Chapter 8	nRESET and Power-Down	Chapter 14	Analog-to-Digital Converter
Chapter 9	I/O Ports	Chapter 15	Electrical Data
Chapter 10	Basic Timer and Timer 0	Chapter 16	Mechanical Data
Chapter 11	Timer A	Chapter 17	S3F880A MTP
Chapter 12	PWM and Capture	Chapter 18	Development Tools

Two order forms are included at the back of this manual to facilitate customer order for S3C880A/F880A microcontrollers: the Mask ROM Order Form, and the Mask Option Selection Form. You can photocopy these forms, fill them out, and then forward them to your local Samsung Sales Representative.

Table of Contents

Part I — Programming Model

Chapter 1 Product Overview

Overview	1-1
Features	1-2
Block Diagram	1-3
Pin Assignments	1-4
Pin Descriptions	1-5
Pin Circuits	1-7

Chapter 2 Address Spaces

Overview	2-1
Program Memory (ROM)	2-2
Register Architecture	2-3
ROM Code Option (RCOD_OPT)	2-5
Register Page Pointer (PP)	2-6
Effect of Different Instructions For Inter-Page Data Operations	2-7
Register Set 1	2-14
Register Set 2	2-14
Prime Register Space	2-14
Working Registers	2-16
Using The Register Pointers	2-17
Register Addressing	2-19
Common Working Register Area (C0H–CFH)	2-21
4-Bit Working Register Addressing	2-22
8-Bit Working Register Addressing	2-24
System and User Stacks	2-26

Chapter 3 Addressing Modes

Overview	3-1
Register Addressing Mode (R)	3-2
Indirect Register Addressing Mode (IR)	3-3
Indexed Addressing Mode (X)	3-7
Direct Address Mode (DA)	3-10
Indirect Address Mode (IA)	3-12
Relative Address Mode (RA)	3-13
Immediate Mode (IM)	3-14

Table of Contents (Continued)

Chapter 4 Control Registers

Overview	4-1
----------------	-----

Chapter 5 Interrupt Structure

Overview	5-1
Interrupt Types	5-1
S3C880A/F880A Interrupt Structure	5-2
Interrupt Vector Addresses	5-4
Enable/Disable Interrupt Instructions (EI, DI)	5-6
System-Level Interrupt Control Registers	5-6
Interrupt Processing Control Points	5-7
Peripheral Interrupt Control Registers	5-8
System Mode Register (SYM)	5-9
Interrupt Mask Register (IMR)	5-10
Interrupt Priority Register (IPR)	5-11
Interrupt Request Register (IRQ)	5-12
Interrupt Pending Function Types	5-13
Interrupt Source Polling Sequence	5-14
Interrupt Service Routines	5-14
Generating Interrupt Vector Addresses	5-15
Nesting of Vectored Interrupts	5-15
Instruction Pointer (IP)	5-15
Fast Interrupt Processing	5-16

Chapter 6 SAM8 Instruction Set

Overview	6-1
Data Types	6-1
Register Addressing	6-1
Addressing Modes	6-1
Flags Register (FLAGS)	6-6
Flag Descriptions	6-7
Instruction Set Notation	6-8
Condition Codes	6-12
Instruction Descriptions	6-13

Table of Contents (Continued)

Part II Hardware Descriptions

Chapter 7 Clock Circuit

Overview	7-1
System Clock Circuit.....	7-1
Clock Status During Power-Down Modes	7-2
System Clock Control Register (CLKCON).....	7-3
Relation Between L-C Oscillator and CPU Clock	7-5

Chapter 8 nRESET and Power-Down

System Reset	8-1
Overview	8-1
Hardware Reset Values.....	8-2
Power-Down Modes	8-5
Stop Mode.....	8-5
Idle Mode.....	8-6

Chapter 9 I/O Ports

Overview	9-1
Port Data Registers	9-2
Port 0.....	9-2
Port 1.....	9-4
Port 2.....	9-5
Port 3.....	9-6

Chapter 10 Basic Timer and Timer 0

Module Overview.....	10-1
Basic Timer Control Register (BTCON)	10-2
Basic Timer Function Description.....	10-3
Timer 0 Control Register (T0CON)	10-6
Timer 0 Function Description	10-7

Table of Contents (Continued)

Chapter 11 Timer A

Overview	11-1
Timer Clock Input	11-1
Timer A Interrupt Control	11-1
Timer A Function Description.....	11-2
Timer A Control Register (TACON).....	11-3

Chapter 12 PWM and Capture

PWM/Capture Module.....	12-1
PWM Control Register (PWMCN).....	12-2
PWM2–PWM5.....	12-3
PWM2–PWM5 Function Description	12-4
Staggered PWM Outputs	12-5
PWM0–PWM1	12-7
PWM Counter	12-7
PWM Data and Extension Registers	12-7
PWM Clock Rate	12-7
PWM0 and PWM1 Function Description.....	12-8
Capture Unit.....	12-12

Chapter 13 On-Screen Display (OSD)

Overview	13-1
Pattern Generation Software.....	13-1
Internal OSD Clock.....	13-2
OSD Video RAM	13-2
OSD Control Register Overview.....	13-5
Display Control Register (DSPCON).....	13-6
Character Size Control Register (CHACON)	13-8
Fade-In and Fade-Out Control Register (FADECON)	13-10
Display Position Control.....	13-14
Row Control Register (ROWCON)	13-15
Column Control Register (CLMCON).....	13-15
Character Color Control Register (COLBUF).....	13-17
Background Color Control.....	13-18
V-SYNC Blank Control Register (VSBCON)	13-20
V-SYNC Blank and Top Margin Timing Diagram	13-21
Half-tone Signal Control Register (HTCON).....	13-22
OSD Field Control Register (OSDFLD)	13-25
OSD Palette Color Control.....	13-27
OSD Space Color Control Register (OSDCOL)	13-31
OSD Border/Fringe Function.....	13-33
OSD Smooth Function.....	13-35

Table of Contents (Concluded)

Chapter 14 Analog-to-Digital Converter

Overview	14-1
Using A/D Pins for Standard Digital Input	14-2
A/D Converter Control Register (ADCON)	14-2
Internal Reference Voltage Levels	14-3
Conversion Timing	14-4
Internal A/D Conversion Procedure	14-4

Chapter 15 Electrical Data

Overview	15-1
----------------	------

Chapter 16 Mechanical Data

Overview	16-1
----------------	------

Chapter 17 S3F880A

Overview	17-1
----------------	------

Chapter 18 Development Tools

Overview	18-1
Shine	18-1
SAMA Assembler	18-1
SASM88	18-1
HEX2ROM	18-1
Target Boards	18-2
TB880A Target Board	18-3

List of Figures

Figure Number	Title	Page Number
1-1	Block Diagram	1-3
1-2	S3C880A/F880A Pin Assignment (42-SDIP)	1-4
1-3	S3C880A/F880A Pin Assignment (44-QFP)	1-5
1-4	Pin Circuit Type 1 (V-Sync H-Sync, CAPA)	1-8
1-5	Pin Circuit Type 2 (P2.0–P2.7, P0.0–P0.3, PWM0–PWM5, T0, OSDHT)	1-8
1-6	Pin Circuit Type 3 (P0.4–P0.5, P1.6–P1.7, T0CK)	1-8
1-7	Pin Circuit Type 4 (Vblue, Vgreen, Vred, Vblank).....	1-9
1-8	Pin Circuit Type 5 (P1.4–P1.5).....	1-9
1-9	Pin Circuit Type 6 (P3.0–P3.1, P0.6–P0.7, ADC0–ADC3).....	1-9
1-10	Pin Circuit Type 7 (P1.0–P1.3, INT0–INT3).....	1-10
1-11	Pin Circuit Type 8 (nRESET)	1-10
2-1	Program Memory Address Spaces.....	2-2
2-2	Internal Register File Organization.....	2-4
2-3	ROM Code Option (RCOD_OPT).....	2-5
2-4	Register Page Pointer (PP)	2-6
2-5	Programming Tip Example for Inter-Page Data Operations.....	2-7
2-6	Set 1, Set 2, and Prime Area Register Map	2-15
2-7	8-Byte Working Register Areas (Slices).....	2-16
2-8	Contiguous 16-Byte Working Register Block.....	2-17
2-9	Non-Contiguous 16-Byte Working Register Block.....	2-18
2-9	16-Bit Register Pairs.....	2-19
2-10	Register File Addressing	2-20
2-12	Common Working Register Area	2-21
2-13	4-Bit Working Register Addressing.....	2-23
2-14	4-Bit Working Register Addressing Example.....	2-23
2-15	8-Bit Working Register Addressing.....	2-24
2-16	8-Bit Working Register Addressing Example.....	2-25
2-17	Stack Operations	2-26
3-1	Register Addressing	3-2
3-2	Working Register Addressing	3-2
3-3	Indirect Register Addressing to Register File.....	3-3
3-4	Indirect Register Addressing to Program Memory	3-4
3-5	Indirect Working Register Addressing to Register File.....	3-5
3-6	Indirect Working Register Addressing to Program or Data Memory.....	3-6
3-7	Indexed Addressing to Register File	3-7
3-8	Indexed Addressing to Program or Data Memory with Short Offset.....	3-8
3-9	Indexed Addressing to Program or Data Memory	3-9
3-10	Direct Addressing for Load Instructions.....	3-10
3-11	Direct Addressing for Call and Jump Instructions	3-11
3-12	Indirect Addressing.....	3-12
3-13	Relative Addressing	3-13
3-14	Immediate Addressing	3-14
4-1	Register Description Format	4-5

List of Figures (Continued)

Figure Number	Title	Page Number
5-1	S3C8-Series Interrupt Types	5-2
5-2	S3C880A/F880A Interrupt Structure	5-3
5-3	ROM Vector Address Area	5-4
5-4	Interrupt Function Diagram	5-7
5-5	System Mode Register (SYM)	5-9
5-6	Interrupt Mask Register (IMR)	5-10
5-7	Interrupt Priority Register (IPR)	5-11
5-8	Interrupt Request Register (IRQ)	5-12
6-1	System Flags Register (FLAGS).....	6-6
7-1	Main Oscillator Circuit (External Crystal or Ceramic Resonator).....	7-1
7-2	System Clock Circuit Diagram.....	7-2
7-3	System Clock Control Register (CLKCON).....	7-3
7-4	L-C Oscillator Circuit for OSD.....	7-4
8-1	Stop State Timing Diagram.....	8-7
9-1	Port Data Register Format.....	9-2
9-2	Port 0 High-Byte Control Register (P0CONH)	9-3
9-3	Port 0 Low-Byte Control Register (P0CONL)	9-3
9-4	Port 1 High-Byte Control Register (P1CONH)	9-4
9-5	Port 1 Low-Byte Control Register (P1CONL)	9-4
9-6	Port 2 High-Byte Control Register (P2CONH)	9-5
9-7	Port 2 Low-Byte Control Register (P2CONL)	9-5
9-8	Port 3 Control Register (P3CON).....	9-6
10-1	Basic Timer Control Register (BTCON)	10-2
10-2	Oscillation Stabilization Time on RESET	10-4
10-3	Oscillation Stabilization Time on STOP Mode Release.....	10-5
10-4	Timer 0 Control Register (T0CON)	10-6
10-5	Timer 0 Function Diagram (Interval Timer Mode)	10-7
10-6	Timer 0 Function Diagram (PWM Mode)	10-8
10-7	Basic Timer and Timer 0 Block Diagram	10-9
11-1	Timer A Block Diagram	11-2
11-2	Timer A Control Register (TACON)	11-3

List of Figures (Continued)

Figure Number	Title	Page Number
12-1	PWM Control Register (PWMCON).....	12-2
12-2	Block Diagram for PWM2–PWM5	12-3
12-3	PWM Waveforms for PWM2–PWM5	12-5
12-4	PWM Clock to PWM2–PWM5 Output Delays.....	12-6
12-5	Block Diagram for PWM0 and PWM1.....	12-9
12-6	Decision Flowchart for PWM0 Programming Tip	12-10
12-7	Block Diagram for Capture A	12-12
12-8	Decision Flowchart (Main Routine and Timer A Interrupt).....	12-14
12-9	Decision Flowchart for Capture A Interrupt	12-15
13-1	On-Screen Display Function Block Diagram.....	13-3
13-2	On-Screen Display Video RAM Data Organization.....	13-4
13-3	OSD Display Control Register (DSPCON).....	13-6
13-4	OSD Character Size Control Register (CHACON)	13-8
13-5	OSD Character Sizing Dimensions.....	13-9
13-6	OSD Fade Control Register (FADECON)	13-10
13-7	Line and Row Addressing Conventions when ROWCON.2-0 = "100".....	13-11
13-8	OSD Fade Function Example: Fade After	13-12
13-9	OSD Fade Function Example: Fade Before.....	13-13
13-10	252-Byte On-Screen Character Display Map (Decimal)	13-14
13-11	252-Byte On-Screen Character Display Map (Hexadecimal)	13-14
13-12	OSD Row Control Register (ROWCON)	13-15
13-13	OSD Column Control Register (CLMCON).....	13-15
13-14	OSD Display Formatting and Spacing Conventions	13-16
13-15	OSD Character Color Buffer Register (COLBUF).....	13-17
13-16	Background Color Display Conventions.....	13-18
13-17	OSD Background Color Control Register (COLCON)	13-19
13-18	V-sync Blank Control Register (VSBCON)	13-20
13-19	V-sync Blank and Top Margin Timing Diagram	13-21
13-20	Halftone Signal Control Register (HTCON).....	13-23
13-21	Halftone or Character Background Signal Output	13-24
13-22	OSD Field Control Register (OSDFLD)	13-25
13-23	Field Detect in Before V-sync	13-26
13-24	Field Detect in After V-sync.....	13-26
13-25	OSD Palette Color Mode Register R1 (OSDPLTR1)	13-27
13-26	OSD Palette Color Mode Register R2 (OSDPLTR2)	13-28
13-27	OSD Palette Color Mode Register G1 (OSDPLTG1).....	13-29
13-28	OSD Palette Color Mode Register G2 (OSDPLTG2).....	13-29
13-29	OSD Palette Color Mode Register B1 (OSDPLTB1)	13-30
13-30	OSD Palette Color Mode Register B2 (OSDPLTB2)	13-30
13-31	OSD Space Color Control Register (OSDCOL)	13-32
13-32	OSD Fringe/Border Control Register 1 (OSDFRG1).....	13-34
13-33	OSD Fringe/Border Control Register 2 (OSDFRG2).....	13-34

List of Figures (Concluded)

Figure Number	Title	Page Number
13-34	OSD Smooth Control Register 1 (OSDSMH1)	13-35
13-35	OSD Smooth Control Register 2 (OSDSMH2)	13-36
13-36	Smoothing/Fringing/Priority of Smoothing and Fringing.....	13-36
13-37	Decision Flowchart for Row Interrupt Function Programming Tip.....	13-37
13-38	Decision Flowchart for Fade Function Programming Tip	13-40
14-1	A/D Converter Control Register (ADCON).....	14-2
14-2	A/D Converter Circuit Diagram	14-3
14-3	A/D Converter Data Register (ADDATAH/L).....	14-3
14-4	S3C880A/F880A A/D Converter Timing Diagram.....	14-4
14-5	Recommended A/D Converter Circuit for Highest Absolute Accuracy.....	14-5
15-1	Input Timing Measurement Points for t_{NF1} and t_{NF2}	15-5
15-2	Stop Mode Release Timing When Initiated by a nRESET	15-5
15-3	Clock Timing Measurement Points for X_{IN}	15-6
16-1	42-Pin SDIP Package Dimensions (42-SDIP-600).....	16-1
16-2	44-Pin QFP Package Dimensions (44-QFP-1010B)	16-2
17-1	Descriptions of Pins Used to Read/Write the Flash ROM (S3F880A).....	17-2
18-1	SMDS Product Configuration (SMDS2+).....	18-2
18-2	TB880A Target Board Configuration.....	18-3
18-3	50-Pin DIP Connector J101 for TB880A.....	18-7
18-4	S3C880A/F880A Probe Adapter for 42-SDIP Package	18-7

List of Tables

Table Number	Title	Page Number
1-1	S3C880A/F880A Pin Descriptions.....	1-5
2-1	Program ROM and Character ROM Area by the Font Figure.....	2-3
2-2	Register Type Summary.....	2-3
4-1	Set 1 Registers	4-2
4-2	Set 1, Bank 0 Registers	4-2
4-3	Set 1, Bank 1 Registers	4-4
5-1	S3C880A/F880A Interrupt Vectors	5-5
5-2	Interrupt Control Register Overview	5-6
5-3	Interrupt Source Control Registers.....	5-8
6-1	Instruction Group Summary	6-2
6-2	Flag Notation Conventions	6-8
6-3	Instruction Set Symbols.....	6-8
6-4	Instruction Notation Conventions	6-9
6-5	Opcode Quick Reference	6-10
6-6	Condition Codes	6-12
8-1	Set 1 Register Values after a Reset	8-2
8-2	Set 1, Bank 0 Register Values after a Reset	8-3
8-3	Page 1 Video RAM Register Values after a Reset	8-4
9-1	S3C880A/F880A Port Configuration Overview	9-1
9-2	Port Data Register Summary	9-2
12-1	PWM0 and PWM1 Control and Data Registers	12-8
12-2	PWM Output "Stretch" Values for Extension Registers PWM0EX and PWM1EX.....	12-8
13-1	OSD Function Block Summary	13-1
15-1	Absolute Maximum Ratings.....	15-2
15-2	D.C. Electrical Characteristics.....	15-2
15-3	Input/Output Capacitance.....	15-4
15-4	A.C. Electrical Characteristics.....	15-4
15-5	Analog R,G,B Output	15-4
15-6	Data Retention Supply Voltage in Stop Mode.....	15-5
15-7	Main Oscillator and L-C Oscillator Frequency.....	15-6
15-8	Main Oscillator Clock Stabilization Time.....	15-7
15-9	A/D Converter Electrical Characteristics	15-7
17-1	Power Selection Settings for TB880A	17-4
17-2	The SMDS2 + Tool Selection Setting	17-5
17-3	OSD Font ROM Selection Setting.....	17-5
17-4	Using Single Header Pins as the Input Path for External Trigger Sources.....	17-6

List of Programming Tips

Description	Page Number
Chapter 2: Address Spaces	
Data Operations Between Register Pages	2-7
Examples of Inter-Page Data Transfer Operations	2-8
Setting the Register Pointers	2-17
Using the RPs to Calculate the Sum of a Series of Registers	2-18
Addressing the Common Working Register Area	2-22
Chapter 5: Interrupt Structure	
Programming Level IRQ0 as a Fast Interrupt	5-18
Chapter 12: PWM and Capture	
Programming PWM0 to Sample Specifications	12-10
Programming the Capture Module to Sample Specifications	12-16
Chapter 13: On-Screen Display (OSD)	
Row Interrupt Function	13-37
Writing Character Code and Color Data to the OSD Video RAM.....	13-39
OSD Fade Function; Line and Row Counters	13-39
Manipulating OSD Character Colors; Halftone Function.....	13-43
OSD Character Size, Background Color, and Display Position.....	13-45
Helpful Hints About COLBUF and OSD Character Code 0	13-45
Chapter 14: Analog-to-Digital Converter	
Configuring A/D Converter.....	14-5

List of Register Descriptions

Register Identifier	Full Register Name	Page Number
ADCON	A/D Converter Control Register	4-6
BTCN	Basic Timer Control Register	4-7
CHACON	OSD Character Size Control Register	4-8
CLKCON	System Clock Control Register	4-9
CLMCON	OSD Column Control Register	4-10
COLBUF	OSD Character Color Buffer	4-11
COLCON	OSD Background Color Control Register	4-12
DSPCON	On-Screen Display Control Register	4-13
EMT	External Memory Timing Register	4-14
FADECON	OSD Fade Control Register	4-15
FLAGS	System Flag Register	4-16
HCON	HDLC Control Register	4-17
IMR	Interrupt Mask Register	4-18
IPH	Instruction Pointer (High Byte)	4-19
IPL	Instruction Pointer (Low Byte)	4-19
IPR	Interrupt Priority Register	4-20
IRQ	Interrupt Request Register	4-21
OSDCOL	OSD Space Color Control Register	4-22
OSDFLD	OSD Field Control Register	4-23
OSDFRG1	OSD Fringe/Border Control Register 1	4-24
OSDFRG2	OSD Fringe/Border Control Register 2	4-25
OSDPLTB1	OSD Palette Color Mode Register B1	4-26
OSDPLTB2	OSD Palette Color Mode Register B2	4-27
OSDPLTG1	OSD Palette Color Mode Register G1	4-28
OSDPLTG2	OSD Palette Color Mode Register G2	4-29
OSDPLTR1	OSD Palette Color Mode Register R1	4-30
OSDPLTR2	OSD Palette Color Mode Register R2	4-31

List of Register Descriptions (Continued)

Register Identifier	Full Register Name	Page Number
OSDSMH1	OSD Smooth Control Register 1	4-32
OSDSMH2	OSD Smooth Control Register 2	4-33
P0CONH	Port 0 Control Register (High Byte)	4-34
P0CONL	Port 0 Control Register (Low Byte)	4-35
P1CONH	Port 1 Control Register (High Byte)	4-36
P1CONL	Port 1 Control Register (Low Byte)	4-37
P2CONH	Port 2 Control Register (High Byte)	4-38
P2CONL	Port 2 Control Register (Low Byte)	4-39
P3CONH	Port 3 Control Register (High Byte)	4-40
PP	Register Page Pointer	4-41
PWMCON	PWM Control Register	4-42
ROWCON	OSD Row Position Control Register	4-43
RP0	Register Pointer 0	4-44
RP1	Register Pointer 1	4-44
SPH	Stack Pointer (High Byte)	4-45
SPL	Stack Pointer (Low Byte)	4-45
STCON	Stop Control Register	4-46
SYM	System Mode Register	4-47
TACON	8-Bit Timer A Control Register	4-48
T0CON	Timer 0 Control Register	4-49
VSBCON	V-Sync Blank Control Register	4-50

List of Instruction Descriptions

Instruction Mnemonic	Full Register Name	Page Number
ADC	Add with Carry	6-14
ADD	Add.....	6-15
AND	Logical AND.....	6-16
BAND	Bit AND.....	6-17
BCP	Bit Compare.....	6-18
BITC	Bit Complement	6-19
BITR	Bit Reset	6-20
BITS	Bit Set.....	6-21
BOR	Bit OR.....	6-22
BTJRF	Bit Test, Jump Relative on False.....	6-23
BTJRT	Bit Test, Jump Relative on True.....	6-24
BXOR	Bit XOR	6-25
CALL	Call Procedure	6-26
CCF	Complement Carry Flag	6-27
CLR	Clear	6-28
COM	Complement	6-29
CP	Compare.....	6-30
CPIJE	Compare, Increment, and Jump on Equal.....	6-31
CPIJNE	Compare, Increment, and Jump on Non-Equal.....	6-32
DA	Decimal Adjust.....	6-33
DEC	Decrement.....	6-35
DECW	Decrement Word	6-36
DI	Disable Interrupts	6-37
DIV	Divide (Unsigned).....	6-38
DJNZ	Decrement and Jump if Non-Zero	6-39
EI	Enable Interrupts	6-40
ENTER	Enter.....	6-41
EXIT	Exit.....	6-42
IDLE	Idle Operation.....	6-43
INC	Increment	6-44
INCW	Increment Word.....	6-45
IRET	Interrupt Return	6-46
JP	Jump.....	6-47
JR	Jump Relative.....	6-48
LD	Load.....	6-49
LDB	Load Bit.....	6-51

List of Instruction Descriptions (Continued)

Instruction Mnemonic	Full Register Name	Page Number
LDC/LDE	Load Memory	6-52
LDCD/LDED	Load Memory and Decrement	6-54
LDCI/LDEI	Load Memory and Increment	6-55
LDCPD/LDEPD	Load Memory with Pre-Decrement	6-56
LDCPI/LDEPI	Load Memory with Pre-Increment	6-57
LDW	Load Word	6-58
MULT	Multiply (Unsigned)	6-59
NEXT	Next	6-60
NOP	No Operation	6-61
OR	Logical OR	6-62
POP	Pop from Stack	6-63
POPUD	Pop User Stack (Decrementing)	6-64
POPUI	Pop User Stack (Incrementing)	6-65
PUSH	Push to Stack	6-66
PUSHUD	Push User Stack (Decrementing)	6-67
PUSHUI	Push User Stack (Incrementing)	6-68
RCF	Reset Carry Flag	6-69
RET	Return	6-70
RL	Rotate Left	6-71
RLC	Rotate Left through Carry	6-72
RR	Rotate Right	6-73
RRC	Rotate Right through Carry	6-74
SB0	Select Bank 0	6-75
SB1	Select Bank 1	6-76
SBC	Subtract with Carry	6-77
SCF	Set Carry Flag	6-78
SRA	Shift Right Arithmetic	6-79
SRP/SRP0/SRP1	Set Register Pointer	6-80
STOP	Stop Operation	6-81
SUB	Subtract	6-82
SWAP	Swap Nibbles	6-83
TCM	Test Complement under Mask	6-84
TM	Test under Mask	6-85
WFI	Wait for Interrupt	6-86
XOR	Logical Exclusive OR	6-87

1

PRODUCT OVERVIEW

OVERVIEW

The S3C880A/F880A microcontroller has 48-Kbytes of on-chip program memory. This chips have a 336-byte general-purpose internal register file. The interrupt structure has 9 interrupt sources with 9 interrupt vectors. The CPU recognizes seven interrupt priority levels.

Using a modular design approach, the following peripherals were integrated with the SAM88LP core to make the S3C880A/F880A microcontrollers suitable for use in color television and other types of screen display applications:

- Four programmable I/O ports (26 pins total: 16 general-purpose I/O pins; 10 n-channel, open-drain output pins)
- Four Channel A/D converter (8-bit resolution)
- Two 14-bit PWM output and four 8-bit PWM output.
- Basic timer (BT) with watchdog timer function
- One 8-bit general-purpose timer/counter (T0) with interval timer Mode and PWM Output Mode
- One 8-bit timer/counters (TA) with prescalers and interval timer mode
- On-screen display (OSD) with a wide range of programmable features, including halftone control signal output

The S3C880A/F880A is available in a versatile 42-pin SDIP, 44-pin QFP package.

FEATURES

CPU

- SAM88LP CPU core

Memory

- 48-Kbyte internal program and OSD font memory
- 336-byte general-purpose register area

Instruction Set

- 78 instructions
- IDLE and STOP instructions added for power-down modes

Instruction Execution Time

- 750 ns (minimum) with an 8-MHz CPU clock

Interrupts

- 9 interrupt sources with 9 vectors
- 7 interrupt levels
- Fast interrupt processing for select levels

General I/O

- Four I/O ports (26 pins total)
- Six open-drain pins for up to 6-volt loads
- Four open-drain pins for up to 5-volt loads

8-Bit Basic Timer

- Three select able internal clock frequencies
- Watchdog or oscillation stabilization function

Timer/Counters

- One 8-bit timer/counter (T0) with three internal clocks or an external clock, and two operating modes; Interval mode or PWM mode
- One general-purpose 8-bit timer/counters with interval timer (timer A)

A/D Converter

- Four analog input pins
- 8-bit resolution
- 25 us conversion time (8-MHz CPU clock)

Pulse Width Modulation Module

- 14-bit PWM with 2-channel output
- 8-bit PWM with 4-channel output
- PWM counter and data capture input pin
- Frequency: 5.859 kHz to 23.437 kHz with a 6-MHz CPU clock

On-Screen Display (OSD)

- Video RAM: 252 × 14 bits
- Character generator ROM: Variable size
Max: 1024 × 18 × 16 bits
Min: Default 2 font reserved.
(1024 display characters: fixed: 2, variable: 1022)
- 252 display positions (12 rows × 21 columns)
- 16-dot × 18-dot character resolution
- 16 different character sizes
- 64 character colors
- Fade In/Out
- 64 colors for character and frame background
- Halftone control signal output; select able for individual characters
- Synchronous polarity selector for H-sync and V-sync input
- Bordering function
- Smoothing function
- Fringing function

Oscillator Frequency

- 5-MHz to 8-MHz external crystal oscillator (when OSD block active)
- Maximum 8-MHz CPU clock

Operating Temperature Range

- -20°C to +85°C

Operating Voltage Range

- 4.5 V to 5.5 V

Package Type

- 42-pin SDIP, 44-pin QFP

BLOCK DIAGRAM

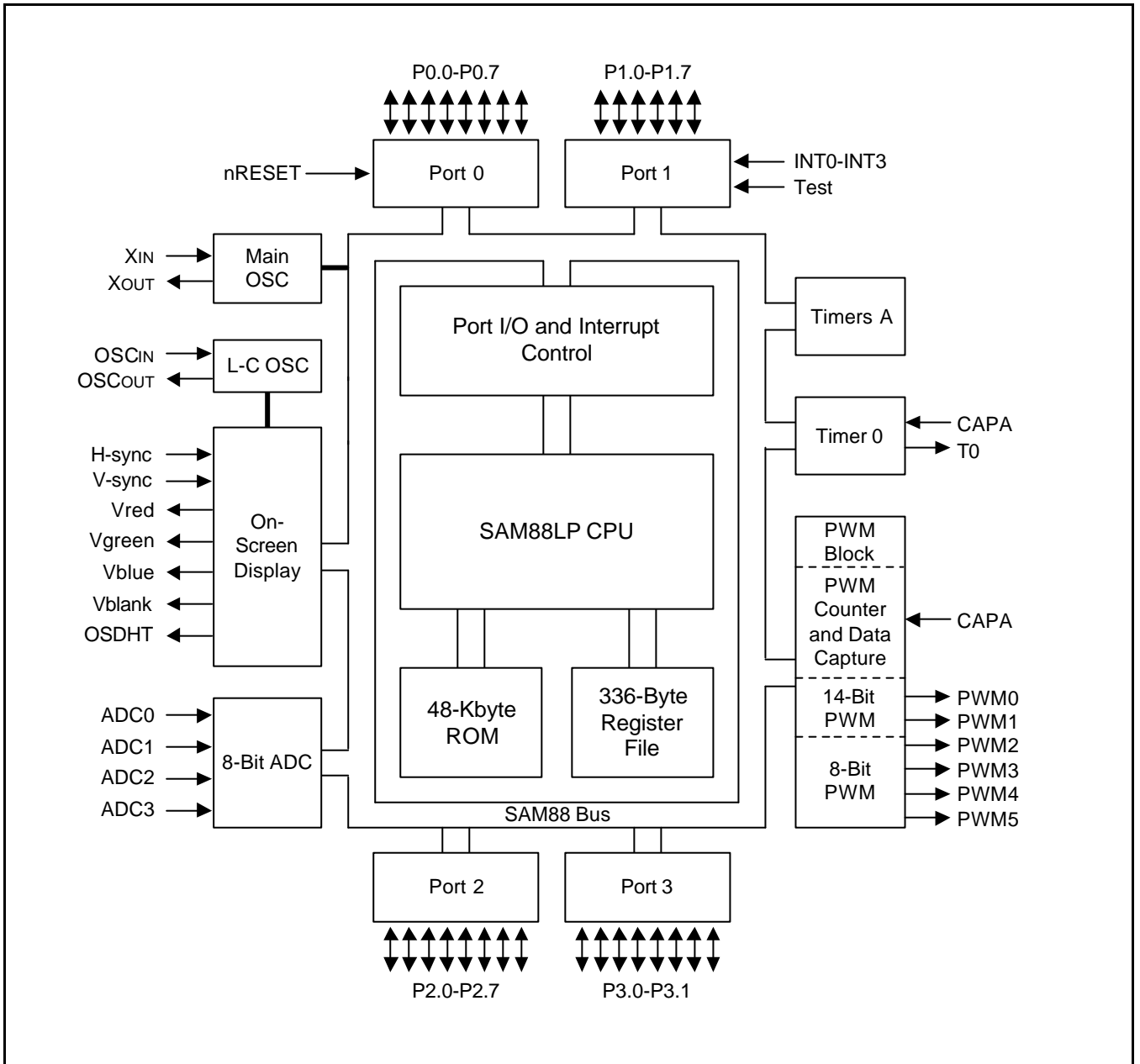


Figure 1-1. Block Diagram

PIN ASSIGNMENTS

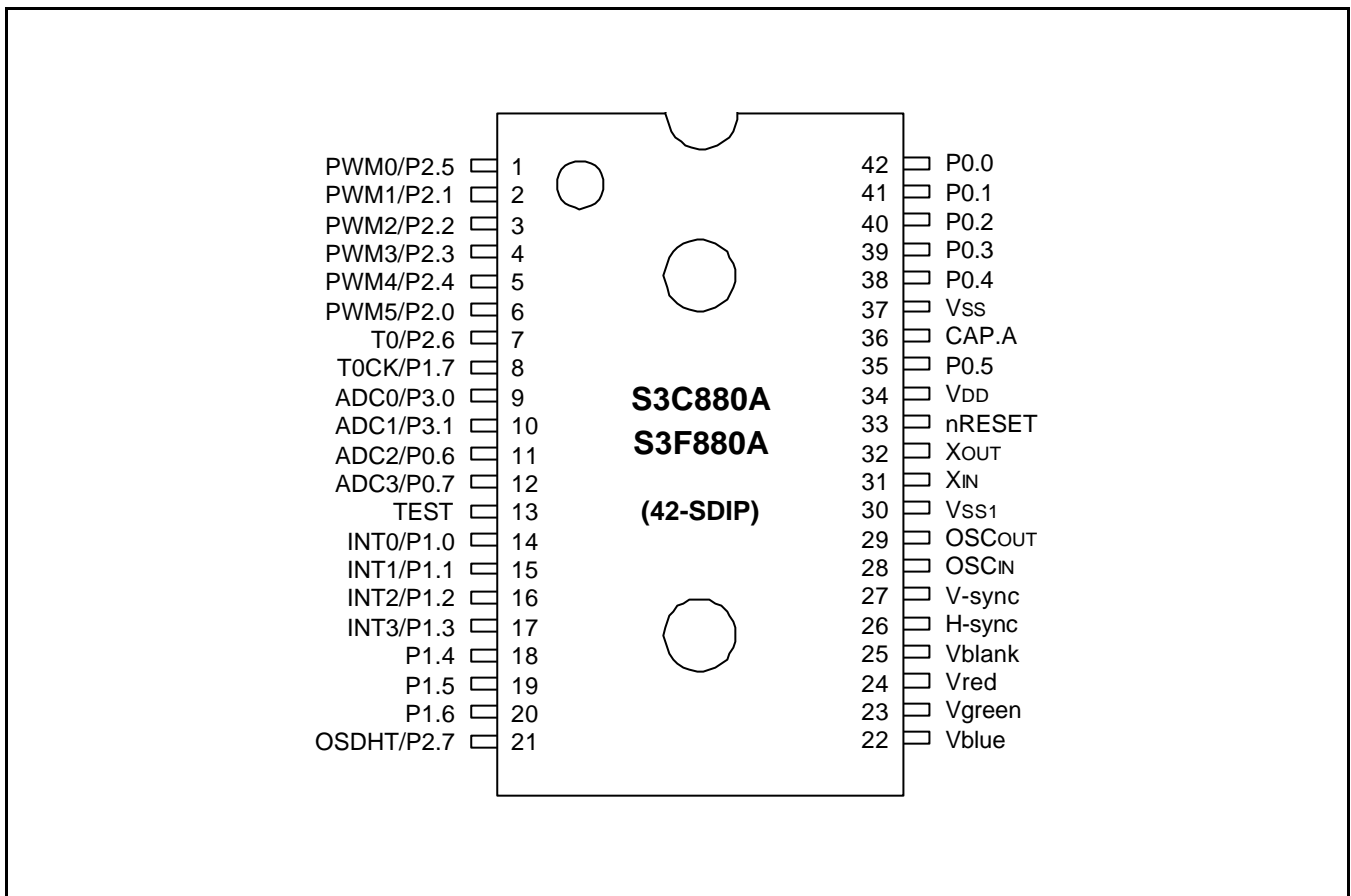


Figure 1-2. S3C880A/F880A Pin Assignment (42-SDIP)

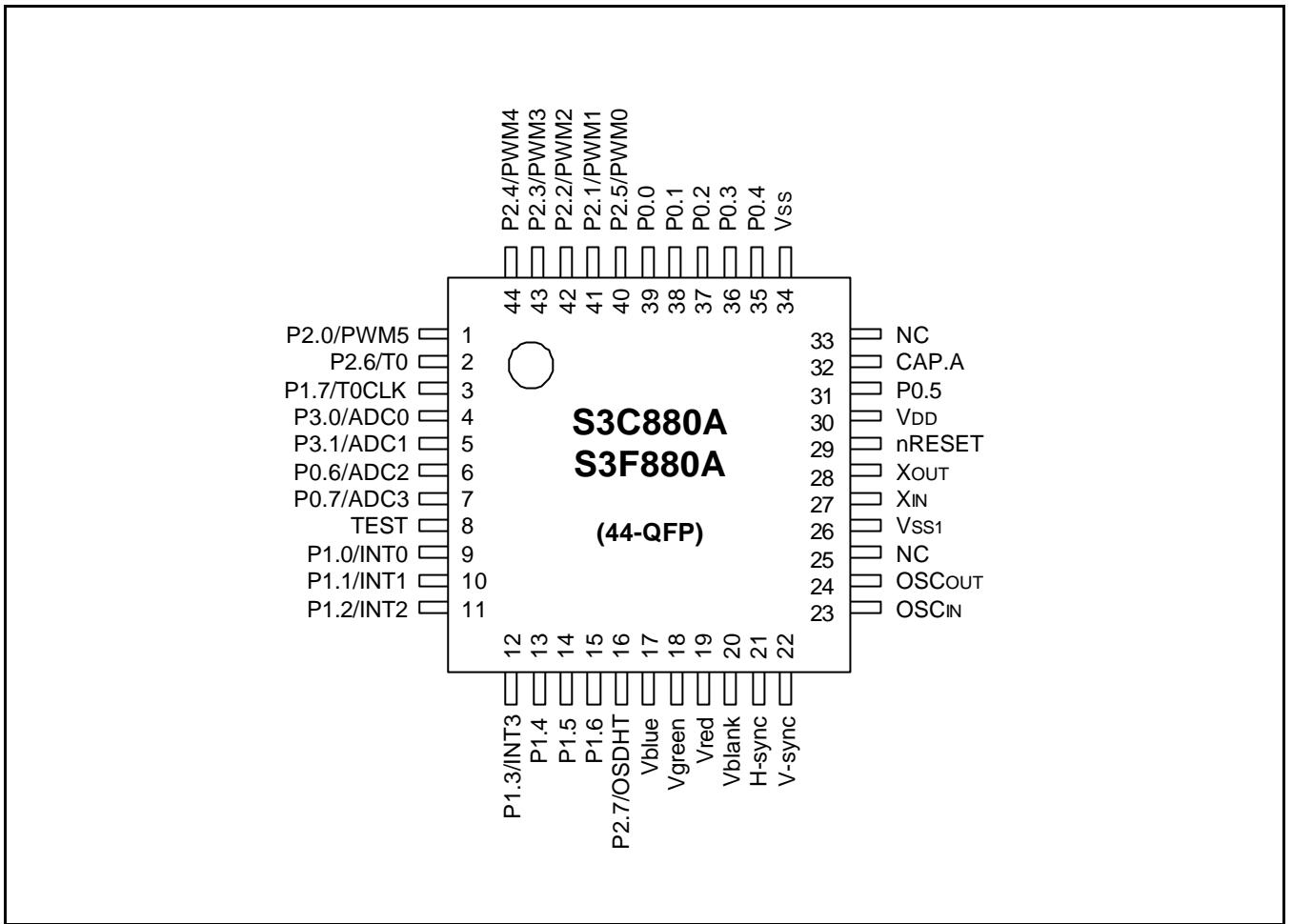


Figure 1-3. S3C880A/F880A Pin Assignment (44-QFP)

PIN DESCRIPTIONS

Table 1-1. S3C880A/F880A Pin Descriptions

Pin Name	Pin Type	Pin Description	Circuit Type	Pin Numbers	Share Pins
P0.0–P0.3	I/O	General I/O port (4-bit), configurable for digital input or n-channel open-drain, push-pull output. Pins can withstand up to 5-volt loads.	2	39–42 (39–36)	(See pin description)
P0.4–P0.5		General I/O port (2-bit), configurable for digital input or push-pull output.	3	38, 35 (35, 31)	
P0.6–P0.7		General I/O port (2-bit), configurable for digital input or n-channel open-drain output. P0.6-P0.7 can withstand up to 5-volt loads. Multiplexed for alternative use as external inputs ADC2-ADC3.	6	11–12 (6–7)	ADC2–ADC3
P1.0–P1.3	I/O	General I/O port (4-bit), configurable for digital input or n-channel open-drain output. P1.0-P1.3 can withstand up to 6-volt loads. Multiplexed for alternative use as external interrupt inputs INT0-INT3	7	14–17 (9–11)	INT0–INT3
P1.4–P1.5		General I/O port (2-bit). configurable for digital input or n-channel open-drain output. P1.4-P1.5 can withstand up to 6-volt loads. High current port (10mA).	5	18–19 (13–14)	
P1.6–P1.7		General I/O port (2-bit). configurable for digital input or push-pull output. Each pin has an alternative function. P1.7: T0CK (Timer 0 Clock Input)	3	20, 8 (15, 3)	T0CK
P2.0–P2.7	I/O	General I/O port (8-bit). Input/output mode or n-channel open-drain, push-pull output mode is software configurable. Pins can withstand up to 5-volt loads. Each pin has an alternative function. P2.0: PWM5 (8-bit PWM output) P2.1: PWM1 (14-bit PWM output) P2.2: PWM2 (8-bit PWM output) P2.3: PWM3 (8-bit PWM output) P2.4: PWM4 (8-bit PWM output) P2.5: PWM0 (14-bit PWM output) P2.6: T0 (Timer 0 PWM and Interval output) P2.7: OSDHT (Half-tone signal output)	2	1–7, 21 (1, 41–44, 40, 2, 16)	PWM0–PWM5 T0, OSDHT
P3.0–P3.1	I/O	General I/O port (2-bit), configurable for digital input or n-channel open-drain output. P3.0-P3.1 can withstand up to 5-volt loads. Multiplexed for alternative use as external inputs ADC0-ADC1.	6	9–10 (4–5)	ADC0–ADC1

NOTE: Parentheses indicate pin number for 44-QFP package.

Table 1-1. S3C880A/F880A Pin Descriptions (Continued)

Pin Name	Pin Type	Pin Description	Circuit Type	Pin Numbers	Share Pins
PWM0	O	Output pin for 14-bit PWM circuit	1	1 (40)	P2.5
PWM1	O	Output pin for 14-bit PWM circuit	2	2 (41)	P2.1
PWM2–PWM4	O	Output pin for 8-bit PWM circuit	2	3–5 (42–44)	P2.2–P2.4
PWM5	O	Output pin for 8-bit PWM circuit	2	6 (1)	P2.0
ADC0–ADC1	I	Analog inputs for 8-bit A/D converter	6	9,10 (4,5)	P3.0–P3.1
ADC2–ADC3	I	Analog inputs for 8-bit A/D converter	6	11,12 (6,7)	P0.6–P0.7
INT0–INT3	I	External interrupt input pins	7	14–17 (9–11)	P1.0–P1.3
T0	O	Timer 0 output (interval, PWM)	2	7 (2)	P2.6
T0CK	I	Timer 0 clock input	3	8 (3)	P1.7
OSDHT	O	Half-tone control signal output for OSD	2	21 (16)	P2.7
Vblue, Vgreen Vred	O	Digital blue, green and red signal outputs for OSD	4	22–24 (17–19)	–
Vblank	O	Digital video blank signal outputs for OSD	4	25 (20)	–
H-sync, V-sync	I	H-sync, V-sync input for OSD	1	26, 27 (21,22)	–
OSC _{IN} , OSC _{OUT}	I, O	L-C oscillator pins for OSD clock frequency generation	–	28, 29 (23,24)	–
X _{IN} , X _{OUT}	I, O	System clock pins	–	31, 32 (27,28)	–
nRESET	I	System reset input pin	8	33 (29)	–
TEST	–	Test Pin (must be connected to V _{SS}). Factory test mode is activated when 12 V is applied.	–	13 (8)	–
V _{DD} , V _{SS}	–	Power supply pins	–	30, 34, 37 (26,30,34)	–
CAPA	I	Input for capture A module	1	36 (32)	–

NOTE: Parentheses indicate pin number for 44-QFP package.

PIN CIRCUITS

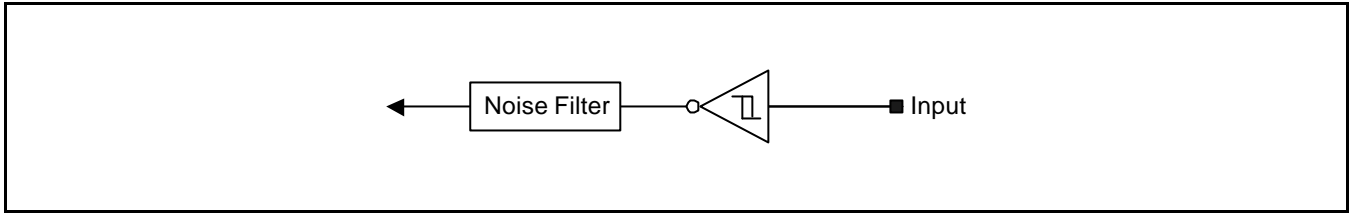


Figure 1-4. Pin Circuit Type 1 (V-Sync H-Sync, CAPA)

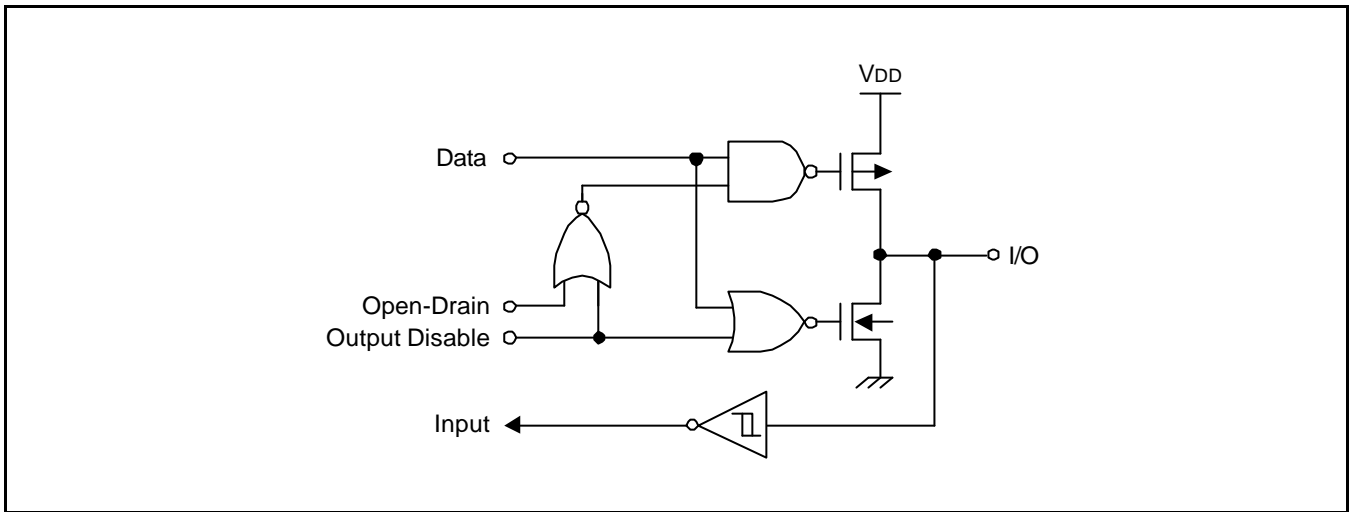


Figure 1-5. Pin Circuit Type 2 (P2.0-P2.7, P0.0-P0.3, PWM0-PWM5, T0, OSDHT)

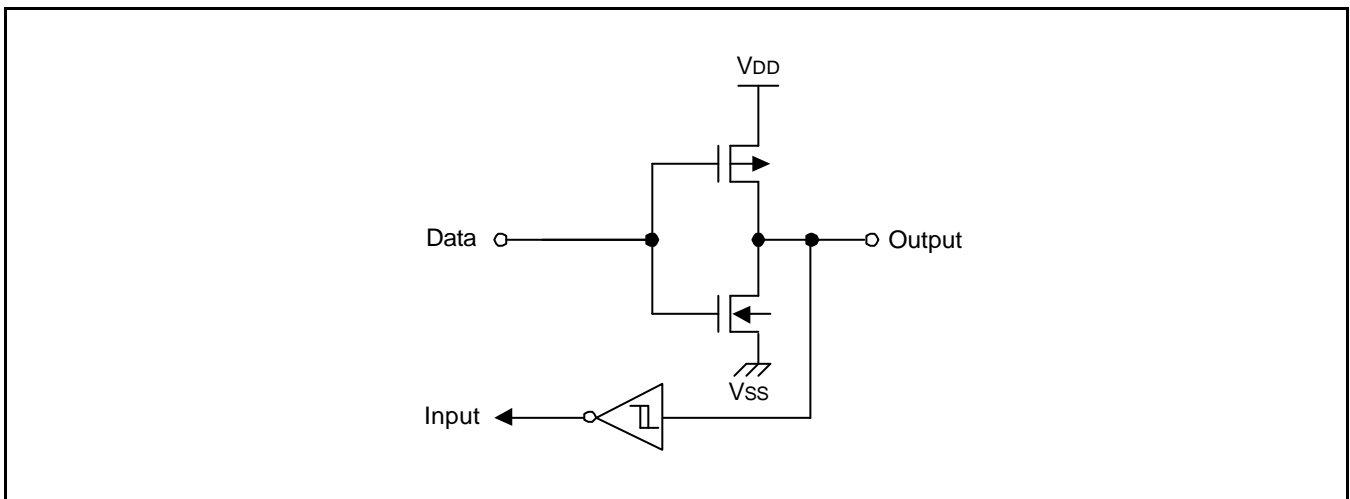


Figure 1-6. Pin Circuit Type 3 (P0.4-P0.5, P1.6-P1.7, T0CK)

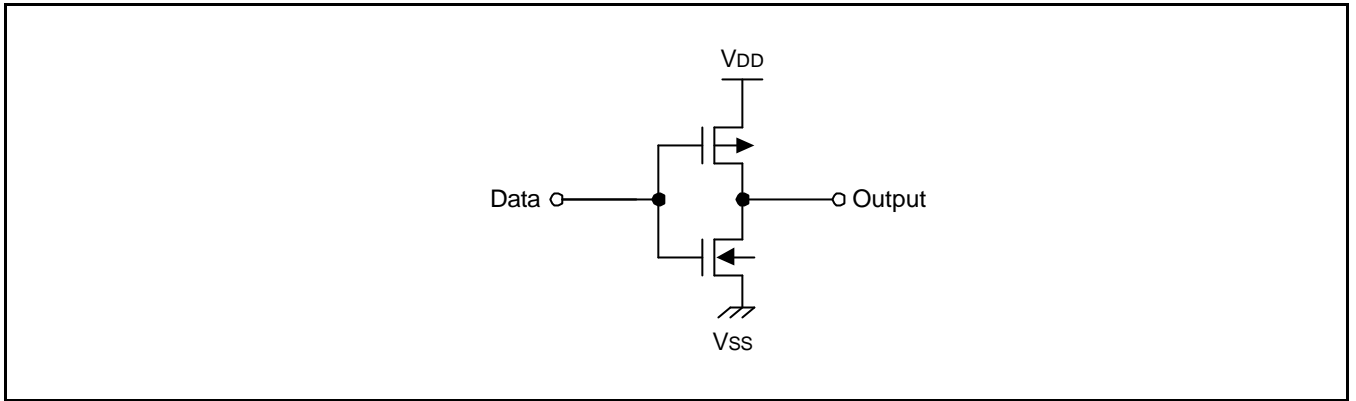


Figure 1-7. Pin Circuit Type 4 (Vblue, Vgreen, Vred, Vblank)

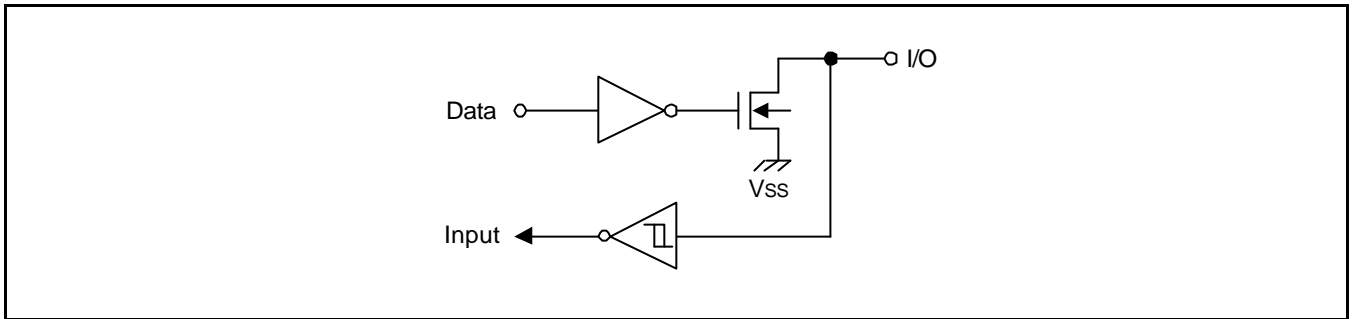


Figure 1-8. Pin Circuit Type 5 (P1.4–P1.5)

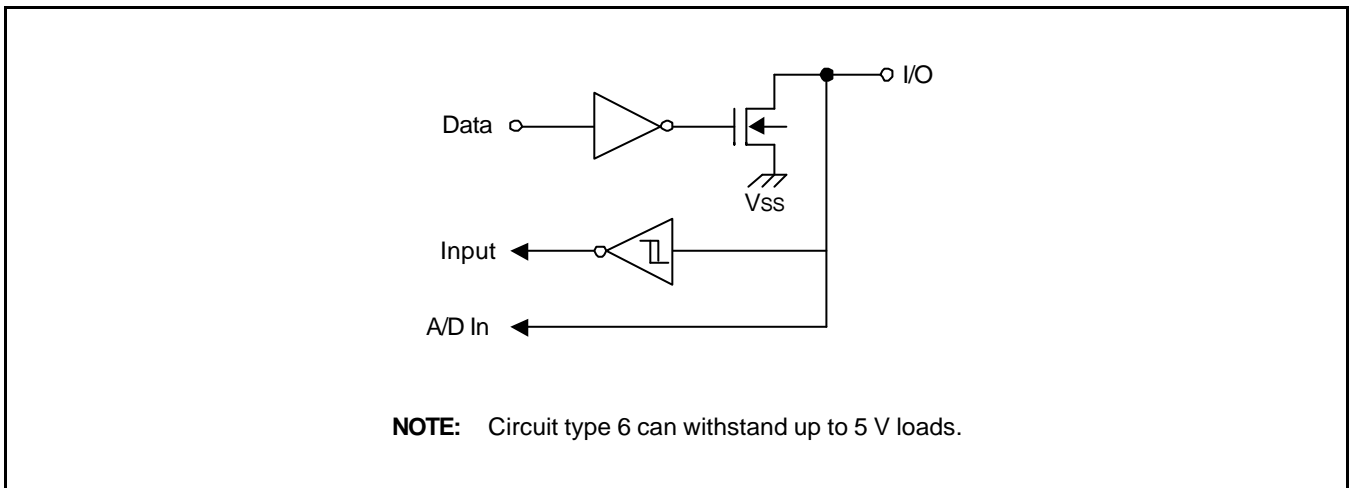


Figure 1-9. Pin Circuit Type 6 (P3.0–P3.1, P0.6–P0.7, ADC0–ADC3)

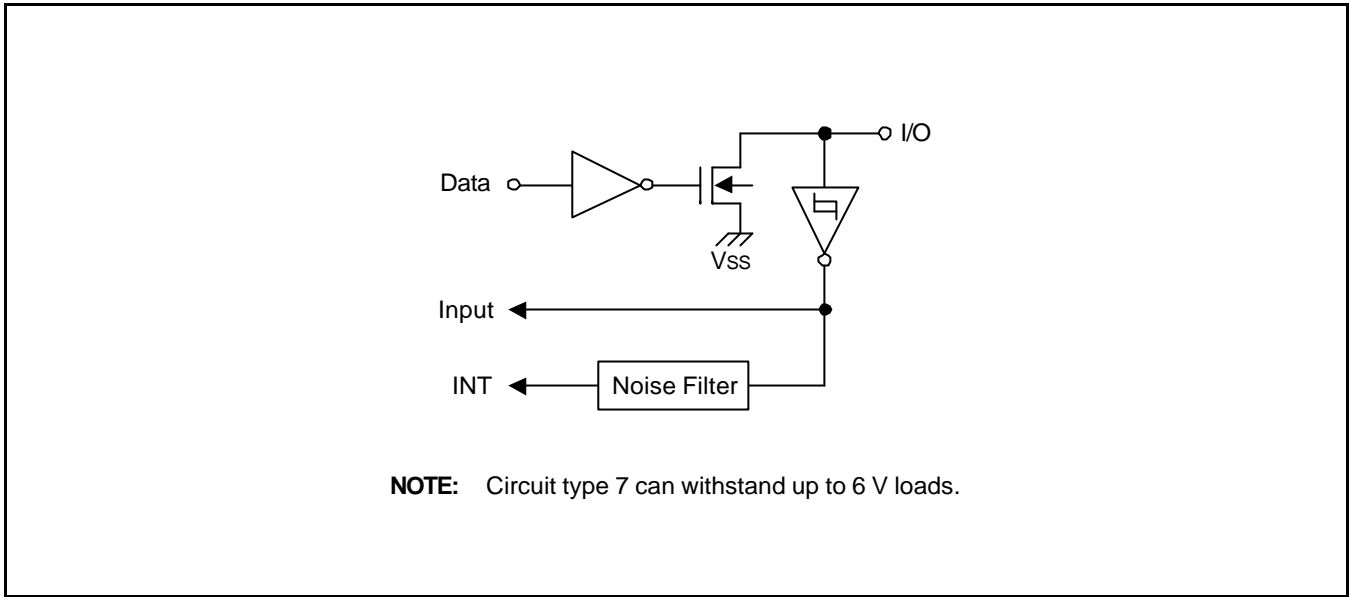


Figure 1-10. Pin Circuit Type 7 (P1.0-P1.3, INT0-INT3)

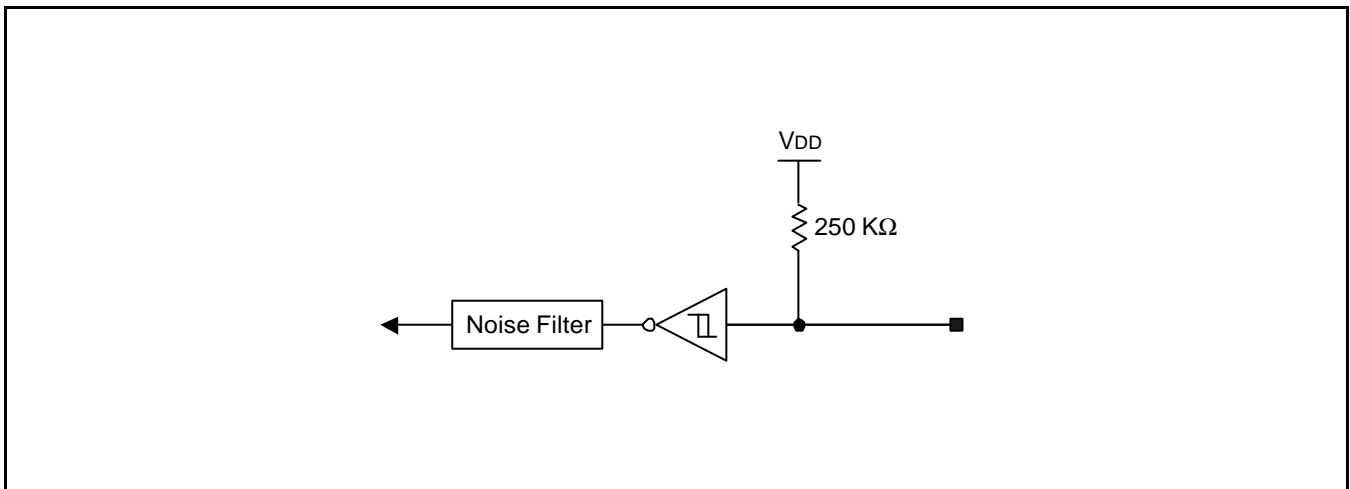


Figure 1-11. Pin Circuit Type 8 (nRESET)

2 ADDRESS SPACES

OVERVIEW

The S3C880A/F880A microcontroller has two kinds of address space:

- Internal program memory (ROM)
- Internal register file

The S3C880A/F880A has an on-chip 48-Kbyte mask-programmable.

There are 336 general-purpose 8-bit data registers in the register file. Seventeen 8-bit registers are used for CPU and system control. To support peripheral, I/O, and clock functions, there are 33 control registers and 16 data registers. In addition, there is a 252×4 -bit area for on-screen display (OSD) video RAM.

PROGRAM MEMORY (ROM)

The S3C880A/F880A has a 48-Kbyte mask-programmable program memory. Program memory stores program codes, table data or OSD font codes.

As shown in Figure 2-1, the first 256 bytes of the ROM (0H–0FFH) are reserved for interrupt vector addresses. Unused locations in this range can be used as normal program memory. If the vector address area is used to store normal program data, care must be taken to avoid overwriting vector addresses stored in these locations. The ROM address at which program execution starts after a nRESET is 0100H.

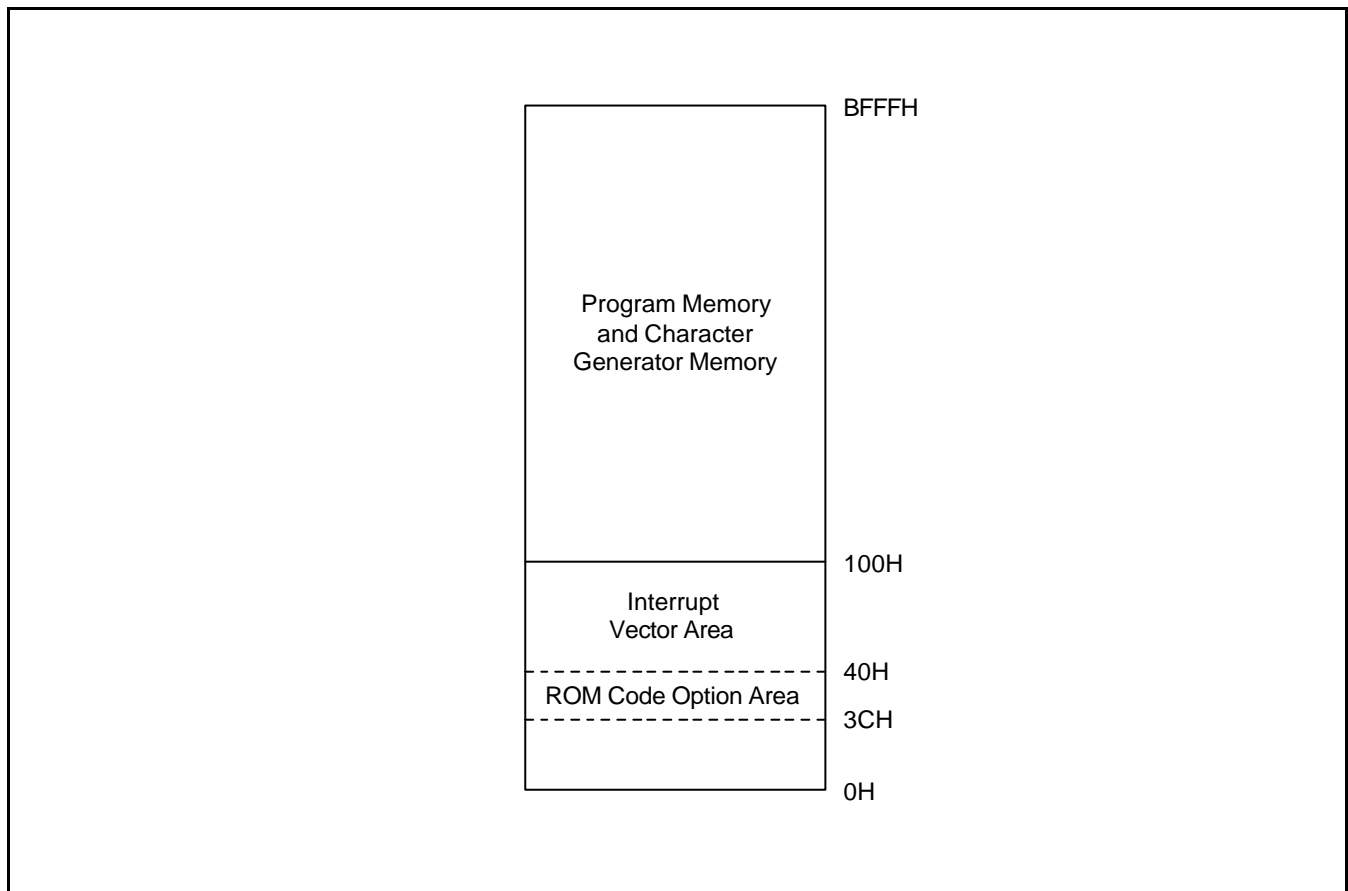


Figure 2-1. Program Memory Address Spaces

Table 2-1. Program ROM and Character ROM Area by the Font Figure

Font	ROM	Program ROM	Character ROM
0	ROM size	48-Kbyte	0-Kbyte
	ROM address	0-BFFFH	0
256	ROM size	39-Kbyte	9-Kbyte
	ROM address	0-9BFFFH	9C00H-BFFFH
384	ROM size	34.5-Kbyte	13.5-Kbyte
	ROM address	0-89FFFH	8A00H-BFFFH
512	ROM size	30-Kbyte	18-Kbyte
	ROM address	0-77FFFH	7800H-BFFFH
640	ROM size	25.5-Kbyte	22.5-Kbyte
	ROM address	0-65FFFH	6600H-BFFFH
768	ROM size	21-Kbyte	27-Kbyte
	ROM address	0-53FFFH	5400H-BFFFH
1024	ROM size	12-Kbyte	36-Kbyte
	ROM address	0-2FFFH	3000H-BFFFH

REGISTER ARCHITECTURE

The upper 64 bytes of the S3C880A/F880A internal register file is logically expanded into two 64-byte areas, called *set 1* and *set 2*. The upper 32-byte area of set 1 is divided into two register banks, called *bank 0* and *bank 1*. In addition, two register pages are implemented, called *page 0* and *page 1*. The total addressable register space is thereby expanded from 256 bytes to 654 bytes.

The extension of the physical register space into separately addressable areas (sets, banks, and pages) is supported by various addressing mode restrictions, the select bank instructions, SB0 and SB1, and the register page pointer (PP).

Specific register types and the area (in bytes) that they occupy in the register file are summarized in Table 2-1.

Table 2-2. Register Type Summary

Register Type	Number of Bytes
General-purpose registers (including the 16-byte working register common area)	336
CPU and system control registers	17
Peripheral, I/O, and clock control/data registers	49
On-screen display (OSD) video RAM	252
Total Addressable Bytes	654

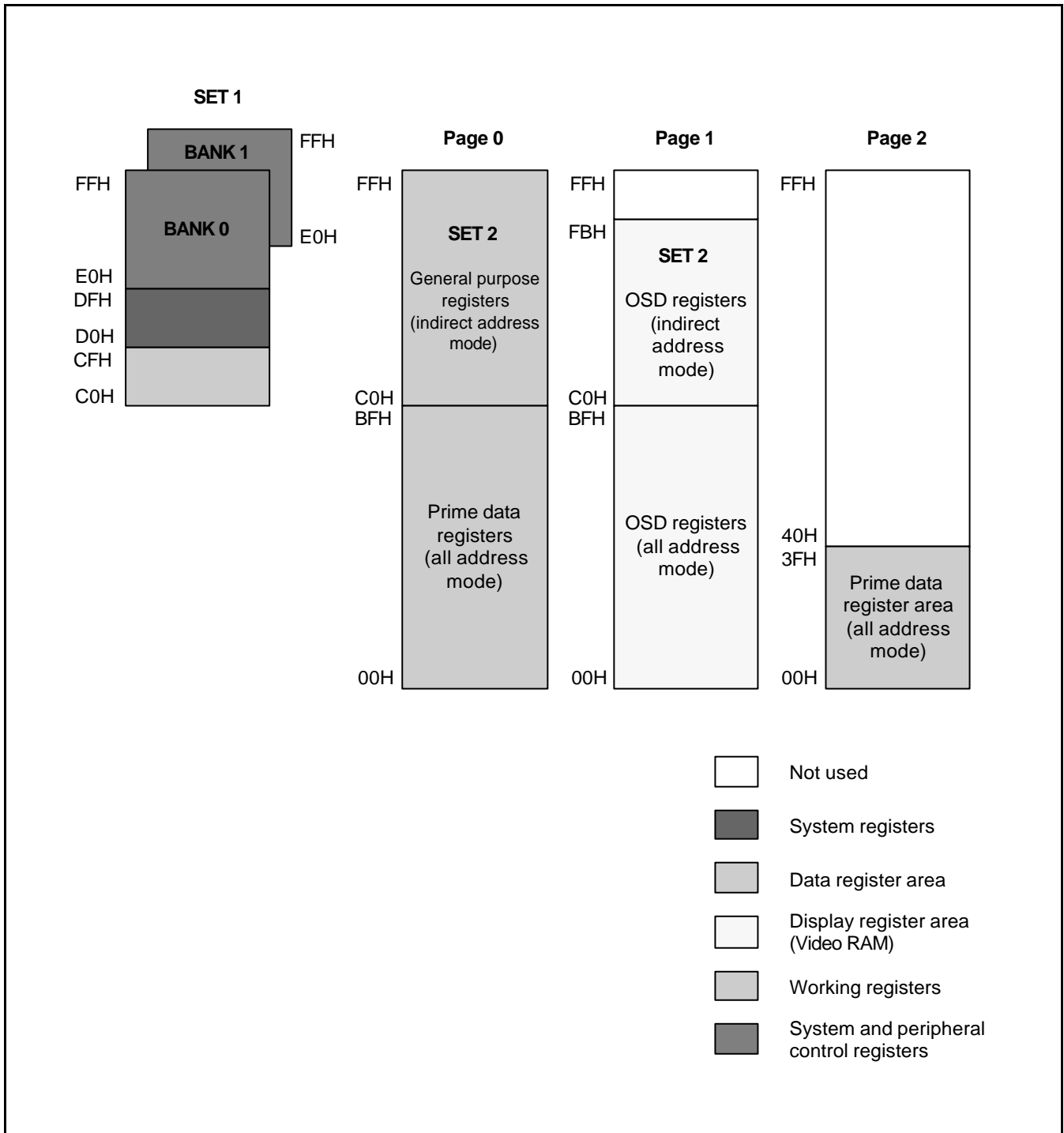


Figure 2-2. Internal Register File Organization

ROM CODE OPTION (RCOD_OPT)

The address of RCODE_OPT, from 3CH to 3FH, are ROM code option area. By setting the value of RCODE_OPT, S3C880A/F880A operates optionally. But in S3C880A/F880A, the ROM code option is not available. So RCODE_OPT area can be used as the normal ROM area in S3C880A/F880A.

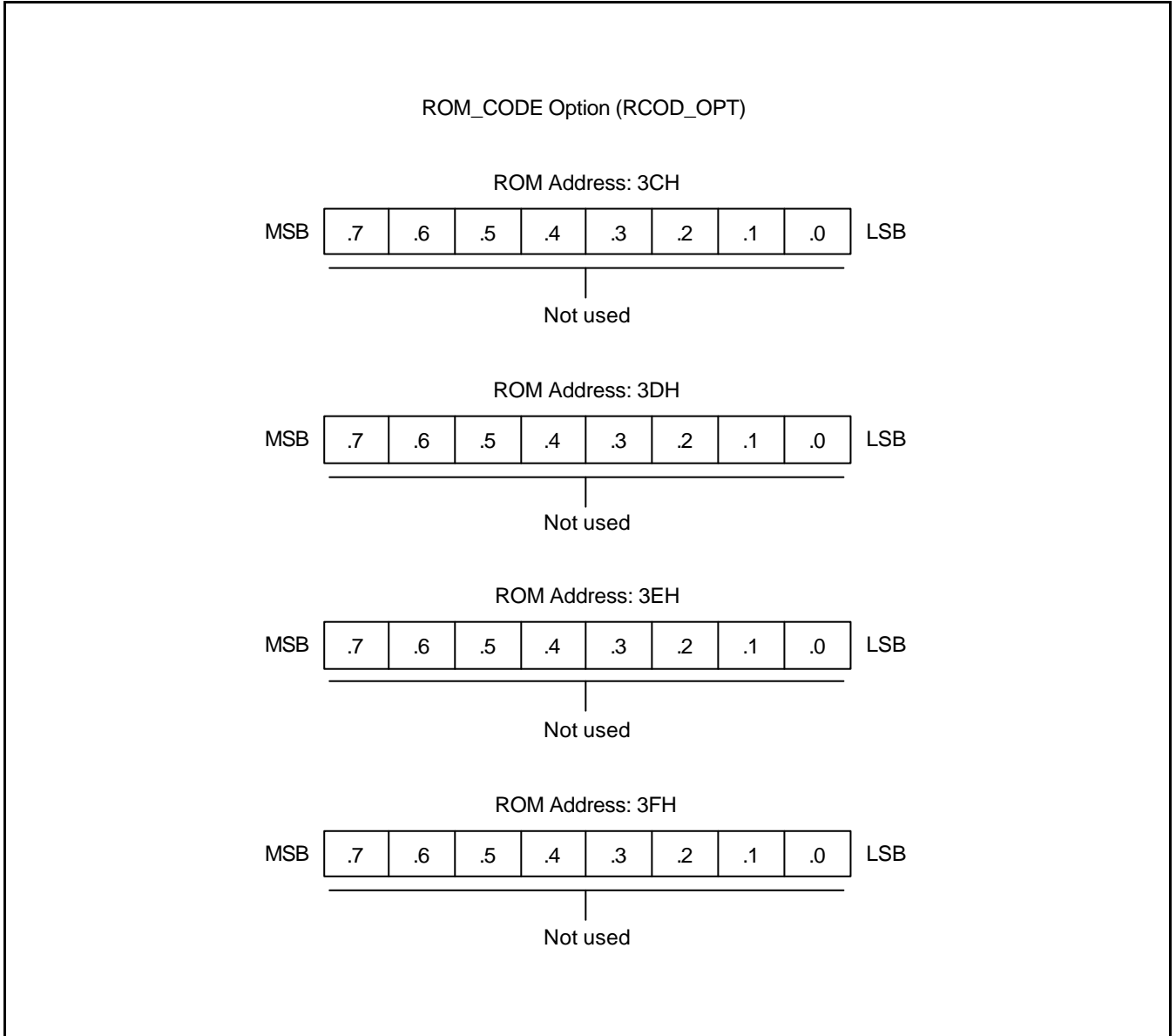


Figure 2-3. ROM Code Option (RCOD_OPT)

REGISTER PAGE POINTER (PP)

The SAM88LP architecture supports the logical expansion of the physical 256-byte register file in up to 16 separately addressable register pages. Page addressing is controlled by the register page pointer, PP, DFH. Only two pages are implemented in the S3C880A/F880A microcontrollers: page 0 and page 2 (00H–3FH) are used as general-purpose register space and page 1 contains a 252 × 4-bit area for the on-screen display (OSD) video ROM.

As shown in Figure 2-3, when the upper nibble of the PP register is '0000B', the selected destination address is located on page 0. When the upper nibble value is '0001B', page 1 is the selected destination. The lower nibble of the page pointer controls the source register page destination addressing: when the lower nibble is '0000B', page 0 is the selected source register page; when the lower nibble is '0001B', page 1 is the source register page.

After a reset, the page pointer's source value (the lower nibble) and the destination value (the upper nibble) are always '0000B', automatically selecting page 0 as both the source and the destination. To select page 1 as the source or destination register page, you must modify the register page pointer values accordingly. Because only page 0, page 1 and page 2 are used in the S3C880A/F880A implementation, only pointer values '0000B', '0001B' and '0010B' are used.

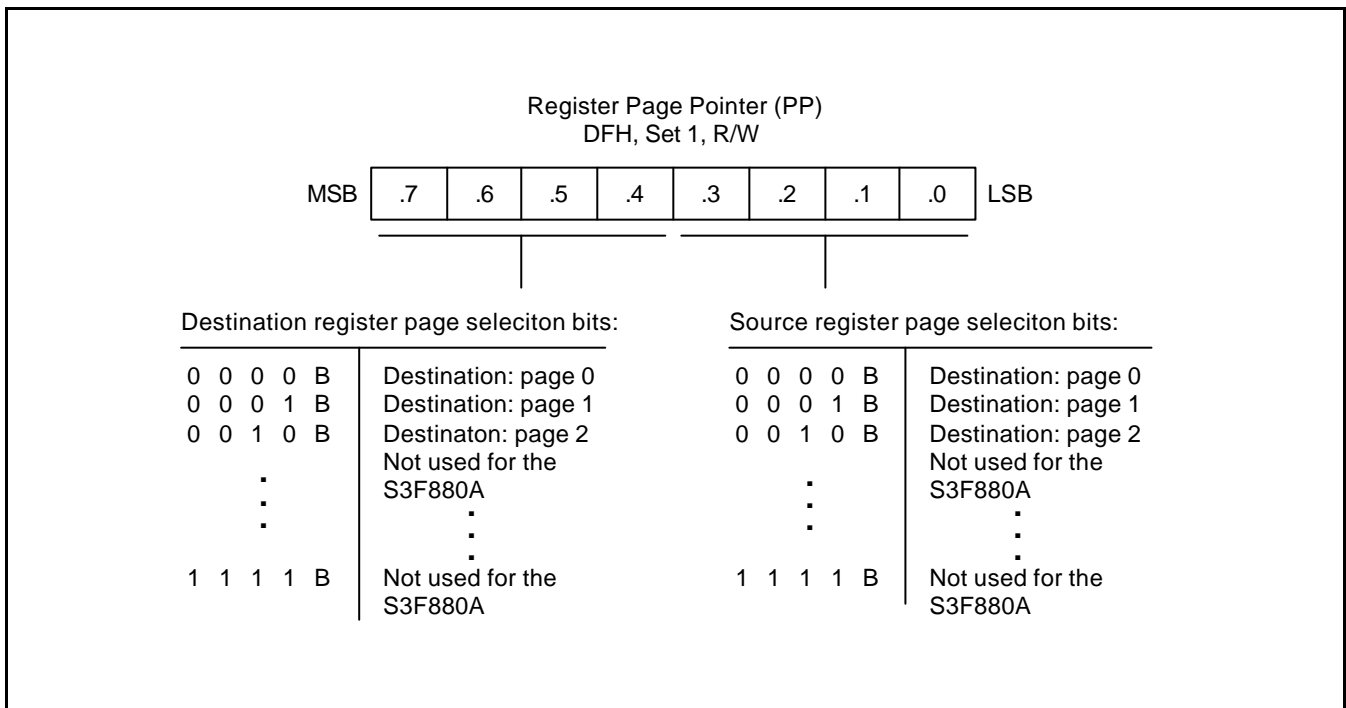


Figure 2-4. Register Page Pointer (PP)

PROGRAMMING TIP – Data Operations Between Register Pages

```

LD      PP,#10H      ; Destination register page 1, source register page 0
LD      20H,45H      ; Register 20H in page 1 ← Content of the register 45H
                    ; in page 0
.
.
.
ADD     30H,40H      ; Register 30H in page 1 ← Content of 30H in page 1
                    ; plus (+) the content of 40H in page 0
    
```

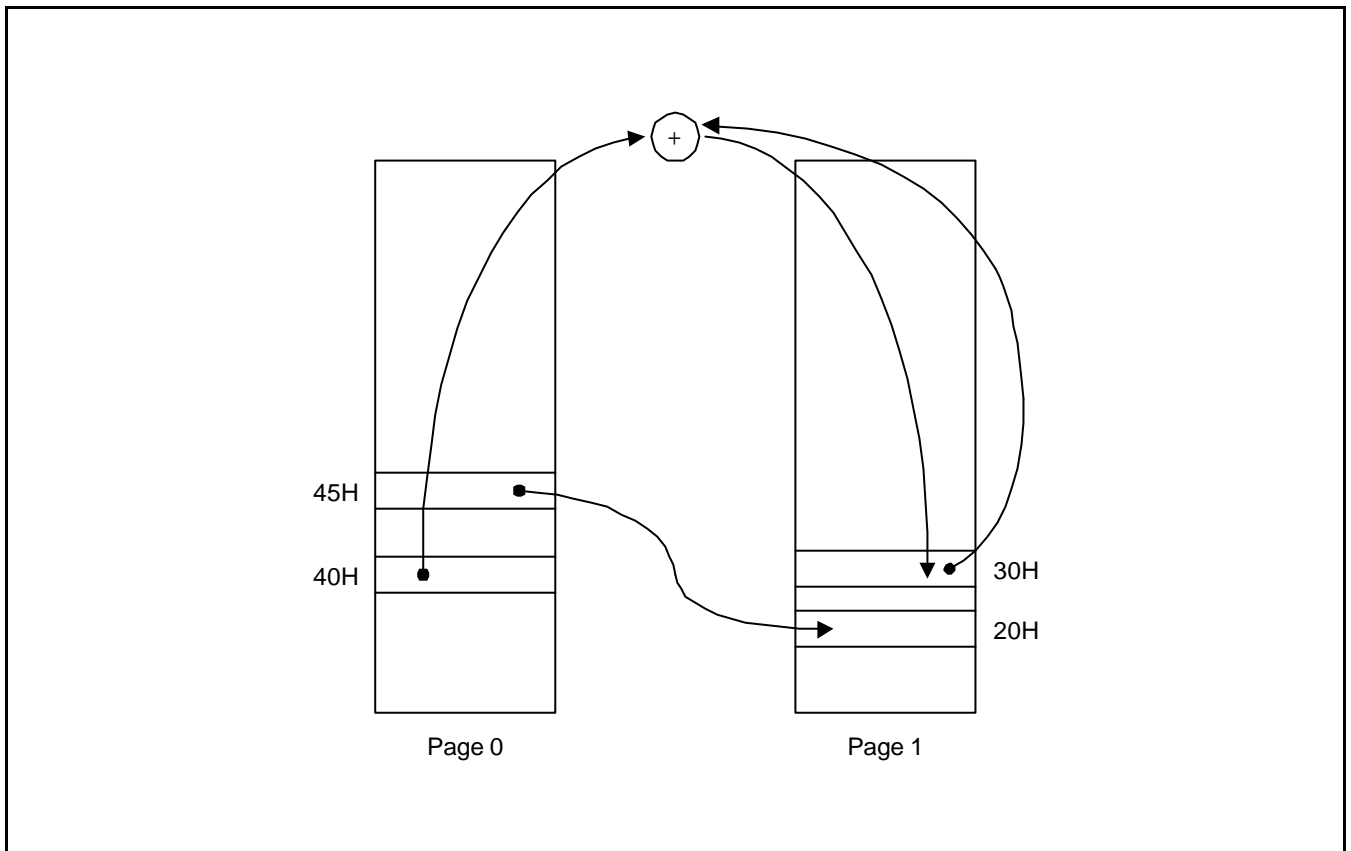


Figure 2-5. Programming Tip Example for Inter-Page Data Operations

EFFECT OF DIFFERENT INSTRUCTIONS FOR INTER-PAGE DATA OPERATIONS

The source and the destination pages for data operations between pages differ, depending on which instruction you use. The following programming tip, "Examples of Inter-Page Data Transfer Operations," provides you with a detailed list of various case.

 **PROGRAMMING TIP – Examples of Inter-Page Data Transfer Operations**

Example 1.	a)	ADC	R1,R0	; R0 – source page ; R1 – destination page
	b)	ADC	R4,@R2 R2 contains 40H	; R2, 40H – source page ; R4 – destination page
	c)	ADC	R0,#0AAH	; R0 – destination page
	d)	ADC	40H,42H	; 42H – source page ; 40H – destination page
	e)	ADC	40H,@42H 42H contains 60H	; 42H, 60H – source page ; 40H – destination page
	f)	ADC	40H,#02H	; 40H – destination page

NOTE: The above examples also apply to the instructions ADD, SUB, AND, OR, and XOR.

Example 2.	a)	BAND	R0,40H.7	; 40H – source page ; R0 – destination page
	b)	BAND	40H.7,R0	; R0 – source page ; 40H – destination page

NOTE: The above examples also apply to the instructions BOR, BXOR, and LDB.

Example 3.	a)	BCP	R3,44H.7	; 44H – source page ; R3 – destination page
-------------------	----	-----	----------	--

Example 4.	a)	BITC	R3.7	; R3 – destination page
-------------------	----	------	------	-------------------------

NOTE: The above examples also apply to the instructions BITR and BITS.

 **PROGRAMMING TIP – Examples of Inter-Page Data Transfer Operations (continued)**

Example 5. a) BTJRF SKIP,R6.7 ; R6 – source page

NOTE: The above example also applies to the instructions BTJRT.

Example 6. a) CALL @60H ; 60H, 61H – source page

Example 7. a) CLR 30H ; 30H – destination page

b) CLR @44H ; 44H – source page
44H contains 40H ; 40H – destination page

NOTE: The above examples also apply to the instructions RL, RLC, and SRA.

Example 8. a) COM 03H ; 03H – destination page

b) COM @44H ; 44H – source page
44H contains 40H ; 40H – destination page

NOTE: The above examples also apply to the instructions DEC, INC, RR, and RRC.

Example 9. a) CP R1,R0 ; R0 – source page
; R1 – destination page

b) CP R2,@R4 ; R4, 40H – source page
R4 contains 40H ; R2 – destination page

c) CP 40H,42H ; 42H – source page
; 40H – destination page

d) CP 40H,@42H ; 42H, 44H – source page
42H contains 44H ; 40H – destination page

e) CP 20H,#0AAH ; 20H – destination page

NOTE: The above examples also apply to the instructions TCM and TM.

 **PROGRAMMING TIP – Examples of Inter-Page Data Transfer Operations (Continued)**

Example 16.	a)	LD	R0,#0AAH	;	R0 – destination page
	b)	LD	R0,40H	;	40H – source page
				;	R0 – destination page
	c)	LD	40H,R0	;	R0 – source page
				;	40H – destination page
	d)	LD	R0,@R2	;	R2, 50H – source page
			R2 contains 50H	;	R0 – destination page
	e)	LD	@R4,R2	;	R4, R2 – source page
			R4 contains 40H	;	40H – destination page
	f)	LD	40H,41H	;	41H – source page
				;	40H – destination page
	g)	LD	40H,@42H	;	42H, 44H – source page
			42H contains 44H	;	40H – destination page
	h)	LD	45H,#02H	;	45H – destination page
	i)	LD	@40H,#02H	;	40H – source page
			40H contains 44H	;	44H – destination page
	j)	LD	@40H,42H	;	40H, 42H – source page
			40H contains 44H	;	44H – destination page
	k)	LD	R5,#04H(R0)	;	R0, 04H(2 + offset) – source page
			R0 contains 02H	;	R5 – destination page
	l)	LD	#04H(R0),R1	;	R0, R1 – source page
			R0 contains 02H	;	04H – destination page

 **PROGRAMMING TIP – Examples of Inter-Page Data Transfer Operations (Continued)**

- Example 17.**
- | | | | |
|----|-----|--|---|
| a) | LDC | R0,@RR6 | ; R6, R7 – source page
; R0 – destination page |
| b) | LDC | @RR6,R2
RR6 contains an external memory address | ; R6, R7, R2 – source page |
| c) | LDC | R0,#01H(RR6) | ; R6, R7 – source page
; R0 – destination page |
| d) | LDC | #01H(RR6),R0 | ; R0, R6, R7 – source page |
| e) | LDC | R0,#1000H(RR6) | ; R6, R7 – source page
; R0 – destination page |
| f) | LDC | #1000H(RR6),R0 | ; R0, R6, R7 – source page |

- Example 18.**
- | | | | |
|----|-------|---------|---|
| a) | LDCD | R0,@RR6 | ; R6, R7 – source page
; R0 – destination page |
| b) | LDCPD | @RR6,R0 | ; R0, R6, R7 – source page |

NOTE: The above examples also apply to the instructions LDCI and LDCPI.

- Example 19.**
- | | | | |
|----|-----|------------------------------|---|
| a) | LDW | 40H,20H | ; 20H, 21H – source page
; 40H, 41H – destination page |
| b) | LDW | 60H,@20H
20H contains 40H | ; 20H, 40H – source page
; 60H, 61H – destination page |
| c) | LDW | 40H,#02H | ; 40H, 41H – destination page |

 **PROGRAMMING TIP – Examples of Inter-Page Data Transfer Operations (Concluded)**

- Example 20.** a) MULT 40H,20H ; 20H – source page
; 40H, 41H – destination page
- b) MULT 60H,@20H ; 20H, 40H – source page
20H contains 40H ; 60H, 61H – destination page
- c) MULT 40H,#02H ; 40H, 41H – destination page
- Example 21.** a) POP 00H ; 00H – destination page
- b) POP @20H ; 20H – source page
20H contains 40H ; 40H – destination page
- Example 22.** a) POPUD 00H,@20H ; 20H, 40H – source page
20H contains 40H ; 00H – destination page

NOTE: The above example also applies to the instruction POPUI.

- Example 23.** a) PUSH 00H ; 00H – destination page
- b) PUSH @20H ; 20H, 40H – source page
20H contains 40H
- Example 24.** a) PUSHUD @60H,20H ; 60H, 20H – source page
60H contains 44H ; 44H – destination page

NOTE: The above example also applies to the instruction PUSHUI.

- Example 25.** a) SWAP 00H ; 00H – destination page
- b) SWAP @20H ; 20H – source page
20H contains 40H ; 40H – destination page

REGISTER SET 1

The term *set 1* refers to the upper 64 bytes of the register file, locations C0H–FFH. This area can be accessed at any time, regardless of which page is currently selected. The upper 32-byte area of this 64-byte space is divided into two 32-byte register banks, called *bank 0* and *bank 1*. You use the select register bank instructions, SB0 or SB1, to address one bank or the other. A reset operation automatically selects bank 0 addressing.

The lower 32-byte area of set 1 is not banked. This area contains 16 bytes for mapped system registers (D0H–DFH) and a 16-byte common area (C0H–CFH) for working register addressing.

Registers in set 1 are directly accessible at all times using Register addressing mode. The 16-byte working register area, however, can only be accessed using working register addressing. Working register addressing is a function of Register addressing mode (see Chapter 3, "Addressing Modes," for more information).

REGISTER SET 2

The same 64-byte physical space that is used for the set 1 register locations C0H–FFH is logically duplicated to add another 64 bytes. This expanded area of the register file is called *set 2*. The logical division of set 1 and set 2 is maintained by means of addressing mode restrictions: while you can access set 1 using Register addressing mode only, you should use Register Indirect addressing mode or Indexed addressing mode to access set 2.

For the S3C880A/F880A, the set 2 address range (C0H–FFH) is accessible on page 0 and page 1. Please note, however, that on page 1, the set 2 locations FCH–FFH are not mapped.

Part of the OSD video RAM is in page 1, set 2 (C0H–FBH), and the other part (00H–BFH) is in the page 1 prime register area. To avoid programming errors, we recommend using either Register Indirect or Indexed mode to address the entire 252-byte video RAM area.

PRIME REGISTER SPACE

The lower 192 bytes (00H–BFH) of the S3C880A/F880A's two 256-byte register pages and the 64 bytes (00H–3FH) of register page 2 are called *prime register area*. Prime registers can be accessed using any of the seven addressing modes. The prime register area on page 0 is immediately addressable after a reset. In order to address registers on page 1 (in the OSD video RAM), you must first set the register page pointer (PP) to the appropriate source and destination values.

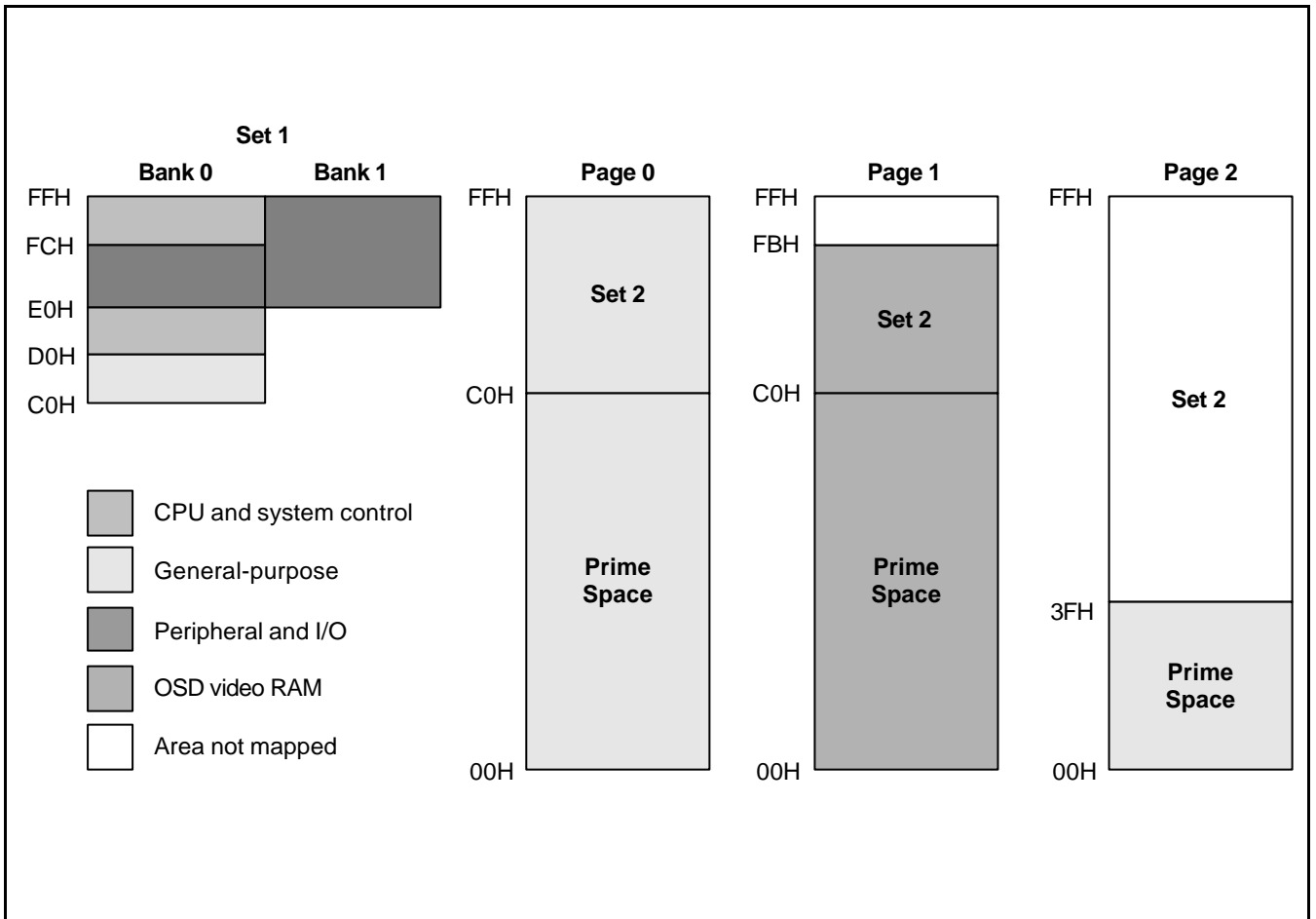


Figure 2-6. Set 1, Set 2, and Prime Area Register Map

WORKING REGISTERS

Instructions can access specific 8-bit registers or 16-bit register pairs using either 4-bit or 8-bit address fields. When 4-bit working register addressing is used, the 256-byte register file is viewed as thirty two 8-byte register groups or "slices." Each slice consists of eight 8-bit registers. When the two 8-bit register pointers, RP1 and RP0, are used, two working register slices can be selected at any time to form a 16-byte working register block. Using the register pointers, you can move this 16-byte register block anywhere in the addressable register file (except for the set 2 area).

The terms *slice* and *block* are used in this manual to help you visualize the size and relative locations of selected working register spaces:

- One working register *slice* is 8 bytes (eight 8-bit working registers; R0–R7 or R8–R15)
- One working register *block* is 16 bytes (sixteen 8-bit working registers; R0–R15)

All the registers in an 8-byte working register slice have the same binary value for their five most significant address bits. This makes it possible for each register pointer to point to one of the 24 slices in the register file. The base addresses for the two selected 8-byte register slices are contained in the register pointers, RP0 and RP1. After a reset, RP0 and RP1 always point to the 16-byte common area in set 1 (C0H–CFH).

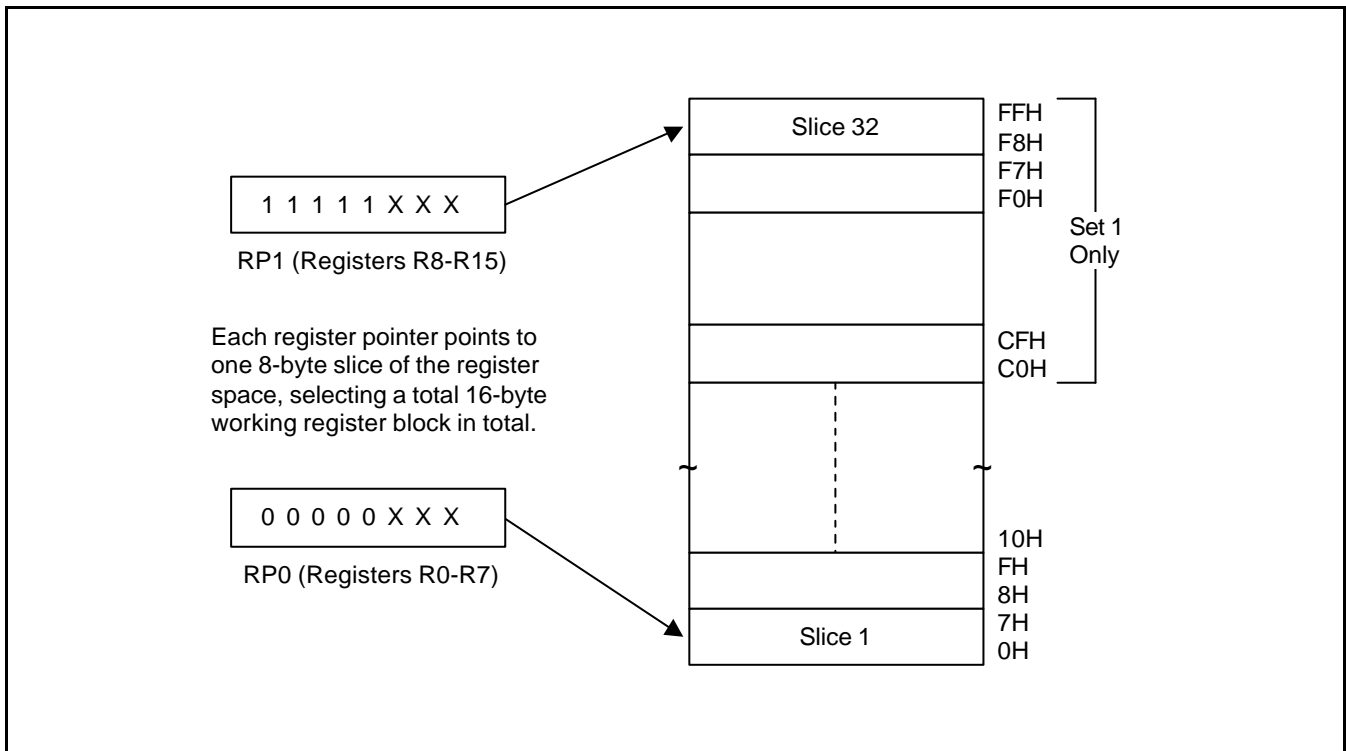


Figure 2-7. 8-Byte Working Register Areas (Slices)

USING THE REGISTER POINTERS

The register pointers, RP0 and RP1, are mapped to the addresses D6H and D7H in set 1. They are used to select two movable 8-byte working register slices in the register file. After a reset, they point to the working register common area: RP0 points to the addresses C0H–C7H, and RP1 points to the addresses C8H–CFH. If you want to change a register pointer value, you should load a new value to RP0 and/or RP1 using an SRP or LD instruction (see Figures 2-7 and 2-8).

With working register addressing, you can only access those locations that are pointed to by the register pointers. Please note that you cannot use the register pointers to select the working register area in set 2, C0H–FFH, because these locations are accessible only using the Indirect Register or Indexed addressing mode.

The selected 16-byte working register block usually consists of two contiguous 8-byte slices. As a general programming guideline, we recommend that RP0 point to the "lower" slice and RP1 point to the "upper" slice (see Figure 2-7). In some cases, it may be necessary to define working register areas in different (non-contiguous) areas of the register file. In Figure 2-8, RP0 points to the "upper" slice and RP1 to the "lower" slice.

Because a register pointer can point to either of the two 8-byte slices in the working register block, you can flexibly define the working register area.

PROGRAMMING TIP — Setting the Register Pointers

SRP	#70H	; RP0 ← 70H, RP1 ← 78H
SRP1	#48H	; RP0 ← no change, RP1 ← 48H
SRP0	#0A0H	; RP0 ← A0H, RP1 ← no change
CLR	RP0	; RP0 ← 00H, RP1 ← no change
LD	RP1,#0F8H	; RP0 ← no change, RP1 ← 0F8H

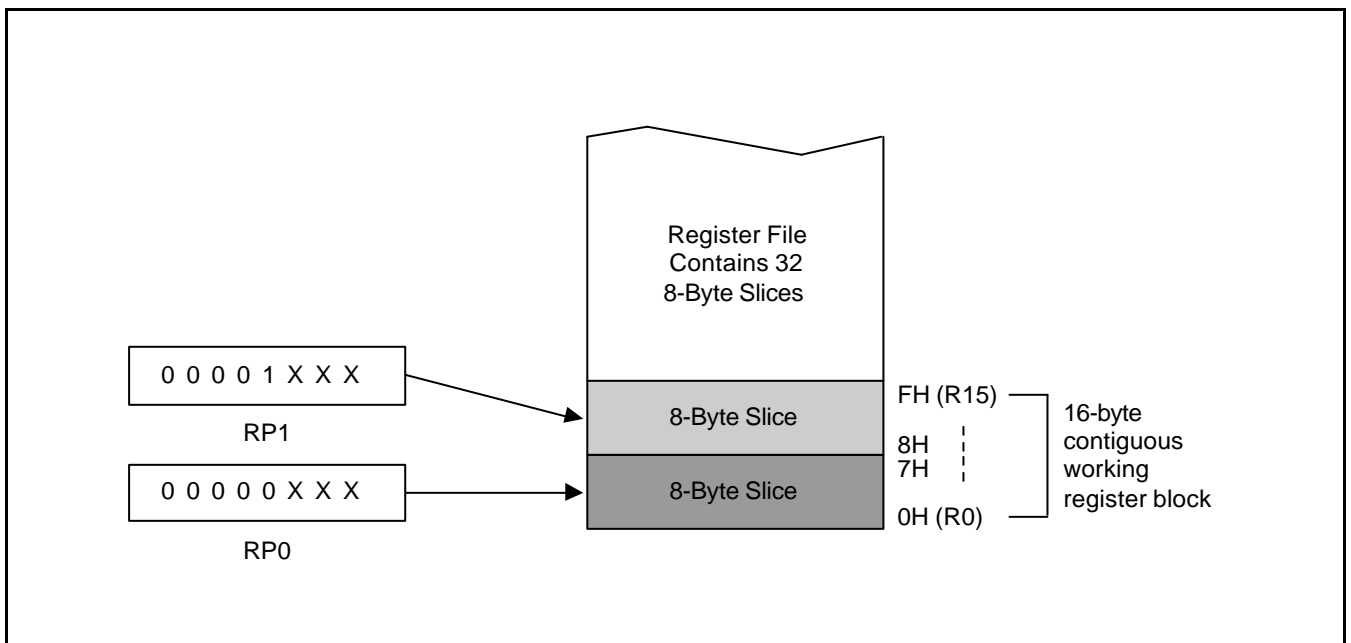


Figure 2-8. Contiguous 16-Byte Working Register Block

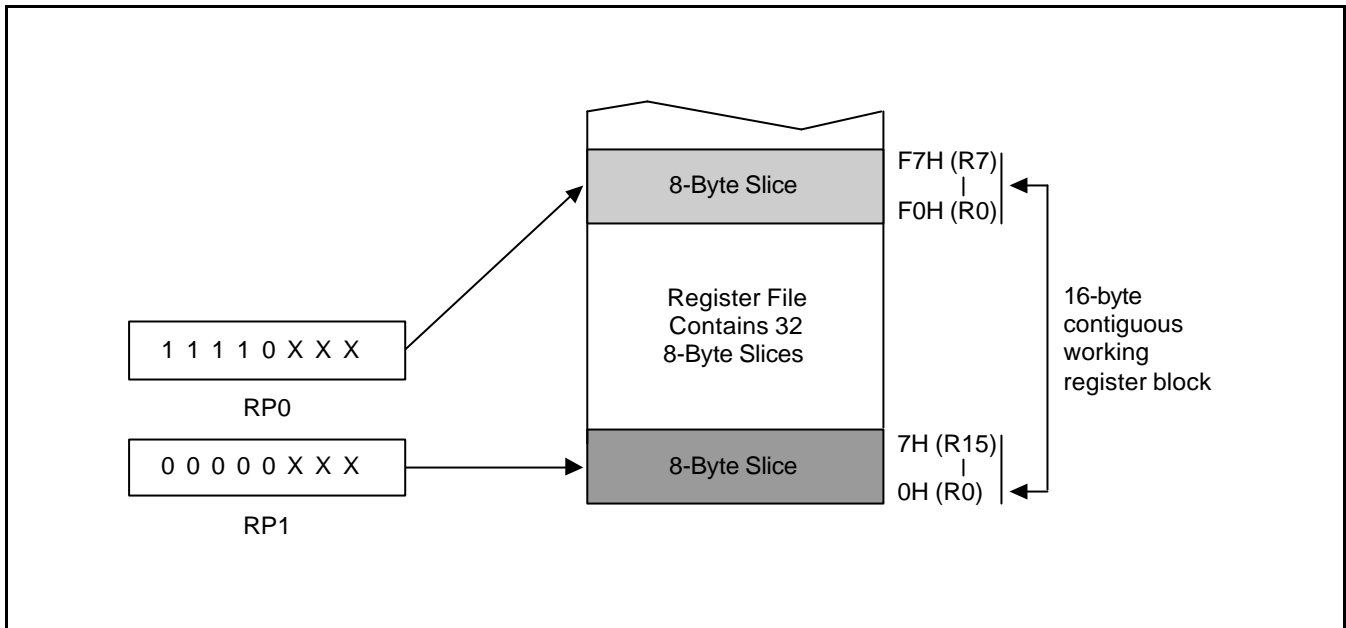


Figure 2-9. Non-Contiguous 16-Byte Working Register Block

PROGRAMMING TIP — Using the RPs to Calculate the Sum of a Series of Registers

Calculate the sum of the registers, 80H–85H, using the register pointer. The register addresses 80H through 85H contain the values 10H, 11H, 12H, 13H, 14H, and 15 H, respectively:

```

SRP0      #80H          ; RP0 ← 80H
ADD       R0,R1         ; R0 ← R0 + R1
ADC       R0,R2         ; R0 ← R0 + R2 + C
ADC       R0,R3         ; R0 ← R0 + R3 + C
ADC       R0,R4         ; R0 ← R0 + R4 + C
ADC       R0,R5         ; R0 ← R0 + R5 + C
    
```

The sum of these six registers, 6FH, is located in the register R0 (80H). The instruction string used in this example takes 12 bytes of instruction code and its execution time is 36 cycles. If you do not use the register pointer to calculate the sum of these registers, you would have to execute the following instruction sequence:

```

ADD       80H,81H       ; 80H ← (80H) + (81H)
ADC       80H,82H       ; 80H ← (80H) + (82H) + C
ADC       80H,83H       ; 80H ← (80H) + (83H) + C
ADC       80H,84H       ; 80H ← (80H) + (84H) + C
ADC       80H,85H       ; 80H ← (80H) + (85H) + C
    
```

Here, the sum of the six registers is also located in the register 80H. This instruction string, however, takes 15 bytes of instruction code rather than 12 bytes, and the execution time is 50 cycles rather than 36 cycles.

REGISTER ADDRESSING

The SAM8 register architecture provides an efficient method of working register addressing that takes full advantage of shorter instruction formats to reduce execution time.

Register (R) addressing mode, in which the operand value is the content of a specific register or register pair, can be used to access any location in the register file except for set 2.

For working register addressing, the register pointers, RP0 and RP1, are used to select a specific register within a selected 16-byte working register area. To increase the speed of context switches in an application program, the register pointers can be used to dynamically select different 8-byte "slices" of the register file as the active working register space.

Registers are addressed either as a single 8-bit register or a paired 16-bit register. In 16-bit register pairs, the address of the first 8-bit register is always an even number and that of the next register is an odd number. The most significant byte of the 16-bit data is always stored in the even-numbered register; the least significant byte is always stored in the next (+ 1) odd-numbered register.

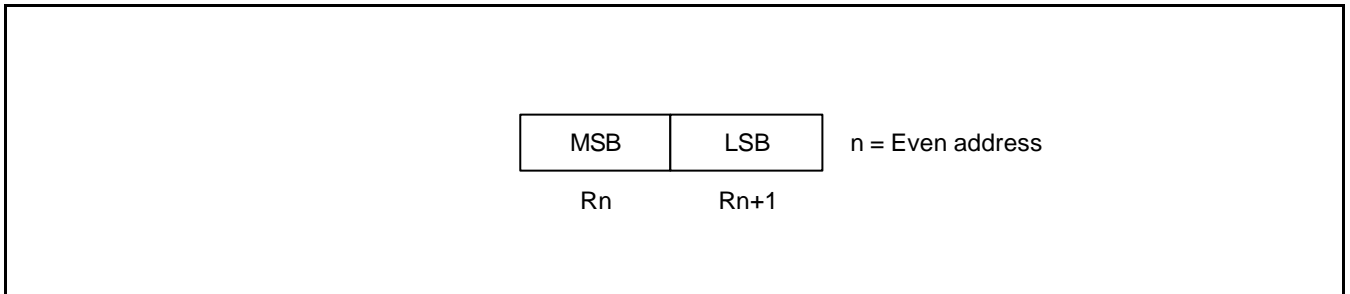


Figure 2-9. 16-Bit Register Pairs

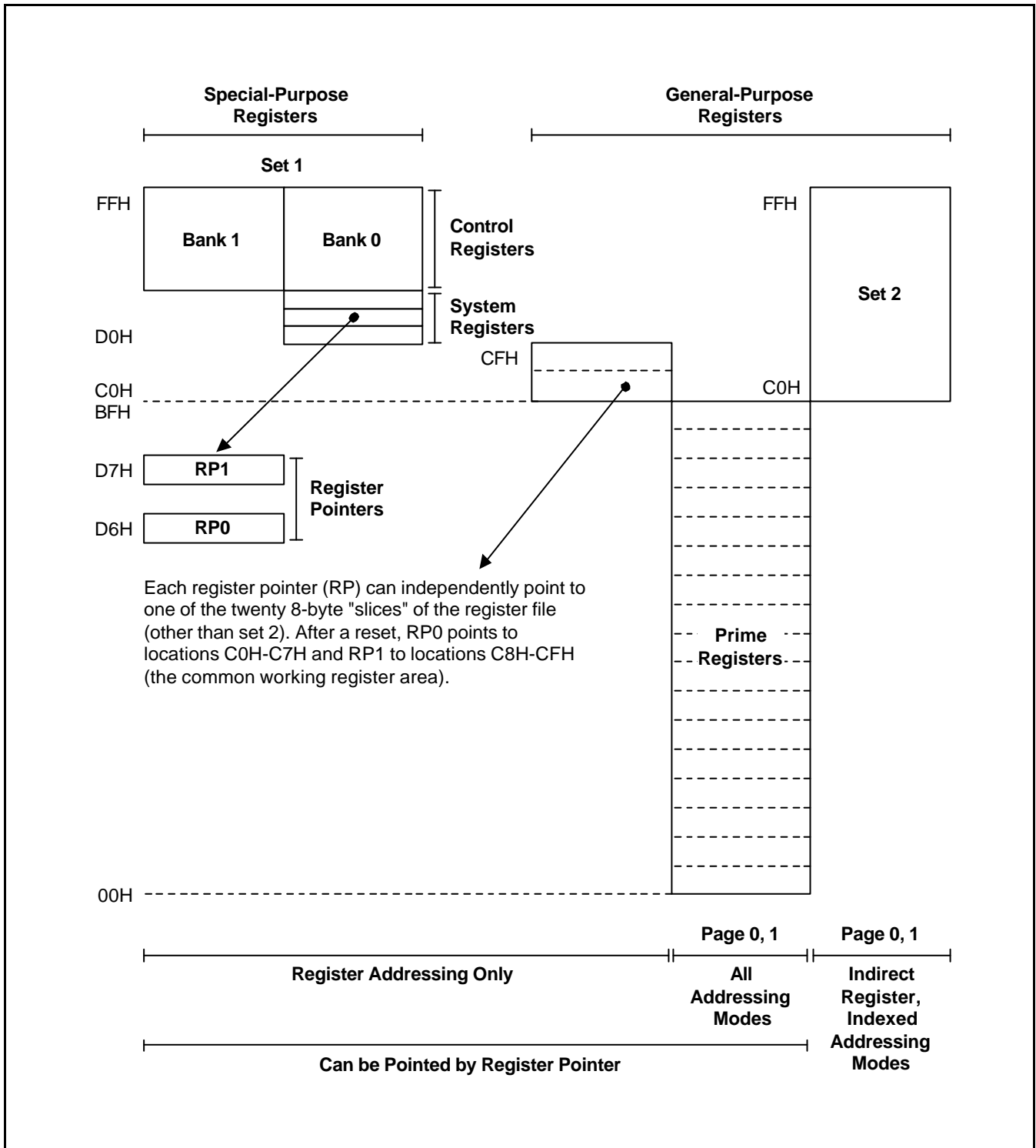


Figure 2-11. Register File Addressing

COMMON WORKING REGISTER AREA (C0H–CFH)

After a reset, the register pointers, RP0 and RP1, automatically point to two 8-byte register slices in set 1, locations C0H–CFH, as the active 16-byte working register block:

- RP0 → C0H–C7H
- RP1 → C8H–CFH

This 16-byte address range is a *common area*. That is, locations in this area can be accessed using working register addressing only.

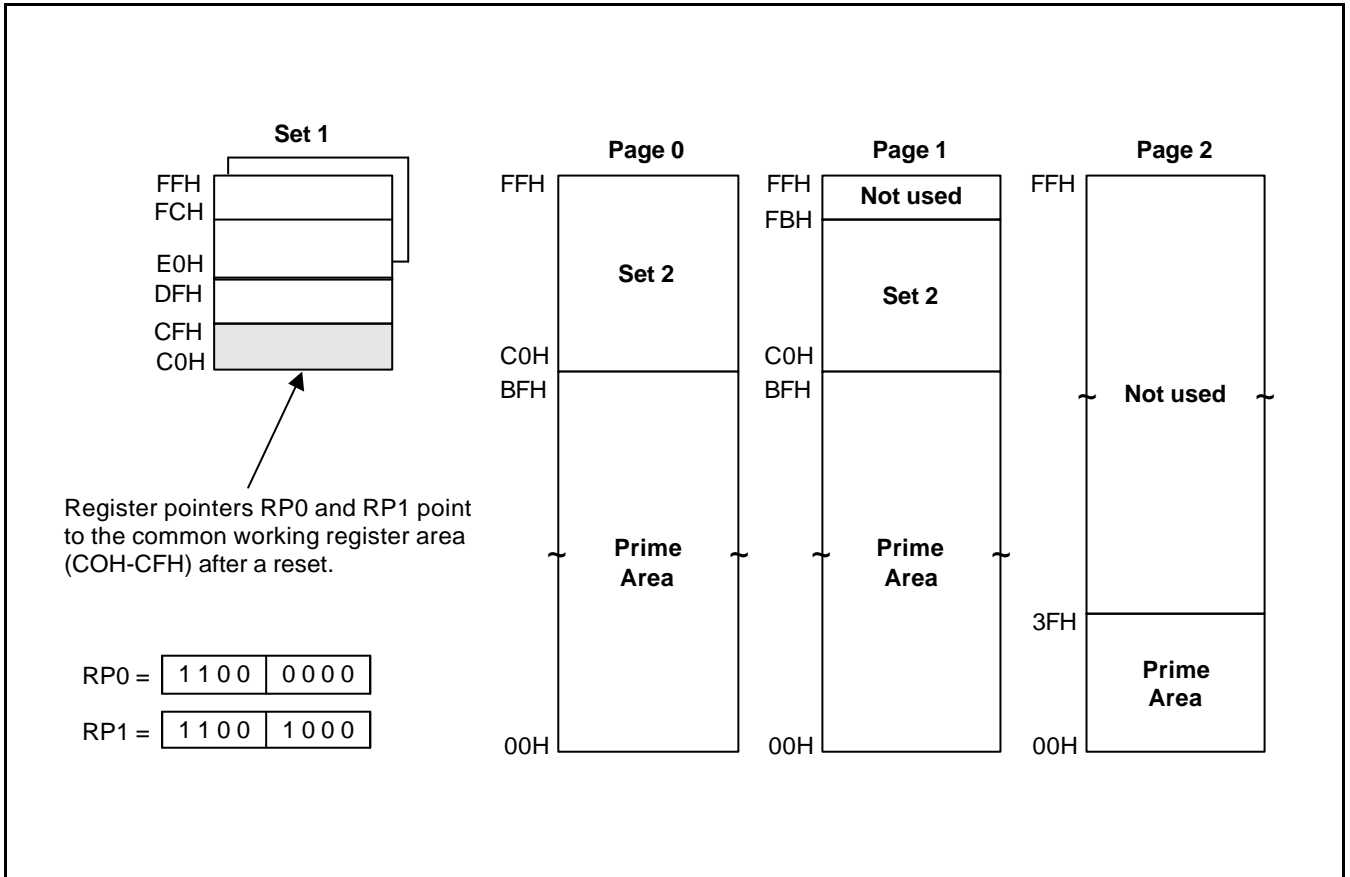


Figure 2-12. Common Working Register Area

 **PROGRAMMING TIP – Addressing the Common Working Register Area**

As the following examples show, you should access working registers in the common area, locations C0H–CFH, using working register addressing mode only.

Examples:

1. LD 0C2H,40H ; Invalid addressing mode!
 Use working register addressing instead:
 SRP #0C0H
 LD R2,40H ; R2 (C2H) ← the value in location 40H
2. ADD 0C3H,#45H ; Invalid addressing mode!
 Use working register addressing instead:
 SRP #0C0H
 ADD R3,#45H ; R3 (C3H) ← R3 + 45H

4-BIT WORKING REGISTER ADDRESSING

Each register pointer defines a movable 8-byte slice of working register space. The address information stored in a register pointer serves as an addressing "window" that enables instructions to access working registers very efficiently using short 4-bit addresses. When an instruction addresses a location in the selected working register area, the address bits are concatenated in the following way to form a complete 8-bit address:

- The high-order bit of the 4-bit address selects one of the register pointers ("0" selects RP0; "1" selects RP1);
- The five high-order bits in the register pointer select an 8-byte slice of the register space;
- The three low-order bits of the 4-bit address select one of the eight registers in the slice.

As shown in Figure 2-12, the net effect of this operation is that the five high-order bits from the register pointer are concatenated with the three low-order bits from the instruction address to form a complete address. As long as the address stored in the register pointer remains unchanged, the three bits from the address will always point to an address in the same 8-byte register slice.

Figure 2-13 shows a typical example of 4-bit working register addressing: the high-order bit of the instruction 'INC R6' is "0", which selects RP0. The five high-order bits stored in RP0 (01110B) are concatenated with the three low-order bits of the instruction's 4-bit address (110B) to produce the register address 76H (01110110B).

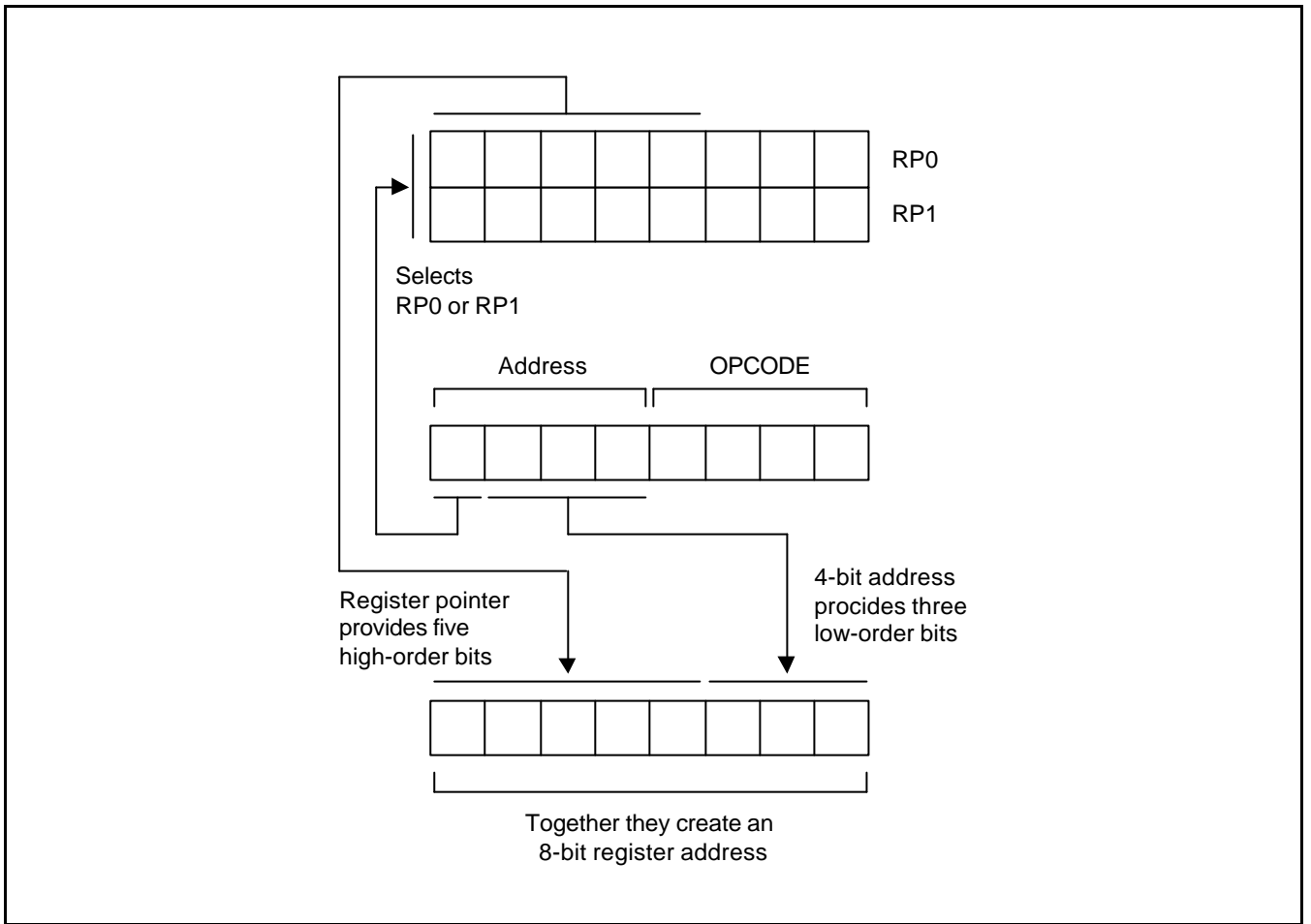


Figure 2-13. 4-Bit Working Register Addressing

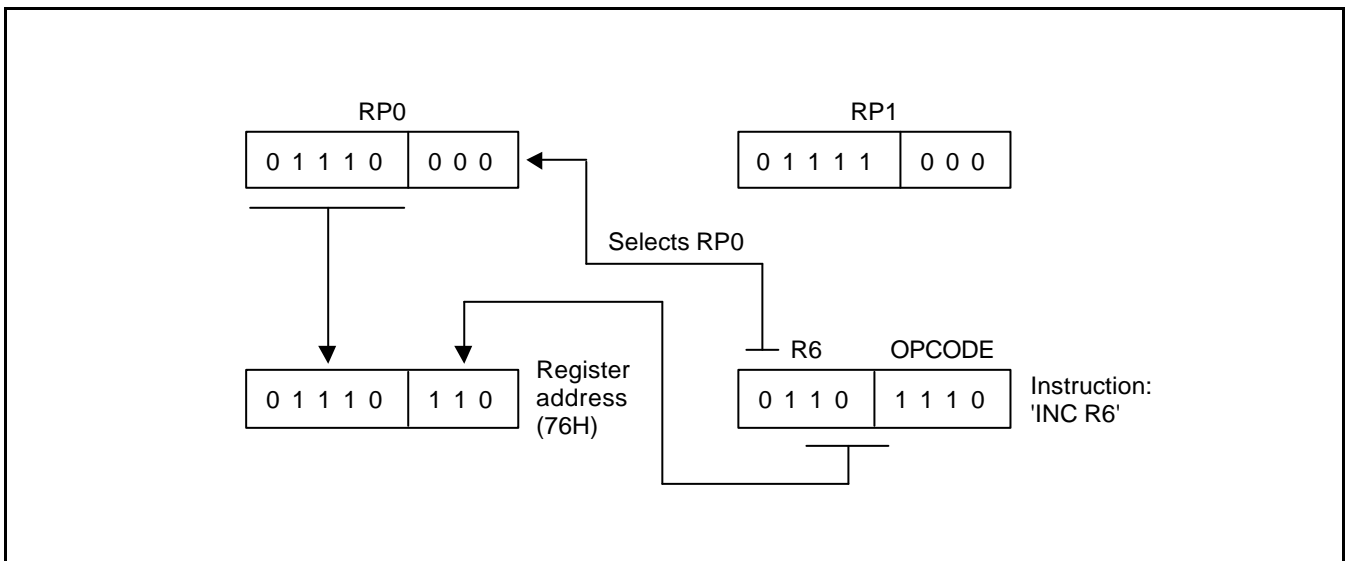


Figure 2-14. 4-Bit Working Register Addressing Example

8-BIT WORKING REGISTER ADDRESSING

You can also use 8-bit working register addressing to access registers in a selected working register area. In order to initiate 8-bit working register addressing, the upper four bits of the instruction address must contain the value 1100B. This 4-bit value (1100B) indicates that the remaining four bits have the same effect as 4-bit working register addressing.

As shown in Figure 2-14, the lower nibble of the 8-bit address is concatenated in much the same way as for 4-bit addressing: bit 3 selects either RP0 or RP1, which then supplies the five high-order bits of the final address, and the three low-order bits of the complete address are provided by the original instruction.

Figure 2-15 shows an example of 8-bit working register addressing: the four high-order bits of the instruction address (1100B) specify 8-bit working register addressing. The fourth bit ("1") selects RP1 and the five high-order bits in RP1 (10100B) become the five high-order bits of the register address. The three low-order bits of the register address (011) are provided by the three low-order bits of the 8-bit instruction address. Together, the five address bits from RP1 and the three address bits from the instruction comprise the complete register address, R163 (10100011B).

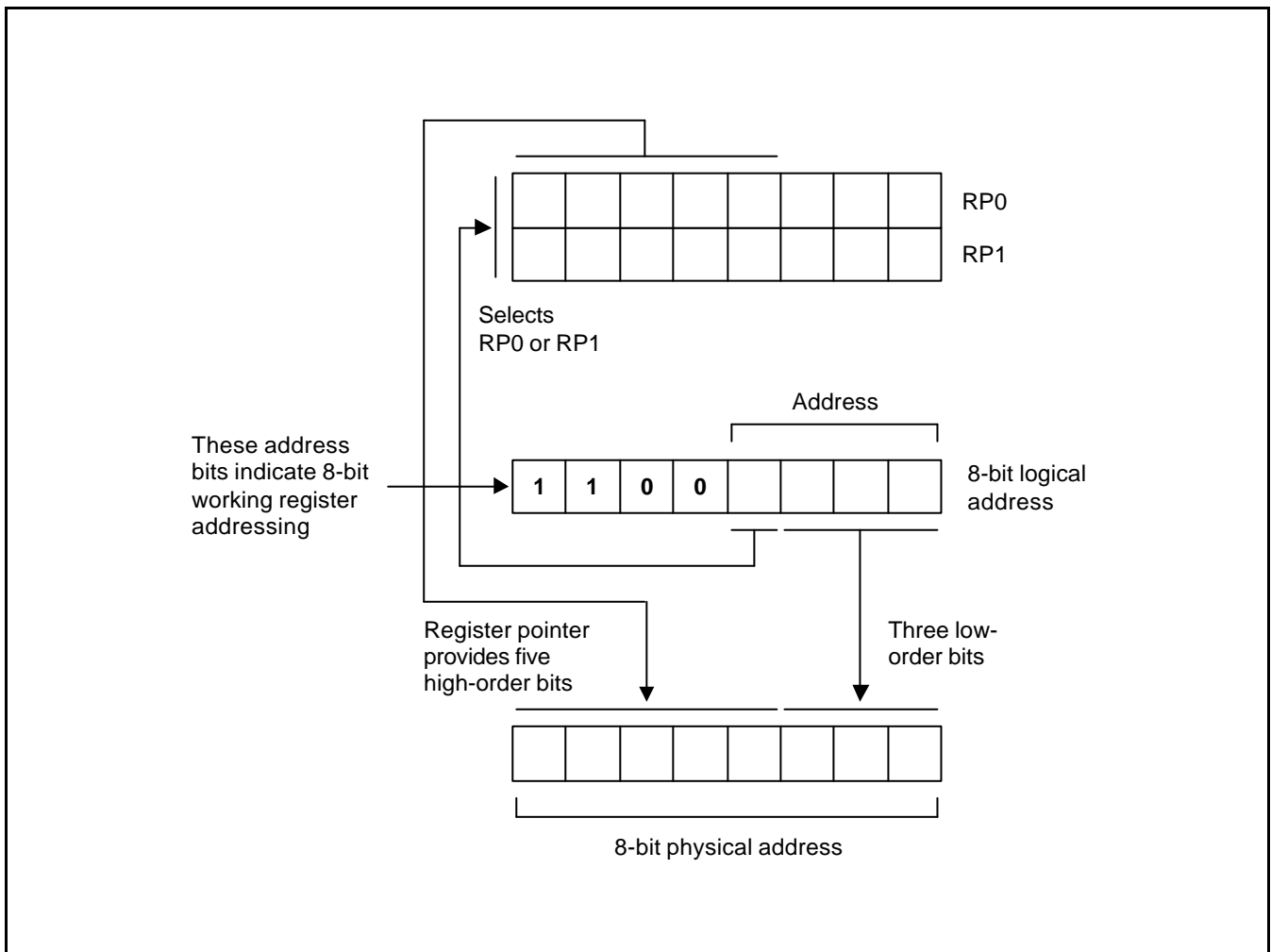


Figure 2-15. 8-Bit Working Register Addressing

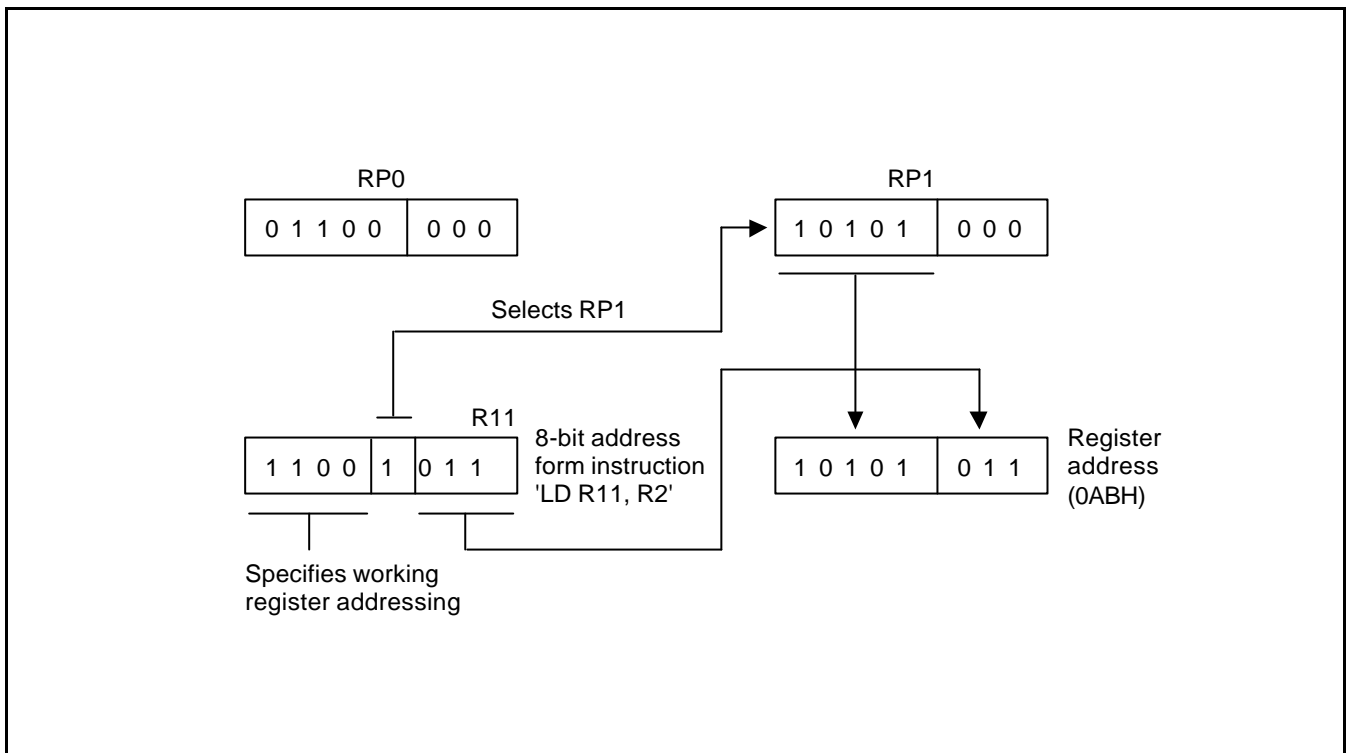


Figure 2-16. 8-Bit Working Register Addressing Example

SYSTEM AND USER STACKS

The S3C8-series microcontrollers use the system stack for subroutine calls and returns, interrupt processing, and data storage. The PUSH and POP instructions support system stack operations. Stack operations in the internal register file and in external data memory are supported by hardware. (The S3C880A/F880A do not support an external memory access.) Bit 1 in the external memory timing register EMT selects an internal or external stack area. The 16-bit stack pointer register (SPH, SPL) is used to access an externally defined system stack. An 8-bit stack pointer (SPL) is sufficient for internal stack addressing.

Stack Operations

Return addresses for procedure calls and interrupts and data are stored on the stack. The contents of the PC are saved to stack by a CALL instruction and restored by an RET instruction. When an interrupt occurs, the contents of the PC and the FLAGS register are pushed to the stack. The IRET instruction then pops these values back to their original locations. The stack address is always decremented *before* a push operation and incremented *after* a pop operation. The stack pointer (SP) always points to the stack frame stored on the top of the stack, as shown in Figure 2-16.

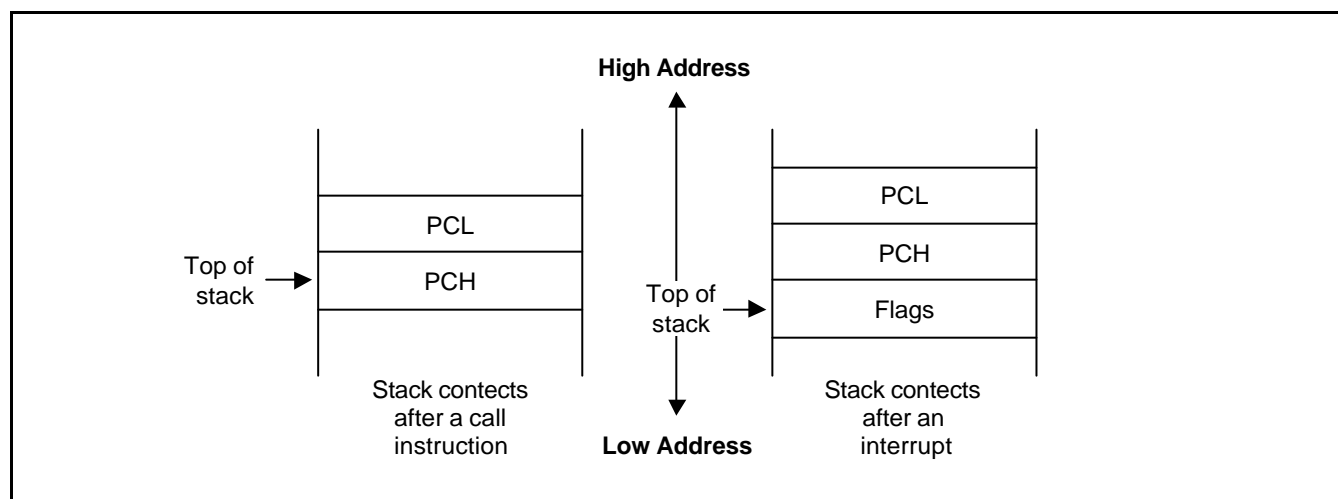


Figure 2-17. Stack Operations

User-Defined Stacks

You can freely define stacks in the internal register file as data storage locations. The instructions, PUSHUI, PUSHUD, POPUI, and POPUD, support user-defined stack operations.

Stack Pointers (SPL, SPH)

The register locations D8H and D9H contain the 16-bit stack pointer (SP) value. The most significant byte of a 16-bit stack address is stored in the SPH register (D8H) and the least significant byte is stored in the SPL register (D9H). Because an external memory interface is not implemented for the S3C880A/F880A microcontrollers, a single 8-bit stack pointer (SPL) is sufficient to address stack locations in the internal register file.

After a reset, the stack pointer value is undetermined. The SPL register must then be initialized to an 8-bit value in the range 00H–FFH, page 0.

You can use the SPH register as a general-purpose data register. Please note that when you do so, data stored in SPH may be overwritten if an overflow or underflow of the SPL register occurs during normal stack operations. To prevent this, you can initialize the SPL value to FFH instead of 00H.

 **PROGRAMMING TIP – Standard Stack Operations Using PUSH and POP**

The following sample code shows how to perform stack operations in the internal register file using PUSH and POP instructions:

```

LD      SPL,#0FFH      ; SPL ← FFH (Normally, the SPL is set to 0FFH by the
•
•
•
PUSH   PP              ; Stack address 0FEH ← PP
PUSH   RP0             ; Stack address 0FDH ← RP0
PUSH   RP1             ; Stack address 0FCH ← RP1
PUSH   R3              ; Stack address 0FBH ← R3
•
•
•
POP    R3              ; R3 ← Stack address 0FBH
POP    RP1             ; RP1 ← Stack address 0FCH
POP    RP0             ; RP0 ← Stack address 0FDH
POP    PP              ; PP ← Stack address 0FEH

```

NOTES

3

ADDRESSING MODES

OVERVIEW

Instructions that are stored in program memory are fetched for execution using the program counter. Instructions indicate the operation to be performed and the data to be operated on. *Addressing mode* is used to determine the location of the data operand. The operands specified in SAM87 instructions may be condition codes, immediate data, or a location in the register file, program memory, or data memory.

The SAM87 instruction set supports seven explicit addressing modes. Not all of these addressing modes are available for each instruction. The addressing modes and their symbols are as follows:

- Register (R)
- Indirect Register (IR)
- Indexed (X)
- Direct Address (DA)
- Indirect Address (IA)
- Relative Address (RA)
- Immediate (IM)

REGISTER ADDRESSING MODE (R)

In Register addressing mode, the operand is the content of a specified register or register pair (see Figure 3-1). Working register addressing differs from Register addressing as it uses a register pointer to specify an 8-byte working register space in the register file and an 8-bit register within that space (see Figure 3-2).

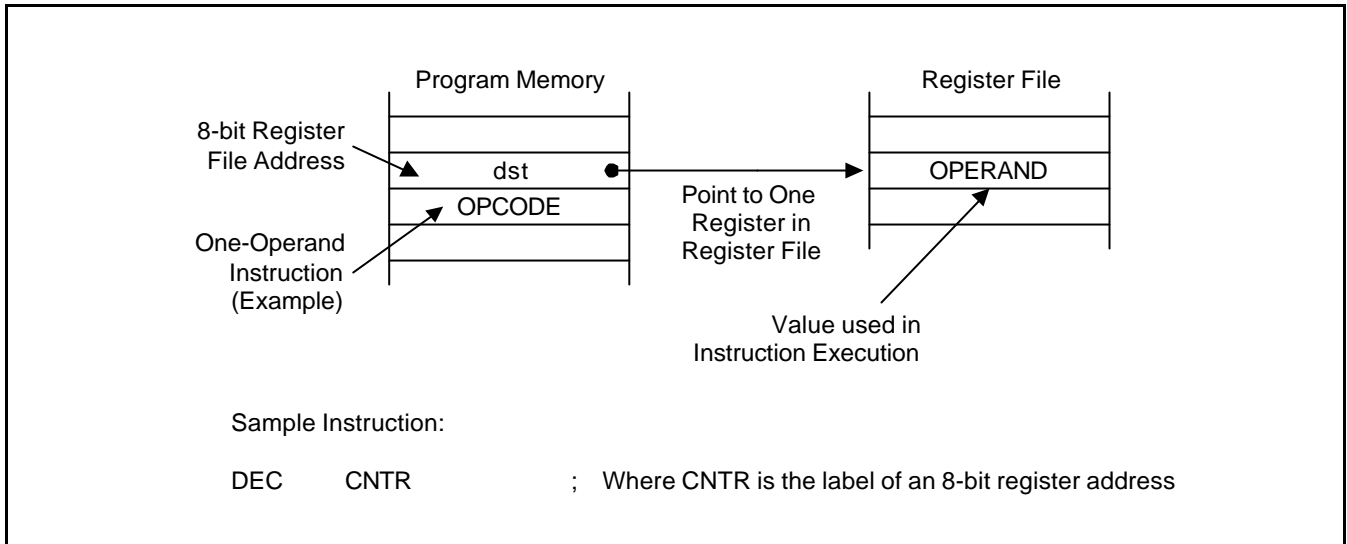


Figure 3-1. Register Addressing

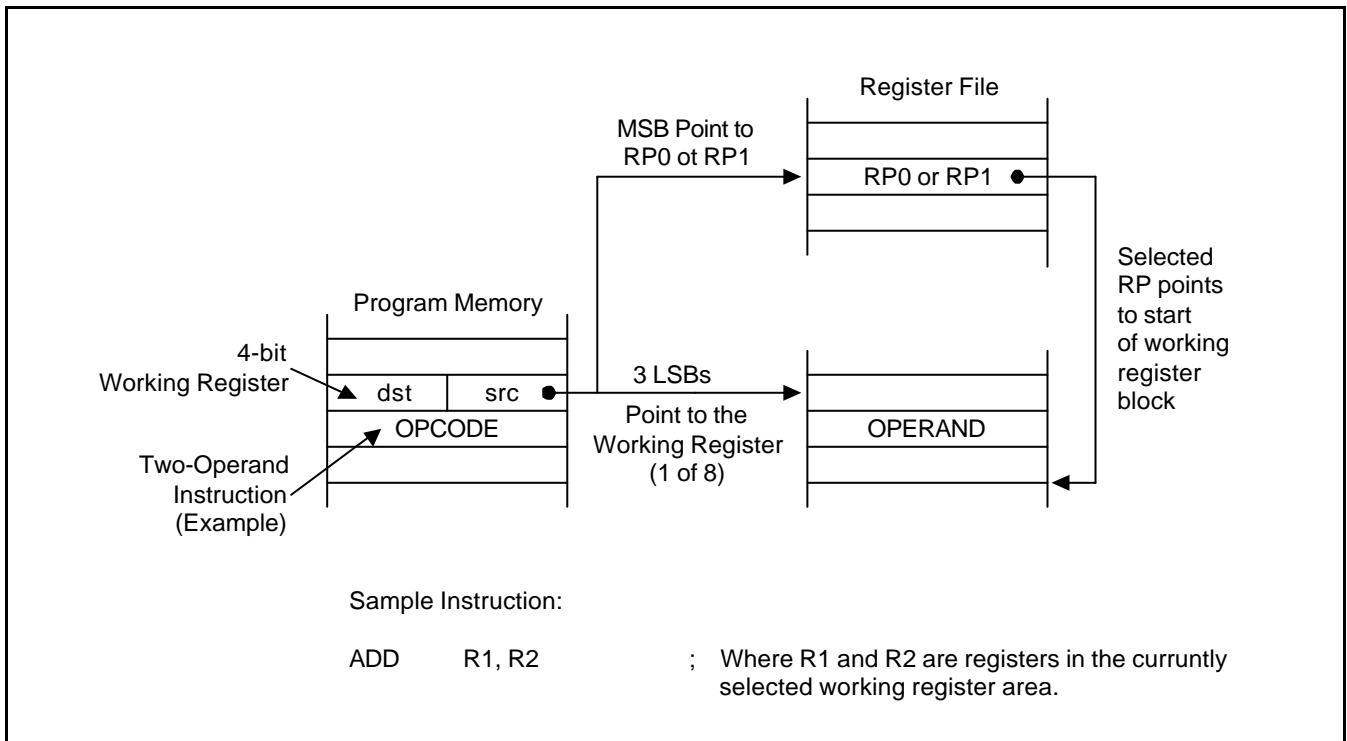


Figure 3-2. Working Register Addressing

INDIRECT REGISTER ADDRESSING MODE (IR)

In Indirect Register (IR) addressing mode, the content of the specified register or register pair is the address of the operand. Depending on the instruction used, the actual address may point to a register in the register file, program memory (ROM), or an external memory space (see Figures 3-3 through 3-6).

You can use any 8-bit register to indirectly address another register. Any 16-bit register pair can be used to indirectly address another memory location. You cannot, however, access the locations C0H–FFH in set 1 using Indirect Register addressing mode.

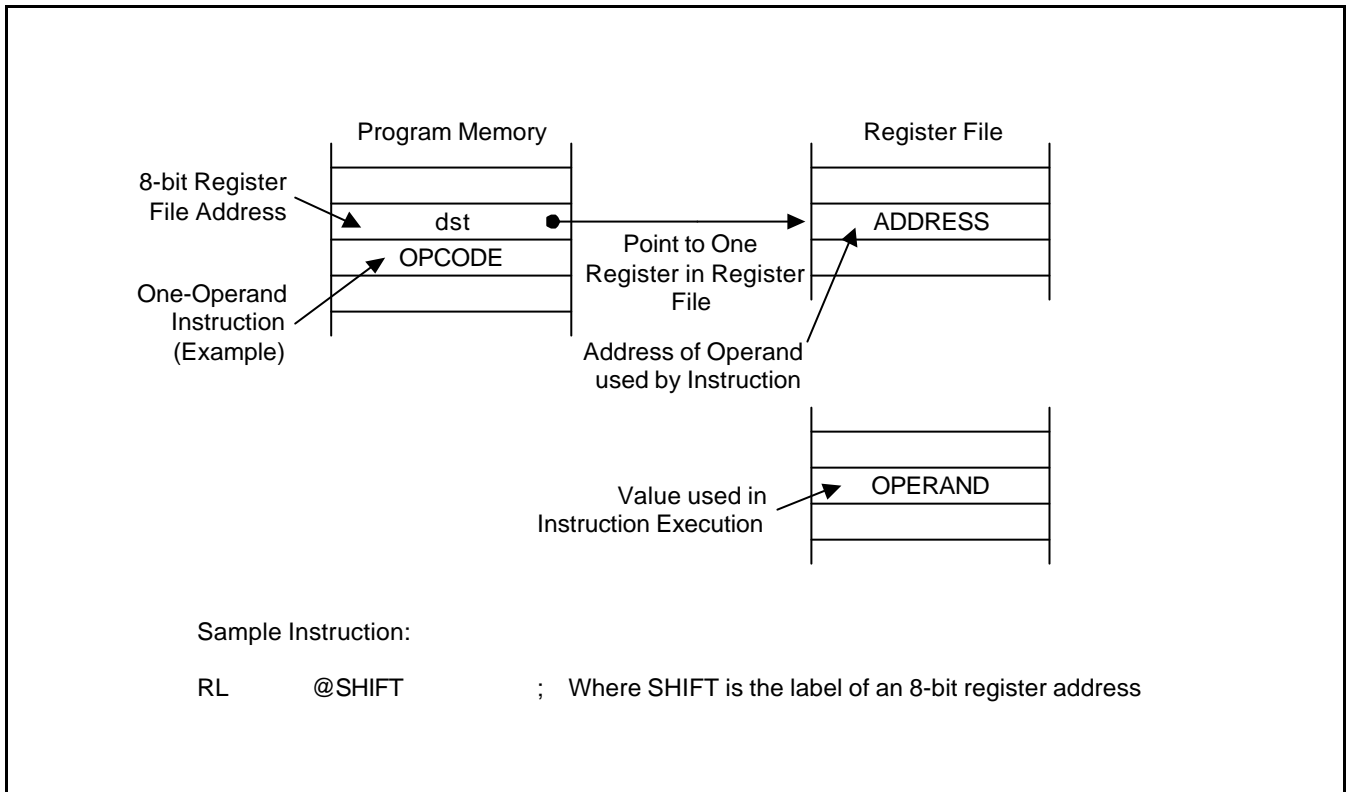


Figure 3-3. Indirect Register Addressing to Register File

INDIRECT REGISTER ADDRESSING MODE (Continued)

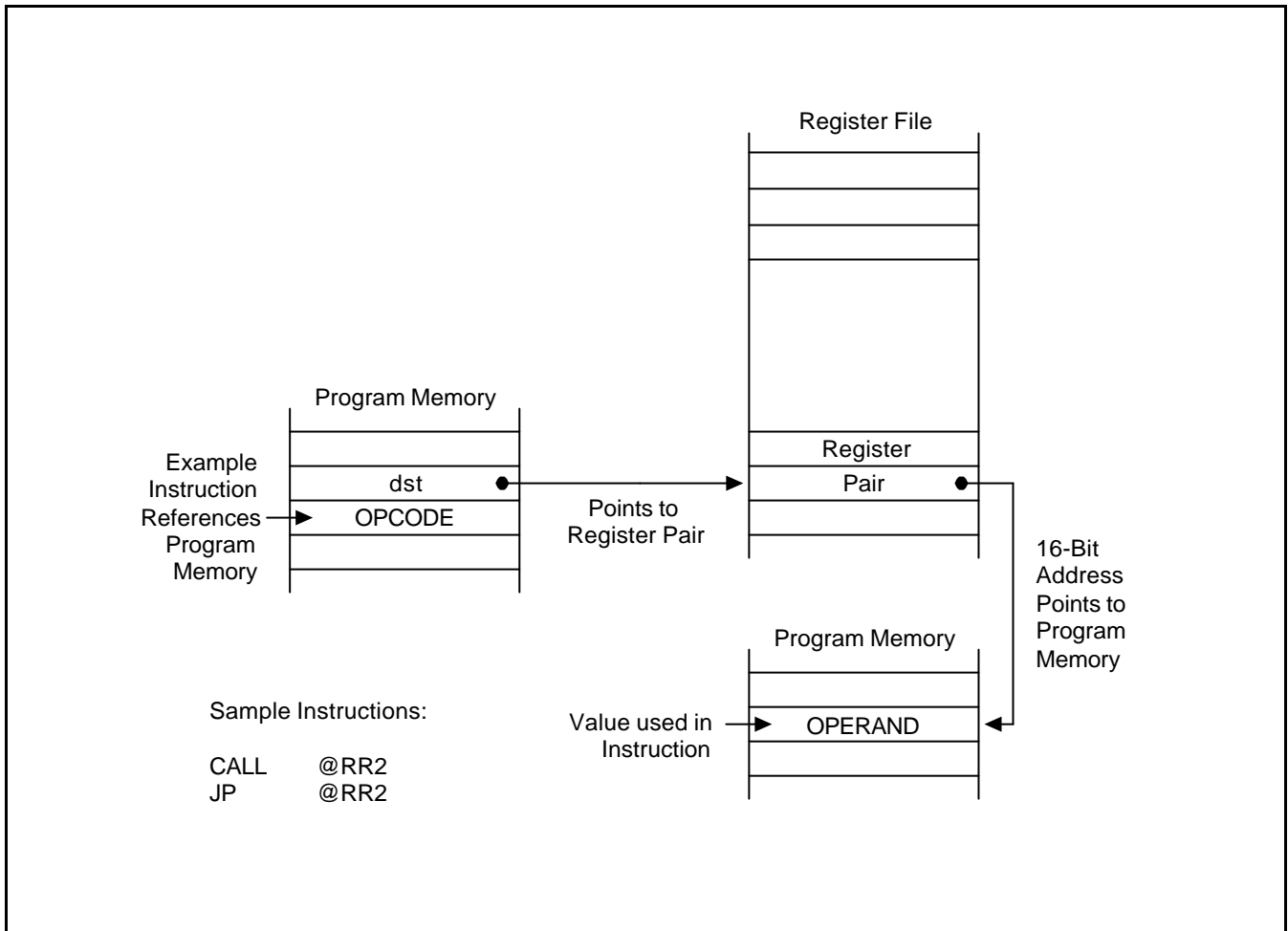


Figure 3-4. Indirect Register Addressing to Program Memory

INDIRECT REGISTER ADDRESSING MODE (Continued)

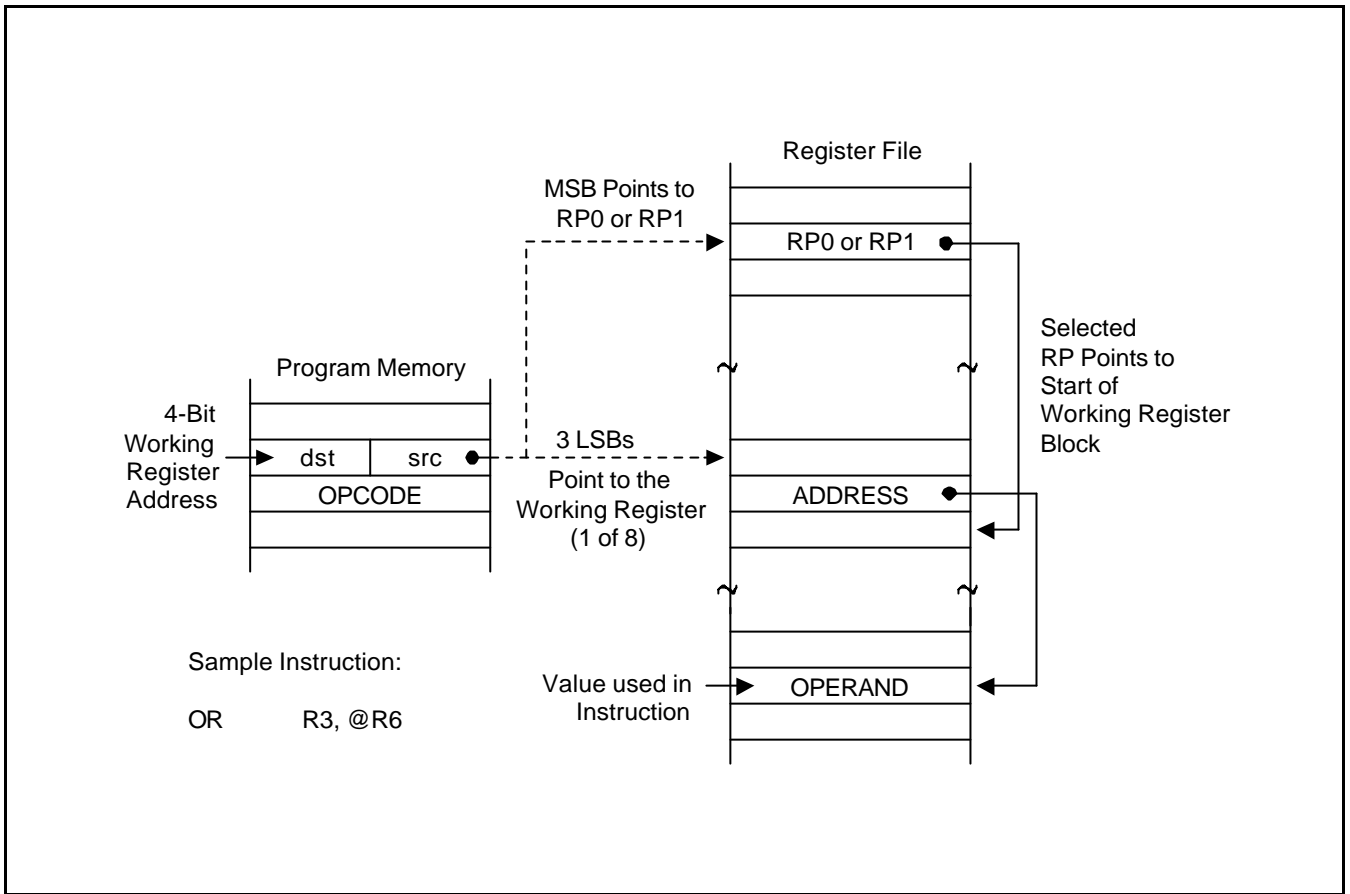


Figure 3-5. Indirect Working Register Addressing to Register File

INDIRECT REGISTER ADDRESSING MODE (Concluded)

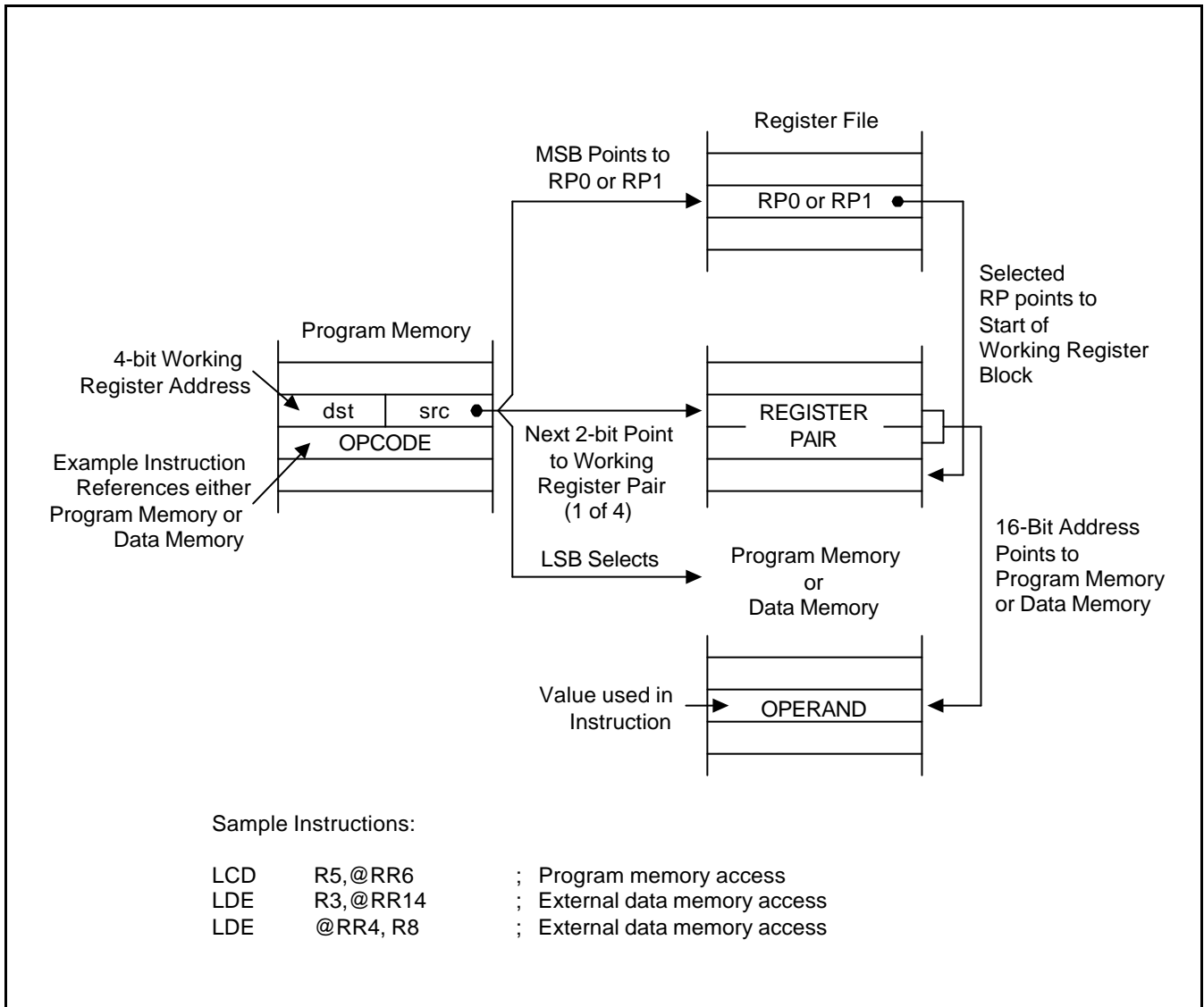


Figure 3-6. Indirect Working Register Addressing to Program or Data Memory

INDEXED ADDRESSING MODE (X)

Indexed (X) addressing mode adds an offset value to a base address during the instruction execution in order to calculate the effective operand address (see Figure 3-7). You can use Indexed addressing mode to access locations in the internal register file or in external memory. You cannot, however, access the locations C0H–FFH in set 1 using Indexed addressing mode.

In short offset Indexed addressing mode, the 8-bit displacement is treated as a signed integer in the range – 128 to + 127. This applies to external memory accesses only (see Figure 3-8).

For register file addressing, an 8-bit base address provided by the instruction is added to an 8-bit offset contained in a working register. For external memory accesses, the base address is stored in the working register pair designated in the instruction. The 8-bit or 16-bit offset given in the instruction is then added to the base address (see Figure 3-9).

The only instruction that supports Indexed addressing mode for the internal register file is the Load instruction (LD). The LDC and LDE instructions support Indexed addressing mode for internal program memory and for external data memory, when implemented.

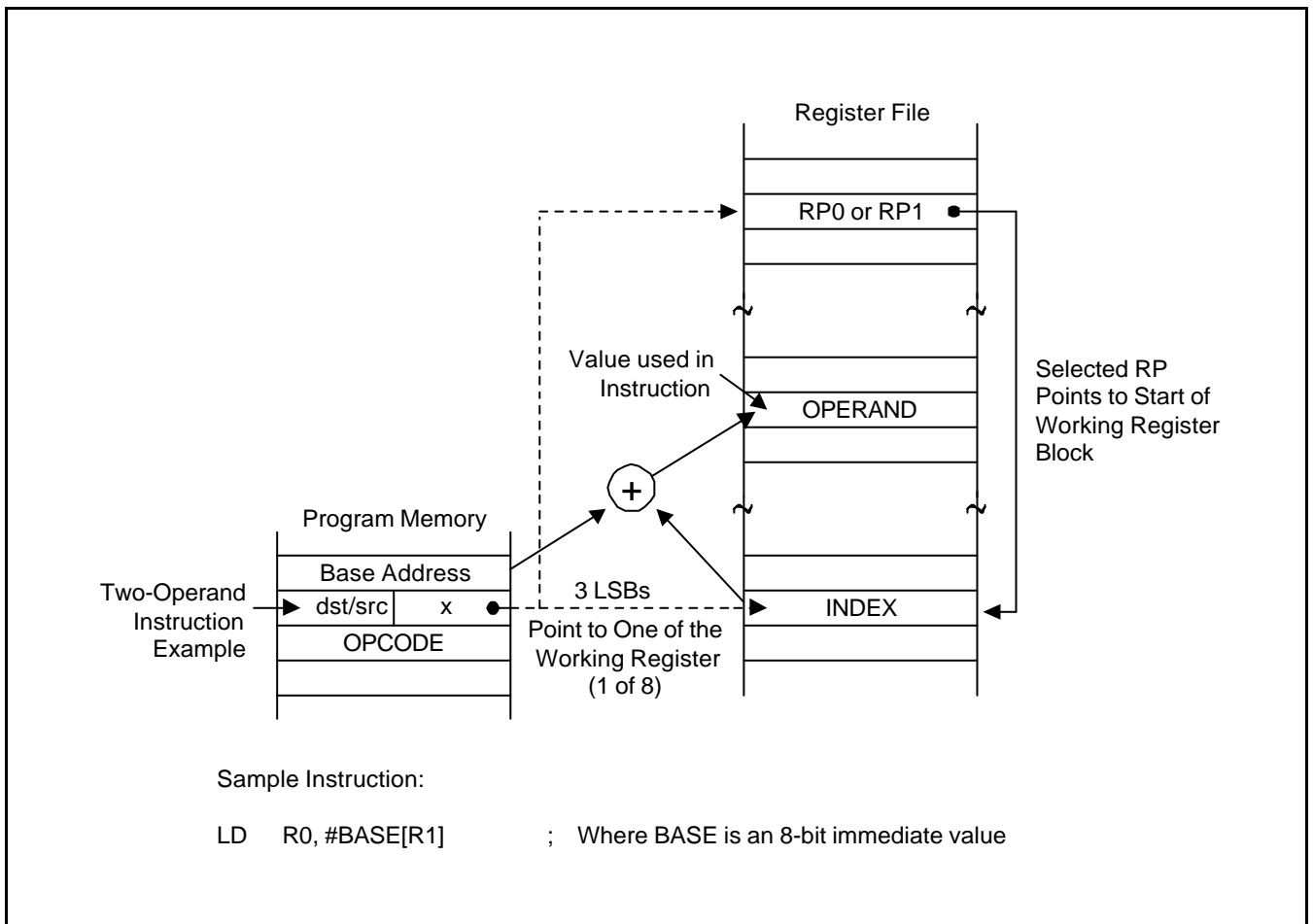


Figure 3-7. Indexed Addressing to Register File

INDEXED ADDRESSING MODE (Continued)

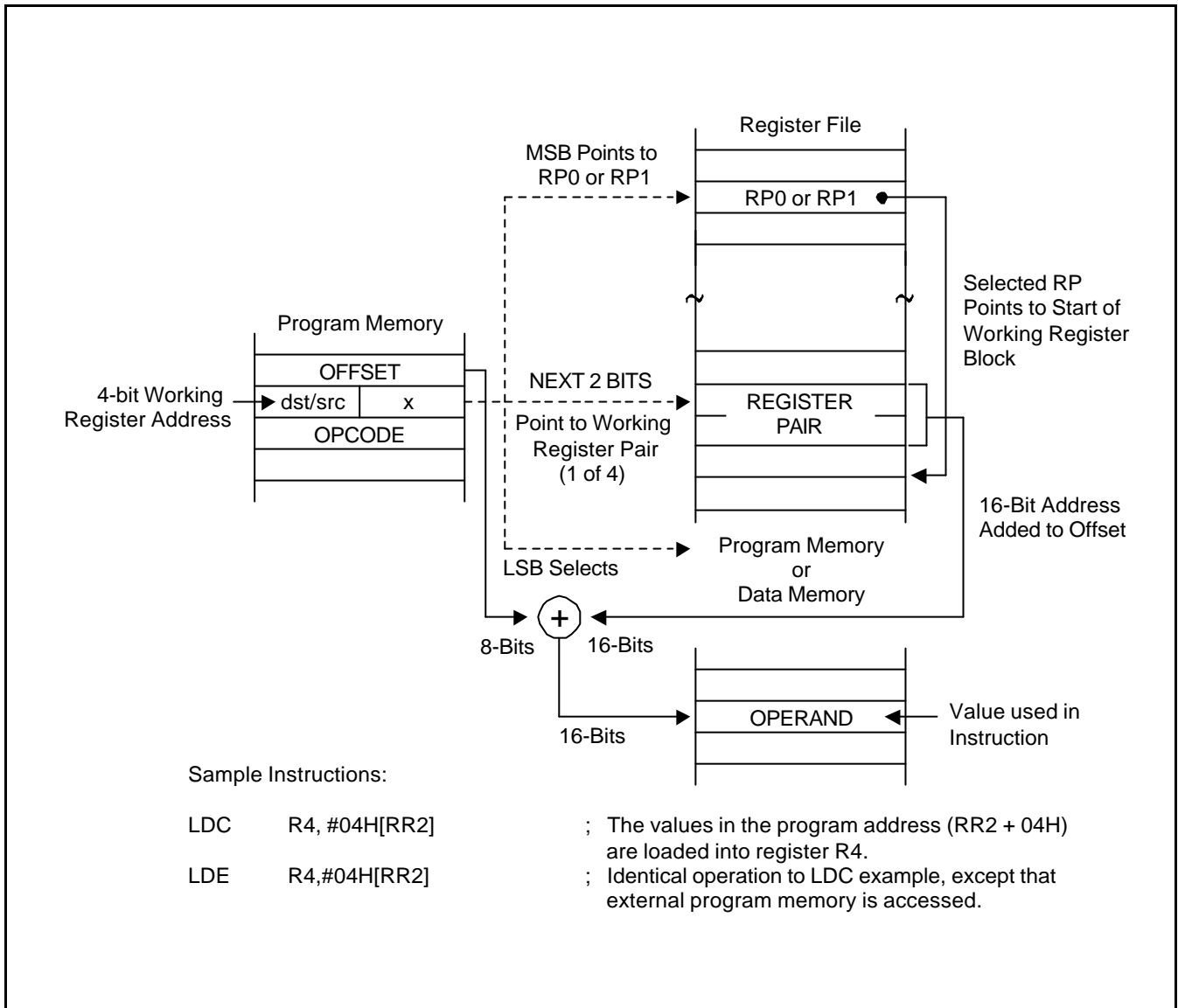


Figure 3-8. Indexed Addressing to Program or Data Memory with Short Offset

INDEXED ADDRESSING MODE (Concluded)

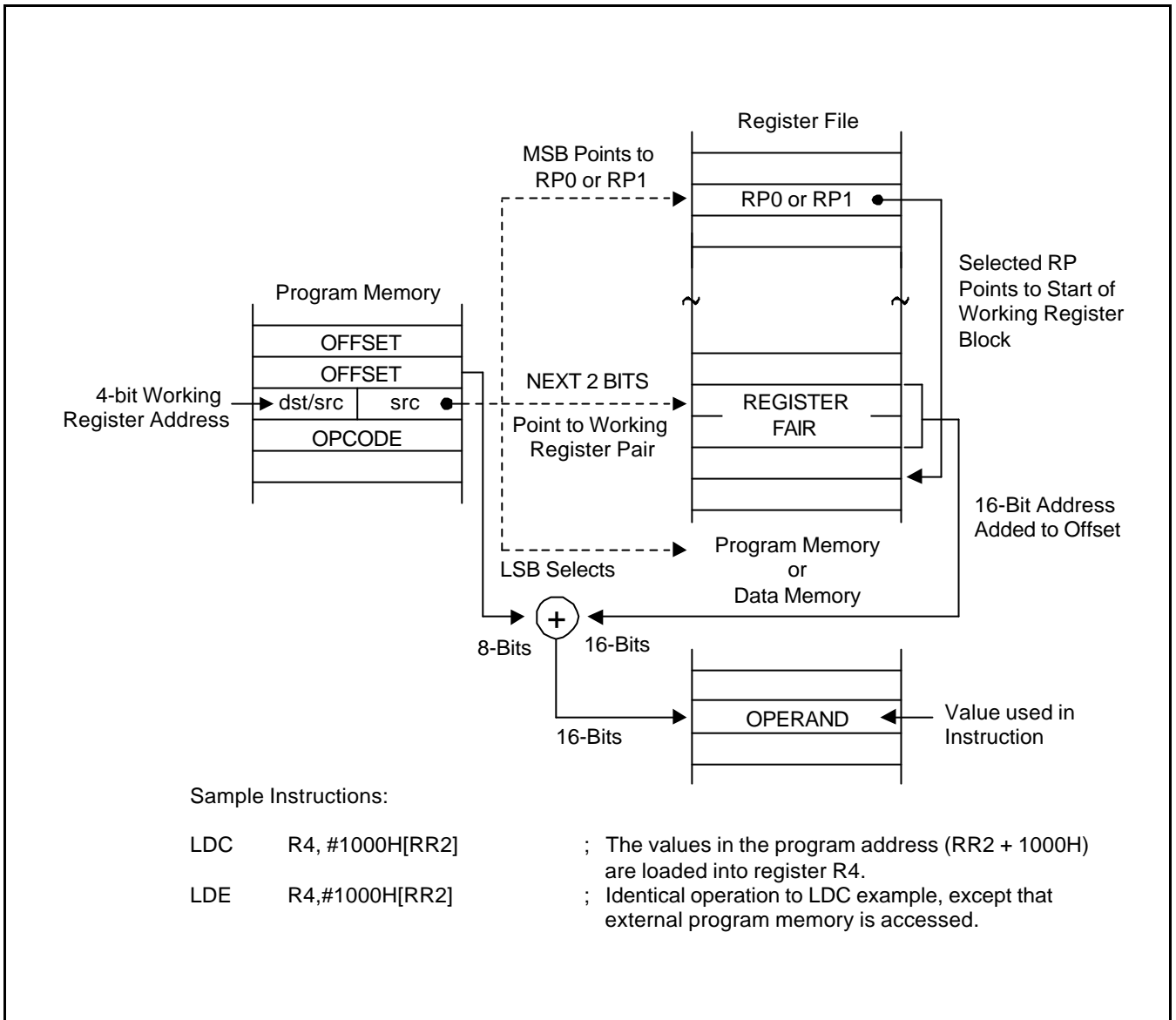


Figure 3-9. Indexed Addressing to Program or Data Memory

DIRECT ADDRESS MODE (DA)

In Direct Address (DA) mode, the instruction provides the operand's 16-bit memory address. Jump (JP) and Call (CALL) instructions use this addressing mode to specify the 16-bit destination address that is loaded into the PC whenever a JP or CALL instruction is executed.

The LDC and LDE instructions can use Direct Address mode to specify the source or the destination address for Load operations to program memory (LDC) or to external data memory (LDE), if implemented.

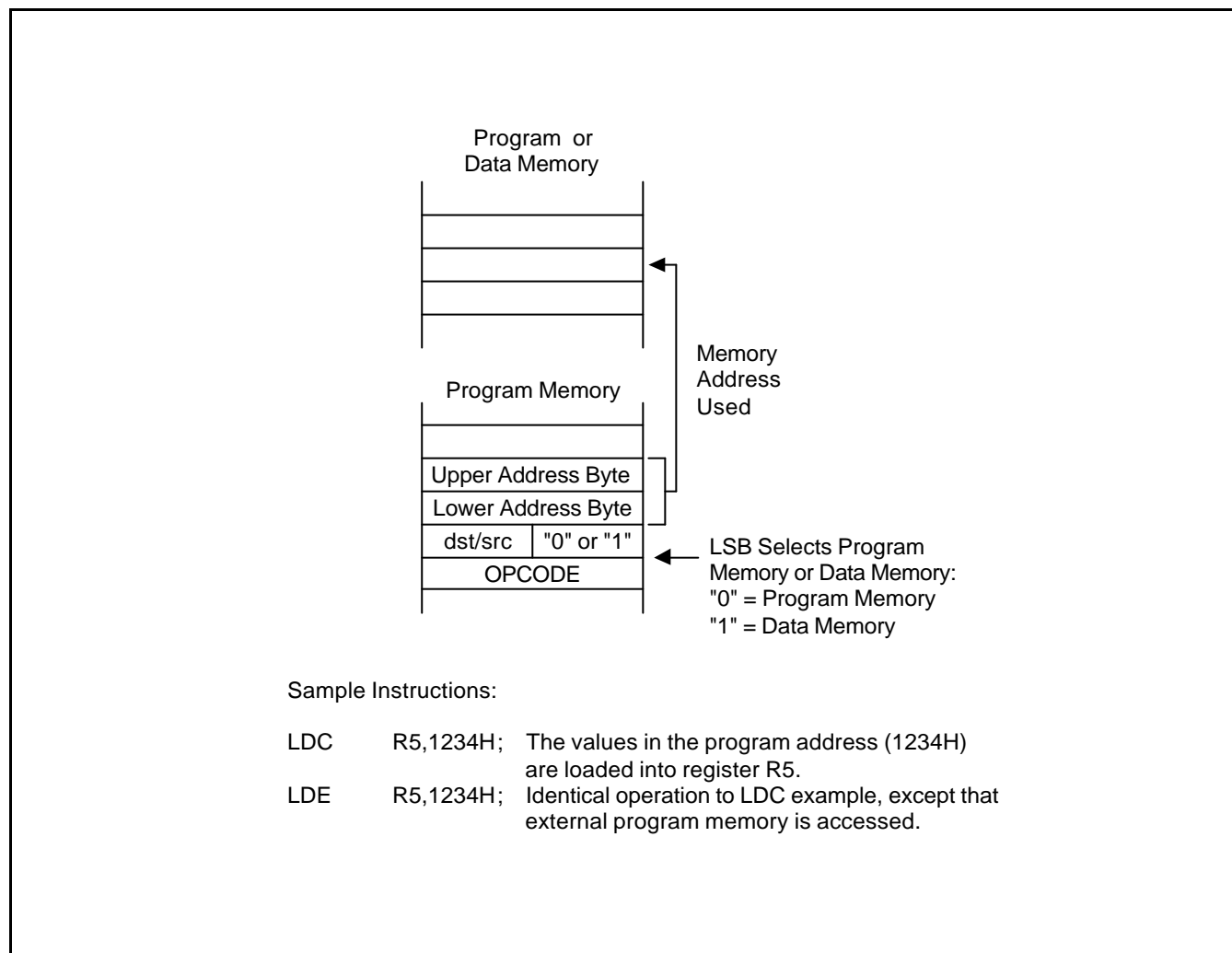


Figure 3-10. Direct Addressing for Load Instructions

DIRECT ADDRESS MODE (Continued)

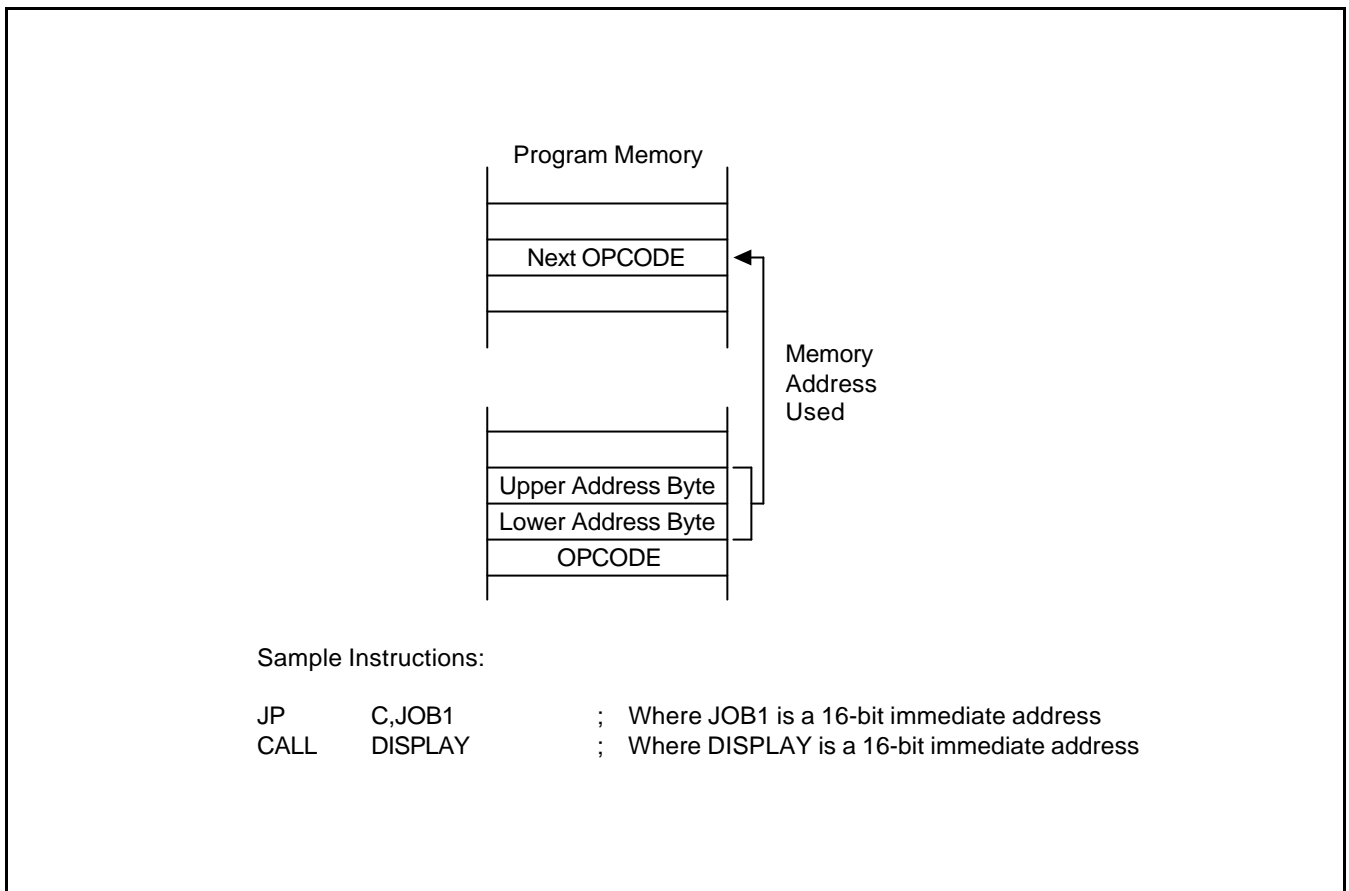


Figure 3-11. Direct Addressing for Call and Jump Instructions

INDIRECT ADDRESS MODE (IA)

In Indirect Address (IA) mode, the instruction specifies an address located in the lower 256 bytes of the program memory. The selected pair of memory locations contains the actual address of the next instruction to be executed. Only the CALL instruction can use Indirect Address mode.

As Indirect Address mode assumes that the operand is located in the lower 256 bytes of the program memory, only an 8-bit address is provided in the instruction; the upper bytes of the destination address are assumed to be all zeros.

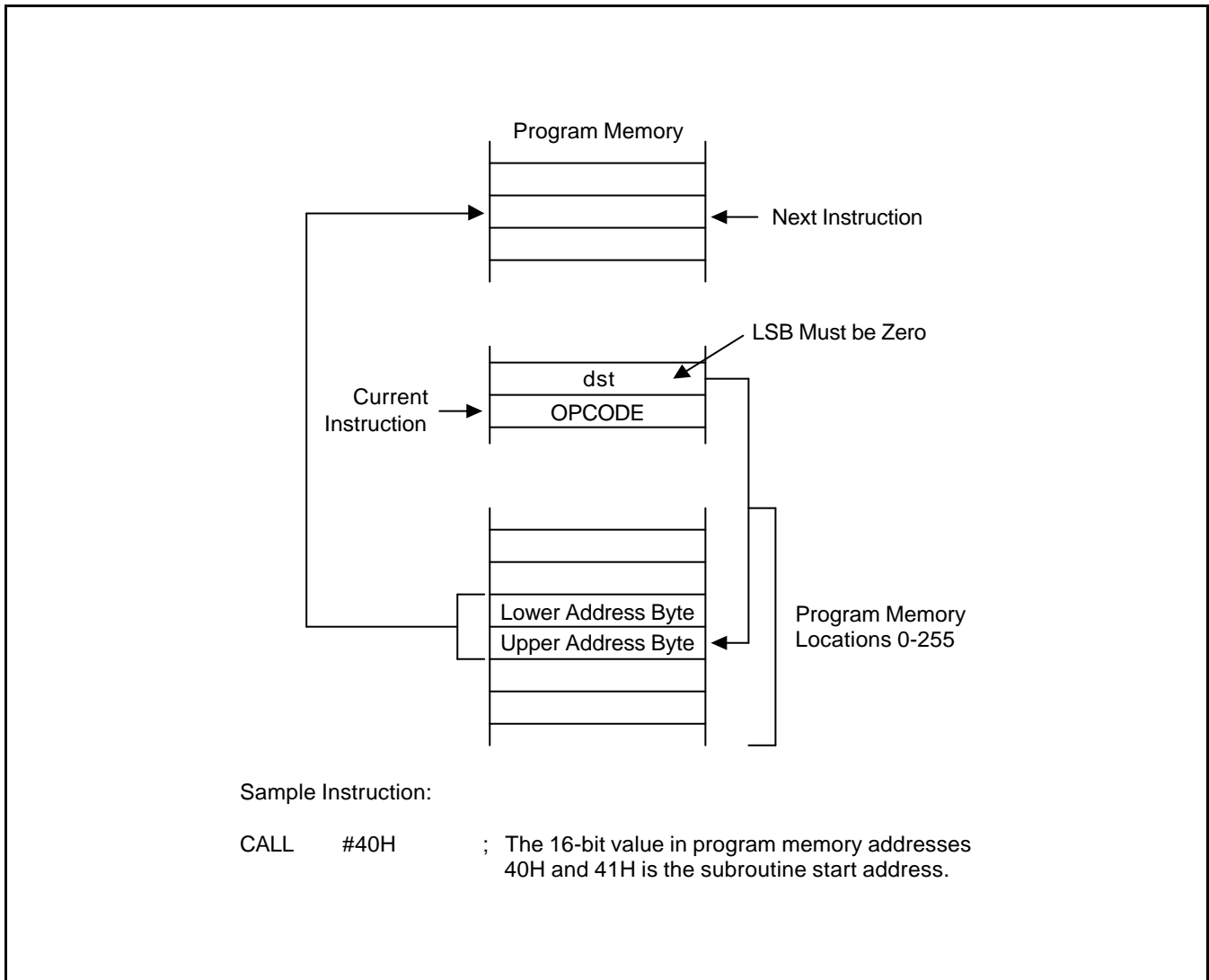


Figure 3-12. Indirect Addressing

RELATIVE ADDRESS MODE (RA)

In Relative Address (RA) mode, a two's-complement signed displacement between - 128 and + 127 is specified in the instruction. The displacement value is then added to the current PC value. The result is the address of the next instruction to be executed. Before this addition occurs, the PC contains the address of the instruction immediately following the current instruction.

Several program control instructions use Relative Address mode to perform conditional jumps. The instructions that support RA addressing are BTJRF, BTJRT, DJNZ, CPIJE, CPIJNE, and JR.

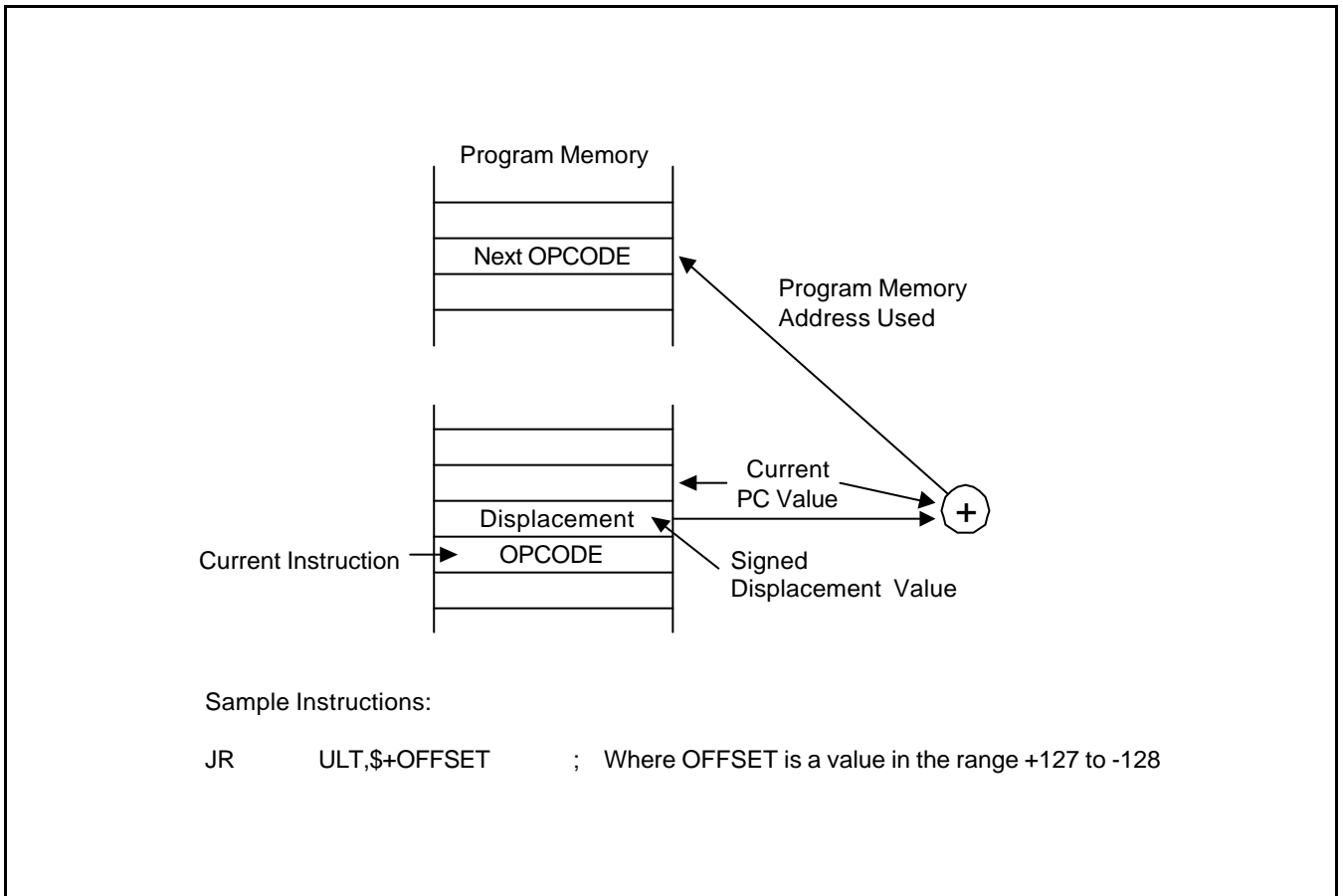


Figure 3-13. Relative Addressing

IMMEDIATE MODE (IM)

In Immediate (IM) addressing mode, the operand value used in the instruction is the value supplied in the operand field itself. The operand may be one byte or one word in length, depending on the instruction used. Immediate addressing mode is useful for loading constant values into registers.

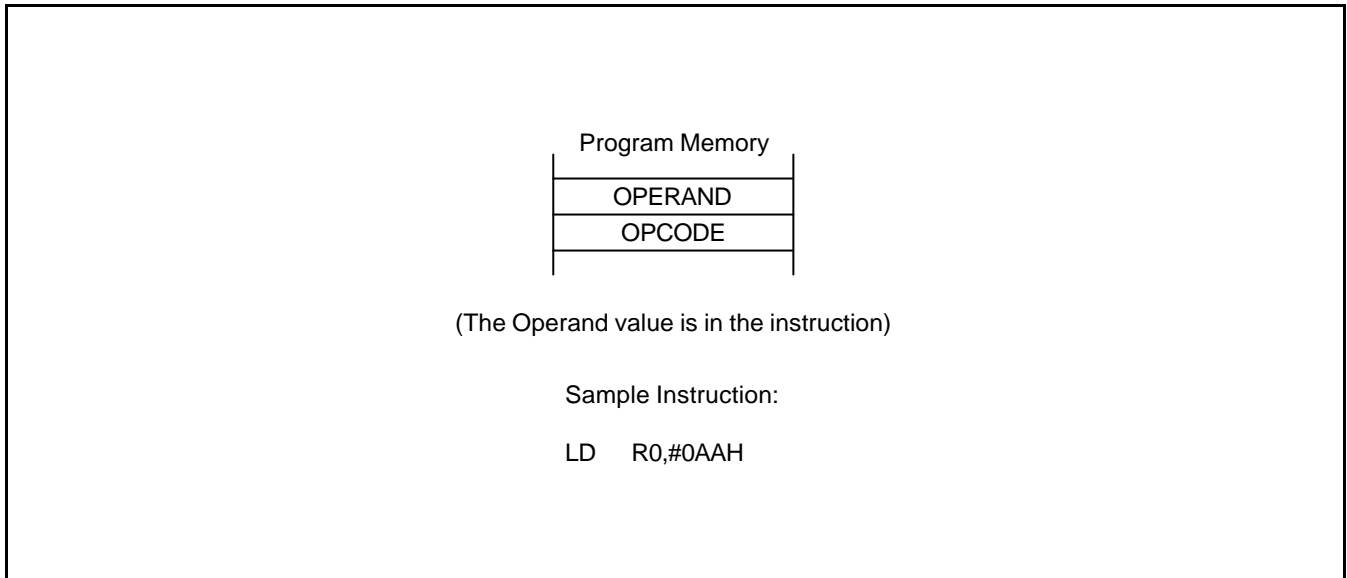


Figure 3-14. Immediate Addressing

4 CONTROL REGISTERS

OVERVIEW

In this chapter, detailed descriptions of the S3C880A/F880A control registers are presented in an easy-to-read format. These descriptions will help familiarize you with the mapped locations in the register file. You can also use them as a quick-reference source when writing application programs.

System and peripheral registers are summarized in Tables 4-1, 4-2, and 4-3. Figure 4-1 illustrates the important features of the standard register description format.

Control register descriptions are arranged in alphabetical order according to register mnemonic. More information about control registers is presented in the context of the various peripheral hardware descriptions in Part II of this manual.

Table 4-1. Set 1 Registers

Register Name	Mnemonic	Decimal	Hex	R/W
Timer 0 counter	T0CNT	208	D0H	R
Timer 0 data register	T0DATA	209	D1H	R/W
Timer 0 control register	T0CON	210	D2H	R/W
Basic timer control register	BTCON	211	D3H	R/W
Clock control register	CLKCON	212	D4H	R/W
System flags register	FLAGS	213	D5H	R/W
Register pointer 0	RP0	214	D6H	R/W
Register pointer 1	RP1	215	D7H	R/W
Stack pointer (high byte)	SPH	216	D8H	R/W
Stack pointer (low byte)	SPL	217	D9H	R/W
Instruction pointer (high byte)	IPH	218	DAH	R/W
Instruction pointer (low byte)	IPL	219	DBH	R/W
Interrupt request register	IRQ	220	DCH	R
Interrupt mask register	IMR	221	DDH	R/W
System mode register	SYM	222	DEH	R/W
Register page pointer	PP	223	DFH	R/W

Table 4-2. Set 1, Bank 0 Registers

Register Name	Mnemonic	Decimal	Hex	R/W
Port 0 data register	P0	224	E0H	R/W
Port 1 data register	P1	225	E1H	R/W
Port 2 data register	P2	226	E2H	R/W
Port 3 data register	P3	227	E3H	R/W
Port 0 control register (high byte)	P0CONH	228	E4H	R/W
Port 0 control register (low byte)	P0CONL	229	E5H	R/W
Port 1 control register (high byte)	P1CONH	230	E6H	R/W
Port 1 control register (low byte)	P1CONL	231	E7H	R/W
Port 2 control register (high byte)	P2CONH	232	E8H	R/W
Port 2 control register (low byte)	P2CONL	233	E9H	R/W
Location EAH in set 1, bank 0, are not mapped.				
Port 3 control register (low byte)	P3CONL	235	EBH	R/W
Locations ECH - EEH in set 1, bank 0, are not mapped.				
PLL control register (note)	PLLCON	236	EFH	R/W

NOTE: PLL control register, PLLCON, is a system register for factory test. So user should not access this register.

Table 4-2. Set 1, Bank 0 Registers (Continued)

Register Name	Mnemonic	Decimal	Hex	R/W
Timer A data register	TADATA	240	F0H	R/W
Location F1H in set 1, bank 0, are not mapped.				
STOP control register	STCON	238	F3H	R/W
Timer A control register	TACON	242	F2H	R/W
PWM0 data register (main byte)	PWM0	244	F4H	R/W
PWM0 data register (extension byte)	PWM0EX	245	F5H	R/W
PWM1 data register (main byte)	PWM1	246	F6H	R/W
PWM1 data register (extension byte)	PWM1EX	247	F7H	R/W
PWM control register	PWMCON	248	F8H	R/W
Capture A data register	CAPA	249	F9H	R
A/D converter control register	ADCON	250	FAH	R/W (2)
A/D conversion data register	ADDATA	251	FBH	R
Test control register	TSTC	252	FCH	R/W (1)
Basic timer counter	BTCNT	253	FDH	R
External memory timing register	EMT	254	FEH	R/W
Interrupt priority register	IPR	255	FFH	R/W

NOTE: Test control register, TSTC, is a system register for factory test. So user should not access this register.

Table 4-3. Set 1, Bank 1 Registers

Register Name	Mnemonic	Decimal	Hex	R/W
OSD fringe/border control register 1	OSDFRG1	224	E0H	R/W
OSD fringe/border control register 2	OSDFRG2	225	E1H	R/W
OSD smooth control register 1	OSDSMH1	226	E2H	R/W
OSD smooth control register 2	OSDSMH2	227	E3H	R/W
OSD space color control register	OSDCOL	236	E4H	R/W
OSD field control register	OSDFLD	237	E5H	R/W
OSD palette color mode R 1	OSDPLTR1	230	E6H	R/W
OSD palette color mode R 2	OSDPLTR2	231	E7H	R/W
OSD palette color mode G 1	OSDPLTG1	232	E8H	R/W
OSD palette color mode G 2	OSDPLTG2	233	E9H	R/W
OSD palette color mode B 1	OSDPLTB1	234	EAH	R/W
OSD palette color mode B 2	OSDPLTB2	235	EBH	R/W
Locations ECH–EFH in set 1, bank 1, are not mapped.				
OSD character size control register	CHACON	240	F0H	R/W
OSD fade control register	FADECON	241	F1H	R/W
OSD row position control register	ROWCON	242	F2H	R/W
OSD column position control register	CLMCON	243	F3H	R/W
OSD background color control register	COLCON	244	F4H	R/W
On-screen display control register	DSPCON	245	F5H	R/W
Halftone signal control register	HTCON	246	F6H	R/W
V-SYNC blank control register	VSBCON	251	F7H	R/W
PWM2 Data register	PWM2	247	F8H	R/W
PWM3 Data register	PWM3	248	F9H	R/W
PWM4 Data register	PWM4	249	FAH	R/W
PWM5 Data register	PWM5	250	FBH	R/W
OSD Color Buffer	COLBUF	252	FCH	R/W
Locations FDH–FFH in set 1, bank 1, are not mapped.				

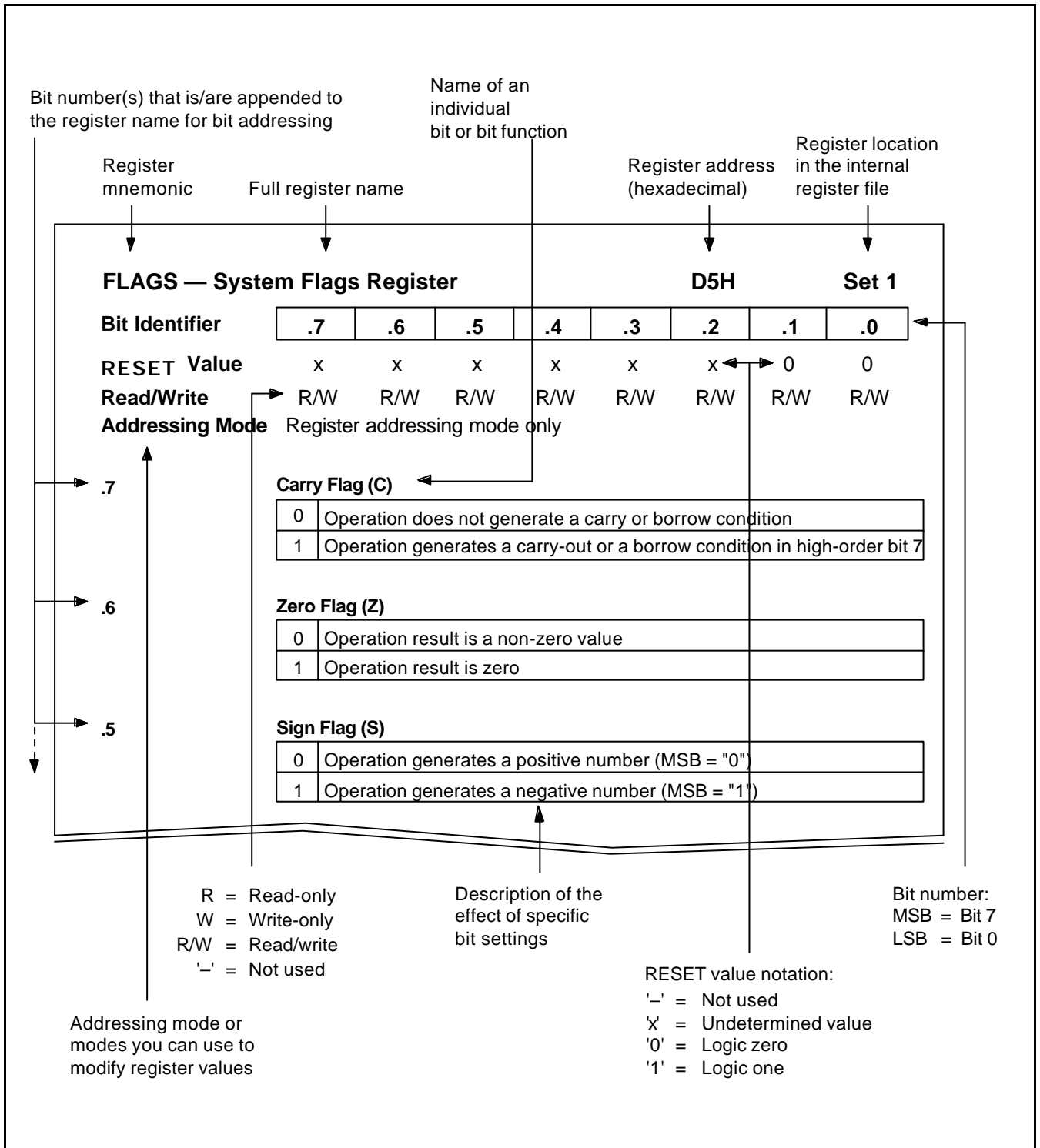


Figure 4-1. Register Description Format



ADCON — A/D Converter Control Register

FAH

Set 1, Bank 0

Bit Identifier	.7	.6	.5	.4	.3	.2	.1	.0
nRESET Value	–	–	0	0	x	0	0	0
Read/Write	–	–	R/W	R/W	R	R/W	R/W	R/W
Addressing Mode	Register addressing mode only							

.7–.6

Not used for the S3C880A/F880A

.5–.4

A/D Converter Input Pin Selection Bits

0	0	ADC0 (P3.0)
0	1	ADC1 (P3.1)
1	0	ADC2 (P0.6)
1	1	ADC3 (P0.7)

.3

End-of-Conversion Status Bit (Read Only)

0	A/D conversion is in progress
1	A/D conversion complete

.2 and .1

Clock Source Selection Bits

0	0	fosc/16 (fosc < 8 MHz)
0	1	fosc/8 (fosc < 8 MHz)
1	0	fosc/14(fosc < 8 MHz)
1	1	fosc/2 (fosc < 8 MHz)

.0

Conversion Start Bit

0	No meaning
0	A/D conversion start

BTCON — Basic Timer Control Register

D3H

Set 1

Bit Identifier	.7	.6	.5	.4	.3	.2	.1	.0
nRESET Value	0	0	0	0	0	0	0	0
Read/Write	R/W	R/W	R/W	R/W	R/W	R/W	R/W	R/W
Addressing Mode	Register addressing mode only							

.7-.4

Watchdog Timer Function Disable Code (for Reset)

1	0	1	0	Disable watchdog timer function
Others				Enable watchdog timer function

.3 and .2

Basic Timer Input Clock Selection Bits

0	0	$f_{OSC}/4096$
0	1	$f_{OSC}/1024$
1	0	$f_{OSC}/128$
1	1	Invalid selection

.1

Basic Timer Counter Clear Bit (note)

0	No effect
1	Clear the basic timer counter value

.0

Clock Divider Clear Bit for Basic Timer and Timer 0 (note)

0	No effect
1	Clear both dividers

NOTE: When you write a "1" to bit 0 or bit 1, the corresponding divider or counter value is cleared to '00H'. The corresponding BTCON bit is then automatically reset by hardware to "0".

CHACON — OSD Character Size Control Register

F0H

Set 1, Bank 1

Bit Identifier	.7	.6	.5	.4	.3	.2	.1	.0
nRESET Value	0	0	0	0	0	0	0	0
Read/Write	R/W	R/W	R/W	R/W	R/W	R/W	R/W	R/W
Addressing Mode	Register addressing mode only							

.7 and .6

Vertical Character Size Selection Bits

0	0	Select 'x1' vertical character size
0	1	Select 'x2' vertical character size
1	0	Select 'x3' vertical character size
1	1	Select 'x4' vertical character size

.5 and .4

Horizontal Character Size Selection Bits

0	0	Select 'x1' horizontal character size
0	1	Select 'x2' horizontal character size
1	0	Select 'x3' horizontal character size
1	1	Select 'x4' horizontal character size

.3-.0

Fade Row Address Selection for Rows 0–11 in On-Screen Display

0	0	0	0	Row 0 selected
0	0	0	1	Row 1 selected
0	0	1	0	Row 2 selected
0	0	1	1	Row 3 selected
0	1	0	0	Row 4 selected
0	1	0	1	Row 5 selected
0	1	1	0	Row 6 selected
0	1	1	1	Row 7 selected
1	0	0	0	Row 8 selected
1	0	0	1	Row 9 selected
1	0	1	0	Row 10 selected
1	0	1	1	Row 11 selected
Others				Invalid selection

CLKCON — System Clock Control Register

D4H

Set 1

Bit Identifier	.7	.6	.5	.4	.3	.2	.1	.0
nRESET Value	0	0	0	0	0	0	0	0
Read/Write	R/W	R/W	R/W	R/W	R/W	R/W	R/W	R/W
Addressing Mode	Register addressing mode only							

.7

Oscillator IRQ Wake-up Function Enable Bit

0	Enable IRQ for main system oscillator wake-up in power-down mode
1	Disable IRQ for main system oscillator wake-up in power-down mode

.6 and .5

Main Oscillator Stop Control Bits

0	0	No effect
0	1	No effect
1	0	Stop main oscillator
1	1	No effect

.4 and .3

CPU Clock (System Clock) Selection Bits ⁽¹⁾

0	0	Divide by 16 ($f_{OSC}/16$)
0	1	Divide by 8 ($f_{OSC}/8$)
1	0	Divide by 2 ($f_{OSC}/2$)
1	1	Non-divided clock (f_{OSC})

.2-.0

Subsystem Clock Selection Bits ⁽²⁾

1	0	1	Invalid selection for S3C880A/F880A
Others			Select main system clock (MCLK)

NOTES:

1. After a reset, the slowest clock (divide by 16) is selected as the system clock. To select faster clock speeds, load the appropriate values to CLKCON.3 and CLKCON.4.
2. These selection bits are required only for systems that have a main clock and a subsystem clock. The S3C880A/F880A microcontrollers have only a main oscillator (and an L-C oscillator for the OSD module). For this reason, the setting '101B' is invalid.

CLMCON — OSD Column Control Register

F3H

Set 1, Bank 1

Bit Identifier	.7	.6	.5	.4	.3	.2	.1	.0
nRESET Value	0	0	0	0	0	0	0	0
Read/Write	R/W	R/W	R/W	R/W	R/W	R/W	R/W	R/W
Addressing Mode	Register addressing mode only							

.7–.3

Left Margin Display Position Control Bits (16 + 4 x LMG value of 0–31 dots)

0	0	0	0	0	Left margin = 16 dot clocks
0	0	0	0	1	Left margin = 16 + 4 × 1 dot clock
...					...
1	1	1	1	1	Left margin = 16 + 4 × 31 dot clocks

.2–.0

Inter-Column Spacing Control Selection (0–7 dots)

0	0	0	No inter-column spacing
0	0	1	Inter-column spacing = 1 dot
...			...
1	1	1	Inter-column spacing = 7 dots

NOTE: To set left margin and inter-column spacing, separate decimal values must be calculated, converted to their binary equivalents, and then written to the CLMCON register.

COLBUF — OSD Character Color Buffer

FCH

Set 1, Bank 1

Bit Identifier	.7	.6	.5	.4	.3	.2	.1	.0
nRESET Value	–	–	–	X	X	X	X	X
Read/Write	–	–	–	R/W	R/W	R/W	R/W	R/W
Addressing Mode	Register addressing mode only							

.7–.6

Not used for the S3C880A/F880A.

.5 **Video RAM Bit-9 Enable Bit**

0	Disable VRAM bit-9
1	Enable VAM bit-9

.4 **Video RAM Bit-8 Enable Bit**

0	Disable VRAM bit-8
1	Enable VRAM bit-8

.3 **H/T and BGRND Enable Bit**

0	Disable H/T and BRGND
1	Enable H/T and BRGND

.2–.0 **Character Color Selection Bits**

.2	.1	.0	OSDCOL.0 = 0	OSDCOL.0 = 1
0	0	0	Black	Color mode 0
0	0	1	Blue	Color mode 1
0	1	0	Green	Color mode 2
0	1	1	Cyan	Color mode 3
1	0	0	Red	Color mode 4
1	0	1	Magenta	Color mode 5
1	1	0	Yellow	Color mode 6
1	1	1	White	Color mode 7

COLCON — OSD Background Color Control Register

F4H

Set 1, Bank 1

Bit Identifier	.7	.6	.5	.4	.3	.2	.1	.0
nRESET Value	0	0	0	0	0	0	0	0
Read/Write	R/W	R/W	R/W	R/W	R/W	R/W	R/W	R/W
Addressing Mode	Register addressing mode only							

.7 Frame Background Color Enable Bit

0	Disable frame background color (no background color is displayed)
1	Enable frame background color

.6-.4 Frame Background Color Selection Bits (when .7 = "1")

.6	.5	.4	OSDCOL.0 = 0	OSDCOL.0 = 1
0	0	0	Black	Color mode 0
0	0	1	Blue	Color mode 1
0	1	0	Green	Color mode 2
0	1	1	Cyan	Color mode 3
1	0	0	Red	Color mode 4
1	0	1	Magenta	Color mode 5
1	1	0	Yellow	Color mode 6
1	1	1	White	Color mode 7

.3 Character Background Color Enable Bit

0	Disable character background color (no background color is displayed)
1	Enable character background color display

.2-.0 Character Background Color Selection Bits (when .3 = "1")

.2	.1	.0	OSDCOL.0 = 0	OSDCOL.0 = 1
0	0	0	Black	Color mode 0
0	0	1	Blue	Color mode 1
0	1	0	Green	Color mode 2
0	1	1	Cyan	Color mode 3
1	0	0	Red	Color mode 4
1	0	1	Magenta	Color mode 5
1	1	0	Yellow	Color mode 6
1	1	1	White	Color mode 7

DSPCON — On-Screen Display Control Register

F5H

Set 1, Bank 1

Bit Identifier	.7	.6	.5	.4	.3	.2	.1	.0
nRESET Value	0	0	0	0	0	0	0	0
Read/Write	R	R	R	R	R/W	R/W	R/W	R/W
Addressing Mode	Register addressing mode only							

.7-.4

OSD Row Counter (Read-only)

0	0	0	0	Row 0
0	0	0	1	Row 1
0	0	1	0	Row 2
0	0	1	1	Row 3
0	1	0	0	Row 4
0	1	0	1	Row 5
0	1	1	0	Row 6
0	1	1	1	Row 7
1	0	0	0	Row 8
1	0	0	1	Row 9
1	0	1	0	Row 10
1	0	1	1	Row 11
Others				1100-1111 are not used

.3

Clock Edge Selection for H/V-Sync Polarity

0	Rising edge
1	Falling edge

.2-.1

Halftone or Background Color Selection Bits

0	0	Character background color
0	1	Not used
1	0	Halftone output
1	1	Character halftone and background color

.0

Display Enable Bit

0	Disable OSD (turn off L-C OSC)
1	Enable OSD (turn on L-C OSC)

EMT — External Memory Timing Register

FEH

Set 1, Bank 0

Bit Identifier	.7	.6	.5	.4	.3	.2	.1	.0
nRESET Value	0	0	0	0	0	0	0	–
Read/Write	R/W	R/W	R/W	R/W	R/W	R/W	R/W	–
Addressing Mode	Register addressing mode only							

.7

External nWAIT Input Function Enable Bit

0	Disable nWAIT input function for external device (normal operating mode)
1	Enable nWAIT input function for external device

.6

Slow Memory Timing Enable Bit

0	Disable slow memory timing
1	Enable slow memory timing

.5 and .4

Program Memory Automatic Wait Control Bits

0	0	No wait (normal operation)
0	1	Wait one cycle
1	0	Wait two cycles
1	1	Wait three cycles

.3 and .2

Data Memory Automatic Wait Control Bits

0	0	No wait (normal operation)
0	1	Wait one cycle
1	0	Wait two cycles
1	1	Wait three cycles

.1

Stack Area Selection Bit

0	Select internal register file area
1	Select external data memory area

.0

Not used for the S3C880A/F880A.

NOTE: Because an external interface is not implemented for the S3C880A/F880A, the EMT values should always be "0".

FADECON — OSD Fade Control Register

F1H

Set 1, Bank 1

Bit Identifier	.7	.6	.5	.4	.3	.2	.1	.0
nRESET Value	–	0	0	0	0	0	0	0
Read/Write	–	R/W	R/W	R/W	R/W	R/W	R/W	R/W
Addressing Mode	Register addressing mode only							

.7

Not used for the S3C880A/F880A.

.6 **Fade Function Enable Bit**

0	Fade disable
1	Fade enable

.5 **Fade Direction Selection Bit**

0	Fade before matrix
1	Fade after matrix

.4–.0 **Halftone or Background Color Selection Bits (1)**

0	0	0	0	0	Line 0
0	0	0	0	1	Line 1
.....				
1	0	0	0	0	Line 16
1	0	0	0	1	Line 17
1	0	0	1	0	Inter-row space Line 1 (1H)
1	0	0	1	1	Inter-row space Line 2 (1H)
1	0	1	0	0	Inter-row space Line 3 (1H)
1	0	1	0	1	Inter-row space Line 4 (1H)
1	0	1	1	0	Inter-row space Line 5 (1H)
1	0	1	1	1	Inter-row space Line 6 (1H)
1	1	0	0	0	Inter-row space Line 7 (1H)
1	1	0	0	1	Not used
.....				
1	1	1	1	1	Not used

NOTE: There are two choices of fade direction: before (FADECON.5="0") and after (FADECON.5="1"). When you select fade before, the character matrix is faded starting with current line +1 (not including current line). When you select fade after, the character matrix is faded starting with current line.

FLAGS — System Flags Register

D5H

Set 1

Bit Identifier	.7	.6	.5	.4	.3	.2	.1	.0
nRESET Value	x	x	x	x	x	x	0	0
Read/Write	R/W	R/W	R/W	R/W	R/W	R/W	R/W	R/W
Addressing Mode	Register addressing mode only							

.7

Carry Flag (C)

0	Operation does not generate a carry or borrow condition
1	Operation generates a carry-out or borrow into high-order bit-7

.6

Zero Flag (Z)

0	Operation result is a non-zero value
1	Operation result is zero

.5

Sign Flag (S)

0	Operation generates a positive number (MSB = "0")
1	Operation generates a negative number (MSB = "1")

.4

Overflow Flag (V)

0	Operation result is $\leq +127$ or ≥ -128
1	Operation result is $> +127$ or < -128

.3

Decimal Adjust Flag (D)

0	Add operation has completed
1	Subtraction operation has completed

.2

Half-Carry Flag (H)

0	No carry-out of bit 3 or no borrow into bit 3 by addition or subtraction
1	Addition generated carry-out of bit 3 or subtraction generated borrow into bit 3

.1

Fast Interrupt Status Flag (FIS)

0	Cleared automatically during an interrupt return (IRET)
1	Automatically set to logic one during a fast interrupt service routine

.0

Bank Address Selection Flag (BA)

0	Bank 0 is selected (using the SB0 instruction)
1	Bank 1 is selected (using the SB1 instruction)

HTCON — Halftone Signal Control Register

F6H

Set 1, Bank 1

Bit Identifier	.7	.6	.5	.4	.3	.2	.1	.0
nRESET Value	0	0	0	0	0	0	0	0
Read/Write	R/W	R/W	R/W	R/W	R/W	R/W	R/W	R/W
Addressing Mode	Register addressing mode only							

.7 Halftone Output Polarity Selection Bit (HT Only)

0	Active high (normal halftone output is Low level)
1	Active low (normal halftone output is High level)

.6 RGB Output Polarity Selection Bit

0	Active high (normal RGB polarity is Low level)
1	Active low (normal RGB polarity is High level)

.5 OSD ROW Interrupt Enable Bit

0	Disable the OSD ROW interrupt
1	Enable the OSD ROW interrupt

.4 OSD ROW Interrupt Pending Bit

0	No interrupt is pending (when read); clear pending bit (when write)
1	Interrupt is pending (when read); no effect (when write)

.3 Halftone Function Enable Bit

0	Disable the halftone control signal
1	Enable the halftone control signal

.2 Halftone Option Selection Bit

0	Halftone output for character periods only (as selected by video RAM bit-13)
1	Halftone output for all frame periods (regardless of video RAM bit-13 setting)

.1 V-Sync Interrupt Enable Bit

0	Disable the V-sync interrupt
1	Enable the V-sync interrupt

.0 V-Sync Interrupt Pending Bit

0	No OSD ROW interrupt is pending (when read)
0	Clear pending bit (when write)
1	OSD ROW interrupt is pending (when read)
1	No effect (when write)

IMR — Interrupt Mask Register

DDH

Set 1

Bit Identifier	.7	.6	.5	.4	.3	.2	.1	.0
nRESET Value	x	x	–	x	x	x	x	x
Read/Write	R/W	R/W	–	R/W	R/W	R/W	R/W	R/W
Addressing Mode	Register addressing mode only							

.7 **Interrupt Priority Level 7 (IRQ7) Enable Bit; V-Sync**

0	Disable IRQ7 interrupt
1	Enable IRQ7 interrupt

.6 **Interrupt Priority Level 6 (IRQ6) Enable Bit; Timer A**

0	Disable IRQ6 interrupt
1	Enable IRQ6 interrupt

.5 Not used for S3C880A/F880A**.4** **Interrupt Priority Level 4 (IRQ4) Enable Bit; P1.2 and P1.3 External Interrupt**

0	Disable IRQ4 interrupt
1	Enable IRQ4 interrupt

.3 **Interrupt Priority Level 3 (IRQ3) Enable Bit; CAPA**

0	Disable IRQ3 interrupt
1	Enable IRQ3 interrupt

.2 **Interrupt Priority Level 2 (IRQ2) Enable Bit; OSD ROW Interrupt**

0	Disable IRQ2 interrupt
1	Enable IRQ2 interrupt

.1 **Interrupt Priority Level 1 (IRQ1) Enable Bit; P1.0 and P1.1 External Interrupt**

0	Disable IRQ1 interrupt
1	Enable IRQ1 interrupt

.0 **Interrupt Priority Level 0 (IRQ0) Enable Bit; T0INT (Match)**

0	Disable IRQ0 interrupt
1	Enable IRQ0 interrupt

IPH — Instruction Pointer (High Byte)

DAH

Set 1

Bit Identifier	.7	.6	.5	.4	.3	.2	.1	.0
nRESET Value	x	x	x	x	x	x	x	x
Read/Write	R/W	R/W	R/W	R/W	R/W	R/W	R/W	R/W
Addressing Mode	Register addressing mode only							

.7-.0

Instruction Pointer Address (High Byte)

The high-byte instruction pointer value is the upper eight bits of the 16-bit instruction pointer address (IP15-IP8). The lower byte of the IP address is located in the IPL register (DBH).

IPL — Instruction Pointer (Low Byte)

DBH

Set 1

Bit Identifier	.7	.6	.5	.4	.3	.2	.1	.0
nRESET Value	x	x	x	x	x	x	x	x
Read/Write	R/W	R/W	R/W	R/W	R/W	R/W	R/W	R/W
Addressing Mode	Register addressing mode only							

.7 - .0

Instruction Pointer Address (Low Byte)

The low-byte instruction pointer value is the lower eight bits of the 16-bit instruction pointer address (IP7-IP0). The upper byte of the IP address is located in the IPH register (DAH).

IPR — Interrupt Priority Register

FFH

Set 1, Bank 0

Bit Identifier	.7	.6	.5	.4	.3	.2	.1	.0
nRESET Value	x	x	–	x	x	x	x	x
Read/Write	R/W	R/W	–	R/W	R/W	R/W	R/W	R/W
Addressing Mode	Register addressing mode only							

.7, .4, and .1

Priority Control Bits for Interrupt Groups A, B, and C (1)

0	0	0	Group priority undefined
0	0	1	B > C > A
0	1	0	A > B > C
0	1	1	B > A > C
1	0	0	C > A > B
1	0	1	C > B > A
1	1	0	A > C > B
1	1	1	Group priority undefined

.6

Interrupt Group C Priority Control Bit

0	IRQ6 > IRQ7
1	IRQ7 > IRQ6

.5

Not used for the S3C880A/F880A (2)

.3

Interrupt Sub Group B Priority Control Bit

0	IRQ3 > IRQ4
1	IRQ4 > IRQ3

.2

Interrupt Group B Priority Control Bit

0	IRQ2 > (IRQ3, IRQ4)
1	(IRQ3, IRQ4) > IRQ2

.0

Interrupt Group A Priority Control Bit

0	IRQ0 > IRQ1
1	IRQ1 > IRQ0

NOTES:

1. Interrupt group A is IRQ0 and IRQ1; interrupt group B is IRQ2, IRQ3, and IRQ4; interrupt group C is IRQ6 and IRQ7.
2. Interrupt level IRQ5 is not used in the S3C880A/F880A interrupt structure. For this reason, IPR.5 is not used.

IRQ — Interrupt Request Register

DCH

Set 1

Bit Identifier	.7	.6	.5	.4	.3	.2	.1	.0
nRESET Value	0	0	–	0	0	0	0	0
Read/Write	R	R	–	R	R	R	R	R
Addressing Mode	Register addressing mode only							

.7 Interrupt Level 7 (IRQ7) Request Pending Bit; V-Sync

0	No IRQ7 interrupt pending
1	IRQ7 interrupt is pending

.6 Interrupt Level 6 (IRQ6) Request Pending Bit; Timer A

0	No IRQ6 interrupt pending
1	IRQ6 interrupt is pending

.5 Not used for the S3C880A/F880A**.4 Interrupt Level 4 (IRQ4) Request Pending Bit; P1.2 and P1.3 External Interrupt**

0	No IRQ4 interrupt pending
1	IRQ4 interrupt is pending

.3 Interrupt Level 3 (IRQ3) Request Pending Bit; CAPA

0	No IRQ3 interrupt pending
1	IRQ3 interrupt is pending

.2 Interrupt Level 2 (IRQ2) Request Pending Bit; OSD ROW Interrupt

0	No IRQ2 interrupt pending
1	IRQ2 interrupt is pending

.1 Interrupt Level 1 (IRQ1) Request Pending Bit; P1.0 and P1.1 External Interrupt

0	No IRQ1 interrupt pending
1	IRQ1 interrupt is pending

.0 Interrupt Level 0 (IRQ0) Request Pending Bit; T0INT (Match)

0	No IRQ0 interrupt pending
1	IRQ0 interrupt is pending

NOTE: Interrupt level request pending bits can be polled by software to detect an interrupt request pending condition on any of the seven valid interrupt levels (IRQ0–IRQ4, IRQ6, and IRQ7). Interrupt pending bits are read-only addressable.

OSDCOL — OSD Space Color Control Register

E4H

Set 1, Bank 1

Bit Identifier	.7	.6	.5	.4	.3	.2	.1	.0
nRESET Value	–	–	–	0	0	0	0	0
Read/Write	–	–	–	R/W	R/W	R/W	R/W	R/W
Addressing Mode	Register addressing mode only							

.7–,5

Not used for the S3C880A/F880A.

.4

Inter Character Smoothing Control Bit (note)

0	Disable inter character smoothing
1	Enable inter character smoothing

.3

Fringe Dot Size Selection Bit

0	1 dot
1	1/2 dot

.2

Inter-row Space Half Tone

0	Depend on character background half tone
1	Depend on frame background half tone

.1

Inter-row Space Color

0	Depend on character background color
1	Depend on frame background color

.0

RGB Output Selection Bit

0	Digital RGB output (disable palette color mode)
1	Analog RGB output (enable palette color mode)

NOTE: In 1-dot fringe mode (OSDCOL.3 = "0"), Inter-character smooth function is disabled.

OSDFLD — OSD Field Control Register

E5H

Set 1, Bank 1

Bit Identifier	.7	.6	.5	.4	.3	.2	.1	.0
nRESET Value	–	–	x	0	0	1	1	0
Read/Write	–	–	R	R/W	R/W	R/W	R/W	R/W
Addressing Mode	Register addressing mode only							

.7–.6

Not used for the S3C880A/F880A.

.5 **Field Data (Read Only)**

0	Even field
1	Odd field

.4 **H-sync Detect Position Select Bit**

0	Detect H-sync before V-sync
1	Detect H-sync after V-sync

.3–.0 **Even Field Range**

0	0	0	0	Not used
0	0	0	1	$f_{\text{CPU}}/16 \times 1$
0	0	1	0	$f_{\text{CPU}}/16 \times 2$
0	0	1	1	$f_{\text{CPU}}/16 \times 3$
0	1	0	0	$f_{\text{CPU}}/16 \times 4$
0	1	0	1	$f_{\text{CPU}}/16 \times 5$
0	1	1	0	$f_{\text{CPU}}/16 \times 6$ (Reset value)
0	1	1	1	$f_{\text{CPU}}/16 \times 7$
1	0	0	0	$f_{\text{CPU}}/16 \times 8$
1	0	0	1	$f_{\text{CPU}}/16 \times 9$
1	0	1	0	$f_{\text{CPU}}/16 \times 10$
1	0	1	1	$f_{\text{CPU}}/16 \times 11$
1	1	0	0	$f_{\text{CPU}}/16 \times 12$
1	1	0	1	$f_{\text{CPU}}/16 \times 13$
1	1	1	0	$f_{\text{CPU}}/16 \times 14$
1	1	1	1	$f_{\text{CPU}}/16 \times 15$

OSDFRG1 — OSD Fringe/Border Control Register 1

E0H

Set 1, Bank 1

Bit Identifier	.7	.6	.5	.4	.3	.2	.1	.0
nRESET Value	0	0	0	0	0	0	0	0
Read/Write	R/W	R/W	R/W	R/W	R/W	R/W	R/W	R/W
Addressing Mode	Register addressing mode only							

.7–.0

Fringe/Border Function Enable Bit

0	Disable Fringe/Border function at row n (n = 0–7)
1	Enable Fringe/Border function at row n (n = 0–7)

NOTE: Row n is respectively correspond with bit n (n = 0–7).

OSDFRG2— OSD Fringe/Border Control Register 2

E1H

Set 1, Bank 1

Bit Identifier	.7	.6	.5	.4	.3	.2	.1	.0
nRESET Value	0	0	0	0	0	0	0	0
Read/Write	R/W	R/W	R/W	R/W	R/W	R/W	R/W	R/W
Addressing Mode	Register addressing mode only							

.7

Fringe or Border Selection Bit

0	Border function select
1	Fringe function select

.6–.4

Fringe/Border Color Selection Bits (.6: Red, .5: Green, .4: Blue)

.6	.5	.4	OSDCOL.0 = 0	OSDCOL.0 = 1
0	0	0	Black	Color mode 0
0	0	1	Blue	Color mode 1
0	1	0	Green	Color mode 2
0	1	1	Cyan	Color mode 3
1	0	0	Red	Color mode 4
1	0	1	Magenta	Color mode 5
1	1	0	Yellow	Color mode 6
1	1	1	White	Color mode 7

.3–.0

Fringe/Border Function Enable Bits

0	Disable Fringe/Border function at row n (n = 8–11)
1	Enable Fringe/Border function at row n (n = 8–11)

NOTE: Row 8, row 9, row 10, row 11 are correspond with bit 0, bit 1, bit 2, bit3, respectively.

OSDPLTB1 — OSD Palette Color Mode Register B1

EAH

Set 1, Bank 1

Bit Identifier	.7	.6	.5	.4	.3	.2	.1	.0
nRESET Value	1	1	0	0	1	1	0	0
Read/Write	R/W	R/W	R/W	R/W	R/W	R/W	R/W	R/W
Addressing Mode	Register addressing mode only							

.7–.6

OSD Mode 3 Blue Level

0	0	Disable
0	1	33 %
1	0	66 %
1	1	100 %

.5–.4

OSD Mode 2 Blue Level

0	0	Disable
0	1	33 %
1	0	66 %
1	1	100 %

.3–.2

OSD Mode 1 Blue Level

0	0	Disable
0	1	33 %
1	0	66 %
1	1	100 %

.1–.0

OSD Mode 1 Blue Level

0	0	Disable
0	1	33 %
1	0	66 %
1	1	100 %

OSDPLTB2 — OSD Palette Color Mode Register B2

EBH

Set 1, Bank 1

Bit Identifier	.7	.6	.5	.4	.3	.2	.1	.0
nRESET Value	1	1	0	0	1	1	0	0
Read/Write	R/W	R/W	R/W	R/W	R/W	R/W	R/W	R/W
Addressing Mode	Register addressing mode only							

.7–.6**OSD Mode 7 Blue Level**

0	0	Disable
0	1	33 %
1	0	66 %
1	1	100 %

.5–.4**OSD Mode 6 Blue Level**

0	0	Disable
0	1	33 %
1	0	66 %
1	1	100 %

.3–.2**OSD Mode 5 Blue Level**

0	0	Disable
0	1	33 %
1	0	66 %
1	1	100 %

.1–.0**OSD Mode 4 Blue Level**

0	0	Disable
0	1	33 %
1	0	66 %
1	1	100 %

OSDPLTG1 — OSD Palette Color Mode Register G1

E8H

Set 1, Bank 1

Bit Identifier	.7	.6	.5	.4	.3	.2	.1	.0
nRESET Value	1	1	1	1	0	0	0	0
Read/Write	R/W	R/W	R/W	R/W	R/W	R/W	R/W	R/W
Addressing Mode	Register addressing mode only							

.7–.6

OSD Mode 3 Green Level

0	0	Disable
0	1	33 %
1	0	66 %
1	1	100 %

.5–.4

OSD Mode 2 Green Level

0	0	Disable
0	1	33 %
1	0	66 %
1	1	100 %

.3–.2

OSD Mode 1 Green Level

0	0	Disable
0	1	33 %
1	0	66 %
1	1	100 %

.1–.0

OSD Mode 1 Green Level

0	0	Disable
0	1	33 %
1	0	66 %
1	1	100 %

OSDPLTG2— OSD Palette Color Mode Register G2

E9H

Set 1, Bank 1

Bit Identifier	.7	.6	.5	.4	.3	.2	.1	.0
nRESET Value	1	1	1	1	0	0	0	0
Read/Write	R/W	R/W	R/W	R/W	R/W	R/W	R/W	R/W
Addressing Mode	Register addressing mode only							

.7–.6**OSD Mode 7 Green Level**

0	0	Disable
0	1	33 %
1	0	66 %
1	1	100 %

.5–.4**OSD Mode 6 Green Level**

0	0	Disable
0	1	33 %
1	0	66 %
1	1	100 %

.3–.2**OSD Mode 5 Green Level**

0	0	Disable
0	1	33 %
1	0	66 %
1	1	100 %

.1–.0**OSD Mode 4 Green Level**

0	0	Disable
0	1	33 %
1	0	66 %
1	1	100 %

OSDPLTR1 — OSD Palette Color Mode Register R1

E6H

Set 1, Bank 1

Bit Identifier	.7	.6	.5	.4	.3	.2	.1	.0
nRESET Value	0	0	0	0	0	0	0	0
Read/Write	R/W	R/W	R/W	R/W	R/W	R/W	R/W	R/W
Addressing Mode	Register addressing mode only							

.7–.6**OSD Mode 3 Red Level**

0	0	Disable
0	1	33 %
1	0	66 %
1	1	100 %

.5–.4**OSD Mode 2 Red Level**

0	0	Disable
0	1	33 %
1	0	66 %
1	1	100 %

.3–.2**OSD Mode 1 Red Level**

0	0	Disable
0	1	33 %
1	0	66 %
1	1	100 %

.1–.0**OSD Mode 1 Red Level**

0	0	Disable
0	1	33 %
1	0	66 %
1	1	100 %

OSDPLTR2 — OSD Palette Color Mode Register R2

E7H

Set 1, Bank 1

Bit Identifier	.7	.6	.5	.4	.3	.2	.1	.0
nRESET Value	1	1	1	1	1	1	1	1
Read/Write	R/W	R/W	R/W	R/W	R/W	R/W	R/W	R/W
Addressing Mode	Register addressing mode only							

.7–.6**OSD Mode 7 Red Level**

0	0	Disable
0	1	33 %
1	0	66 %
1	1	100 %

.5–.4**OSD Mode 6 Red Level**

0	0	Disable
0	1	33 %
1	0	66 %
1	1	100 %

.3–.2**OSD Mode 5 Red Level**

0	0	Disable
0	1	33 %
1	0	66 %
1	1	100 %

.1–.0**OSD Mode 4 Red Level**

0	0	Disable
0	1	33 %
1	0	66 %
1	1	100 %

OSDSMH1 — OSD Smooth Control Register 1

E2H

Set 1, Bank 1

Bit Identifier	.7	.6	.5	.4	.3	.2	.1	.0
nRESET Value	0	0	0	0	0	0	0	0
Read/Write	R/W	R/W	R/W	R/W	R/W	R/W	R/W	R/W
Addressing Mode	Register addressing mode only							

.7 Row 7 Smooth Function Enable Bit

0	Disable smooth function at Row 7
1	Enable smooth function at Row 7

.6 Row 6 Smooth Function Enable Bit

0	Disable smooth function at Row 6
1	Enable smooth function at Row 6

.5 Row 5 Smooth Function Enable Bit

0	Disable smooth function at Row 5
1	Enable smooth function at Row 5

.4 Row 4 Smooth Function Enable Bit

0	Disable smooth function at Row 4
1	Enable smooth function at Row 4

.3 Row 3 Smooth Function Enable Bit

0	Disable smooth function at Row 3
1	Enable smooth function at Row 3

.2 Row 2 Smooth Function Enable Bit

0	Disable smooth function at Row 2
1	Enable smooth function at Row 2

.1 Row 1 Smooth Function Enable Bit

0	Disable smooth function at Row 1
1	Enable smooth function at Row 1

.0 Row 0 Smooth Function Enable Bit

0	Disable smooth function at Row 0
1	Enable smooth function at Row 0

OSDSMH2 — OSD Smooth Control Register 2**E3H****Set 1, Bank 1**

Bit Identifier	.7	.6	.5	.4	.3	.2	.1	.0
nRESET Value	–	–	–	–	0	0	0	0
Read/Write	–	–	–	–	R/W	R/W	R/W	R/W
Addressing Mode	Register addressing mode only							

.7–.4

Not used for the S3C880A/F880A

.3

Row 11 Smooth Function Enable Bit

0	Disable smooth function at Row 11
1	Enable smooth function at Row 11

.2

Row 10 Smooth Function Enable Bit

0	Disable smooth function at Row 10
1	Enable smooth function at Row 10

.1

Row 9 Smooth Function Enable Bit

0	Disable smooth function at Row 9
1	Enable smooth function at Row 9

.0

Row 8 Smooth Function Enable Bit

0	Disable smooth function at Row 8
1	Enable smooth function at Row 8

P0CONH — Port 0 Control Register (High Byte)

E4H

Set 1, Bank 0

Bit Identifier	.7	.6	.5	.4	.3	.2	.1	.0
nRESET Value	1	1	1	1	0	0	0	0
Read/Write	R/W	R/W	R/W	R/W	R/W	R/W	R/W	R/W
Addressing Mode	Register addressing mode only							

.7 and .6**Port 0.7 Configuration Bits**

0	0	Input mode
0	1	ADC Input mode
1	0	Open-drain output mode
1	1	Open-drain output mode

.5 and .4**Port 0.6 Configuration Bits**

0	0	Input mode
0	1	ADC Input mode
1	0	Open-drain output mode
1	1	Open-drain output mode

.3 and .2**Port 0.5 Configuration Bits**

0	0	Input mode
0	1	Input mode
1	0	Push-pull output mode
1	1	Push-pull output mode

.1 and .0**Port 0.4 Configuration Bits**

0	0	Input mode
0	1	Input mode
1	0	Push-pull output mode
1	1	Push-pull output mode

P0CONL — Port 0 Control Register (Low Byte)

E5H

Set 1, Bank 0

Bit Identifier	.7	.6	.5	.4	.3	.2	.1	.0
nRESET Value	0	0	0	0	0	0	0	0
Read/Write	R/W	R/W	R/W	R/W	R/W	R/W	R/W	R/W
Addressing Mode	Register addressing mode only							

.7 and .6**Port 0.3 Configuration Bits**

0	0	Input mode
0	1	Input mode
1	0	N-channel open-drain output mode (5 V load)
1	1	Push-pull output mode

.5 and .4**Port 0.2 Configuration Bits**

0	0	Input mode
0	1	Input mode
1	0	N-channel open-drain output mode (5 V load)
1	1	Push-pull output mode

.3 and .2**Port 0.1 Configuration Bits**

0	0	Input mode
0	1	Input mode
1	0	N-channel open-drain output mode (5 V load)
1	1	Push-pull output mode

.1 and .0**Port 0.0 Configuration Bits**

0	0	Input mode
0	1	Input mode
1	0	N-channel open-drain output mode (5 V load)
1	1	Push-pull output mode

P1CONH — Port 1 Control Register (High Byte)

E6H

Set 1, Bank 0

Bit Identifier	.7	.6	.5	.4	.3	.2	.1	.0
nRESET Value	0	0	0	0	1	1	1	1
Read/Write	R/W	R/W	R/W	R/W	R/W	R/W	R/W	R/W
Addressing Mode	Register addressing mode only							

.7 and .6

Port 1.7/T0CK Configuration Bits

0	0	Input mode
0	1	Timer 0 clock Input mode
1	0	Push-pull output mode
1	1	Push-pull output mode

.5 and .4

Port 1.6 Configuration Bits

0	0	Input mode
0	1	Input mode
1	0	Push-pull output mode
1	1	Push-pull output mode

.3 and .2

Port 1.5 Configuration Bits

0	0	Input mode
0	1	Input mode
1	0	N-channel open-drain mode (6-volt load capacity)
1	1	N-channel open-drain mode (6-volt load capacity)

.1 and .0

Port 1.4 Configuration Bits

0	0	Input mode
0	1	Input mode
1	0	N-channel open-drain mode (6-volt load capacity)
1	1	N-channel open-drain mode (6-volt load capacity)

P1CONL — Port 1 Control Register (Low Byte)

E7H

Set 1, Bank 0

Bit Identifier	.7	.6	.5	.4	.3	.2	.1	.0
nRESET Value	1	1	1	1	1	1	1	1
Read/Write	R/W	R/W	R/W	R/W	R/W	R/W	R/W	R/W
Addressing Mode	Register addressing mode only							

.7 and .6**Port 1.3/INT3 Configuration Bits**

0	0	Input mode; interrupt disabled
0	1	Input mode; interrupt on rising edge
1	0	Input mode; interrupt on falling edge
1	1	N-channel open-drain output mode (6-volt load capacity)

.5 and .4**Port 1.2/INT2 Configuration Bits**

0	0	Input mode; interrupt disabled
0	1	Input mode; interrupt on rising edge
1	0	Input mode; interrupt on falling edge
1	1	N-channel open-drain output mode (6-volt load capacity)

.3 and .2**Port 1.1/INT1 Configuration Bits**

0	0	Input mode; interrupt disabled
0	1	Input mode; interrupt on rising edge
1	0	Input mode; interrupt on falling edge
1	1	N-channel open-drain output mode (6-volt load capacity)

.1 and .0**Port 1.0/INT0 Configuration Bits**

0	0	Input mode; interrupt disabled
0	1	Input mode; interrupt on rising edge
1	0	Input mode; interrupt on falling edge
1	1	N-channel open-drain output mode (6-volt load capacity)

P2CONH — Port 2 Control Register (High Byte)

E8H

Set 1, Bank 0

Bit Identifier	.7	.6	.5	.4	.3	.2	.1	.0
nRESET Value	0	0	0	0	0	0	0	0
Read/Write	R/W	R/W	R/W	R/W	R/W	R/W	R/W	R/W
Addressing Mode	Register addressing mode only							

.7 and .6**Port 2.7/OSDHT Configuration Bits**

0	0	Input mode
0	1	N-channel open-drain output mode (5-volt load capacity)
1	0	Push-pull output mode
1	1	OSD half-tone output mode (push-pull circuit type)

.5 and .4**Port 2.6/T0 Configuration Bits**

0	0	Input mode
0	1	N-channel open-drain output mode (5-volt load capacity)
1	0	Push-pull output mode
1	1	Timer 0 output mode (interval or PWM; N-channel open-drain type)

.3 and .2**Port 2.5/PWM0 Configuration Bits**

0	0	Input mode
0	1	N-channel open-drain output mode (5-volt load capacity)
1	0	Push-pull output mode
1	1	PWM0 output mode (push-pull circuit type)

.1 and .0**Port 2.4/PWM4 Configuration Bits**

0	0	Input mode
0	1	N-channel open-drain output mode (5-volt load capacity)
1	0	Push-pull output mode
1	1	PWM4 output mode (N-channel open-drain type)

P2CONL — Port 2 Control Register (Low Byte)

E9H

Set 1, Bank 0

Bit Identifier	.7	.6	.5	.4	.3	.2	.1	.0
nRESET Value	0	0	0	0	0	0	0	0
Read/Write	R/W	R/W	R/W	R/W	R/W	R/W	R/W	R/W
Addressing Mode	Register addressing mode only							

.7 and .6

Port 2.3/PWM3 Configuration Bits

0	0	Normal input mode
0	1	Normal input mode
1	0	PWM3 output mode; N-channel, open-drain output mode With 5-volt load capacity
1	1	Push-pull output mode

.5 and .4

Port 2.2/PWM2 Configuration Bits

0	0	Normal input mode
0	1	Normal input mode
1	0	PWM2 output mode; N-channel, open-drain output mode With 5-volt load capacity
1	1	Push-pull output mode

.3 and .2

Port 2.1/PWM1 Configuration Bits

0	0	Normal input mode
0	1	Normal input mode
1	0	PWM1 output mode; N-channel, open-drain output mode With 5-volt load capacity
1	1	Push-pull output mode

.1 and .0

Port 2.0/PWM5 Configuration Bits

0	0	Normal input mode
0	1	Normal input mode
1	0	PWM5 output mode; N-channel, open-drain output mode With 5-volt load capacity
1	1	Push-pull output mode



P3CONL — Port 3 Control Register (Low Byte)

EBH

Set 1, Bank 0

Bit Identifier	.7	.6	.5	.4	.3	.2	.1	.0
nRESET Value	–	–	–	–	1	1	1	1
Read/Write	–	–	–	–	R/W	R/W	R/W	R/W
Addressing Mode	Register addressing mode only							

.7 – .4

No effect

.3 and .2

Port 3.1/ADC1 Configuration Bits

0	0	Input mode
0	1	ADC input mode
1	0	Input mode
1	1	N-channel, open-drain output mode with 5-volt load capacity

.1 and .0

Port 3.0/ADC0 Configuration Bits

0	0	Input mode
0	1	ADC input mode
1	0	Input mode
1	1	N-channel, open-drain output mode with 5-volt load capacity

PP — Register Page Pointer

DFH

Set 1

Bit Identifier	.7	.6	.5	.4	.3	.2	.1	.0
nRESET Value	0	0	0	0	0	0	0	0
Read/Write	R/W	R/W	R/W	R/W	R/W	R/W	R/W	R/W
Addressing Mode	Register addressing mode only							

.7-.4

Destination Register Page Selection Bits

0	0	0	0	Destination: page 0
0	0	0	1	Destination: page 1
0	0	1	0	Destination: page 2
0	0	1	1	Not used for the S3C880A/F880A
...				"
1	1	1	1	Not used for the S3C880A/F880A

.3-.0

Source Register Page Selection Bits

0	0	0	0	Source: page 0
0	0	0	1	Source: page 1
0	0	1	0	Source: page 2
0	0	1	1	Not used for the S3C880A/F880A
...				"
1	1	1	1	Not used for the S3C880A/F880A

PWMCON — PWM Control Register

F8H

Set 1, Bank 0

Bit Identifier	.7	.6	.5	.4	.3	.2	.1	.0
nRESET Value	0	0	0	0	0	–	0	0
Read/Write	R/W	R/W	R/W	R/W	R/W	–	R/W	R/W
Addressing Mode	Register addressing mode only							

.4, .7, and .6

3-Bit Prescaler Value for PWM Counter Input Clock

0	0	0	Non-divided input clock
0	0	1	Divided-by-two input clock
0	1	0	Divided-by-three input clock
0	1	1	Divided-by-four input clock
1	0	0	Divided-by-five input clock
1	0	1	Divided-by-six input clock
1	1	0	Divided-by-seven input clock
1	1	1	Divided-by-eight input clock

.5

PWM Counter Enable Bit

0	Stop PWM counter operation
1	Start (or resume) PWM counter operation

.3

Capture A Interrupt Enable Bit

0	Disable capture A interrupt
1	Enable capture A interrupt

.2

Not used for the S3C880A/F880A

.1 and .0

Capture A Module Control Bits

0	0	Disable capture A module
0	1	Capture on falling edges only
1	0	Capture on rising edges only
1	1	Capture on both rising and falling edges

ROWCON — OSD Row Position Control Register F2H Set 1, Bank 1

Bit Identifier	.7	.6	.5	.4	.3	.2	.1	.0
nRESET Value	0	0	0	0	0	0	0	0
Read/Write	R/W	R/W	R/W	R/W	R/W	R/W	R/W	R/W
Addressing Mode	Register addressing mode only							

.7–.3 Top Margin Display Position Control Value (4 x TMG value of 0–31 dots)

0	0	0	0	0	Top margin position = 0H
0	0	0	0	1	Top margin position = 4H
...					...
1	1	1	1	1	Top margin position = 124H

.2–.0 Inter-Row Spacing Control Value (0–7H)

0	0	0	No inter-row spacing
0	0	1	Inter-row spacing = 1H
...			...
1	1	1	Inter-row spacing = 7H

NOTE: To set top margin and inter-row spacing, separate decimal values must be calculated, converted to their binary equivalents, and then written to the ROWCON register.

RP0 — Register Pointer 0**D6H****Set 1**

Bit Identifier	.7	.6	.5	.4	.3	.2	.1	.0
nRESET Value	1	1	0	0	0	–	–	–
Read/Write	R/W	R/W	R/W	R/W	R/W	–	–	–
Addressing Mode	Register addressing mode only							

.7–.3**Register Pointer 0 Address Value**

Register pointer 0 can independently point to one of the twenty four 8-byte working register areas in the register file. Using the register pointers RP0 and RP1, you can select two 8-byte register slices at one time as active working register space. After a reset, RP0 points to the address C0H in the register set 1, selecting the 8-byte working register slice C0H–C7H.

.2–.0

Not used for the S3C880A/F880A.

RP1 — Register Pointer 1**D7H****Set 1**

Bit Identifier	.7	.6	.5	.4	.3	.2	.1	.0
nRESET Value	1	1	0	0	1	–	–	–
Read/Write	R/W	R/W	R/W	R/W	R/W	–	–	–
Addressing Mode	Register addressing mode only							

.7–.3**Register Pointer 1 Address Value**

Register pointer 1 can independently point to one of the twenty four 8-byte working register areas in the register file. Using the register pointers RP0 and RP1, you can select two 8-byte register slices at one time as active working register space. After a reset, RP1 points to the address C8H in the register set 1, selecting the 8-byte working register slice C8H–CFH.

.2–.0

Not used for the S3C880A/F880A.

SPH — Stack Pointer (High Byte)

D8H

Set 1

Bit Identifier	.7	.6	.5	.4	.3	.2	.1	.0
nRESET Value	x	x	x	x	x	x	x	x
Read/Write	R/W	R/W	R/W	R/W	R/W	R/W	R/W	R/W
Addressing Mode	Register addressing mode only							

.7–.0

Stack Pointer Address (High Byte)

The high-byte stack pointer value is the upper 8 bits of the 16-bit stack pointer address (SP15–SP8). The lower byte of the stack pointer value is located in the register SPL (D9H). The SP value is undefined after a reset.

SPL — Stack Pointer (Low Byte)

D9H

Set 1

Bit Identifier	.7	.6	.5	.4	.3	.2	.1	.0
nRESET Value	x	x	x	x	x	x	x	x
Read/Write	R/W	R/W	R/W	R/W	R/W	R/W	R/W	R/W
Addressing Mode	Register addressing mode only							

.7–.0

Stack Pointer Address (Low Byte)

The low-byte stack pointer value is the lower 8 bits of the 16-bit stack pointer address (SP7–SP0). The upper byte of the stack pointer value is located in the register SPH (D8H). The SP value is undefined after a reset.

STCON — Stop Control Register

F3H

Set 1, Bank 0

Bit Identifier	.7	.6	.5	.4	.3	.2	.1	.0
nRESET Value	0	0	0	0	0	0	0	0
Read/Write	R/W	R/W	R/W	R/W	R/W	R/W	R/W	R/W
Addressing Mode	Register addressing mode only							

.7-.0

Stop Condition Enable Bits

Other set value	Stop Condition Disable (Stop instruction is not available)
10100101	Stop Condition Enable (Stop instruction is available)

NOTE: When the Stop control register, STCON, is set by '10100101B', Stop instruction is available. The other value except '10100101B' make Stop instruction not available. When Stop condition is disabled, using "stop" instruction make state reset. Once Stop instruction is executed in state of STOP instruction available, the state is changed to Stop instruction not available.

SYM — System Mode Register

DEH

Set 1

Bit Identifier	.7	.6	.5	.4	.3	.2	.1	.0
nRESET Value	0	–	–	x	x	x	0	0
Read/Write	R/W	–	–	R/W	R/W	R/W	R/W	R/W
Addressing Mode	Register addressing mode only							

.7 **Tri-State External Interface Control Bit** ⁽¹⁾

0	Normal operation (disable tri-state operation)
1	Set external interface lines to high impedance (enable tri-state operation)

.6–.5 Not used for the S3C880A/F880A.**.4–.2** **Fast Interrupt Level Selection Bits**

0	0	0	Level 0 (IRQ0)
0	0	1	Level 1 (IRQ1)
0	1	0	Level 2 (IRQ2)
0	1	1	Level 3 (IRQ3)
1	0	0	Level 4 (IRQ4)
1	0	1	Not used for S3C880A/F880A
1	1	0	Level 6 (IRQ6)
1	1	1	Level 7 (IRQ7)

.1 **Fast Interrupt Enable Bit**

0	Disable fast interrupt processing
1	Enable fast interrupt processing

.0 **Global Interrupt Enable Bit** ⁽²⁾

0	Disable global interrupt processing
1	Enable global interrupt processing

NOTES:

1. Because the S3C880A/F880A microcontrollers do not have an external interface, bit 7 should always be "0".
2. After a reset, the initialization routine must enable global interrupt processing by executing an EI instruction (and not by writing a "1" to SYM.0).

TACON — Timer A Control Register

F2H

Set 1, Bank 0

Bit Identifier	.7	.6	.5	.4	.3	.2	.1	.0
nRESET Value	0	0	0	0	0	0	0	–
Read/Write	R/W	R/W	R/W	R/W	R/W	R/W	R/W	–
Addressing Mode	Register addressing mode only							

.7–.4

4-Bit Prescaler for Timer A Clock Input							
0	0	0	0	Divide input by 1 (non-divided)			
0	0	0	1	Divide input by 2			
...			...				
1	1	1	1	Divide input by 16			

.3

Timer A Clock Source Selection Bit

0	CPU clock divided by 1000
1	Non-divided CPU clock

.2

Timer A Interrupt Enable Bit

0	Disable interrupt
1	Enable interrupt

.1

Timer A Interrupt Pending Bit

0	No interrupt pending (when read)
0	<i>Clear pending bit (when write)</i>
1	Interrupt is pending (when read)
1	<i>No effect (when write)</i>

.0

Not used for the S3C880A/F880A	
--------------------------------	--

T0CON— Timer 0 Control Register

D2H

Set 1

Bit Identifier	.7	.6	.5	.4	.3	.2	.1	.0
nRESET Value	0	0	0	0	0	–	0	0
Read/Write	R/W	R/W	R/W	R/W	R/W	–	R/W	R/W
Addressing Mode	Register addressing mode only							

.7 and .6**T0 Input Clock Selection Bits**

0	0	$f_{OSC}/4096$
0	1	$f_{OSC}/256$
1	0	$f_{OSC}/8$
1	1	External clock (T0CLK)

.5 and .4**T0 Operating Mode Selection Bits**

0	0	Interval mode
0	1	PWM mode
1	0	PWM mode
1	1	PWM mode

.3**T0 Counter Clear Bit**

0	No effect
1	Clear the T0 counter (when write)

.2

No effect

.1**T0 Interrupt Enable Bit**

0	Disable T0 interrupt
1	Enable T0 interrupt

.0**T0 Interrupt Pending Bit**

0	No timer 0 interrupt pending (when read)
0	Clear timer 0 pending bit (when write)
1	Timer 0 interrupt is pending (when read)
1	No effect (when write)

VSBCON— V-SYNC Blank Control Register

F7H

Set 1, Bank1

Bit Identifier	.7	.6	.5	.4	.3	.2	.1	.0
nRESET Value	–	–	–	0	1	0	0	1
Read/Write	–	–	–	R/W	R/W	R/W	R/W	R/W
Addressing Mode	Register addressing mode only							

.7 and .5

Not used for the S3C880A/F880A

.4–.0

V-SYNC Blank Time Control Bits:

0	0	0	0	0	9 Horizontal Sync
...					''
0	1	0	0	1	9 Horizontal Sync
0	1	0	1	0	10 Horizontal Sync
0	1	0	1	1	11 Horizontal Sync
...					...
1	1	1	1	1	31 Horizontal Sync

5 INTERRUPT STRUCTURE

OVERVIEW

The SAM87 interrupt structure has three basic components: levels, vectors, and sources. The CPU recognizes 8 interrupt levels and supports up to 128 interrupt vectors. When a specific interrupt level has more than one vector address, the vector priorities are established in hardware. Each vector can have one or more interrupt sources.

Levels

Levels provide the highest-level method of interrupt priority assignment and recognition. All peripherals and I/O blocks can issue interrupt requests. In other words, peripheral and I/O operations are interrupt-driven. There are eight interrupt levels: IRQ0–IRQ7. Each interrupt level directly corresponds to an interrupt request number (IRQn). The total number of interrupt levels used in the interrupt structure varies from device to device. For the S3C880A/F880A microcontrollers, seven levels are recognized: IRQ0–IRQ4, IRQ6, and IRQ7.

The interrupt level numbers 0 through 7 do not necessarily indicate the relative priority of the levels. They are simply identifiers for the interrupt levels that are recognized by the CPU (IRQ0–IRQ7). The relative priority of different interrupt levels is determined by settings in the interrupt priority register, IPR. Interrupt logic controlled by the IPR settings lets you define additional priority relationship for specific interrupt levels.

Vectors

Each interrupt level can have one or more interrupt vectors, or it may have no vector address assigned at all. The maximum number of vectors that can be supported for a given level is 128. (The actual number of vectors used for the S3C8-series microcontrollers is always much smaller.) If an interrupt level has more than one vector address, the vector priorities are set in hardware. The S3C880A/F880A have 9 vectors, one corresponding to each of the 9 possible sources.

Sources

A source is any peripheral that generates an interrupt. A source can be an external pin or a counter overflow, for example. Each vector can have several interrupt sources. In the S3C880A/F880A interrupt structure, each source has its own vector address. When a service routine starts, the respective pending bit is either cleared automatically by hardware or "manually" by the program software. The characteristics of the source's pending mechanism determine which method is used to clear its pending bit.

INTERRUPT TYPES

The three components of the SAM87 interrupt structure described above — levels, vectors, and sources — are combined to determine the interrupt structure of an individual device and to make full use of its available interrupt logic. There are three possible combinations of interrupt structure components, called interrupt types 1, 2, and 3. The types differ in the number of vectors and interrupt sources assigned to each level (see Figure 5-1):

- Type 1: One level (IRQn) + one vector (V_1) + one source (S_1)
- Type 2: One level (IRQn) + one vector (V_1) + multiple sources ($S_1 - S_n$)
- Type 3: One level (IRQn) + multiple vectors ($V_1 - V_n$) + multiple sources ($S_1 - S_n, S_{n+1} - S_{n+m}$)

In the S3C880A/F880A interrupt structure, only interrupt types 1 and 3 are implemented.

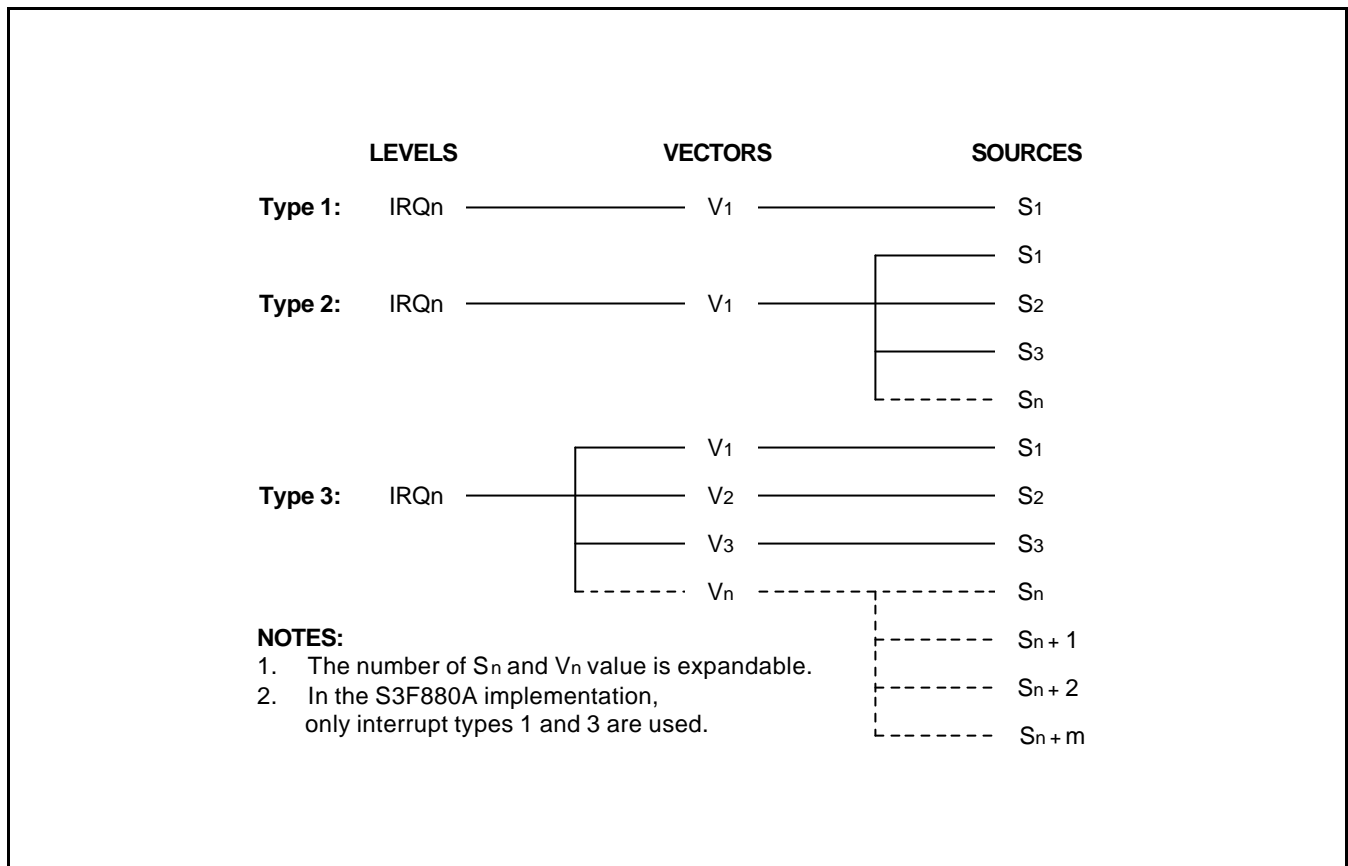


Figure 5-1. S3C8-Series Interrupt Types

S3C880A/F880A INTERRUPT STRUCTURE

The S3C880A/F880A microcontrollers have 9 standard interrupt sources. Nine different vector addresses are used to support these interrupt sources. Seven of the eight available levels are used for the interrupt structure: IRQ0–IRQ4, IRQ6, and IRQ7. The device-specific interrupt structure is shown in Figure 5-2.

When multiple interrupt levels are active, the interrupt priority register (IPR) determines the order in which contending interrupts are to be serviced. If multiple interrupts occur within the same interrupt level, the interrupt with the lowest vector address is usually processed first. (The relative priorities of multiple interrupts within a single level are hardwired.)

When an interrupt request is granted, interrupt processing starts: subsequent interrupts are disabled and the program counter value and status flags are pushed to stack. The starting address of the service routine is fetched from the appropriate vector address (plus the next 8-bit value to concatenate the full 16-bit address) and the service routine is executed.

LEVELS	VECTORS	SOURCES	IDENTIFIER	RESET
IRQ0	FCH	Timer 0 interrupt (match)	T0INT	S/W
IRQ1	C0H	0 P1.0 external interrupt	P10INT	H/W
	C2H	1 P1.1 external interrupt	P11INT	H/W
IRQ2	C4H	OSD ROW interrupt	ROWINT	S/W
IRQ3	02H	Capture A (8-bit)	CAPA	H/W
IRQ4	C6H	0 P1.2 external interrupt	P12INT	H/W
	C8H	1 P1.3 external interrupt	P13INT	H/W
IRQ6	BEH	Timer A	TAINT	S/W
IRQ7	D4H	V-sync	VSYNC	S/W

NOTES:

- The interrupt level IRQ5 is not used in the S3F880A interrupt structure.
- For interrupt levels with two or more vectors, the lowest vector address usually has the highest priority. For example, C0H has higher priority (0) than C2H (1) within the level IRQ1. These priorities (see numbers) are hardwired.
- The interrupt names in the 'Identifier' column are used in this documentation to refer to specific interrupts, as distinguished from the interrupt source name or the pin at which an external interrupt request arrives.

Figure 5-2. S3C880A/F880A Interrupt Structure

INTERRUPT VECTOR ADDRESSES

Interrupt vector addresses for the S3C880A/F880A are stored in the first 256 bytes of the ROM. The reset address is 0100H. Vectors for all interrupt levels are stored in the vector address area (0H–FFH). Unused ROM in the range 00H–FFH can be used as program memory locations. You must be careful, however, not to overwrite interrupt vector addresses stored in this area.

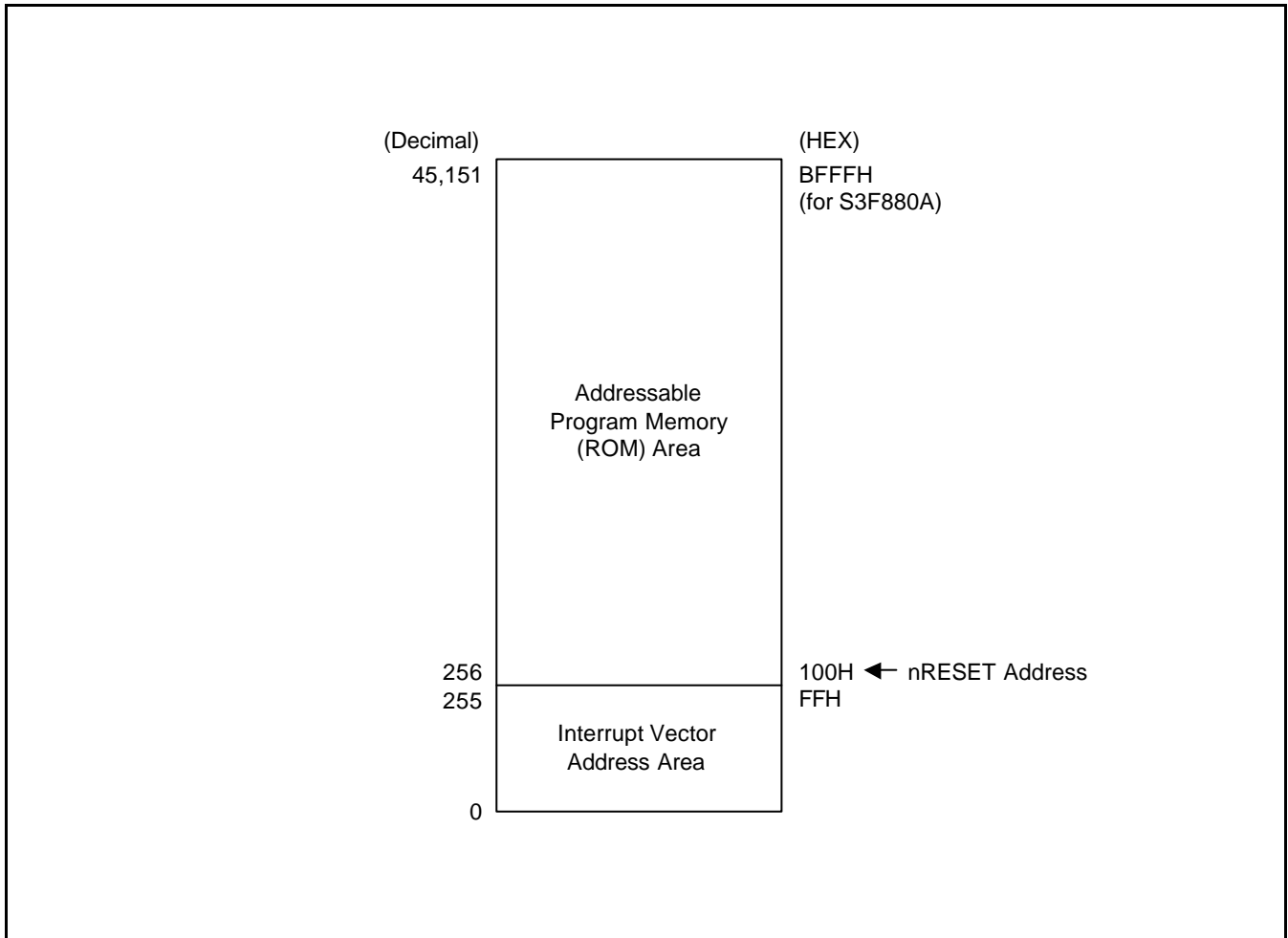


Figure 5-3. ROM Vector Address Area

Table 5-1. S3C880A/F880A Interrupt Vectors

Vector Address		Interrupt Source	Request		Reset/Clear	
Decimal Value	Hex Value		Interrupt Level	Priority in Level	H/W	S/W
252	FCH	Timer 0 (match)	IRQ0	–		√
212	D4H	V-sync	IRQ7	–		√
200	C8H	P1.3 external interrupt	IRQ4	1	√	
198	C6H	P1.2 external interrupt		0	√	
196	C4H	OSD ROW interrupt	IRQ2	–		√
194	C2H	P1.1 external interrupt	IRQ1	1	√	
192	C0H	P1.0 external interrupt		0	√	
190	BEH	Timer A	IRQ6	–		√
2	02H	Capture A (8-bit)	IRQ3	–	√	

NOTES:

1. Interrupt priorities are identified in inverse order: '0' is the highest priority, '1' is the next highest, and so on.
2. If two or more interrupts within the same level contend, the interrupt with the lowest vector address usually has priority over one with a higher vector address. (The priorities within a level are hardwired) For example, in the interrupt level IRQ1, the higher-priority interrupt vector is the P1.0 external interrupt, vector C0H; the lower-priority interrupt within that level is the P1.1 external interrupt, vector C2H.

ENABLE/DISABLE INTERRUPT INSTRUCTIONS (EI, DI)

The Enable Interrupts (EI) instruction globally enables the interrupt structure. All interrupts are serviced as they occur, and according to established priorities. The system initialization routine that is executed following a reset must always contain an EI instruction (assuming one or more interrupts are used in the application).

During the normal operation, you can execute the DI (Disable Interrupt) instruction at any time to globally disable interrupt processing. The EI and DI instructions change the value of bit 0 in the SYM register. Although you can manipulate SYM.0 directly to enable or disable interrupts, we recommend that you use the EI and DI instructions instead.

SYSTEM-LEVEL INTERRUPT CONTROL REGISTERS

In addition to the control registers for specific interrupt sources, four system-level control registers control interrupt processing:

- Each interrupt level is enabled or disabled (masked) by bit settings in the interrupt mask register (IMR).
- Relative priorities of interrupt levels are controlled by the interrupt priority register (IPR).
- The interrupt request register (IRQ) contains interrupt pending flags for each level.
- The system mode register (SYM) dynamically enables or disables global interrupt processing. SYM settings also enable fast interrupts and control external interface, if implemented.

Table 5-2. Interrupt Control Register Overview

Control Register	ID	R/W	Function Description
System mode register	SYM	R/W	Global interrupt processing enable and disable, fast interrupt processing.
Interrupt mask register	IMR	R/W	Bit settings in the IMR register enable and disable interrupt processing for each of the seven recognized interrupt levels, IRQ0–IRQ4, IRQ6, and IRQ7.
Interrupt priority register	IPR	R/W	Controls the relative processing priorities of the interrupt levels. For the S3C880A/F880A, the seven levels are organized into three groups: A, B, and C. Group A includes IRQ0 and IRQ1, group B is IRQ2, IRQ3, and IRQ4, and group C is IRQ6 and IRQ7.
Interrupt request register	IRQ	R	This register contains a request pending bit for each interrupt level.

INTERRUPT PROCESSING CONTROL POINTS

Interrupt processing can therefore be controlled in two ways: either globally, or by specific interrupt level and source. The system-level control points in the interrupt structure are therefore:

- Global interrupt enable and disable (by EI and DI instructions or by direct manipulation of SYM.0)
- Interrupt level enable and disable settings (IMR register)
- Interrupt level priority settings (IPR register)
- Interrupt source enable and disable settings in the corresponding peripheral control register(s)

NOTE

When writing an interrupt service routine, be sure that it properly manages the register pointer values (RP0 and RP1).

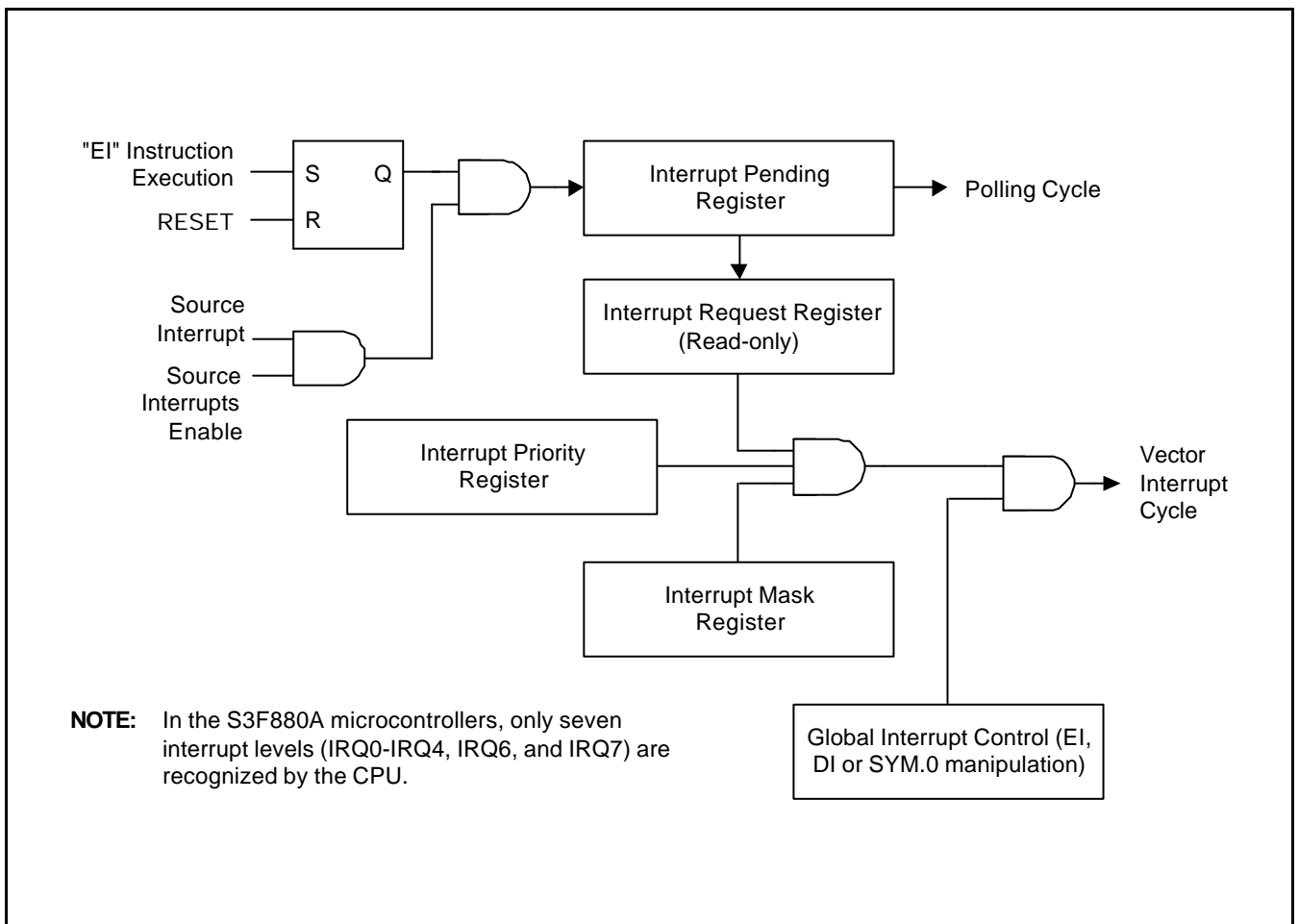


Figure 5-4. Interrupt Function Diagram

PERIPHERAL INTERRUPT CONTROL REGISTERS

For each interrupt source there is a corresponding peripheral control register (or registers) that controls the interrupts generated by the peripheral. These registers and their locations are listed in Table 5-3.

Table 5-3. Interrupt Source Control Registers

Interrupt Source	Interrupt Level	Control Register	Register Location
Timer 0 (match)	IRQ0	T0CON	Set 1, D2H
P1.0 external interrupt P1.1 external interrupt	IRQ1	P1CONL	Set 1, bank 0, E7H
OSD ROW interrupt	IRQ2	HTCON	Set 1, bank 1, E6H
Capture A (8-bit)	IRQ3	PWMCON	Set 1, bank 0, F8H
P1.2 external interrupt P1.3 external interrupt	IRQ4	P1CONL	Set 1, bank 0, E7H
Timer A	IRQ6	TACON	Set 1, bank 0, F2H
V-sync	IRQ7	HTCON	Set 1, bank 1, F6H

SYSTEM MODE REGISTER (SYM)

The system mode register, SYM (DEH, set 1), is used to enable and disable interrupt processing and control fast interrupt processing.

SYM.0 is the enable and disable bit for global interrupt processing. SYM.1–SYM.4 control fast interrupt processing: SYM.1 is the enable bit; SYM.2–SYM.4 are the fast interrupt level selection bits. SYM.7 is the enable bit for the tri-state external memory interface (not implemented in the S3C880A/F880A). A reset clears SYM.0, SYM.1, and SYM.7 to "0"; other bit values are undetermined.

The instructions EI and DI enable and disable global interrupt processing, respectively, by modifying the bit 0 value of the SYM register. An Enable Interrupt (EI) instruction must be included in the initialization routine, which follows a reset operation, in order to enable interrupt processing. Although you can manipulate SYM.0 directly to enable and disable interrupts during the normal operation, we recommend using the EI and DI instructions for this purpose.

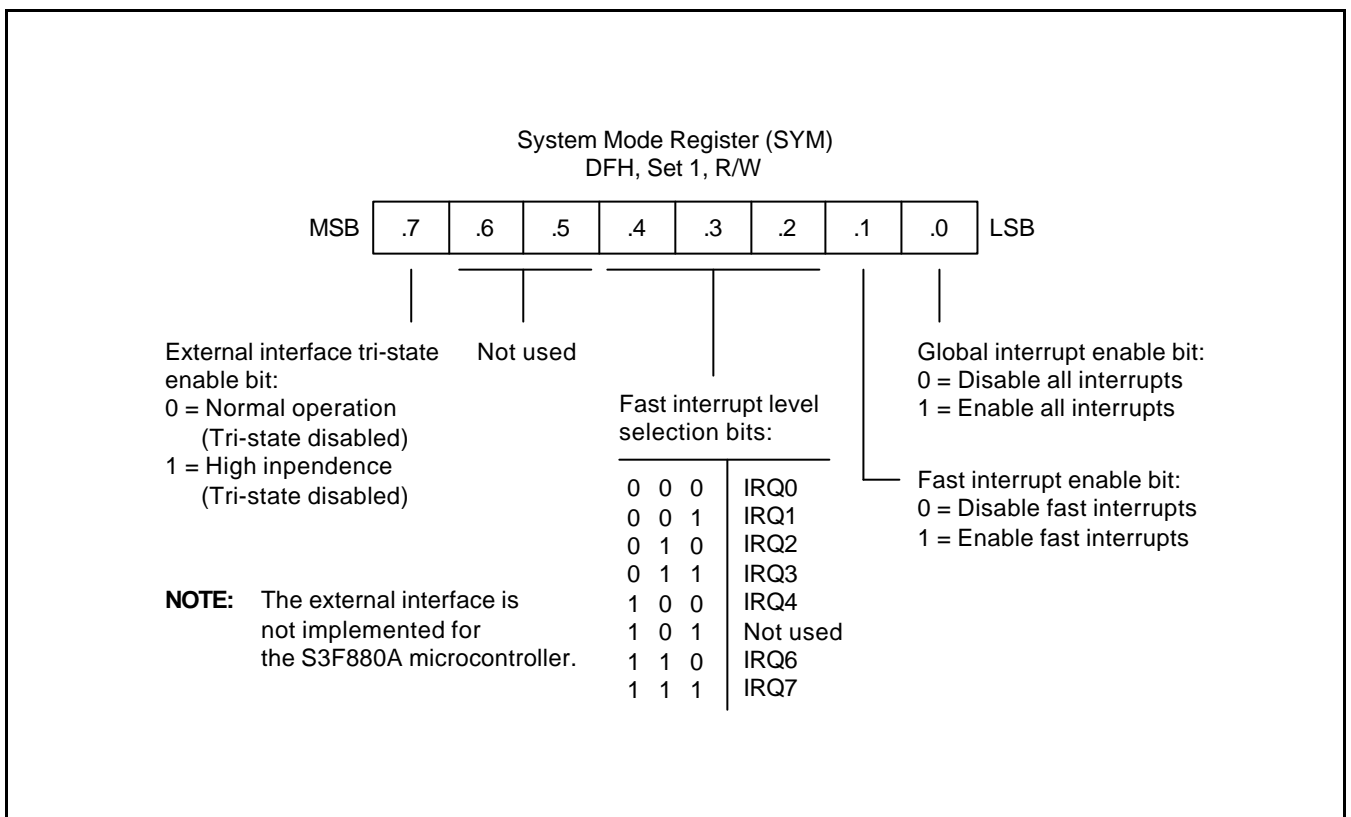


Figure 5-5. System Mode Register (SYM)

INTERRUPT MASK REGISTER (IMR)

The interrupt mask register (IMR) is used to enable or disable interrupt processing for each of the seven interrupt levels used in the S3C880A/F880A interrupt structure, IRQ0–IRQ4, IRQ6, and IRQ7. After a reset, all the IMR register values are undetermined.

Each IMR bit corresponds to a specific interrupt level: bit 1 to IRQ1, bit 2 to IRQ2, and so on. When the IMR bit of an interrupt level is cleared to "0", interrupt processing for that level is disabled (masked). When you set a level's IMR bit to "1", interrupt processing for the level is enabled (not masked).

The IMR register is mapped to the register location DDH in set 1. Bit values can be read and written by instructions using Register addressing mode.

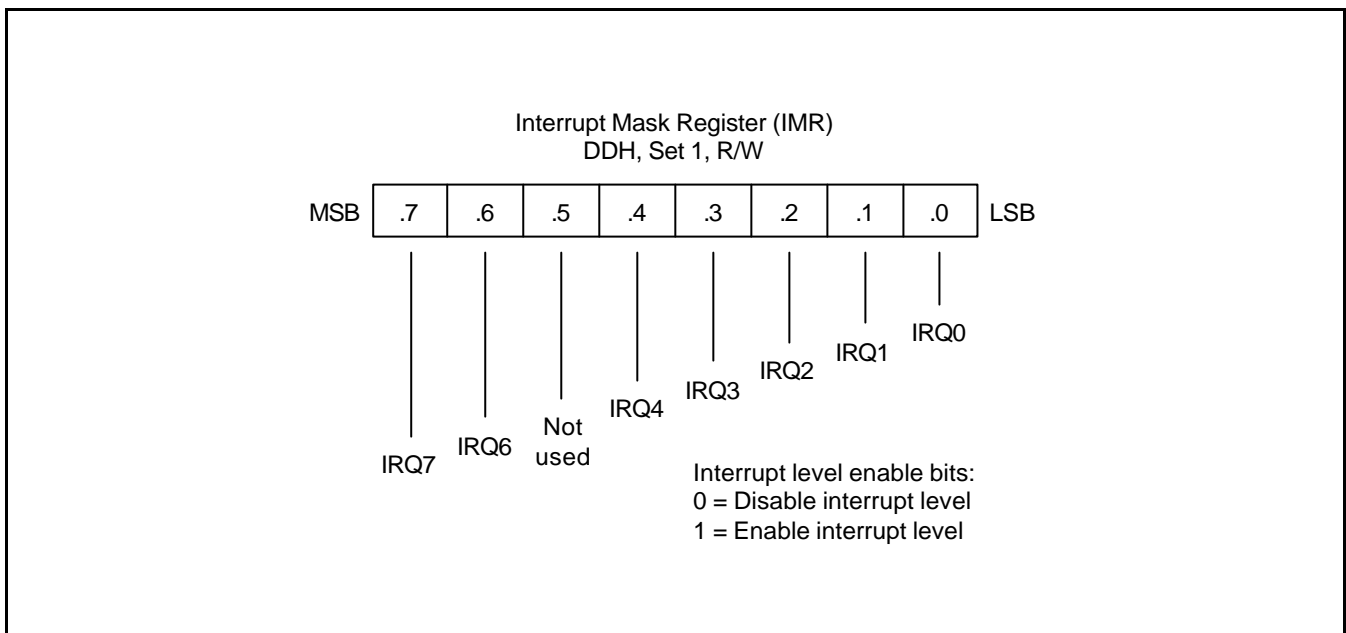


Figure 5-6. Interrupt Mask Register (IMR)

INTERRUPT PRIORITY REGISTER (IPR)

The interrupt priority register, IPR, is used to set the relative priorities of the seven interrupt levels used in the S3C880A/F880A interrupt structure. The IPR register is mapped to the register location FFH in set 1, bank 0. After a reset, the IPR register values are undetermined. If more than one interrupt source is active, the source with the highest priority level is serviced first. If both sources belong to the same interrupt level, the source with the lowest vector address usually has priority. (This priority is hardwired.)

In order to define the relative priorities of interrupt levels, they are organized into groups and subgroups by the interrupt logic. Three interrupt groups are defined for the IPR logic (see Figure 5-7). These groups and subgroups are used only for IPR register priority definitions:

- Group A IRQ0, IRQ1
- Group B IRQ2, IRQ3, and IRQ4
- Group C IRQ6, IRQ7

Bits 7, 4, and 1 of the IPR register control the relative priority of interrupt groups A, B, and C. For example, the setting '001B' would select the group relationship B > C > A, and '101B' would select C > B > A. The functions of other IPR bit settings are as follows:

- IPR.0 controls the relative priority setting of IRQ0 and IRQ1 interrupts.
- IPR.2 controls interrupt group B.
- Interrupt group B has a subgroup to provide an additional priority relationship among interrupt levels 2, 3, and 4. IPR.3 defines possible subgroup B relationship.
- IPR.6 controls the relative priorities of group C interrupts.

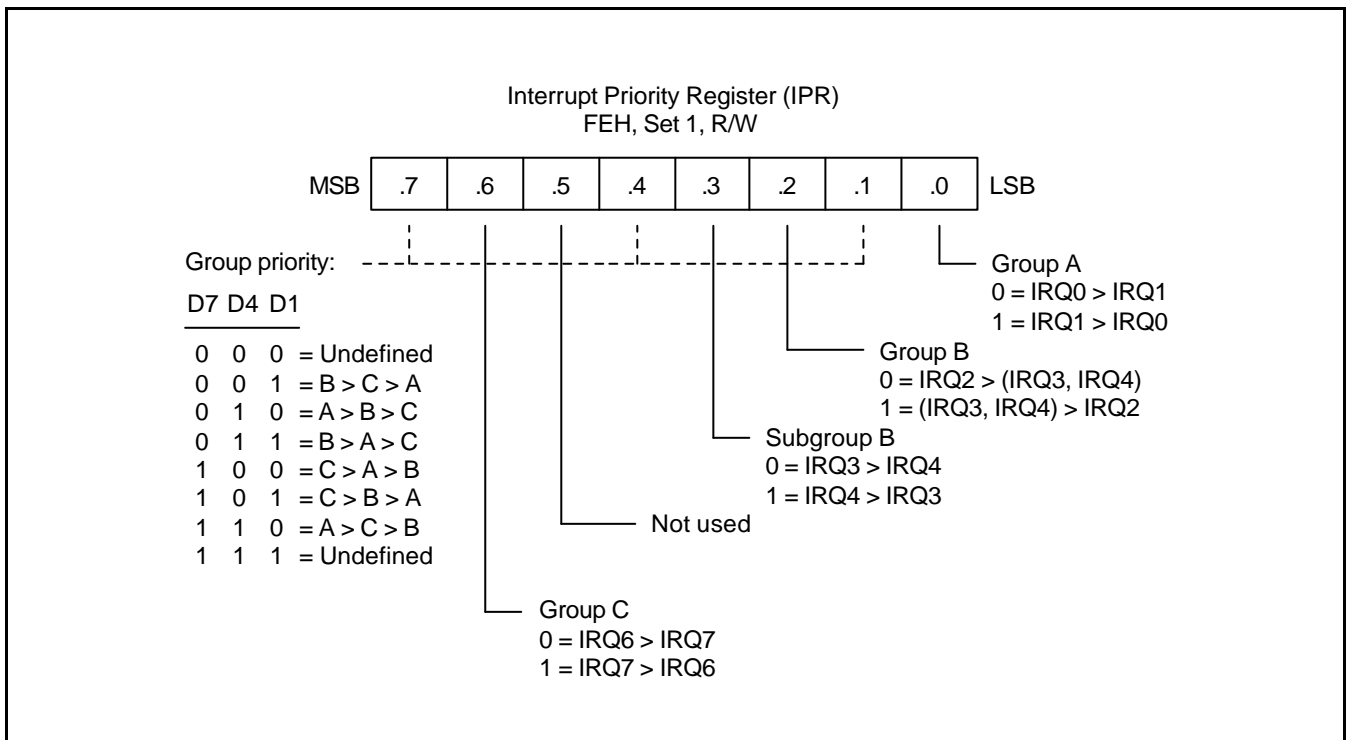


Figure 5-7. Interrupt Priority Register (IPR)

INTERRUPT PENDING FUNCTION TYPES

Overview

There are two types of interrupt pending bits: one is the type that automatically cleared by hardware after the interrupt service routine is acknowledged and executed; the other is the one that must be cleared by the application program's interrupt service routine.

Each interrupt level has a corresponding interrupt request bit in the IRQ register that the CPU polls for interrupt requests.

Pending Bits Cleared Automatically by Hardware

For interrupt pending bits that are cleared automatically by hardware, interrupt logic sets the corresponding pending bit to "1" when a request occurs. It then issues an IRQ pulse to tell the CPU that an interrupt is waiting to be serviced. The CPU acknowledges the interrupt source, executes the service routine, and clears the pending bit to "0". This type of pending bit is not mapped and cannot, therefore, be read or written by software.

In the S3C880A/F880A interrupt structure, the P1.0, P1.1, P1.2 and P1.3 external interrupts, and the capture A interrupt belong to this category of interrupts whose pending conditions are cleared automatically by hardware.

Pending Bits Cleared by the Service Routine

The second type of pending bit must be cleared by program software. The service routine must clear the appropriate pending bit before a return-from-interrupt subroutine (IRET) occurs. To do this, a "0" must be written to the pending bit location in the corresponding mode or control register.

Pending conditions for the timer 0 match interrupt, the timer A interrupt, the OSD row interrupt and the V-sync interrupt must be cleared by the application's service routines.

INTERRUPT SOURCE POLLING SEQUENCE

The interrupt request polling and servicing sequence is as follows:

1. A source generates an interrupt request by setting the interrupt request bit to "1".
2. The CPU polling procedure identifies a pending condition for that source.
3. The CPU checks the source's interrupt level.
4. The CPU generates an interrupt acknowledge signal.
5. Interrupt logic determines the interrupt's vector address.
6. The service routine starts and the source's pending flag is cleared to "0" (either by hardware or by software).
7. The CPU continues polling for interrupt requests.

INTERRUPT SERVICE ROUTINES

Before an interrupt request is serviced, the following conditions must be met:

- Interrupt processing must be enabled (EI, SYM.0 = "1")
- Interrupt level must be enabled (IMR register)
- Interrupt level must have the highest priority if more than one level is currently requesting service
- Interrupt must be enabled at the interrupt's source (peripheral control register)

If all the above conditions are met, the interrupt request is acknowledged at the end of the instruction cycle. The CPU then initiates an interrupt machine cycle that completes the following processing sequence:

1. Reset (clear to "0") the interrupt enable bit in the SYM register (SYM.0) to disable all subsequent interrupts.
2. Save the program counter and status flags to stack.
3. Branch to the interrupt vector to fetch the service routine's address.
4. Pass control to the interrupt service routine.

When the interrupt service routine is completed, an Interrupt Return instruction (IRET) occurs. The IRET restores the PC and status flags and sets SYM.0 to "1", allowing the CPU to process the next interrupt request.

GENERATING INTERRUPT VECTOR ADDRESSES

The interrupt vector area in the ROM contains the addresses of the interrupt service routine that corresponds to each level in the interrupt structure. Vectored interrupt processing follows this sequence:

1. Push the program counter's low-byte value to stack.
2. Push the program counter's high-byte value to stack.
3. Push the FLAGS register values to stack.
4. Fetch the service routine's high-byte address from the vector address.
5. Fetch the service routine's low-byte address from the vector address.
6. Branch to the service routine specified by the 16-bit vector address.

NOTE

A 16-bit vector address always begins at an even-numbered ROM location from 00H–FFH.

NESTING OF VECTORED INTERRUPTS

You can nest a higher priority interrupt request while a lower priority request is being serviced. To do this, you must follow these steps:

1. Push the current 8-bit interrupt mask register (IMR) value to the stack (PUSH IMR).
2. Load the IMR register with a new mask to enable the higher priority interrupt only.
3. Execute an EI instruction to enable interrupt processing (a higher priority interrupt will be processed if it occurs).
4. When the lower-priority interrupt service routine ends, return the IMR to its original value by restoring the previous mask from the stack (POP IMR).
5. Execute an IRET.

Depending on the application, you may be able to simplify this procedure to some extent.

INSTRUCTION POINTER (IP)

The instruction pointer (IP) is used by all the S3C8-series microcontrollers to control optional high-speed interrupt processing called *fast interrupts*. The IP consists of the register pair, DAH and DBH. The IP register names are IPH (high byte, IP15–IP8) and IPL (low byte, IP7–IP0).

FAST INTERRUPT PROCESSING

The feature called *fast interrupt processing* lets designated interrupts be completed in approximately six clock cycles instead of the usual 22 clock cycles. Bit 1 of the system mode register, SYM.1, enables fast interrupt processing while SYM.2–SYM.4 are used to select a specific level for fast processing.

Two other system registers support fast interrupts:

- The instruction pointer (IP) holds the starting address of the service routine (and is later used to swap the program counter values), and
- When a fast interrupt occurs, the contents of the FLAGS register is stored in an unmapped, dedicated register called FLAGS' (FLAGS prime).

NOTE

For the S3C880A/F880A microcontrollers, the service routine for any one of the seven interrupt levels (IRQ0–IRQ4, IRQ6, or IRQ7) can be designated as a fast interrupt.

Procedure for Initiating Fast Interrupts

To initiate fast interrupt processing, follow these steps:

1. Load the start address of the service routine into the instruction pointer.
2. Load the level number into the fast interrupt select field.
3. Write a "1" to the fast interrupt enable bit in the SYM register.

Fast Interrupt Service Routine

When an interrupt occurs in the level selected for fast interrupt processing, the following events occur:

1. The contents of the instruction pointer and the PC are swapped.
2. The FLAGS register values are written to the dedicated FLAGS' register.
3. The fast interrupt status bit in the FLAGS register is set.
4. The interrupt is serviced.
5. Assuming that the fast interrupt status bit is set, when the fast interrupt service routine ends, the instruction pointer and PC values are swapped back.
6. The content of FLAGS' (FLAGS prime) is copied automatically back into the FLAGS register.
7. The fast interrupt status bit in FLAGS is cleared automatically.

Programming Guidelines

Remember that the only way to enable or disable a fast interrupt is to set or clear the fast interrupt enable bit in the SYM register (SYM.1), respectively. Executing an EI or DI instruction affects only normal interrupt processing.

Also, if you use fast interrupts, remember to load the IP with a new start address when the fast interrupt service routine ends. (Please refer to the programming tip on page 5–17 for an example.)

 **PROGRAMMING TIP — Programming Level IRQ0 as a Fast Interrupt**

This example shows you how to program fast interrupt processing for a select interrupt level — in this case, for the timer 0 (capture) interrupt, INT0:

```

•
•
•
LD      T0CON,#52H          ; Enable T0 interrupt
                               ; Select fOSC/256 as T0 clock source

LDW     IPH,#T0_INT        ; IPH ← high byte of interrupt service routine
                               ; IPL ← low byte of interrupt service routine

LD      SYM,#02H           ; Enable fast interrupt processing
                               ; Select IRQ0 for fast service

EI                               ; Enable interrupts
•
•
•

FAST_RET:                       ; IP ← Address of T0_INT (again)
T0_INT:
•
•
•
(Fast service routine executes)
•
•
•
LD      T0CON,#52H          ; Clear T0INT interrupt pending bit
JP      T,FAST_RET

```

NOTES

6

SAM8 INSTRUCTION SET

OVERVIEW

The SAM8 instruction set is designed to support a large register file. It includes a full complement of 8-bit arithmetic and logic operations, including multiplying and dividing. There are 78 instructions. No special I/O instructions are necessary because I/O control and data registers are mapped directly into the register file. Decimal adjustment is included in binary-coded decimal (BCD) operations. 16-bit word data can be incremented and decremented. Flexible instructions for bit addressing, rotate, and shift operations complete the powerful data manipulation capabilities of the SAM8 instruction set.

DATA TYPES

The SAM8 CPU performs operations on bits, bytes, BCD digits, and two-byte words. Bits in the register file can be set, cleared, complemented, and tested. Bits within a byte are numbered from 7 to 0, where bit 0 is the least significant (right-most) bit.

REGISTER ADDRESSING

To access an individual register, an 8-bit address in the range 0–255 or the 4-bit address of a working register is specified. Paired registers can be used to construct 16-bit data or 16-bit program memory or data memory addresses. For detailed information about register addressing, please refer to Chapter 2, "Address Spaces."

ADDRESSING MODES

There are seven addressing modes: Register (R), Indirect Register (IR), Indexed (X), Direct (DA), Relative (RA), Immediate (IM), and Indirect (IA). For detailed descriptions of these addressing modes, please refer to chapter 3, "Addressing Modes."

Table 6-1. Instruction Group Summary

Mnemonic	Operands	Instruction
Load Instructions		
CLR	dst	Clear
LD	dst,src	Load
LDB	dst,src	Load bit
LDE	dst,src	Load external data memory
LDC	dst,src	Load program memory
LDED	dst,src	Load external data memory and decrement
LDCD	dst,src	Load program memory and decrement
LDEI	dst,src	Load external data memory and increment
LDCI	dst,src	Load program memory and increment
LDEPD	dst,src	Load external data memory with pre-decrement
LDCPD	dst,src	Load program memory with pre-decrement
LDEPI	dst,src	Load external data memory with pre-increment
LDCPI	dst,src	Load program memory with pre-increment
LDW	dst,src	Load word
POP	dst	Pop from stack
POPUD	dst,src	Pop user stack (decrementing)
POPUI	dst,src	Pop user stack (incrementing)
PUSH	src	Push to stack
PUSHUD	dst,src	Push user stack (decrementing)
PUSHUI	dst,src	Push user stack (incrementing)

Table 6-1. Instruction Group Summary (Continued)

Mnemonic	Operands	Instruction
Arithmetic Instructions		
ADC	dst,src	Add with carry
ADD	dst,src	Add
CP	dst,src	Compare
DA	dst	Decimal adjust
DEC	dst	Decrement
DECW	dst	Decrement word
DIV	dst,src	Divide
INC	dst	Increment
INCW	dst	Increment word
MULT	dst,src	Multiply
SBC	dst,src	Subtract with carry
SUB	dst,src	Subtract
Logic Instructions		
AND	dst,src	Logical AND
COM	dst	Complement
OR	dst,src	Logical OR
XOR	dst,src	Logical exclusive OR

Table 6-1. Instruction Group Summary (Continued)

Mnemonic	Operands	Instruction
Program Control Instructions		
BTJRF	dst,src	Bit test and jump relative on false
BTJRT	dst,src	Bit test and jump relative on true
CALL	dst	Call procedure
CPIJE	dst,src	Compare, increment and jump on equal
CPIJNE	dst,src	Compare, increment and jump on non-equal
DJNZ	r,dst	Decrement register and jump on non-zero
ENTER		Enter
EXIT		Exit
IRET		Interrupt return
JP	cc,dst	Jump on condition code
JP	dst	Jump unconditional
JR	cc,dst	Jump relative on condition code
NEXT		Next
RET		Return
WFI		Wait for interrupt
Bit Manipulation Instructions		
BAND	dst,src	Bit AND
BCP	dst,src	Bit compare
BITC	dst	Bit complement
BITR	dst	Bit reset
BITS	dst	Bit set
BOR	dst,src	Bit OR
BXOR	dst,src	Bit XOR
TCM	dst,src	Test complement under mask
TM	dst,src	Test under mask

Table 6-1. Instruction Group Summary (Concluded)

Mnemonic	Operands	Instruction
Rotate and Shift Instructions		
RL	dst	Rotate left
RLC	dst	Rotate left through carry
RR	dst	Rotate right
RRC	dst	Rotate right through carry
SRA	dst	Shift right arithmetic
SWAP	dst	Swap nibbles
CPU Control Instructions		
CCF		Complement carry flag
DI		Disable interrupts
EI		Enable interrupts
IDLE		Enter Idle mode
NOP		No operation
RCF		Reset carry flag
SB0		Set bank 0
SB1		Set bank 1
SCF		Set carry flag
SRP	src	Set register pointers
SRP0	src	Set register pointer 0
SRP1	src	Set register pointer 1
STOP		Enter Stop mode

FLAGS REGISTER (FLAGS)

The flags register FLAGS contains eight bits that describe the current status of the CPU operations. Four of these bits, FLAGS.4 – FLAGS.7, can be tested and used with conditional jump instructions; two others FLAGS.2 and FLAGS.3 are used for BCD arithmetic. The FLAGS register also contains a bit to indicate the status of fast interrupt processing (FLAGS.1) and a bank address status bit (FLAGS.0) to indicate whether bank 0 or bank 1 is being addressed.

FLAGS is located in the system control register area of set 1 (D5H). FLAGS register can be set or reset by instructions as long as its outcome does not affect the flags, such as, Load instruction. Logical and Arithmetic instructions such as, AND, OR, XOR, ADD, and SUB can affect the Flags register. For example, the AND instruction updates the Zero, Sign and Overflow flags based on the outcome of the AND instruction. If the AND instruction uses the Flags register as the destination, then simultaneously, two writes will occur to the Flags register, producing an unpredictable result.

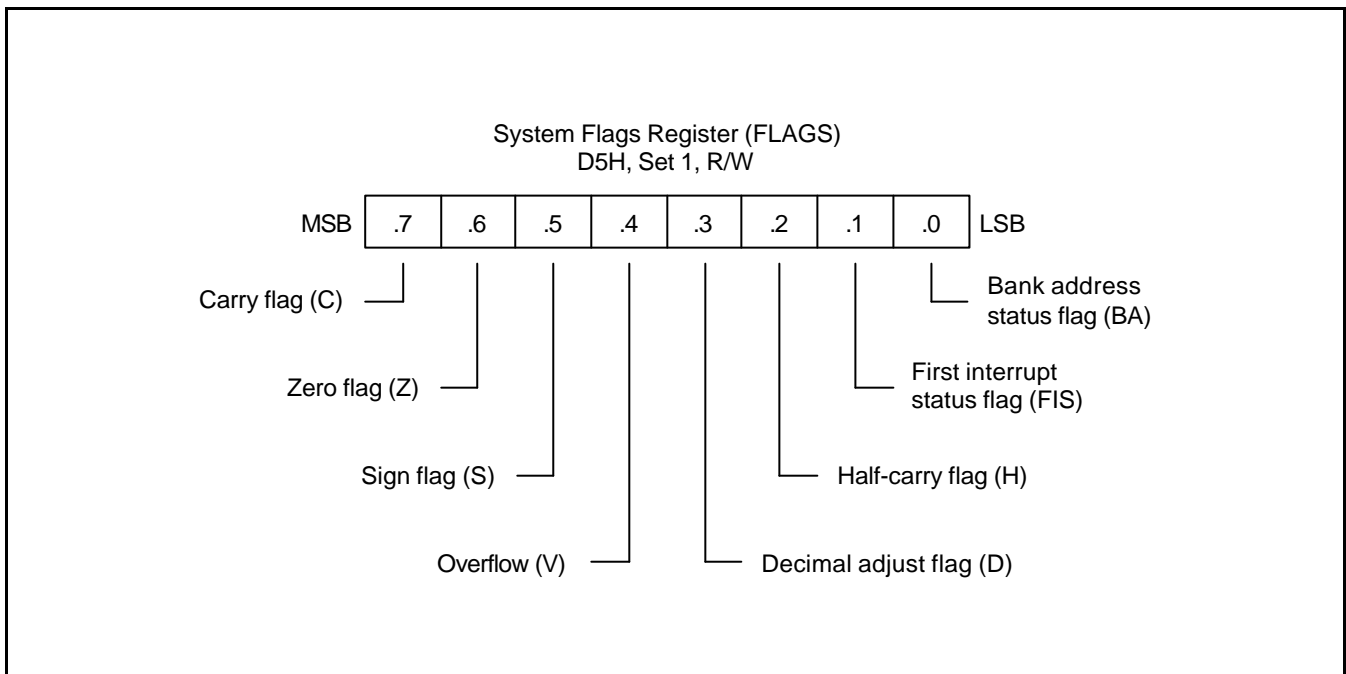


Figure 6-1. System Flags Register (FLAGS)

FLAG DESCRIPTIONS**C Carry Flag (FLAGS.7)**

The C flag is set to "1" if the result from an arithmetic operation generates a carry-out from or a borrow to the bit 7 position (MSB). After rotate and shift operations, it contains the last value shifted out of the specified register. Program instructions can set, clear, or complement the carry flag.

Z Zero Flag (FLAGS.6)

For arithmetic and logic operations, the Z flag is set to "1" if the result of the operation is zero. For operations that test register bits, and for shift and rotate operations, the Z flag is set to "1" if the result is logic zero.

S Sign Flag (FLAGS.5)

Following arithmetic, logic, rotate, or shift operations, the sign bit identifies the state of the MSB of the result. A logic zero indicates a positive number and a logic one indicates a negative number.

V Overflow Flag (FLAGS.4)

The V flag is set to "1" when the result of a two's-complement operation is greater than + 127 or less than – 128. It is also cleared to "0" following logic operations.

D Decimal Adjust Flag (FLAGS.3)

The DA bit is used to specify what type of instruction was executed last during BCD operations, so that a subsequent decimal adjust operation can execute correctly. The DA bit is not usually accessed by programmers, and cannot be used as a test condition.

H Half-Carry Flag (FLAGS.2)

The H bit is set to "1" whenever an addition generates a carry-out of bit 3, or when a subtraction borrows out of bit 4. It is used by the Decimal Adjust (DA) instruction to convert the binary result of a previous addition or subtraction into the correct decimal (BCD) result. The H flag is seldom accessed directly by a program.

FIS Fast Interrupt Status Flag (FLAGS.1)

The FIS bit is set during a fast interrupt cycle and reset during the IRET following interrupt servicing. When set, it inhibits all interrupts and causes the fast interrupt return to be executed when the IRET instruction is executed.

BA Bank Address Flag (FLAGS.0)

The BA flag indicates which register bank in the set 1 area of the internal register file is currently selected, bank 0 or bank 1. The BA flag is cleared to "0" (select bank 0) when you execute the SB0 instruction and is set to "1" (select bank 1) when you execute the SB1 instruction.

INSTRUCTION SET NOTATION

Table 6-2. Flag Notation Conventions

Flag	Description
C	Carry flag
Z	Zero flag
S	Sign flag
V	Overflow flag
D	Decimal-adjust flag
H	Half-carry flag
0	Cleared to logic zero
1	Set to logic one
*	Set or cleared according to operation
–	Value is unaffected
x	Value is undefined

Table 6-3. Instruction Set Symbols

Symbol	Description
dst	Destination operand
src	Source operand
@	Indirect register address prefix
PC	Program counter
IP	Instruction pointer
FLAGS	Flags register (D5H)
RP	Register pointer
#	Immediate operand or register address prefix
H	Hexadecimal number suffix
D	Decimal number suffix
B	Binary number suffix
opc	Opcode

Table 6-4. Instruction Notation Conventions

Notation	Description	Actual Operand Range
cc	Condition code	See list of condition codes in Table 6-6.
r	Working register only	Rn (n = 0–15)
rb	Bit (b) of working register	Rn.b (n = 0–15, b = 0–7)
r0	Bit 0 (LSB) of working register	Rn (n = 0–15)
rr	Working register pair	RRp (p = 0, 2, 4, ..., 14)
R	Register or working register	reg or Rn (reg = 0–255, n = 0–15)
Rb	Bit 'b' of register or working register	reg.b (reg = 0–255, b = 0–7)
RR	Register pair or working register pair	reg or RRp (reg = 0–254, even number only, where p = 0, 2, ..., 14)
IA	Indirect addressing mode	addr (addr = 0–254, even number only)
Ir	Indirect working register only	@Rn (n = 0–15)
IR	Indirect register or indirect working register	@Rn or @reg (reg = 0–255, n = 0–15)
Irr	Indirect working register pair only	@RRp (p = 0, 2, ..., 14)
IRR	Indirect register pair or indirect working register pair	@RRp or @reg (reg = 0–254, even only, where p = 0, 2, ..., 14)
X	Indexed addressing mode	#reg[Rn] (reg = 0–255, n = 0–15)
XS	Indexed (short offset) addressing mode	#addr[RRp] (addr = range –128 to +127, where p = 0, 2, ..., 14)
XL	Indexed (long offset) addressing mode	#addr [RRp] (addr = range 0–65535, where p = 0, 2, ..., 14)
DA	Direct addressing mode	addr (addr = range 0–65535)
RA	Relative addressing mode	addr (addr = number in the range +127 to –128 that is an offset relative to the address of the next instruction)
IM	Immediate addressing mode	#data (data = 0–255)
IML	Immediate (long) addressing mode	#data (data = range 0–65535)

Table 6-5. Opcode Quick Reference

OPCODE MAP									
LOWER NIBBLE (HEX)									
	—	0	1	2	3	4	5	6	7
U	0	DEC R1	DEC IR1	ADD r1,r2	ADD r1,lr2	ADD R2,R1	ADD IR2,R1	ADD R1,IM	BOR r0–Rb
	P	1	RLC R1	RLC IR1	ADC r1,r2	ADC r1,lr2	ADC R2,R1	ADC IR2,R1	ADC R1,IM
P		2	INC R1	INC IR1	SUB r1,r2	SUB r1,lr2	SUB R2,R1	SUB IR2,R1	SUB R1,IM
E	3	JP IRR1	SRP/0/1 IM	SBC r1,r2	SBC r1,lr2	SBC R2,R1	SBC IR2,R1	SBC R1,IM	BTJR r2.b, RA
N	5	POP R1	POP IR1	AND r1,r2	AND r1,lr2	AND R2,R1	AND IR2,R1	AND R1,IM	BITC r1.b
	I	6	COM R1	COM IR1	TCM r1,r2	TCM r1,lr2	TCM R2,R1	TCM IR2,R1	TCM R1,IM
B		7	PUSH R2	PUSH IR2	TM r1,r2	TM r1,lr2	TM R2,R1	TM IR2,R1	TM R1,IM
	B	8	DECW RR1	DECW IR1	PUSHUD IR1,R2	PUSHUI IR1,R2	MULT R2,RR1	MULT IR2,RR1	MULT IM,RR1
L		9	RL R1	RL IR1	POPUD IR2,R1	POPUI IR2,R1	DIV R2,RR1	DIV IR2,RR1	DIV IM,RR1
	E	A	INCW RR1	INCW IR1	CP r1,r2	CP r1,lr2	CP R2,R1	CP IR2,R1	CP R1,IM
H		B	CLR R1	CLR IR1	XOR r1,r2	XOR r1,lr2	XOR R2,R1	XOR IR2,R1	XOR R1,IM
	E	C	RRC R1	RRC IR1	CPIJE lr,r2,RA	LDC r1,lrr2	LDW RR2,RR1	LDW IR2,RR1	LDW RR1,IML
X		D	SRA R1	SRA IR1	CPIJNE lrr,r2,RA	LDC r2,lrr1	CALL IA1		LD IR1,IM
	E	E	RR R1	RR IR1	LDCD r1,lrr2	LDCI r1,lrr2	LD R2,R1	LD IR2,R1	LD R1,IM
X		F	SWAP R1	SWAP IR1	LDCPD r2,lrr1	LDCPI r2,lrr1	CALL IRR1	LD R2,IR1	CALL DA1

Table 6-5. Opcode Quick Reference (Continued)

OPCODE MAP									
LOWER NIBBLE (HEX)									
	—	8	9	A	B	C	D	E	F
U	0	LD r1,R2	LD r2,R1	DJNZ r1,RA	JR cc,RA	LD r1,IM	JP cc,DA	INC r1	NEXT
	P	1	↓	↓	↓	↓	↓	↓	ENTER
P	2								EXIT
	E	3							WFI
R	4								SB0
	5								SB1
N	6								IDLE
	I	7	↓	↓	↓	↓	↓	↓	STOP
B	8								DI
	B	9							EI
L	A								RET
	E	B							IRET
H	C								RCF
	D	↓	↓	↓	↓	↓	↓	↓	SCF
E	E								CCF
	X	F	LD r1,R2	LD r2,R1	DJNZ r1,RA	JR cc,RA	LD r1,IM	JP cc,DA	INC r1

CONDITION CODES

The opcode of a conditional jump always contains a 4-bit field called the condition code (cc). This specifies under which conditions it is to execute the jump. For example, a conditional jump with the condition code for "equal" after a compare operation only jumps if the two operands are equal. Condition codes are listed in Table 6-6.

The carry (C), zero (Z), sign (S), and overflow (V) flags are used to control the operation of conditional jump instructions.

Table 6-6. Condition Codes

Binary	Mnemonic	Description	Flags Set
0000	F	Always false	—
1000	T	Always true	—
0111 ⁽¹⁾	C	Carry	C = 1
1111 ⁽¹⁾	NC	No carry	C = 0
0110 ⁽¹⁾	Z	Zero	Z = 1
1110 ⁽¹⁾	NZ	Not zero	Z = 0
1101	PL	Plus	S = 0
0101	MI	Minus	S = 1
0100	OV	Overflow	V = 1
1100	NOV	No overflow	V = 0
0110 ⁽¹⁾	EQ	Equal	Z = 1
1110 ⁽¹⁾	NE	Not equal	Z = 0
1001	GE	Greater than or equal	(S XOR V) = 0
0001	LT	Less than	(S XOR V) = 1
1010	GT	Greater than	(Z OR (S XOR V)) = 0
0010	LE	Less than or equal	(Z OR (S XOR V)) = 1
1111 ⁽¹⁾	UGE	Unsigned greater than or equal	C = 0
0111 ⁽¹⁾	ULT	Unsigned less than	C = 1
1011	UGT	Unsigned greater than	(C = 0 AND Z = 0) = 1
0011	ULE	Unsigned less than or equal	(C OR Z) = 1

NOTES:

1. It indicates condition codes that are related to two different mnemonics but which test the same flag. For example, Z and EQ are both true if the zero flag (Z) is set, but after an ADD instruction, Z would probably be used; after a CP instruction, however, EQ would probably be used.
2. For operations involving unsigned numbers, the special condition codes UGE, ULT, UGT, and ULE must be used.

INSTRUCTION DESCRIPTIONS

This chapter contains detailed information and programming examples for each instruction in the SAM8 instruction set. Information is arranged in a consistent format for improved readability and fast referencing. The following information is included in each instruction description:

- Instruction name (mnemonic)
- Full instruction name
- Source/destination format of the instruction operand
- Shorthand notation of the instruction's operation
- Textual description of the instruction's effect
- Specific flag settings affected by the instruction
- Detailed description of the instruction's format, execution time, and addressing mode(s)
- Programming example(s) explaining how to use the instruction

ADC — Add with Carry

ADC dst,src

Operation: $dst \leftarrow dst + src + c$

The source operand, along with the setting of the carry flag, is added to the destination operand and the sum is stored in the destination. The contents of the source are unaffected. Two's-complement addition is performed. In multiple precision arithmetic, this instruction permits the carry from the addition of low-order operands to be carried into the addition of high-order operands.

Flags:

- C:** Set if there is a carry from the most significant bit of the result; cleared otherwise.
- Z:** Set if the result is "0"; cleared otherwise.
- S:** Set if the result is negative; cleared otherwise.
- V:** Set if arithmetic overflow occurs, that is, if both operands are of the same sign and the result is of the opposite sign; cleared otherwise.
- D:** Always cleared to "0".
- H:** Set if there is a carry from the most significant bit of the low-order four bits of the result; cleared otherwise.

Format:

		Bytes	Cycles	Opcode (Hex)	Addr Mode <u>dst</u>	<u>src</u>			
<table border="1" style="display: inline-table; vertical-align: middle;"> <tr> <td style="padding: 2px 10px;">opc</td> <td style="padding: 2px 10px;">dst src</td> </tr> </table>	opc	dst src		2	6	12	r	r	
	opc	dst src							
				13	r	lr			
<table border="1" style="display: inline-table; vertical-align: middle;"> <tr> <td style="padding: 2px 10px;">opc</td> <td style="padding: 2px 10px;">src</td> <td style="padding: 2px 10px;">dst</td> </tr> </table>	opc	src	dst		3	10	14	R	R
	opc	src	dst						
				15	R	IR			
<table border="1" style="display: inline-table; vertical-align: middle;"> <tr> <td style="padding: 2px 10px;">opc</td> <td style="padding: 2px 10px;">dst</td> <td style="padding: 2px 10px;">src</td> </tr> </table>	opc	dst	src		3	10	16	R	IM
opc	dst	src							

Examples: Given: R1 = 10H, R2 = 03H, C flag = "1", register 01H = 20H, register 02H = 03H, and register 03H = 0AH:

```

ADC   R1,R2   →   R1 = 14H, R2 = 03H
ADC   R1,@R2  →   R1 = 1BH, R2 = 03H
ADC   01H,02H →   Register 01H = 24H, register 02H = 03H
ADC   01H,@02H →   Register 01H = 2BH, register 02H = 03H
ADC   01H,#11H →   Register 01H = 32H

```

In the first example, the destination register R1 contains the value 10H, the carry flag is set to "1", and the source working register R2 contains the value 03H. The statement "ADC R1,R2" adds 03H and the carry flag value ("1") to the destination value 10H, leaving 14H in the register R1.

ADD — Add

ADD dst,src

Operation: dst ← dst + src

The source operand is added to the destination operand and the sum is stored in the destination. The contents of the source are unaffected. Two's-complement addition is performed.

Flags:

- C:** Set if there is a carry from the most significant bit of the result; cleared otherwise.
- Z:** Set if the result is "0"; cleared otherwise.
- S:** Set if the result is negative; cleared otherwise.
- V:** Set if arithmetic overflow occurred, that is, if both operands are of the same sign and the result is of the opposite sign; cleared otherwise.
- D:** Always cleared to "0".
- H:** Set if a carry from the low-order nibble occurred.

Format:

		Bytes	Cycles	Opcode (Hex)	Addr <u>dst</u>	Mode <u>src</u>
opc	dst src	2	6	02	r	r
				03	r	lr
opc	src	3	10	04	R	R
				05	R	IR
opc	dst	3	10	06	R	IM

Examples: Given: R1 = 12H, R2 = 03H, register 01H = 21H, register 02H = 03H, register 03H = 0AH:

```

ADD    R1,R2    →    R1 = 15H, R2 = 03H
ADD    R1,@R2   →    R1 = 1CH, R2 = 03H
ADD    01H,02H  →    Register 01H = 24H, register 02H = 03H
ADD    01H,@02H →    Register 01H = 2BH, register 02H = 03H
ADD    01H,#25H →    Register 01H = 46H
    
```

In the first example, the destination working register R1 contains 12H and the source working register R2 contains 03H. The statement "ADD R1,R2" adds 03H to 12H, leaving the value 15H in the register R1.

AND — Logical AND

AND dst,src

Operation: dst ← dst AND src

The source operand is logically ANDed with the destination operand. The result is stored in the destination. The AND operation results in a "1" bit being stored whenever the corresponding bits in the two operands are both logic ones; otherwise a "0" bit value is stored. The contents of the source are unaffected.

Flags: **C:** Unaffected.
Z: Set if the result is "0"; cleared otherwise.
S: Set if the result bit 7 is set; cleared otherwise.
V: Always cleared to "0".
D: Unaffected.
H: Unaffected.

Format:

		Bytes	Cycles	Opcode (Hex)	Addr <u>dst</u>	Mode <u>src</u>
opc	dst src	2	6	52	r	r
				53	r	lr
opc	src	3	10	54	R	R
				55	R	IR
opc	dst	3	10	56	R	IM

Examples: Given: R1 = 12H, R2 = 03H, register 01H = 21H, register 02H = 03H, register 03H = 0AH:

AND R1,R2 → R1 = 02H, R2 = 03H
AND R1,@R2 → R1 = 02H, R2 = 03H
AND 01H,02H → Register 01H = 01H, register 02H = 03H
AND 01H,@02H → Register 01H = 00H, register 02H = 03H
AND 01H,#25H → Register 01H = 21H

In the first example, the destination working register R1 contains the value 12H and the source working register R2 contains 03H. The statement "AND R1,R2" logically ANDs the source operand 03H with the destination operand value 12H, leaving the value 02H in the register R1.

BAND – Bit AND

BAND dst,src.b

BAND dst.b,src

Operation: $dst(0) \leftarrow dst(0) \text{ AND } src(b)$
 or
 $dst(b) \leftarrow dst(b) \text{ AND } src(0)$

The specified bit of the source (or the destination) is logically ANDed with the zero bit (LSB) of the destination (or source). The resultant bit is stored in the specified bit of the destination. No other bits of the destination are affected. The source is unaffected.

Flags: **C:** Unaffected.
Z: Set if the result is "0"; cleared otherwise.
S: Cleared to "0".
V: Undefined.
D: Unaffected.
H: Unaffected.

Format:

			Bytes	Cycles	Opcode (Hex)	Addr Mode <u>dst</u> <u>src</u>
opc	dst b 0	src	3	10	67	r0 Rb
opc	src b 1	dst	3	10	67	Rb r0

NOTE: In the second byte of the 3-byte instruction formats, the destination (or source) address is four bits, the bit address 'b' is three bits, and the LSB address value is one bit in length.

Examples: Given: R1 = 07H and register 01H = 05H:

BAND R1,01H.1 → R1 = 05H, register 01H = 05H

BAND 01H.1,R1 → Register 01H = 05H, R1 = 07H

In the first example, the source register 01H contains the value 05H (00000101B) and the destination working register R1 contains 07H (00000111B). The statement "BAND R1,01H.1" ANDs the bit 1 value of the source register ("0") with the bit 0 value of the register R1 (destination), leaving the value 0525H (00000101B) in the register R1.

BCP – Bit Compare

BCP dst,src.b

Operation: dst(0) – src(b)

The specified bit of the source is compared to (subtracted from) bit zero (LSB) of the destination. The zero flag is set if the bits are the same; otherwise it is cleared. The contents of both operands are unaffected by the comparison.

Flags:
C: Unaffected.
Z: Set if the two bits are the same; cleared otherwise.
S: Cleared to "0".
V: Undefined.
D: Unaffected.
H: Unaffected.

Format:

			Bytes	Cycles	Opcode (Hex)	Addr Mode <u>dst</u> <u>src</u>
opc	dst b 0	src	3	10	17	r0 Rb

NOTE: In the second byte of the instruction format, the destination address is four bits, the bit address 'b' is three bits, and the LSB address value is one bit in length.

Example: Given: R1 = 07H and register 01H = 01H:

BCP R1,01H.1 → R1 = 07H, register 01H = 01H

If the destination working register R1 contains the value 07H (00000111B) and the source register 01H contains the value 01H (00000001B), the statement "BCP R1,01H.1" compares bit one of the source register (01H) and bit zero of the destination register (R1). Because the bit values are not identical, the zero flag bit (Z) is cleared in the FLAGS register (0D5H).

BITC – Bit Complement

BITC dst.b

Operation: dst(b) ← NOT dst(b)

This instruction complements the specified bit within the destination without affecting any other bit in the destination.

Flags: **C:** Unaffected.
Z: Set if the result is "0"; cleared otherwise.
S: Cleared to "0".
V: Undefined.
D: Unaffected.
H: Unaffected.

Format:

		Bytes	Cycles	Opcode (Hex)	Addr Mode <u>dst</u>
opc	dst b 0	2	8	57	rb

NOTE: In the second byte of the instruction format, the destination address is four bits, the bit address 'b' is three bits, and the LSB address value is one bit in length.

Example: Given: R1 = 07H

BITC R1.1 → R1 = 05H

If the working register R1 contains the value 07H (00000111B), the statement "BITC R1.1" complements bit one of the destination, leaving the value 05H (00000101B) in the register R1. Because the result of the complement is not "0", the zero flag (Z) in the FLAGS register (0D5H) is cleared.

BITR – Bit Reset

BITR dst.b

Operation: dst(b) ← 0

The BITR instruction clears the specified bit within the destination without affecting any other bit in the destination.

Flags: No flags are affected.

Format:

		Bytes	Cycles	Opcode (Hex)	Addr Mode <u>dst</u>
opc	dst b 0	2	8	77	rb

NOTE: In the second byte of the instruction format, the destination address is four bits, the bit address 'b' is three bits, and the LSB address value is one bit in length.

Example: Given: R1 = 07H:

BITR R1.1 → R1 = 05H

If the value of the working register R1 is 07H (00000111B), the statement "BITR R1.1" clears bit one of the destination register R1, leaving the value 05H (00000101B).

BITS – Bit Set

BITS dst.b

Operation: $\text{dst}(b) \leftarrow 1$

The BITS instruction sets the specified bit within the destination without affecting any other bit in the destination.

Flags: No flags are affected.

Format:

		Bytes	Cycles	Opcode (Hex)	Addr Mode <u>dst</u>
opc	dst b 1	2	8	77	rb

NOTE: In the second byte of the instruction format, the destination address is four bits, the bit address 'b' is three bits, and the LSB address value is one bit in length.

Example: Given: R1 = 07H:

BITS R1.3 → R1 = 0FH

If the working register R1 contains the value 07H (00000111B), the statement "BITS R1.3" sets bit three of the destination register R1 to "1", leaving the value 0FH (00001111B).

BOR – Bit OR

BOR dst,src,b

BOR dst,b,src

Operation: $dst(0) \leftarrow dst(0) \text{ OR } src(b)$

or

$dst(b) \leftarrow dst(b) \text{ OR } src(0)$

The specified bit of the source (or destination) is logically ORed with bit zero (LSB) of the destination (or source). The resulting bit value is stored in the specified bit of the destination. No other bits of the destination are affected. The source is unaffected.

Flags:

- C:** Unaffected.
- Z:** Set if the result is "0"; cleared otherwise.
- S:** Cleared to "0".
- V:** Undefined.
- D:** Unaffected.
- H:** Unaffected.

Format:

			Bytes	Cycles	Opcode (Hex)	Addr Mode <u>dst</u> <u>src</u>
opc	dst b 0	src	3	10	07	r0 Rb
opc	src b 1	dst	3	10	07	Rb r0

NOTE: In the second byte of the 3-byte instruction formats, the destination (or source) address is four bits, the bit address 'b' is three bits, and the LSB address value is one bit.

Examples: Given: R1 = 07H and register 01H = 03H:

BOR R1, 01H.1 → R1 = 07H, register 01H = 03H

BOR 01H.2, R1 → Register 01H = 07H, R1 = 07H

In the first example, the destination working register R1 contains the value 07H (00000111B) and the source register 01H the value 03H (00000011B). The statement "BOR R1,01H.1" logically ORs bit one of the register 01H (source) with bit zero of R1 (destination). This leaves the same value (07H) in the working register R1.

In the second example, the destination register 01H contains the value 03H (00000011B) and the source working register R1 the value 07H (00000111B). The statement "BOR 01H.2,R1" logically ORs bit two of the register 01H (destination) with bit zero of R1 (source). This leaves the value 07H in the register 01H.

BTJRF – Bit Test, Jump Relative on False

BTJRF dst,src.b

Operation: If src(b) is a "0", then $PC \leftarrow PC + dst$
 The specified bit within the source operand is tested. If it is a "0", the relative address is added to the program counter and control passes to the statement whose address is now in the PC; otherwise, the instruction following the BTJRF instruction is executed.

Flags: No flags are affected.

Format:

(1)			Bytes	Cycles	Opcode (Hex)	Addr Mode
opc	src b 0	dst				<u>dst</u> <u>src</u>
3			3	16/18 (2)	37	RA rb

NOTES:

1. In the second byte of the instruction format, the source address is four bits, the bit address 'b' is three bits, and the LSB address value is one bit in length.
2. Execution time is 18 cycles if the jump is taken or 16 cycles if it is not taken.

Example: Given: R1 = 07H:

BTJRF SKIP,R1.3 → PC jumps to SKIP location

If the working register R1 contains the value 07H (00000111B), the statement "BTJRF SKIP,R1.3" tests bit 3. Because it is "0", the relative address is added to the PC and the PC jumps to the memory location pointed to by the SKIP. (Remember that the memory location must be within the allowed range of + 127 to - 128.)



BTJRT – Bit Test, Jump Relative on True

BTJRT dst,src.b

Operation: If src(b) is a "1", then $PC \leftarrow PC + dst$

The specified bit within the source operand is tested. If it is a "1", the relative address is added to the program counter and control passes to the statement whose address is now in the PC; otherwise, the instruction following the BTJRT instruction is executed.

Flags: No flags are affected.

Format:

(1)			Bytes	Cycles	Opcode (Hex)	Addr Mode <u>dst</u> <u>src</u>
opc	src b 1	dst	3	16/18 (2)	37	RA rb

NOTES:

1. In the second byte of the instruction format, the source address is four bits, the bit address 'b' is three bits, and the LSB address value is one bit in length.
2. Execution time is 18 cycles if the jump is taken or 16 cycles if it is not taken.

Example: Given: R1 = 07H:

BTJRT SKIP,R1.1

If the working register R1 contains the value 07H (00000111B), the statement "BTJRT SKIP,R1.1" tests bit one in the source register (R1). Because it is a "1", the relative address is added to the PC and the PC jumps to the memory location pointed to by the SKIP. (Remember that the memory location must be within the allowed range of + 127 to - 128.)

BXOR – Bit XOR

BXOR dst,src,b

BXOR dst,b,src

Operation: $dst(0) \leftarrow dst(0) \text{ XOR } src(b)$
 or
 $dst(b) \leftarrow dst(b) \text{ XOR } src(0)$

The specified bit of the source (or destination) is logically exclusive-ORed with bit zero (LSB) of the destination (or source). The result bit is stored in the specified bit of the destination. No other bits of the destination are affected. The source is unaffected.

Flags:
C: Unaffected.
Z: Set if the result is "0"; cleared otherwise.
S: Cleared to "0".
V: Undefined.
D: Unaffected.
H: Unaffected.

Format:

			Bytes	Cycles	Opcode (Hex)	Addr Mode <u>dst</u> <u>src</u>
opc	dst b 0	src	3	10	27	r0 Rb
opc	src b 1	dst	3	10	27	Rb r0

NOTE: In the second byte of the 3-byte instruction format, the destination (or source) address is four bits, the bit address 'b' is three bits, and the LSB address value is one bit in length.

Examples: Given: R1 = 07H (00000111B) and register 01H = 03H (00000011B):

BXOR R1,01H.1 → R1 = 05H, register 01H = 03H

BXOR 01H.2,R1 → Register 01H = 07H, R1 = 07H

In the first example, the destination working register R1 has the value 07H (00000111B) and the source register 01H has the value 03H (00000011B). The statement "BXOR R1,01H.1" exclusive-ORs bit one of the register 01H (source) with bit zero of R1 (destination). The result bit value is stored in bit zero of R1, changing its value from 07H to 05H. The value of the source register 01H is unaffected.



CALL – Call Procedure

CALL dst

Operation: SP ← SP – 1
 @SP ← PCL
 SP ← SP –1
 @SP ← PCH
 PC ← dst

The current contents of the program counter are pushed onto the top of the stack. The program counter value used is the address of the first instruction following the CALL instruction. The specified destination address is then loaded into the program counter and points to the first instruction of a procedure. At the end of the procedure the return instruction (RET) can be used to return to the original program flow. RET pops the top of the stack back into the program counter.

Flags: No flags are affected.

Format:

		Bytes	Cycles	Opcode (Hex)	Addr Mode <u>dst</u>
opc	dst	3	18	F6	DA
opc	dst	2	18	F4	IRR
opc	dst	2	20	D4	IA

Examples: Given: R0 = 35H, R1 = 21H, PC = 1A47H, and SP = 0002H:

CALL 3521H → SP = 0000H

(Memory locations 0000H = 1AH, 0001H = 4AH, where
 4AH is the address that follows the instruction.)

CALL @RR0 → SP = 0000H (0000H = 1AH, 0001H = 49H)

CALL #40H → SP = 0000H (0000H = 1AH, 0001H = 49H)

In the first example, if the program counter value is 1A47H and the stack pointer contains the value 0002H, the statement "CALL 3521H" pushes the current PC value onto the top of the stack. The stack pointer now points to the memory location 0000H. The PC is then loaded with the value 3521H, the address of the first instruction in the program sequence to be executed.

If the contents of the program counter and stack pointer are the same as in the first example, the statement "CALL @RR0" produces the same result except that 49H is stored in stack location 0001H (because the two-byte instruction format was used). The PC is then loaded with the value 3521H, the address of the first instruction in the program sequence to be executed. Assuming that the contents of the program counter and stack pointer are the same as in the first example, if the program address 0040H contains 35H and the program address 0041H contains 21H, the statement "CALL #40H" produces the same result as in the second example.

CCF – Complement Carry Flag

CCF

Operation: $C \leftarrow \text{NOT } C$

The carry flag (C) is complemented. If C = "1", the value of the carry flag is changed to logic zero; if C = "0", the value of the carry flag is changed to logic one.

Flags: C: Complemented.

No other flags are affected.

Format:

	Bytes	Cycles	Opcode (Hex)
opc	1	6	EF

Example: Given: The carry flag = "0":

CCF

If the carry flag = "0", the CCF instruction complements it in the FLAGS register (0D5H), changing its value from logic zero to logic one.

CLR – Clear

CLR dst

Operation: dst ← dst XOR dst
 The destination location is cleared to "0".

Flags: No flags are affected.

Format:

		Bytes	Cycles	Opcode (Hex)	Addr Mode <u>dst</u>
opc	dst	2	6	B0	R
				B1	IR

Examples: Given: Register 00H = 4FH, register 01H = 02H, and register 02H = 5EH:

CLR 00H → Register 00H = 00H

CLR @01H → Register 01H = 02H, register 02H = 00H

In Register (R) addressing mode, the statement "CLR 00H" clears the destination register 00H value to 00H. In the second example, the statement "CLR @01H" uses Indirect Register (IR) addressing mode to clear the 02H register value to 00H.

COM – Complement

COM dst

Operation: dst ← NOT dst

The contents of the destination location are complemented (one's complement); all "1s" are changed to "0s", and vice-versa.

Flags: **C:** Unaffected.
Z: Set if the result is "0"; cleared otherwise.
S: Set if the result bit 7 is set; cleared otherwise.
V: Always reset to "0".
D: Unaffected.
H: Unaffected.

Format:

		Bytes	Cycles	Opcode (Hex)	Addr Mode <u>dst</u>
opc	dst	2	6	60	R
				61	IR

Examples: Given: R1 = 07H and register 07H = 0F1H:

COM R1 → R1 = 0F8H

COM @R1 → R1 = 07H, register 07H = 0EH

In the first example, the destination working register R1 contains the value 07H (00000111B). The statement "COM R1" complements all the bits in R1: all logic ones are changed to logic zeros, and vice-versa, leaving the value 0F8H (11111000B).

In the second example, Indirect Register (IR) addressing mode is used to complement the value of the destination register 07H (11110001B), leaving the new value 0EH (00001110B).

CP – Compare

CP dst,src

Operation: dst – src

The source operand is compared to (subtracted from) the destination operand, and the appropriate flags are set accordingly. The contents of both operands are unaffected by the comparison.

Flags:

- C:** Set if a "borrow" occurred (src > dst); cleared otherwise.
- Z:** Set if the result is "0"; cleared otherwise.
- S:** Set if the result is negative; cleared otherwise.
- V:** Set if arithmetic overflow occurred; cleared otherwise.
- D:** Unaffected.
- H:** Unaffected.

Format:

			Bytes	Cycles	Opcode (Hex)	Addr Mode <u>dst</u> <u>src</u>
opc	dst src		2	6	A2 A3	r r r lr
opc	src	dst	3	10	A4 A5	R R R IR
opc	dst	src	3	10	A6	R IM

Examples: 1. Given: R1 = 02H and R2 = 03H:

CP R1,R2 → Set the C and S flags

The destination working register R1 contains the value 02H and the source register R2 contains the value 03H. The statement "CP R1,R2" subtracts the R2 value (source/subtrahend) from the R1 value (destination/minuend). Because a "borrow" occurs and the difference is negative, C and S are "1".

2. Given: R1 = 05H and R2 = 0AH:

```

CP      R1,R2
JP      UGE,SKIP
INC     R1
SKIP    LD      R3,R1

```

In this example, the destination working register R1 contains the value 05H which is less than the contents of the source working register R2 (0AH). The statement "CP R1,R2" generates C = "1" and the JP instruction does not jump to the SKIP location. After the statement "LD R3,R1" executes, the value 06H remains in the working register R3.

CPIJE – Compare, Increment, and Jump on Equal

CPIJE dst,src,RA

Operation: If $dst - src = "0"$, $PC \leftarrow PC + RA$
 $lr \leftarrow lr + 1$

The source operand is compared to (subtracted from) the destination operand. If the result is "0", the relative address is added to the program counter and control passes to the statement whose address is now in the program counter. Otherwise, the instruction immediately following the CPIJE instruction is executed. In either case, the source pointer is incremented by one before the next instruction is executed.

Flags: No flags are affected.

Format:

				Bytes	Cycles	Opcode (Hex)	Addr Mode <u>dst</u> <u>src</u>
opc	src	dst	RA	3	16/18	C2	r lr

NOTE: Execution time is 18 cycles if the jump is taken or 16 cycles if it is not taken.

Example: Given: R1 = 02H, R2 = 03H, and register 03H = 02H:

CPIJE R1,@R2,SKIP → R2 = 04H, PC jumps to SKIP location

In this example, the working register R1 contains the value 02H, the working register R2 the value 03H, and the register 03H contains 02H. The statement "CPIJE R1,@R2,SKIP" compares the @R2 value 02H (00000010B) to 02H (00000010B). Because the result of the comparison is *equal*, the relative address is added to the PC and the PC then jumps to the memory location pointed to by SKIP. The source register (R2) is incremented by one, leaving a value of 04H. (Remember that the memory location must be within the allowed range of + 127 to - 128.)

CPIJNE – Compare, Increment, and Jump on Non-Equal

CPIJNE dst,src,RA

Operation: If $dst - src \neq 0$, $PC \leftarrow PC + RA$
 $lr \leftarrow lr + 1$

The source operand is compared to (subtracted from) the destination operand. If the result is not "0", the relative address is added to the program counter and control passes to the statement whose address is now in the program counter; otherwise the instruction following the CPIJNE instruction is executed. In either case the source pointer is incremented by one before the next instruction.

Flags: No flags are affected.

Format:

				Bytes	Cycles	Opcode (Hex)	Addr Mode <u>dst</u> <u>src</u>
opc	src	dst	RA	3	16/18	D2	r lr

NOTE: Execution time is 18 cycles if the jump is taken or 16 cycles if it is not taken.

Example: Given: R1 = 02H, R2 = 03H, and register 03H = 04H:

CPIJNE R1,@R2,SKIP → R2 = 04H, PC jumps to SKIP location

The working register R1 contains the value 02H, the working register R2 (the source pointer) the value 03H, and the general register 03H contains the value 04H. The statement "CPIJNE R1,@R2,SKIP" subtracts 04H (00000100B) from 02H (00000010B). Because the result of the comparison is *non-equal*, the relative address is added to the PC and the PC then jumps to the memory location pointed to by SKIP. The source pointer register (R2) is also incremented by one, leaving a value of 04H. (Remember that the memory location must be within the allowed range of +127 to -128.)

DA – Decimal Adjust

DA dst

Operation: dst ← DA dst

The destination operand is adjusted to form two 4-bit BCD digits after an addition or subtraction operation. For addition (ADD, ADC) or subtraction (SUB, SBC), the following table indicates the operation performed. (The operation is undefined if the destination operand was not the result of a valid addition or subtraction of BCD digits):

Instruction	Carry Before DA	Bits 4–7 Value (Hex)	H Flag Before DA	Bits 0–3 Value (Hex)	Number Added to Byte	Carry After DA
	0	0–9	0	0–9	00	0
	0	0–8	0	A–F	06	0
	0	0–9	1	0–3	06	0
ADD	0	A–F	0	0–9	60	1
ADC	0	9–F	0	A–F	66	1
	0	A–F	1	0–3	66	1
	1	0–2	0	0–9	60	1
	1	0–2	0	A–F	66	1
	1	0–3	1	0–3	66	1
	0	0–9	0	0–9	00 = – 00	0
SUB	0	0–8	1	6–F	FA = – 06	0
SBC	1	7–F	0	0–9	A0 = – 60	1
	1	6–F	1	6–F	9A = – 66	1

Flags:

- C:** Set if there was a carry from the most significant bit; cleared otherwise (see table).
- Z:** Set if the result is "0"; cleared otherwise.
- S:** Set if the result bit 7 is set; cleared otherwise.
- V:** Undefined.
- D:** Unaffected.
- H:** Unaffected.

Format:

		Bytes	Cycles	Opcode (Hex)	Addr Mode <u>dst</u>
opc	dst	2	6	40	R
				41	IR

DA – Decimal Adjust

DA (Continued)

Example: Given: The working register R0 contains the value 15 (BCD), working register R1 contains 27 (BCD), and address 27H contains 46 (BCD):

```
ADD R1,R0 ; C ← "0", H ← "0", Bits 4–7 = 3, bits 0–3 = C, R1 ← 3CH
```

```
DA R1 ; R1 ← 3CH + 06
```

If an addition is performed using the BCD values 15 and 27, the result should be 42. The sum is incorrect, however, when the binary representations are added in the destination location using standard binary arithmetic:

```

  0 0 0 1  0 1 0 1      15
+ 0 0 1 0  0 1 1 1      27
-----
  0 0 1 1  1 1 0 0 =   3CH

```

The DA instruction adjusts this result so that the correct BCD representation is obtained:

```

  0 0 1 1  1 1 0 0
+ 0 0 0 0  0 1 1 0
-----
  0 1 0 0  0 0 1 0 =   42

```

Assuming the same values given above, the statements

```
SUB 27H,R0 ; C ← "0", H ← "0", Bits 4–7 = 3, bits 0–3 = 1
```

```
DA @R1 ; @R1 ← 31–0
```

leave the value 31 (BCD) in the address 27H (@R1).

DEC – Decrement

DEC dst

Operation: dst ← dst – 1

The contents of the destination operand are decremented by one.

Flags: **C:** Unaffected.
Z: Set if the result is "0"; cleared otherwise.
S: Set if the result is negative; cleared otherwise.
V: Set if arithmetic overflow occurred; cleared otherwise.
D: Unaffected.
H: Unaffected.

Format:

		Bytes	Cycles	Opcode (Hex)	Addr Mode <u>dst</u>
opc	dst	2	6	00	R
				01	IR

Examples: Given: R1 = 03H and register 03H = 10H:

DEC R1 → R1 = 02H

DEC @R1 → Register 03H = 0FH

In the first example, if the working register R1 contains the value 03H, the statement "DEC R1" decrements the hexadecimal value by one, leaving the value 02H. In the second example, the statement "DEC @R1" decrements the value 10H contained in the destination register 03H by one, leaving the value 0FH.

DECW – Decrement Word

DECW dst

Operation: dst ← dst – 1

The contents of the destination location (which must be an even address) and the operand following that location are treated as a single 16-bit value that is decremented by one.

- Flags:**
- C:** Unaffected.
 - Z:** Set if the result is "0"; cleared otherwise.
 - S:** Set if the result is negative; cleared otherwise.
 - V:** Set if arithmetic overflow occurred; cleared otherwise.
 - D:** Unaffected.
 - H:** Unaffected.

Format:

		Bytes	Cycles	Opcode (Hex)	Addr Mode <u>dst</u>
opc	dst	2	10	80	RR
				81	IR

Examples: Given: R0 = 12H, R1 = 34H, R2 = 30H, register 30H = 0FH, and register 31H = 21H:

DECW RR0 → R0 = 12H, R1 = 33H

DECW @R2 → Register 30H = 0FH, register 31H = 20H

In the first example, the destination register R0 contains the value 12H and the register R1 the value 34H. The statement "DECW RR0" addresses R0 and the following operand R1 as a 16-bit word and decrements the value of R1 by one, leaving the value 33H.

NOTE: A system malfunction may occur if you use a Zero flag (FLAGS.6) result together with a DECW instruction. To avoid this problem, we recommend that you use DECW as shown in the following example:

```

LOOP:  DECW  R0
        LD   R2,R1
        OR   R2,R0
        JR   NZ,LOOP
    
```

DI – Disable Interrupts

DI

Operation: SYM (0) ← 0

Bit zero of the system mode control register, SYM.0, is cleared to "0", globally disabling all interrupt processing. Interrupt requests will continue to set their respective interrupt pending bits, but the CPU will not service them while interrupt processing is disabled.

Flags: No flags are affected.

Format:

	Bytes	Cycles	Opcode (Hex)
opc	1	6	8F

Example: Given: SYM = 01H:

DI

If the value of the SYM register is 01H, the statement "DI" leaves the new value 00H in the register and clears SYM.0 to "0", disabling interrupt processing.

DIV – Divide (Unsigned)

DIV dst,src

Operation: dst \div src
 dst (UPPER) \leftarrow REMAINDER
 dst (LOWER) \leftarrow QUOTIENT

The destination operand (16 bits) is divided by the source operand (8 bits). The quotient (8 bits) is stored in the lower half of the destination. The remainder (8 bits) is stored in the upper half of the destination. When the quotient is $\geq 2^8$, the numbers stored in the upper and lower halves of the destination for quotient and remainder are incorrect. Both operands are treated as unsigned integers.

Flags:

- C:** Set if the V flag is set and the quotient is between 2^8 and $2^9 - 1$; cleared otherwise.
- Z:** Set if the divisor or quotient = "0"; cleared otherwise.
- S:** Set if the MSB of quotient = "1"; cleared otherwise.
- V:** Set if the quotient is $\geq 2^8$ or if the divisor = "0"; cleared otherwise.
- D:** Unaffected.
- H:** Unaffected.

Format:

			Bytes	Cycles	Opcode (Hex)	Addr Mode <u>dst</u> <u>src</u>
opc	src	dst	3	28/12 *	94	RR R
				28/12 *	95	RR IR
				28/12 *	96	RR IM

* Execution takes 12 cycles if divide-by-zero is attempted; otherwise it takes 28 cycles.

Examples: Given: R0 = 10H, R1 = 03H, R2 = 40H, register 40H = 80H:

DIV RR0,R2 \rightarrow R0 = 03H, R1 = 40H

DIV RR0,@R2 \rightarrow R0 = 03H, R1 = 20H

DIV RR0,#20H \rightarrow R0 = 03H, R1 = 80H

In the first example, the destination working register pair RR0 contains the values 10H (R0) and 03H (R1), and the register R2 contains the value 40H. The statement "DIV RR0,R2" divides the 16-bit RR0 value by the 8-bit value of the R2 (source) register. After the DIV instruction, R0 contains the value 03H and R1 contains 40H. The 8-bit remainder is stored in the upper half of the destination register RR0 (R0) and the quotient in the lower half (R1).

DJNZ – Decrement and Jump if Non-Zero

DJNZ r,dst

Operation: $r \leftarrow r - 1$
 If $r \neq 0, PC \leftarrow PC + dst$

The working register being used as a counter is decremented. If the contents of the register are not logic zero after decrementing, the relative address is added to the program counter and control passes to the statement whose address is now in the PC. The range of the relative address is +127 to -128, and the original value of the PC is taken to be the address of the instruction byte following the DJNZ statement.

Flags: No flags are affected.

Format:

	Bytes	Cycles	Opcode (Hex)	Addr Mode <u>dst</u>					
<table border="1" style="display: inline-table;"> <tr> <td style="padding: 2px 5px;">r</td> <td style="padding: 2px 5px;"> </td> <td style="padding: 2px 5px;">opc</td> <td style="padding: 2px 5px;"> </td> <td style="padding: 2px 5px;">dst</td> </tr> </table>	r		opc		dst	2	12 (jump taken) 10 (no jump)	rA r = 0 to F	RA
r		opc		dst					

Example: Given: R1 = 02H and LOOP is the label of a relative address:

DJNZ R1,LOOP

DJNZ is typically used to control a "loop" of instructions. In many cases, a label is used as the destination operand instead of a numeric relative address value. In the example, the working register R1 contains the value 02H, and LOOP is the label for a relative address.

The statement "DJNZ R1, LOOP" decrements the register R1 by one, leaving the value 01H. Because the contents of R1 after the decrement are non-zero, the jump is taken to the relative address specified by the LOOP label.

NOTE: When PP = 11H or 10H and working register area is NOT in C0H–CFH, DJNZ instruction can not be used.

EI – Enable Interrupts

EI

Operation: SYM (0) \leftarrow 1

An EI instruction sets bit zero of the system mode register, SYM.0 to "1". This allows interrupts to be serviced as they occur (assuming they have highest priority). If an interrupt's pending bit was set while interrupt processing was disabled (by executing a DI instruction), it will be serviced when you execute the EI instruction.

Flags: No flags are affected.

Format:

	Bytes	Cycles	Opcode (Hex)
opc	1	6	9F

Example: Given: SYM = 00H:

EI

If the SYM register contains the value 00H, that is, if interrupts are currently disabled, the statement "EI" sets the SYM register to 01H, enabling all interrupts. (SYM.0 is the enable bit for global interrupt processing.)

ENTER – Enter

ENTER

Operation:

```

SP ← SP - 2
@SP ← IP
IP ← PC
PC ← @IP
IP ← IP + 2
    
```

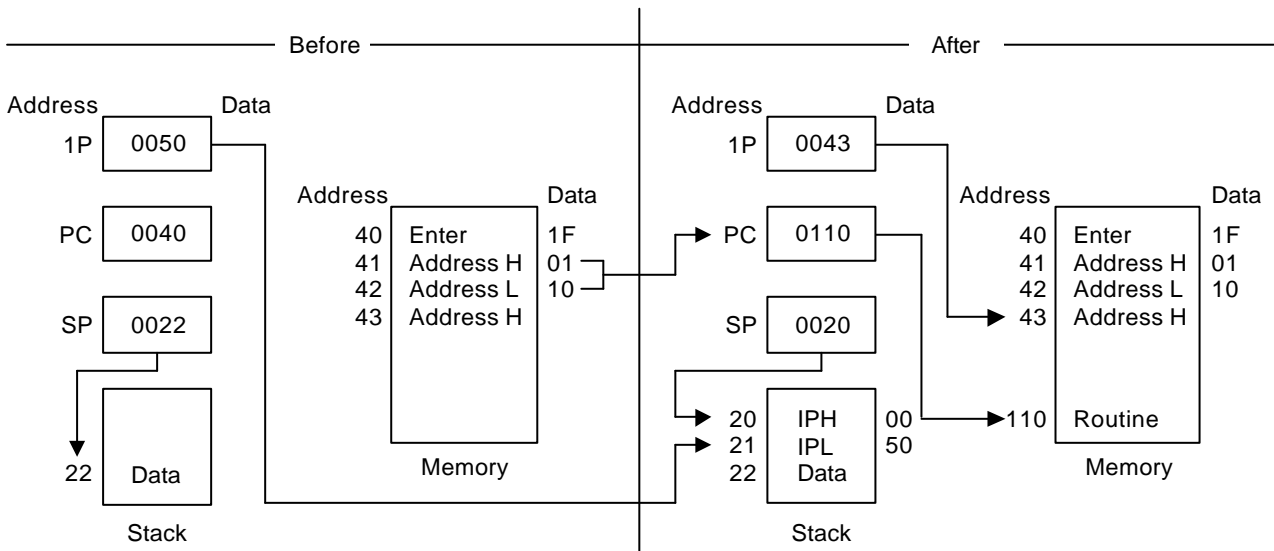
This instruction is useful when implementing threaded-code languages. The contents of the instruction pointer are pushed to the stack. The program counter (PC) value is then written to the instruction pointer. The program memory word that is pointed to by the instruction pointer is loaded into the PC, and the instruction pointer is incremented by two.

Flags: No flags are affected.

Format:

	Bytes	Cycles	Opcode (Hex)
opc	1	20	1F

Example: The diagram below shows one example of how to use an ENTER statement.



EXIT – Exit

EXIT

Operation:

```

IP ← @SP
SP ← SP + 2
PC ← @IP
IP ← IP + 2
    
```

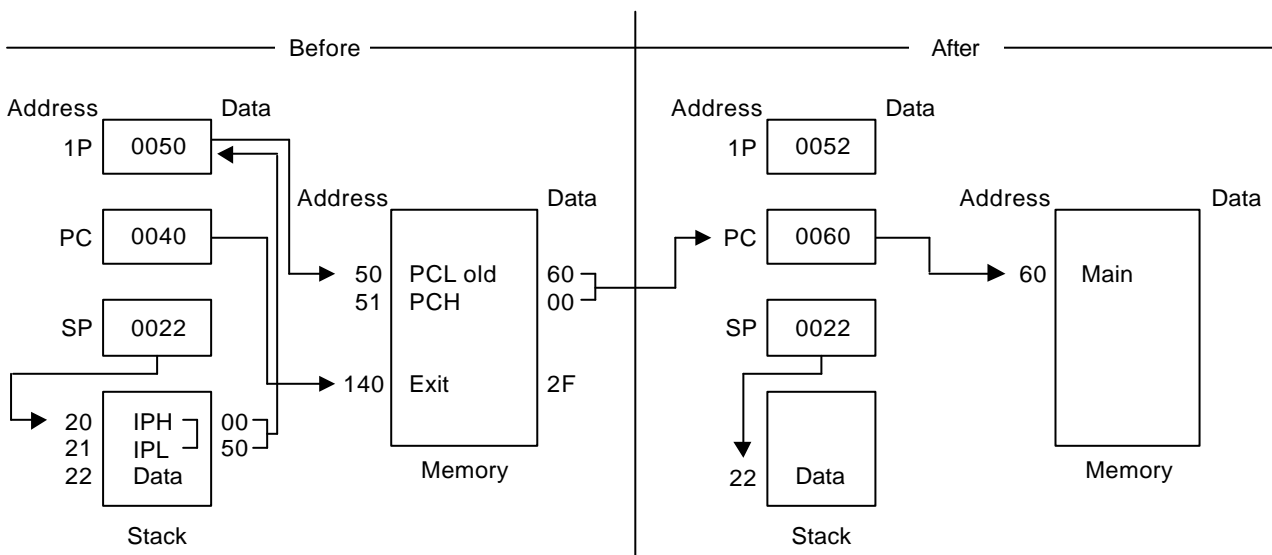
This instruction is useful when implementing threaded-code languages. The stack value is popped and loaded into the instruction pointer. The program memory word that is pointed to by the instruction pointer is then loaded into the program counter, and the instruction pointer is incremented by two.

Flags: No flags are affected.

Format:

	Bytes	Cycles	Opcode (Hex)
opc	1	22	2F

Example: The diagram below shows one example of how to use an EXIT statement.



IDLE – Idle Operation

IDLE

Operation:

The IDLE instruction stops the CPU clock while allowing system clock oscillation to continue. Idle mode can be released by an interrupt request (IRQ) or an external reset operation.

Flags: No flags are affected.

Format:

	Bytes	Cycles	Opcode (Hex)	Addr Mode <u>dst</u>	<u>src</u>
<div style="border: 1px solid black; display: inline-block; padding: 2px 10px;">opc</div>	1	3	6F	–	–

Example: The instruction

IDLE

stops the CPU clock but not the system clock.

INC – Increment

INC dst

Operation: dst ← dst + 1

The contents of the destination operand are incremented by one.

- Flags:**
- C:** Unaffected.
 - Z:** Set if the result is "0"; cleared otherwise.
 - S:** Set if the result is negative; cleared otherwise.
 - V:** Set if arithmetic overflow occurred; cleared otherwise.
 - D:** Unaffected.
 - H:** Unaffected.

Format:

	Bytes	Cycles	Opcode (Hex)	Addr Mode <u>dst</u>
<div style="border: 1px solid black; padding: 2px; display: inline-block;">dst opc</div>	1	6	rE r = 0 to F	r
<div style="display: inline-block; border: 1px solid black; padding: 2px;">opc</div> <div style="display: inline-block; border: 1px solid black; padding: 2px; margin-left: 10px;">dst</div>	2	6	20 21	R IR

Examples: Given: R0 = 1BH, register 00H = 0CH, and register 1BH = 0FH:

- INC R0 → R0 = 1CH
- INC 00H → Register 00H = 0DH
- INC @R0 → R0 = 1BH, register 01H = 10H

In the first example, if the destination working register R0 contains the value 1BH, the statement "INC R0" leaves the value 1CH in that same register.

The next example shows the effect an INC instruction has on the register 00H, assuming that it contains the value 0CH.

In the third example, INC is used in Indirect Register (IR) addressing mode to increment the value of the register 1BH from 0FH to 10H.

INCW – Increment Word

INCW dst

Operation: dst ← dst + 1

The contents of the destination (which must be an even address) and the byte following that location are treated as a single 16-bit value that is incremented by one.

Flags: **C:** Unaffected.
Z: Set if the result is "0"; cleared otherwise.
S: Set if the result is negative; cleared otherwise.
V: Set if arithmetic overflow occurred; cleared otherwise.
D: Unaffected.
H: Unaffected.

Format:

		Bytes	Cycles	Opcode (Hex)	Addr Mode <u>dst</u>
opc	dst	2	10	A0	RR
				A1	IR

Examples: Given: R0 = 1AH, R1 = 02H, register 02H = 0FH, and register 03H = 0FFH:

INCW RR0 → R0 = 1AH, R1 = 03H

INCW @R1 → Register 02H = 10H, register 03H = 00H

In the first example, the working register pair RR0 contains the value 1AH in the register R0 and 02H in the register R1. The statement "INCW RR0" increments the 16-bit destination by one, leaving the value 03H in the register R1. In the second example, the statement "INCW @R1" uses Indirect Register (IR) addressing mode to increment the contents of the general register 03H from 0FFH to 00H and the register 02H from 0FH to 10H.

NOTE: A system malfunction may occur if you use a Zero (Z) flag (FLAGS.6) result together with an INCW instruction. To avoid this problem, we recommend that you use INCW as shown in the following example:

```

LOOP:  INCW   RR0
        LD    R2,R1
        OR   R2,R0
        JR   NZ,LOOP
    
```

IRET – Interrupt Return

IRET	<u>IRET (Normal)</u>	<u>IRET (Fast)</u>
Operation:	$FLAGS \leftarrow @SP$ $SP \leftarrow SP + 1$ $PC \leftarrow @SP$ $SP \leftarrow SP + 2$ $SYM(0) \leftarrow 1$	$PC \leftrightarrow IP$ $FLAGS \leftarrow FLAGS'$ $FIS \leftarrow 0$

This instruction is used at the end of an interrupt service routine. It restores the flag register and the program counter. It also re-enables global interrupts. A "normal IRET" is executed only if the fast interrupt status bit (FIS, bit one of the FLAGS register, 0D5H) is cleared (= "0"). If a fast interrupt occurred, IRET clears the FIS bit that was set at the beginning of the service routine.

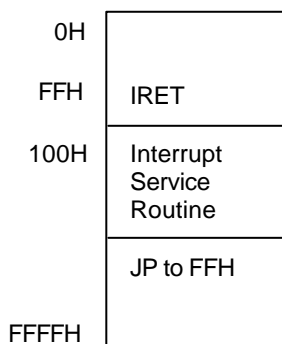
Flags: All flags are restored to their original settings (that is, the settings before the interrupt occurred).

Format:

IRET (Normal)	Bytes	Cycles	Opcode (Hex)
opc	1	16	BF

IRET (Fast)	Bytes	Cycles	Opcode (Hex)
opc	1	6	BF

Example: In the figure below, the instruction pointer is initially loaded with 100H in the main program before interrupts are enabled. When an interrupt occurs, the program counter and the instruction pointer are swapped. This causes the PC to jump to the address 100H and the IP to keep the return address. The last instruction in the service routine normally is a jump to IRET at the address FFH. This causes the instruction pointer to be loaded with 100H "again" and the program counter to jump back to the main program. Now, the next interrupt can occur and the IP is still correct at 100H.



Note that in the fast interrupt example above, if the last instruction is not a jump to IRET, you must pay attention to the order of the last two instructions. The IRET cannot be immediately preceded by clearing the interrupt status (as with a reset of the IPR register).

JP – Jump

JP cc,dst (Conditional)

JP dst (Unconditional)

Operation: If cc is true, PC ← dst

The conditional JUMP instruction transfers program control to the destination address if the condition specified by the condition code (cc) is true; otherwise, the instruction following the JP instruction is executed. The unconditional JP simply replaces the contents of the PC with the contents of the specified register pair. Control then passes to the statement addressed by the PC.

Flags: No flags are affected.

Format: (1)

(2)		Bytes	Cycles	Opcode (Hex)	Addr Mode
cc opc	dst	3	10/12 (3)	ccD	DA
cc = 0 to F					
opc	dst	2	10	30	IRR

NOTES:

1. The 3-byte format is used for a conditional jump and the 2-byte format for an unconditional jump.
2. In the first byte of the 3-byte instruction format (conditional jump), the condition code and the opcode are both four bits.
3. For a conditional jump, execution time is 12 cycles if the jump is taken or 10 cycles if it is not taken.

Examples: Given: The carry flag (C) = "1", register 00 = 01H, and register 01 = 20H:

JP C,LABEL_W → LABEL_W = 1000H, PC = 1000H

JP @00H → PC = 0120H

The first example shows a conditional JP. Assuming that the carry flag is set to "1", the statement "JP C,LABEL_W" replaces the contents of the PC with the value 1000H and transfers control to that location. Had the carry flag not been set, control would then have passed to the statement immediately following the JP instruction.

The second example shows an unconditional JP. The statement "JP @00" replaces the contents of the PC with the contents of the register pair 00H and 01H, leaving the value 0120H.

JR – Jump Relative

JR cc,dst

Operation: If cc is true, $PC \leftarrow PC + dst$

If the condition specified by the condition code (cc) is true, the relative address is added to the program counter and control passes to the statement whose address is now in the program counter; otherwise, the instruction following the JR instruction is executed. (See the list of condition codes).

The range of the relative address is +127 to -128, and the original value of the program counter is taken to be the address of the first instruction byte following the JR statement.

Flags: No flags are affected.

Format:

(1)	Bytes	Cycles	Opcode (Hex)	Addr Mode <u>dst</u>					
<table border="1" style="margin: auto;"> <tr> <td style="padding: 2px 5px;">cc</td> <td style="padding: 2px 5px;"> </td> <td style="padding: 2px 5px;">opc</td> <td style="padding: 2px 5px;"> </td> <td style="padding: 2px 5px;">dst</td> </tr> </table>	cc		opc		dst	2	10/12 (2)	ccB	RA
cc		opc		dst					
			cc = 0 to F						

NOTES:

1. In the first byte of the two-byte instruction format, the condition code and the opcode are four bits each.
2. Instruction execution time is 12 cycles if the jump is taken or 10 cycles if it is not taken.

Example: Given: The carry flag = "1" and LABEL_X = 1FF7H:

JR C,LABEL_X → PC = 1FF7H

If the carry flag is set (that is, if the condition code is true), the statement "JR C,LABEL_X" will pass control to the statement whose address is now in the PC. Otherwise, the program instruction following the JR would be executed.

LD – Load

LD dst,src

Operation: dst ← src

The contents of the source are loaded into the destination. The source's contents are unaffected.

Flags: No flags are affected.

Format:

			Bytes	Cycles	Opcode (Hex)	Addr <u>dst</u>	Mode <u>src</u>
dst opc	src		2	6	rC	r	IM
				6	r8	r	R
src opc	dst		2	6	r9	R	r
opc	dst src		2	6	C7	r	lr
				6	D7	lr	r
opc	src	dst	3	10	E4	R	R
				10	E5	R	IR
opc	dst	src	3	10	E6	R	IM
				10	D6	IR	IM
opc	src	dst	3	10	F5	IR	R
opc	dst src	x	3	10	87	r	x [r]
opc	src dst	x	3	10	97	x [r]	r

LD – Load

LD (Continued)

Examples: Given: R0 = 01H, R1 = 0AH, register 00H = 01H, register 01H = 20H, register 02H = 02H, LOOP = 30H, and register 3AH = 0FFH:

LD	R0,#10H	→	R0 = 10H
LD	R0,01H	→	R0 = 20H, register 01H = 20H
LD	01H,R0	→	Register 01H = 01H, R0 = 01H
LD	R1,@R0	→	R1 = 20H, R0 = 01H
LD	@R0,R1	→	R0 = 01H, R1 = 0AH, register 01H = 0AH
LD	00H,01H	→	Register 00H = 20H, register 01H = 20H
LD	02H,@00H	→	Register 02H = 20H, register 00H = 01H
LD	00H,#0AH	→	Register 00H = 0AH
LD	@00H,#10H	→	Register 00H = 01H, register 01H = 10H
LD	@00H,02H	→	Register 00H = 01H, register 01H = 02H, register 02H = 02H
LD	R0,#LOOP[R1]	→	R0 = 0FFH, R1 = 0AH
LD	#LOOP[R0],R1	→	Register 31H = 0AH, R0 = 01H, R1 = 0AH

LDB – Load Bit

LDB dst,src.b

LDB dst.b,src

Operation: dst(0) ← src(b)
 or
 dst(b) ← src(0)

The specified bit of the source is loaded into bit zero (LSB) of the destination, or bit zero of the source is loaded into the specified bit of the destination. No other bits of the destination are affected. The source is unaffected.

Flags: No flags are affected.

Format:

			Bytes	Cycles	Opcode (Hex)	Addr Mode <u>dst</u> <u>src</u>
opc	dst b 0	src	3	10	47	r0 Rb
opc	src b 1	dst	3	10	47	Rb r0

NOTE: In the second byte of the instruction format, the destination (or source) address is four bits, the bit address 'b' is three bits, and the LSB address value is one bit in length.

Examples: Given: R0 = 06H and general register 00H = 05H:

LDB R0,00H.2 → R0 = 07H, register 00H = 05H

LDB 00H.0,R0 → R0 = 06H, register 00H = 04H

In the first example, the destination working register R0 contains the value 06H and the source general register 00H the value 05H. The statement "LD R0,00H.2" loads the bit two value of the 00H register into bit zero of the R0 register, leaving the value 07H in the register R0.

In the second example, 00H is the destination register. The statement "LD 00H.0,R0" loads bit zero of the register R0 to the specified bit (bit zero) of the destination register, leaving 04H in the general register 00H.

LDC/LDE – Load Memory

LDC/LDE dst,src

Operation: dst ← src

This instruction loads a byte from program or data memory into a working register or vice-versa. The source values are unaffected. LDC refers to program memory and LDE to data memory. The assembler makes 'lrr' or 'rr' values an even number for program memory and an odd number for data memory.

Flags: No flags are affected.

Format:

		Bytes	Cycles	Opcode (Hex)	Addr <u>dst</u>	Mode <u>src</u>				
1.	<table border="1"><tr><td>opc</td><td>dst src</td></tr></table>	opc	dst src	2	12	C3	r	lrr		
opc	dst src									
2.	<table border="1"><tr><td>opc</td><td>src dst</td></tr></table>	opc	src dst	2	12	D3	lrr	r		
opc	src dst									
3.	<table border="1"><tr><td>opc</td><td>dst src</td><td>XS</td></tr></table>	opc	dst src	XS	3	18	E7	r	XS [rr]	
opc	dst src	XS								
4.	<table border="1"><tr><td>opc</td><td>src dst</td><td>XS</td></tr></table>	opc	src dst	XS	3	18	F7	XS [rr]	r	
opc	src dst	XS								
5.	<table border="1"><tr><td>opc</td><td>dst src</td><td>XL_L</td><td>XL_H</td></tr></table>	opc	dst src	XL _L	XL _H	4	20	A7	r	XL [rr]
opc	dst src	XL _L	XL _H							
6.	<table border="1"><tr><td>opc</td><td>src dst</td><td>XL_L</td><td>XL_H</td></tr></table>	opc	src dst	XL _L	XL _H	4	20	B7	XL [rr]	r
opc	src dst	XL _L	XL _H							
7.	<table border="1"><tr><td>opc</td><td>dst 0000</td><td>DA_L</td><td>DA_H</td></tr></table>	opc	dst 0000	DA _L	DA _H	4	20	A7	r	DA
opc	dst 0000	DA _L	DA _H							
8.	<table border="1"><tr><td>opc</td><td>src 0000</td><td>DA_L</td><td>DA_H</td></tr></table>	opc	src 0000	DA _L	DA _H	4	20	B7	DA	r
opc	src 0000	DA _L	DA _H							
9.	<table border="1"><tr><td>opc</td><td>dst 0001</td><td>DA_L</td><td>DA_H</td></tr></table>	opc	dst 0001	DA _L	DA _H	4	20	A7	r	DA
opc	dst 0001	DA _L	DA _H							
10.	<table border="1"><tr><td>opc</td><td>src 0001</td><td>DA_L</td><td>DA_H</td></tr></table>	opc	src 0001	DA _L	DA _H	4	20	B7	DA	r
opc	src 0001	DA _L	DA _H							

NOTES:

1. The source (src) or the working register pair [rr] for formats 5 and 6 cannot use the register pair 0–1.
2. For formats 3 and 4, the destination address 'XS [rr]' and the source address 'XS [rr]' are one byte each.
3. For formats 5 and 6, the destination address 'XL [rr]' and the source address 'XL [rr]' are two bytes each.
4. The DA and r source values for formats 7 and 8 are used to address program memory; the second set of values, used in formats 9 and 10, are used to address data memory.

LDC/LDE – Load Memory

LDC/LDE (Continued)

Examples: Given: R0 = 11H, R1 = 34H, R2 = 01H, R3 = 04H; Program memory locations 0103H = 4FH, 0104H = 1A, 0105H = 6DH, and 1104H = 88H. External data memory locations 0103H = 5FH, 0104H = 2AH, 0105H = 7DH, and 1104H = 98H:

LDC	R0,@RR2	; R0 ← contents of program memory location 0104H ; R0 = 1AH, R2 = 01H, R3 = 04H
LDE	R0,@RR2	; R0 ← contents of external data memory location 0104H ; R0 = 2AH, R2 = 01H, R3 = 04H
LDC (note)	@RR2,R0	; 11H (contents of R0) is loaded into program memory ; location 0104H (RR2), ; working registers R0, R2, R3 → no change
LDE	@RR2,R0	; 11H (contents of R0) is loaded into external data memory ; location 0104H (RR2), ; working registers R0, R2, R3 → no change
LDC	R0,#01H[RR2]	; R0 ← contents of program memory location 0105H ; (01H + RR2), ; R0 = 6DH, R2 = 01H, R3 = 04H
LDE	R0,#01H[RR2]	; R0 ← contents of external data memory location 0105H ; (01H + RR2), R0 = 7DH, R2 = 01H, R3 = 04H
LDC (note)	#01H[RR2],R0	; 11H (contents of R0) is loaded into program memory location ; 0105H (01H + 0104H)
LDE	#01H[RR2],R0	; 11H (contents of R0) is loaded into external data memory ; location 0105H (01H + 0104H)
LDC	R0,#1000H[RR2]	; R0 ← contents of program memory location 1104H ; (1000H + 0104H), R0 = 88H, R2 = 01H, R3 = 04H
LDE	R0,#1000H[RR2]	; R0 ← contents of external data memory location 1104H ; (1000H + 0104H), R0 = 98H, R2 = 01H, R3 = 04H
LDC	R0,1104H	; R0 ← contents of program memory location 1104H, R0 = 88H
LDE	R0,1104H	; R0 ← contents of external data memory location 1104H, ; R0 = 98H
LDC (note)	1105H,R0	; 11H (contents of R0) is loaded into program memory location ; 1105H, (1105H) ← 11H
LDE	1105H,R0	; 11H (contents of R0) is loaded into external data memory ; location 1105H, (1105H) ← 11H

NOTE: These instructions are not supported by masked ROM type devices.

LDCD/LDED – Load Memory and Decrement

LDCD/LDED dst,src

Operation: dst ← src
rr ← rr – 1

These instructions are used for user stacks or block transfers of data from program or data memory to the register file. The address of the memory location is specified by a working register pair. The contents of the source location are loaded into the destination location. The memory address is then decremented. The contents of the source are unaffected.

LDCD refers to program memory and LDED refers to external data memory. The assembler makes 'lrr' an even number for program memory and an odd number for data memory.

Flags: No flags are affected.

Format:

		Bytes	Cycles	Opcode (Hex)	Addr Mode <u>dst</u> <u>src</u>
opc	dst src	2	16	E2	r lrr

Examples: Given: R6 = 10H, R7 = 33H, R8 = 12H, program memory location 1033H = 0CDH, and external data memory location 1033H = 0DDH:

```
LDCD    R8,@RR6    ; 0CDH (contents of program memory location 1033H) is loaded
           ; into R8 and RR6 is decremented by one
           ; R8 = 0CDH, R6 = 10H, R7 = 32H (RR6 ← RR6 – 1)

LDED    R8,@RR6    ; 0DDH (contents of data memory location 1033H) is loaded
           ; into R8 and RR6 is decremented by one (RR6 ← RR6 – 1)
           ; R8 = 0DDH, R6 = 10H, R7 = 32H
```

LDCI/LDEI – Load Memory and Increment

LDCI/LDEI dst,src

Operation: dst ← src
 rr ← rr + 1

These instructions are used for user stacks or block transfers of data from program or data memory to the register file. The address of the memory location is specified by a working register pair. The contents of the source location are loaded into the destination location. The memory address is then incremented automatically. The contents of the source are unaffected.

LDCI refers to program memory and LDEI refers to external data memory. The assembler makes 'lrr' even number for program memory and odd number for data memory.

Flags: No flags are affected.

Format:

		Bytes	Cycles	Opcode (Hex)	Addr Mode <u>dst</u> <u>src</u>
opc	dst src	2	16	E3	r lrr

Examples: Given: R6 = 10H, R7 = 33H, R8 = 12H, program memory locations 1033H = 0CDH and 1034H = 0C5H; external data memory locations 1033H = 0DDH and 1034H = 0D5H:

LDCI R8,@RR6 ; 0CDH (contents of program memory location 1033H) is loaded
 ; into R8 and RR6 is incremented by one (RR6 ← RR6 + 1)
 ; R8 = 0CDH, R6 = 10H, R7 = 34H

LDEI R8,@RR6 ; 0DDH (contents of data memory location 1033H) is loaded
 ; into R8 and RR6 is incremented by one (RR6 ← RR6 + 1)
 ; R8 = 0DDH, R6 = 10H, R7 = 34H

LDCPD/LDEPD – Load Memory with Pre-Decrement

LDCPD/

LDEPD dst,src

Operation: $rr \leftarrow rr - 1$
 $dst \leftarrow src$

These instructions are used for block transfers of data from program or data memory from the register file. The address of the memory location is specified by a working register pair and is first decremented. The contents of the source location are then loaded into the destination location. The contents of the source are unaffected.

LDCPD refers to program memory and LDEPD refers to external data memory. The assembler makes 'lrr' an even number for program memory and an odd number for external data memory.

Flags: No flags are affected.

Format:

		Bytes	Cycles	Opcode (Hex)	Addr Mode <u>dst</u>	<u>src</u>
opc	src dst	2	16	F2	lrr	r

Examples: Given: R0 = 77H, R6 = 30H, and R7 = 00H:

```
LDCPD  @RR6,R0      ; (RR6 ← RR6 – 1)
                          ; 77H (contents of R0) is loaded into program memory location
                          ; 2FFFH (3000H – 1H)
                          ; R0 = 77H, R6 = 2FH, R7 = 0FFH

LDEPD  @RR6,R0      ; (RR6 ← RR6 – 1)
                          ; 77H (contents of R0) is loaded into external data memory
                          ; location 2FFFH (3000H – 1H)
                          ; R0 = 77H, R6 = 2FH, R7 = 0FFH
```

LDCPI/LDEPI – Load Memory with Pre-Increment

LDCPI/

LDEPI dst,src

Operation: $rr \leftarrow rr + 1$
 $dst \leftarrow src$

These instructions are used for block transfers of data from program or data memory from the register file. The address of the memory location is specified by a working register pair and is first incremented. The contents of the source location are loaded into the destination location. The contents of the source are unaffected.

LDCPI refers to program memory and LDEPI refers to external data memory. The assembler makes 'lrr' an even number for program memory and an odd number for data memory.

Flags: No flags are affected.

Format:

		Bytes	Cycles	Opcode (Hex)	Addr Mode <u>dst</u>	<u>src</u>
opc	src dst	2	16	F3	lrr	r

Examples: Given: R0 = 7FH, R6 = 21H, and R7 = 0FFH:

```
LDCPI    @RR6,R0            ; (RR6 ← RR6 + 1)
                              ; 7FH (contents of R0) is loaded into program memory
                              ; location 2200H (21FFH + 1H)
                              ; R0 = 7FH, R6 = 22H, R7 = 00H
```

```
LDEPI    @RR6,R0            ; (RR6 ← RR6 + 1)
                              ; 7FH (contents of R0) is loaded into external data memory
                              ; location 2200H (21FFH + 1H)
                              ; R0 = 7FH, R6 = 22H, R7 = 00H
```

LDW – Load Word

LDW dst,src

Operation: dst ← src

The contents of the source (a word) are loaded into the destination. The contents of the source are unaffected.

Flags: No flags are affected.

Format:

			Bytes	Cycles	Opcode (Hex)	Addr <u>dst</u>	Mode <u>src</u>
opc	src	dst	3	10	C4	RR	RR
				10	C5	RR	IR
opc	dst	src	4	12	C6	RR	IML

Examples: Given: R4 = 06H, R5 = 1CH, R6 = 05H, R7 = 02H, register 00H = 1AH, register 01H = 02H, register 02H = 03H, and register 03H = 0FH:

LDW RR6,RR4 → R6 = 06H, R7 = 1CH, R4 = 06H, R5 = 1CH

LDW 00H,02H → Register 00H = 03H, register 01H = 0FH, register 02H = 03H, register 03H = 0FH

LDW RR2,@R7 → R2 = 03H, R3 = 0FH,

LDW 04H,@01H → Register 04H = 03H, register 05H = 0FH

LDW RR6,#1234H → R6 = 12H, R7 = 34H

LDW 02H,#0FEDH → Register 02H = 0FH, register 03H = 0EDH

In the second example, please note that the statement "LDW 00H,02H" loads the contents of the source word 02H, 03H into the destination word 00H, 01H. This leaves the value 03H in the general register 00H and the value 0FH in the register 01H.

Other examples show how to use the LDW instruction with various addressing modes and formats.

MULT – Multiply (Unsigned)

MULT dst,src

Operation: dst ← dst × src

The 8-bit destination operand (the even register of the register pair) is multiplied by the source operand (8 bits) and the product (16 bits) is stored in the register pair specified by the destination address. Both operands are treated as unsigned integers.

Flags:
C: Set if the result is > 255; cleared otherwise.
Z: Set if the result is "0"; cleared otherwise.
S: Set if MSB of the result is a "1"; cleared otherwise.
V: Cleared.
D: Unaffected.
H: Unaffected.

Format:

			Bytes	Cycles	Opcode (Hex)	Addr Mode			
						<u>dst</u> <u>src</u>			
<table border="1" style="width: 100%; text-align: center;"> <tr> <td style="width: 33%;">opc</td> <td style="width: 33%;">src</td> <td style="width: 33%;">dst</td> </tr> </table>	opc	src	dst			3	24	84	RR R
	opc	src	dst						
					24	85	RR IR		
				24	86	RR IM			

Examples: Given: Register 00H = 20H, register 01H = 03H, register 02H = 09H, register 03H = 06H:

- MULT 00H, 02H → Register 00H = 01H, register 01H = 20H, register 02H = 09H
- MULT 00H, @01H → Register 00H = 00H, register 01H = 0C0H
- MULT 00H, #30H → Register 00H = 06H, register 01H = 00H

In the first example, the statement "MULT 00H,02H" multiplies the 8-bit destination operand (in the register 00H of the register pair 00H, 01H) by the source register 02H operand (09H). The 16-bit product, 0120H, is stored in the register pair 00H, 01H.

NEXT – Next

NEXT

Operation: PC ← @IP
 IP ← IP + 2

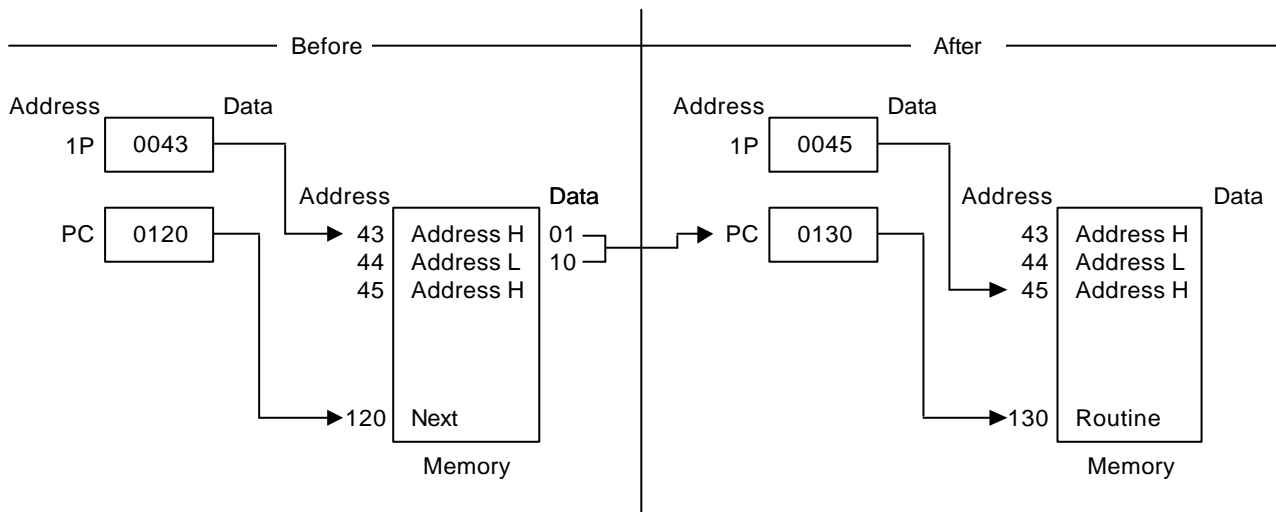
The NEXT instruction is useful when implementing threaded-code languages. The program memory word that is pointed to by the instruction pointer is loaded into the program counter. The instruction pointer is then incremented by two.

Flags: No flags are affected.

Format:

	Bytes	Cycles	Opcode (Hex)
opc	1	14	0F

Example: The following diagram shows one example of how to use the NEXT instruction.



NOP – No Operation

NOP

Operation: No action is performed when the CPU executes this instruction. Typically, one or more NOPs are executed in sequence in order to effect a timing delay of variable duration.

Flags: No flags are affected.

Format:

	Bytes	Cycles	Opcode (Hex)	
<table border="1"><tr><td>opc</td></tr></table>	opc	1	6	FF
opc				

Example: When the instruction

NOP

is encountered in a program, no operation occurs. Instead, there happens a delay in instruction execution.

OR – Logical OR

OR dst,src

Operation: dst ← dst OR src

The source operand is logically ORed with the destination operand and the result is stored in the destination. The contents of the source are unaffected. The OR operation results in a "1" being stored whenever either of the corresponding bits in the two operands is a "1"; otherwise a "0" is stored.

Flags:
C: Unaffected.
Z: Set if the result is "0"; cleared otherwise.
S: Set if the result bit 7 is set; cleared otherwise.
V: Always cleared to "0".
D: Unaffected.
H: Unaffected.

Format:

		Bytes	Cycles	Opcode (Hex)	Addr <u>dst</u>	Mode <u>src</u>			
<table border="1" style="display: inline-table; vertical-align: middle;"> <tr> <td style="padding: 2px 10px;">opc</td> <td style="padding: 2px 10px;">dst src</td> </tr> </table>	opc	dst src		2	6	42	r	r	
	opc	dst src							
			6	43	r	lr			
<table border="1" style="display: inline-table; vertical-align: middle;"> <tr> <td style="padding: 2px 10px;">opc</td> <td style="padding: 2px 10px;">src</td> <td style="padding: 2px 10px;">dst</td> </tr> </table>	opc	src	dst		3	10	44	R	R
	opc	src	dst						
			10	45	R	IR			
<table border="1" style="display: inline-table; vertical-align: middle;"> <tr> <td style="padding: 2px 10px;">opc</td> <td style="padding: 2px 10px;">dst</td> <td style="padding: 2px 10px;">src</td> </tr> </table>	opc	dst	src		3	10	46	R	IM
opc	dst	src							

Examples: Given: R0 = 15H, R1 = 2AH, R2 = 01H, register 00H = 08H, register 01H = 37H, and register 08H = 8AH:

OR R0,R1 → R0 = 3FH, R1 = 2AH
 OR R0,@R2 → R0 = 37H, R2 = 01H, register 01H = 37H
 OR 00H,01H → Register 00H = 3FH, register 01H = 37H
 OR 01H,@00H → Register 00H = 08H, register 01H = 0BFH
 OR 00H,#02H → Register 00H = 0AH

In the first example, if the working register R0 contains the value 15H and the register R1 the value 2AH, the statement "OR R0,R1" logical-ORs the R0 and R1 register contents and stores the result (3FH) in the destination register R0.

Other examples show the use of the logical OR instruction with the various addressing modes and formats.

POP – Pop From Stack

POP dst

Operation: dst ← @SP
 SP ← SP + 1

The contents of the location addressed by the stack pointer are loaded into the destination. The stack pointer is then incremented by one.

Flags: No flags affected.

Format:

		Bytes	Cycles	Opcode (Hex)	Addr Mode <u>dst</u>
opc	dst	2	10	50	R
			10	51	IR

Examples: Given: Register 00H = 01H, register 01H = 1BH, SPH (0D8H) = 00H, SPL (0D9H) = 0FBH, and stack register 0FBH = 55H:

POP 00H → Register 00H = 55H, SP = 00FCH

POP @00H → Register 00H = 01H, register 01H = 55H, SP = 00FCH

In the first example, the general register 00H contains the value 01H. The statement "POP 00H" loads the contents of the location 00FBH (55H) into the destination register 00H and then increments the stack pointer by one. The register 00H then contains the value 55H and the SP points to the location 00FCH.

POPUD – Pop User Stack (Decrementing)

POPUD dst,src

Operation: dst ← src
 IR ← IR – 1

This instruction is used for user-defined stacks in the register file. The contents of the register file location addressed by the user stack pointer are loaded into the destination. The user stack pointer is then decremented.

Flags: No flags are affected.

Format:

			Bytes	Cycles	Opcode (Hex)	Addr Mode <u>dst</u> <u>src</u>
opc	src	dst	3	10	92	R IR

Example: Given: Register 00H = 42H (user stack pointer register), register 42H = 6FH, and register 02H = 70H:

POPUD 02H,@00H → Register 00H = 41H, register 02H = 6FH, register 42H = 6FH

If the general register 00H contains the value 42H and the register 42H the value 6FH, the statement "POPUD 02H,@00H" loads the contents of the register 42H into the destination register 02H. The user stack pointer is then decremented by one, leaving the value 41H.

POPUI – Pop User Stack (Incrementing)

POPUI dst,src

Operation: dst ← src
IR ← IR + 1

The POPUI instruction is used for user-defined stacks in the register file. The contents of the register file location addressed by the user stack pointer are loaded into the destination. The user stack pointer is then incremented.

Flags: No flags are affected.

Format:

			Bytes	Cycles	Opcode (Hex)	Addr Mode <u>dst</u> <u>src</u>
opc	src	dst	3	10	93	R IR

Example: Given: Register 00H = 01H and register 01H = 70H:

POPUI 02H,@00H → Register 00H = 02H, register 01H = 70H, register 02H = 70H

If the general register 00H contains the value 01H and the register 01H the value 70H, the statement "POPUI 02H,@00H" loads the value 70H into the destination general register 02H. The user stack pointer (register 00H) is then incremented by one, changing its value from 01H to 02H.

PUSH – Push to Stack

PUSH src

Operation: $SP \leftarrow SP - 1$
 $@SP \leftarrow src$

A PUSH instruction decrements the stack pointer value and loads the contents of the source (src) into the location addressed by the decremented stack pointer. The operation then adds the new value to the top of the stack.

Flags: No flags are affected.

Format:

		Bytes	Cycles	Opcode (Hex)	Addr Mode <u>dst</u>
opc	src	2	10 (internal clock) 12 (external clock)	70	R
			12 (internal clock) 14 (external clock)	71	IR

Examples: Given: Register 40H = 4FH, register 4FH = 0AAH, SPH = 00H, and SPL = 00H:

PUSH 40H → Register 40H = 4FH, stack register 0FFH = 4FH,
 SPH = 0FFH, SPL = 0FFH

PUSH @40H → Register 40H = 4FH, register 4FH = 0AAH, stack register 0FFH = 0AAH, SPH = 0FFH, SPL = 0FFH

In the first example, if the stack pointer contains the value 0000H, and the general register 40H the value 4FH, the statement "PUSH 40H" decrements the stack pointer from 0000 to 0FFFFH. It then loads the contents of the register 40H into the location 0FFFFH and adds this new value to the top of the stack.

PUSHUD – Push User Stack (Decrementing)

PUSHUD dst,src

Operation: $IR \leftarrow IR - 1$

$dst \leftarrow src$

This instruction is used to address user-defined stacks in the register file. PUSHUD decrements the user stack pointer and loads the contents of the source into the register addressed by the decremented stack pointer.

Flags: No flags are affected.

Format:

			Bytes	Cycles	Opcode (Hex)	Addr Mode <u>dst</u> <u>src</u>
opc	dst	src	3	10	82	IR R

Example: Given: Register 00H = 03H, register 01H = 05H, and register 02H = 1AH:

PUSHUD @00H,01H → Register 00H = 02H, register 01H = 05H, register 02H = 05H

If the user stack pointer (register 00H, for example) contains the value 03H, the statement "PUSHUD @00H,01H" decrements the user stack pointer by one, leaving the value 02H. The 01H register value, 05H, is then loaded into the register addressed by the decremented user stack pointer.

PUSHUI – Push User Stack (Incrementing)

PUSHUI dst,src

Operation: $IR \leftarrow IR + 1$

$dst \leftarrow src$

This instruction is used for user-defined stacks in the register file. PUSHUI increments the user stack pointer and then loads the contents of the source into the register location addressed by the incremented user stack pointer.

Flags: No flags are affected.

Format:

			Bytes	Cycles	Opcode (Hex)	Addr Mode <u>dst</u> <u>src</u>
opc	dst	src	3	10	83	IR R

Example: Given: Register 00H = 03H, register 01H = 05H, and register 04H = 2AH:

PUSHUI @00H,01H → Register 00H = 04H, register 01H = 05H, register 04H = 05H

If the user stack pointer (register 00H, for example) contains the value 03H, the statement "PUSHUI @00H,01H" increments the user stack pointer by one, leaving the value 04H. The 01H register value, 05H, is then loaded into the location addressed by the incremented user stack pointer.

RCF – Reset Carry Flag

RCF RCF

Operation: $C \leftarrow 0$

The carry flag is cleared to logic zero, regardless of its previous value.

Flags: **C:** Cleared to "0".

No other flags are affected.

Format:

	Bytes	Cycles	Opcode (Hex)
opc	1	6	CF

Example: Given: C = "1" or "0":

The instruction RCF clears the carry flag (C) to logic zero.

RET – Return

RET

Operation: PC \leftarrow @SP
 SP \leftarrow SP + 2

The RET instruction is normally used to return to the previously executed procedure at the end of a procedure entered by a CALL instruction. The contents of the location addressed by the stack pointer are popped into the program counter. The next statement that is executed is the one that is addressed by the new program counter value.

Flags: No flags are affected.

Format:

	Bytes	Cycles	Opcode (Hex)
opc	1	14	AF

Example: Given: SP = 00FCH, (SP) = 101AH, and PC = 1234:

RET \rightarrow PC = 101AH, SP = 00FEH

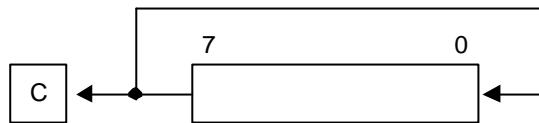
The statement "RET" pops the contents of the stack pointer location 00FCH (10H) into the high byte of the program counter. The stack pointer then pops the value in the location 00FEH (1AH) into the PC's low byte and the instruction at the location 101AH is executed. The stack pointer now points to the memory location 00FEH.

RL – Rotate Left

RL dst

Operation: $C \leftarrow \text{dst}(7)$
 $\text{dst}(0) \leftarrow \text{dst}(7)$
 $\text{dst}(n + 1) \leftarrow \text{dst}(n), n = 0-6$

The contents of the destination operand are rotated left one bit position. The initial value of bit 7 is moved to the bit zero (LSB) position and also replaces the carry flag.



Flags:

- C:** Set if the bit rotated from the most significant bit position (bit 7) was "1".
- Z:** Set if the result is "0"; cleared otherwise.
- S:** Set if the result bit 7 is set; cleared otherwise.
- V:** Set if arithmetic overflow occurred; cleared otherwise.
- D:** Unaffected.
- H:** Unaffected.

Format:

		Bytes	Cycles	Opcode (Hex)	Addr Mode
opc	dst	2	6	90	R
			6	91	IR

Examples: Given: Register 00H = 0AAH, register 01H = 02H and register 02H = 17H:

RL 00H → Register 00H = 55H, C = "1"
 RL @01H → Register 01H = 02H, register 02H = 2EH, C = "0"

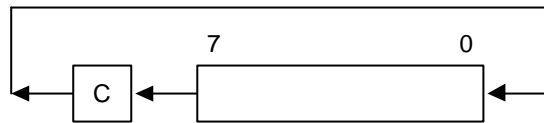
In the first example, if the general register 00H contains the value 0AAH (10101010B), the statement "RL 00H" rotates the 0AAH value left one bit position, leaving the new value 55H (01010101B) and setting the carry and overflow flags.

RLC – Rotate Left Through Carry

RLC dst

Operation: dst (0) ← C
 C ← dst (7)
 dst (n + 1) ← dst (n), n = 0–6

The contents of the destination operand with the carry flag are rotated left one bit position. The initial value of bit 7 replaces the carry flag (C); the initial value of the carry flag replaces bit zero.



Flags: **C:** Set if the bit rotated from the most significant bit position (bit 7) was "1".
 Z: Set if the result is "0"; cleared otherwise.
 S: Set if the result bit 7 is set; cleared otherwise.
 V: Set if arithmetic overflow occurred, that is, if the sign of the destination changed during rotation; cleared otherwise.
 D: Unaffected.
 H: Unaffected.

Format:

		Bytes	Cycles	Opcode (Hex)	Addr Mode
opc	dst	2	6	10	R
			6	11	IR

Examples: Given: Register 00H = 0AAH, register 01H = 02H, and register 02H = 17H, C = "0":

RLC 00H → Register 00H = 54H, C = "1"

RLC @01H → Register 01H = 02H, register 02H = 2EH, C = "0"

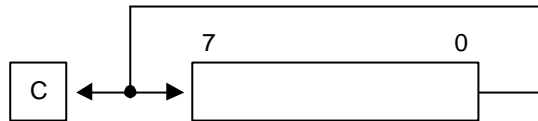
In the first example, if the general register 00H has the value 0AAH (10101010B), the statement "RLC 00H" rotates 0AAH one bit position to the left. The initial value of bit 7 sets the carry flag and the initial value of the C flag replaces bit zero of the register 00H, leaving the value 55H (01010101B). The MSB of the register 00H resets the carry flag to "1", setting the overflow flag.

RR – Rotate Right

RR dst

Operation: C ← dst (0)
 dst (7) ← dst (0)
 dst (n) ← dst (n + 1), n = 0–6

The contents of the destination operand are rotated right one bit position. The initial value of bit zero (LSB) is moved to bit 7 (MSB) and also replaces the carry flag (C).



- Flags:**
- C:** Set if the bit rotated from the least significant bit position (bit zero) was "1".
 - Z:** Set if the result is "0"; cleared otherwise.
 - S:** Set if the result bit 7 is set; cleared otherwise.
 - V:** Set if arithmetic overflow occurred, that is, if the sign of the destination changed during rotation; cleared otherwise.
 - D:** Unaffected.
 - H:** Unaffected.

Format:

		Bytes	Cycles	Opcode (Hex)	Addr Mode <u>dst</u>
opc	dst	2	6	E0	R
			6	E1	IR

Examples: Given: Register 00H = 31H, register 01H = 02H, and register 02H = 17H:

- RR 00H → Register 00H = 98H, C = "1"
 RR @01H → Register 01H = 02H, register 02H = 8BH, C = "1"

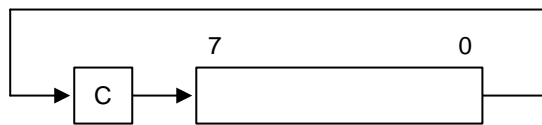
In the first example, if the general register 00H contains the value 31H (00110001B), the statement "RR 00H" rotates this value one bit position to the right. The initial value of bit zero is moved to bit 7, leaving the new value 98H (10011000B) in the destination register. The initial bit zero also resets the C flag to "1" and the sign flag and overflow flag are also set to "1".

RRC – Rotate Right Through Carry

RRC dst

Operation: dst (7) ← C
 C ← dst (0)
 dst (n) ← dst (n + 1), n = 0–6

The contents of the destination operand and the carry flag are rotated right one bit position. The initial value of bit zero (LSB) replaces the carry flag; the initial value of the carry flag replaces bit 7 (MSB).



Flags:

- C:** Set if the bit rotated from the least significant bit position (bit zero) was "1".
- Z:** Set if the result is "0" cleared otherwise.
- S:** Set if the result bit 7 is set; cleared otherwise.
- V:** Set if arithmetic overflow occurred, that is, if the sign of the destination changed during rotation; cleared otherwise.
- D:** Unaffected.
- H:** Unaffected.

Format:

		Bytes	Cycles	Opcode (Hex)	Addr Mode	
<table border="1" style="margin: auto;"> <tr> <td style="padding: 2px;">opc</td> <td style="padding: 2px;">dst</td> </tr> </table>	opc	dst	2	6	C0	R
	opc	dst				
		6	C1	IR		

Examples: Given: Register 00H = 55H, register 01H = 02H, register 02H = 17H, and C = "0":

RRC 00H → Register 00H = 2AH, C = "1"

RRC @01H → Register 01H = 02H, register 02H = 0BH, C = "1"

In the first example, if the general register 00H contains the value 55H (01010101B), the statement "RRC 00H" rotates this value one bit position to the right. The initial value of bit zero ("1") replaces the carry flag and the initial value of the C flag ("1") replaces bit 7. This leaves the new value 2AH (00101010B) in the destination register 00H. The sign flag and the overflow flag are both cleared to "0".

SB0 – Select Bank 0

SB0

Operation: BANK ← 0

The SB0 instruction clears the bank address flag in the FLAGS register (FLAGS.0) to logic zero, selecting bank 0 register addressing in the set 1 area of the register file.

Flags: No flags are affected.

Format:

	Bytes	Cycles	Opcode (Hex)
opc	1	6	4F

Example: The statement

SB0

clears FLAGS.0 to "0", selecting bank 0 register addressing.

SB1 – Select Bank 1

SB1

Operation: BANK ← 1

The SB1 instruction sets the bank address flag in the FLAGS register (FLAGS.0) to logic one, selecting bank 1 register addressing in the set 1 area of the register file. (Bank 1 is not implemented in some KS88-series microcontrollers.)

Flags: No flags are affected.

Format:

	Bytes	Cycles	Opcode (Hex)	
<table border="1"><tr><td>opc</td></tr></table>	opc	1	6	5F
opc				

Example: The statement

SB1

sets FLAGS.0 to "1", selecting bank 1 register addressing, if implemented.

SBC – Subtract with Carry

SBC dst,src

Operation: $dst \leftarrow dst - src - c$

The source operand, along with the current value of the carry flag, is subtracted from the destination operand and the result is stored in the destination. The contents of the source are unaffected. Subtraction is performed by adding the two's-complement of the source operand to the destination operand. In multiple precision arithmetic, this instruction permits the carry ("borrow") from the subtraction of the low-order operands to be subtracted from the subtraction of high-order operands.

- Flags:**
- C:** Set if a borrow occurred ($src > dst$); cleared otherwise.
 - Z:** Set if the result is "0"; cleared otherwise.
 - S:** Set if the result is negative; cleared otherwise.
 - V:** Set if arithmetic overflow occurred, that is, if the operands were of opposite sign and the sign of the result is the same as the sign of the source; cleared otherwise.
 - D:** Always set to "1".
 - H:** Cleared if there is a carry from the most significant bit of the low-order four bits of the result; set otherwise, indicating a "borrow".

Format:

			Bytes	Cycles	Opcode (Hex)	Addr Mode			
						<u>dst</u> <u>src</u>			
<table border="1" style="width: 100%; text-align: center;"> <tr> <td style="width: 33%;">opc</td> <td style="width: 66%;">dst src</td> </tr> </table>	opc	dst src			2	6	32	r r	
	opc	dst src							
				6	33	r lr			
<table border="1" style="width: 100%; text-align: center;"> <tr> <td style="width: 33%;">opc</td> <td style="width: 33%;">src</td> <td style="width: 33%;">dst</td> </tr> </table>	opc	src	dst			3	10	34	R R
	opc	src	dst						
				10	35	R IR			
<table border="1" style="width: 100%; text-align: center;"> <tr> <td style="width: 33%;">opc</td> <td style="width: 33%;">dst</td> <td style="width: 33%;">src</td> </tr> </table>	opc	dst	src			3	10	36	R IM
opc	dst	src							

Examples: Given: R1 = 10H, R2 = 03H, C = "1", register 01H = 20H, register 02H = 03H, and register 03H = 0AH:

- SBC R1,R2 → R1 = 0CH, R2 = 03H
- SBC R1,@R2 → R1 = 05H, R2 = 03H, register 03H = 0AH
- SBC 01H,02H → Register 01H = 1CH, register 02H = 03H
- SBC 01H,@02H → Register 01H = 15H, register 02H = 03H, register 03H = 0AH
- SBC 01H,#8AH → Register 01H = 95H; C, S, and V = "1"

In the first example, if the working register R1 contains the value 10H and the register R2 the value 03H, the statement "SBC R1,R2" subtracts the source value (03H) and the C flag value ("1") from the destination (10H) and then stores the result (0CH) in the register R1.

SCF – Set Carry Flag

SCF

Operation: $C \leftarrow 1$

The carry flag (C) is set to logic one, regardless of its previous value.

Flags: **C:** Set to "1".

No other flags are affected.

Format:

	Bytes	Cycles	Opcode (Hex)	
<table border="1"><tr><td>opc</td></tr></table>	opc	1	6	DF
opc				

Example: The statement

SCF

sets the carry flag to logic one.

SRA – Shift Right Arithmetic

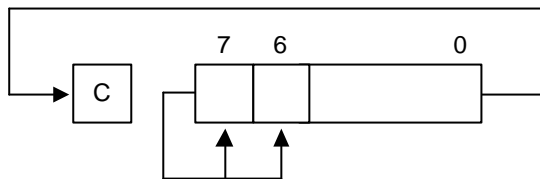
SRA dst

Operation: dst (7) ← dst (7)

 C ← dst (0)

 dst (n) ← dst (n + 1), n = 0–6

An arithmetic shift-right of one bit position is performed on the destination operand. Bit zero (the LSB) replaces the carry flag. The value of bit 7 (the sign bit) is unchanged and is shifted into the bit position 6.



- Flags:**
- C:** Set if the bit shifted from the LSB position (bit zero) was "1".
 - Z:** Set if the result is "0"; cleared otherwise.
 - S:** Set if the result is negative; cleared otherwise.
 - V:** Always cleared to "0".
 - D:** Unaffected.
 - H:** Unaffected.

Format:

		Bytes	Cycles	Opcode (Hex)	Addr Mode <u>dst</u>	
<table border="1" style="margin: auto;"> <tr> <td style="padding: 2px 10px;">opc</td> <td style="padding: 2px 10px;">dst</td> </tr> </table>	opc	dst	2	6	D0	R
	opc	dst				
		6	D1	IR		

Examples: Given: Register 00H = 9AH, register 02H = 03H, register 03H = 0BCH, and C = "1":

SRA 00H → Register 00H = 0CDH, C = "0"

SRA @02H → Register 02H = 03H, register 03H = 0DEH, C = "0"

In the first example, if the general register 00H contains the value 9AH (10011010B), the statement "SRA 00H" shifts the bit values in the register 00H right one bit position. Bit zero ("0") clears the C flag and bit 7 ("1") is then shifted into the bit 6 position (bit 7 remains unchanged). This leaves the value 0CDH (11001101B) in the destination register 00H.

STOP – Stop Operation

STOP

Operation:

The STOP instruction stops both the CPU clock and the system clock causing the microcontroller to enter Stop mode. During Stop mode, the contents of on-chip CPU registers, peripheral registers, and I/O port control and data registers are retained. Stop mode can be released only by an external reset operation. For the reset operation, the nRESET pin must be held to Low level until the required oscillation stabilization interval has elapsed.

Flags: No flags are affected.

Format:

	Bytes	Cycles	Opcode (Hex)	Addr Mode <u>dst</u> <u>src</u>
opc	1	3	7F	– –

Example: The statement
STOP
halts all microcontroller operations.

SUB – Subtract

SUB dst,src

Operation: $dst \leftarrow dst - src$

The source operand is subtracted from the destination operand and the result is stored in the destination. The contents of the source are unaffected. Subtraction is performed by adding the two's complement of the source operand to the destination operand.

Flags:

- C:** Set if a "borrow" occurred; cleared otherwise.
- Z:** Set if the result is "0"; cleared otherwise.
- S:** Set if the result is negative; cleared otherwise.
- V:** Set if arithmetic overflow occurred, that is, if the operands were of opposite signs and the sign of the result is of the same as the sign of the source operand; cleared otherwise.
- D:** Always set to "1".
- H:** Cleared if there is a carry from the most significant bit of the low-order four bits of the result; set otherwise, indicating a "borrow".

Format:

		Bytes	Cycles	Opcode (Hex)	Addr <u>dst</u>	Mode <u>src</u>
opc	dst src	2	6	22	r	r
			6	23	r	lr
opc	src	3	10	24	R	R
			10	25	R	IR
opc	dst	3	10	26	R	IM

Examples: Given: R1 = 12H, R2 = 03H, register 01H = 21H, register 02H = 03H, register 03H = 0AH:

SUB	R1,R2	→	R1 = 0FH, R2 = 03H
SUB	R1,@R2	→	R1 = 08H, R2 = 03H
SUB	01H,02H	→	Register 01H = 1EH, register 02H = 03H
SUB	01H,@02H	→	Register 01H = 17H, register 02H = 03H
SUB	01H,#90H	→	Register 01H = 91H; C, S, and V = "1"
SUB	01H,#65H	→	Register 01H = 0BCH; C and S = "1", V = "0"

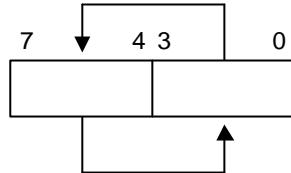
In the first example, if the working register R1 contains the value 12H and the register R2 contains the value 03H, the statement "SUB R1,R2" subtracts the source value (03H) from the destination value (12H), storing the result (0FH) in the destination register R1.

SWAP – Swap Nibbles

SWAP dst

Operation: dst (0 – 3) ↔ dst (4 – 7)

The contents of the lower four bits and the upper four bits of the destination operand are swapped.



- Flags:**
- C:** Undefined.
 - Z:** Set if the result is "0"; cleared otherwise.
 - S:** Set if the result bit 7 is set; cleared otherwise.
 - V:** Undefined.
 - D:** Unaffected.
 - H:** Unaffected.

Format:

		Bytes	Cycles	Opcode (Hex)	Addr Mode
opc	dst	2	8	F0	R
			8	F1	IR

Examples: Given: Register 00H = 3EH, register 02H = 03H, and register 03H = 0A4H:

SWAP 00H → Register 00H = 0E3H

SWAP @02H → Register 02H = 03H, register 03H = 4AH

In the first example, if the general register 00H contains the value 3EH (00111110B), the statement "SWAP 00H" swaps the lower and the upper four bits (nibbles) in the 00H register, leaving the value 0E3H (11100011B).



TCM – Test Complement under Mask

TCM dst,src

Operation: (NOT dst) AND src

This instruction tests selected bits in the destination operand for a logic one value. The bits to be tested are specified by setting a "1" bit in the corresponding position of the source operand (mask). The TCM statement complements the destination operand, which is then ANDed with the source mask. The zero (Z) flag can then be checked to determine the result. The destination and source operands are unaffected.

Flags:

- C:** Unaffected.
- Z:** Set if the result is "0"; cleared otherwise.
- S:** Set if the result bit 7 is set; cleared otherwise.
- V:** Always cleared to "0".
- D:** Unaffected.
- H:** Unaffected.

Format:

			Bytes	Cycles	Opcode (Hex)	Addr <u>dst</u>	Mode <u>src</u>			
<table border="1" style="display: inline-table; vertical-align: middle;"> <tr> <td style="padding: 2px 10px;">opc</td> <td style="padding: 2px 10px;">dst src</td> </tr> </table>	opc	dst src			2	6	62	r	r	
	opc	dst src								
				6	63	r	lr			
<table border="1" style="display: inline-table; vertical-align: middle;"> <tr> <td style="padding: 2px 10px;">opc</td> <td style="padding: 2px 10px;">src</td> <td style="padding: 2px 10px;">dst</td> </tr> </table>	opc	src	dst			3	10	64	R	R
	opc	src	dst							
				10	65	R	IR			
<table border="1" style="display: inline-table; vertical-align: middle;"> <tr> <td style="padding: 2px 10px;">opc</td> <td style="padding: 2px 10px;">dst</td> <td style="padding: 2px 10px;">src</td> </tr> </table>	opc	dst	src			3	10	66	R	IM
opc	dst	src								

Examples: Given: R0 = 0C7H, R1 = 02H, R2 = 12H, register 00H = 2BH, register 01H = 02H, and register 02H = 23H:

TCM	R0,R1	→	R0 = 0C7H, R1 = 02H, Z = "1"
TCM	R0,@R1	→	R0 = 0C7H, R1 = 02H, register 02H = 23H, Z = "0"
TCM	00H,01H	→	Register 00H = 2BH, register 01H = 02H, Z = "1"
TCM	00H,@01H	→	Register 00H = 2BH, register 01H = 02H, register 02H = 23H, Z = "1"
TCM	00H,#34	→	Register 00H = 2BH, Z = "0"

In the first example, if the working register R0 contains the value 0C7H (11000111B) and the register R1 the value 02H (00000010B), the statement "TCM R0,R1" tests bit one in the destination register for a "1" value. Because the mask value corresponds to the test bit, the Z flag is set to logic one and can be tested to determine the result of the TCM operation.

TM – Test under Mask

TM dst,src

Operation: dst AND src

This instruction tests selected bits in the destination operand for a logic zero value. The bits to be tested are specified by setting a "1" bit in the corresponding position of the source operand (mask), which is ANDed with the destination operand. The zero (Z) flag can then be checked to determine the result. The destination and source operands are unaffected.

Flags:
C: Unaffected.
Z: Set if the result is "0"; cleared otherwise.
S: Set if the result bit 7 is set; cleared otherwise.
V: Always reset to "0".
D: Unaffected.
H: Unaffected.

Format:

		Bytes	Cycles	Opcode (Hex)	Addr <u>dst</u>	Mode <u>src</u>			
<table border="1" style="display: inline-table; vertical-align: middle;"> <tr> <td style="padding: 2px 10px;">opc</td> <td style="padding: 2px 10px;">dst src</td> </tr> </table>	opc	dst src		2	6	72	r	r	
	opc	dst src							
			6	73	r	lr			
<table border="1" style="display: inline-table; vertical-align: middle;"> <tr> <td style="padding: 2px 10px;">opc</td> <td style="padding: 2px 10px;">src</td> <td style="padding: 2px 10px;">dst</td> </tr> </table>	opc	src	dst		3	10	74	R	R
	opc	src	dst						
			10	75	R	IR			
<table border="1" style="display: inline-table; vertical-align: middle;"> <tr> <td style="padding: 2px 10px;">opc</td> <td style="padding: 2px 10px;">dst</td> <td style="padding: 2px 10px;">src</td> </tr> </table>	opc	dst	src		3	10	76	R	IM
opc	dst	src							

Examples: Given: R0 = 0C7H, R1 = 02H, R2 = 18H, register 00H = 2BH, register 01H = 02H, and register 02H = 23H:

TM R0,R1 → R0 = 0C7H, R1 = 02H, Z = "0"
 TM R0,@R1 → R0 = 0C7H, R1 = 02H, register 02H = 23H, Z = "0"
 TM 00H,01H → Register 00H = 2BH, register 01H = 02H, Z = "0"
 TM 00H,@01H → Register 00H = 2BH, register 01H = 02H, register 02H = 23H, Z = "0"
 TM 00H,#54H → Register 00H = 2BH, Z = "1"

In the first example, if the working register R0 contains the value 0C7H (11000111B) and the register R1 the value 02H (00000010B), the statement "TM R0,R1" tests bit one in the destination register for a "0" value. Because the mask value does not match the test bit, the Z flag is cleared to logic zero and can be tested to determine the result of the TM operation.

WFI – Wait for Interrupt

WFI

Operation:

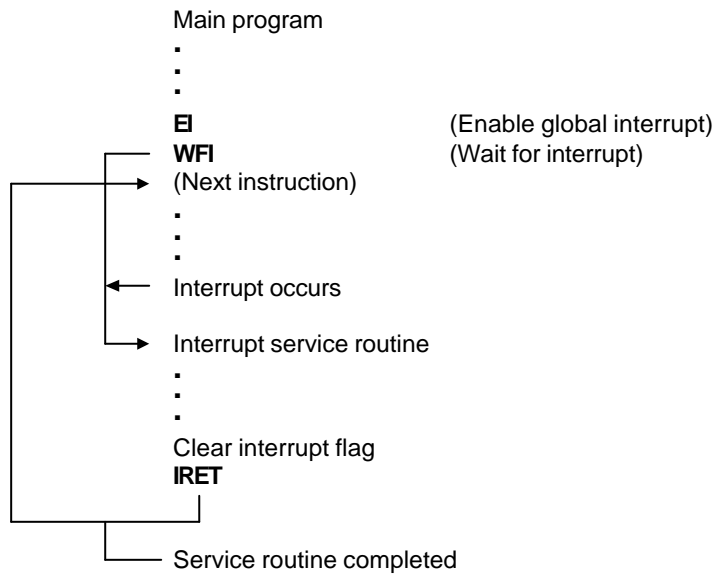
The CPU is effectively halted until an interrupt occurs, except in the case that DMA transfers can still take place during this wait state. The WFI status can be released by an internal interrupt, including a fast interrupt .

Flags: No flags are affected.

Format:

	Bytes	Cycles	Opcode (Hex)
opc	1	6n (n = 1, 2, 3, ...)	3F

Example: The following sample program structure shows the sequence of operations that follow a "WFI" statement:



XOR – Logical Exclusive OR

XOR dst,src

Operation: dst ← dst XOR src

The source operand is logically exclusive-ORed with the destination operand and the result is stored in the destination. The exclusive-OR operation results in a "1" bit being stored whenever the corresponding bits in the operands are different; otherwise, a "0" bit is stored.

Flags:
C: Unaffected.
Z: Set if the result is "0"; cleared otherwise.
S: Set if the result bit 7 is set; cleared otherwise.
V: Always reset to "0".
D: Unaffected.
H: Unaffected.

Format:

		Bytes	Cycles	Opcode (Hex)	Addr <u>dst</u>	Mode <u>src</u>			
<table border="1" style="display: inline-table; vertical-align: middle;"> <tr> <td style="padding: 2px 10px;">opc</td> <td style="padding: 2px 10px;">dst src</td> </tr> </table>	opc	dst src		2	6	B2	r	r	
	opc	dst src							
			6	B3	r	lr			
<table border="1" style="display: inline-table; vertical-align: middle;"> <tr> <td style="padding: 2px 10px;">opc</td> <td style="padding: 2px 10px;">src</td> <td style="padding: 2px 10px;">dst</td> </tr> </table>	opc	src	dst		3	10	B4	R	R
	opc	src	dst						
			10	B5	R	IR			
<table border="1" style="display: inline-table; vertical-align: middle;"> <tr> <td style="padding: 2px 10px;">opc</td> <td style="padding: 2px 10px;">dst</td> <td style="padding: 2px 10px;">src</td> </tr> </table>	opc	dst	src		3	10	B6	R	IM
opc	dst	src							

Examples: Given: R0 = 0C7H, R1 = 02H, R2 = 18H, register 00H = 2BH, register 01H = 02H, and register 02H = 23H:

XOR R0,R1 → R0 = 0C5H, R1 = 02H
 XOR R0,@R1 → R0 = 0E4H, R1 = 02H, register 02H = 23H
 XOR 00H,01H → Register 00H = 29H, register 01H = 02H
 XOR 00H,@01H → Register 00H = 08H, register 01H = 02H, register 02H = 23H
 XOR 00H,#54H → Register 00H = 7FH

In the first example, if the working register R0 contains the value 0C7H and the register R1 contains the value 02H, the statement "XOR R0,R1" logically exclusive-ORs the R1 value with the R0 value, storing the result (0C5H) in the destination register R0.

NOTES

7

CLOCK CIRCUITS

OVERVIEW

The clock frequency generated by an external crystal or ceramic resonator may range from 0.5 MHz to 8 MHz. The maximum CPU clock frequency is 8 MHz. The X_{IN} and X_{OUT} pins connect the external oscillation source to the on-chip clock circuit.

A separate external L-C resonator circuit generates a clock pulse for the on-screen display (OSD) block.

SYSTEM CLOCK CIRCUIT

The system clock circuit has the following components:

- External crystal or ceramic oscillation source
- Oscillator stop and wake-up functions
- Programmable frequency divider for the CPU clock (f_{OSC} divided by 1, 2, 8, or 16)
- Clock circuit control register, CLKCON

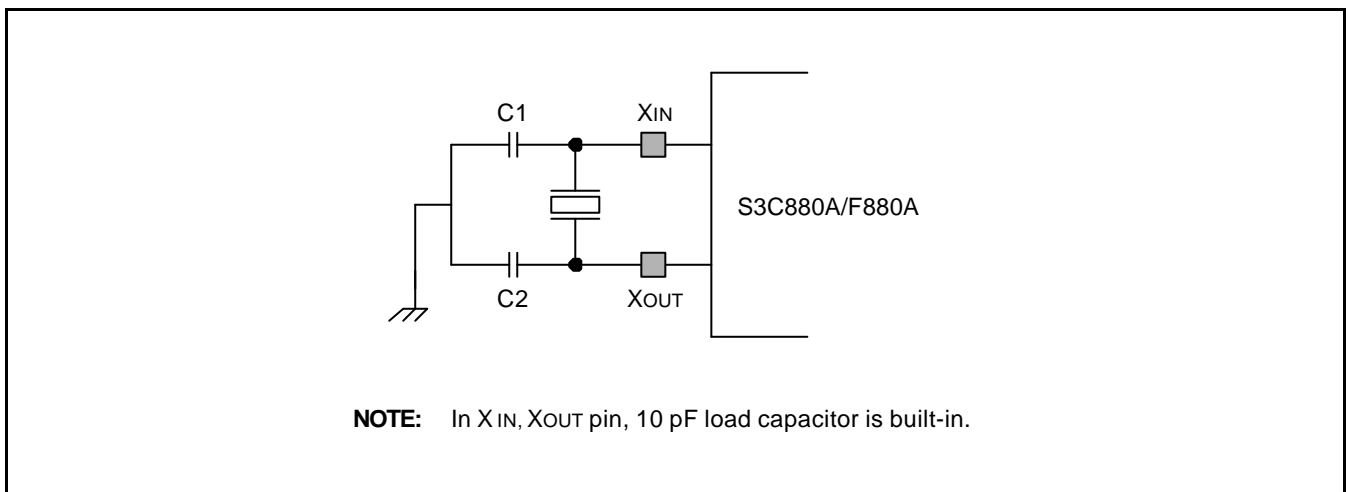


Figure 7-1. Main Oscillator Circuit (External Crystal or Ceramic Resonator)

CLOCK STATUS DURING POWER-DOWN MODES

The two power-down modes, Stop mode and Idle mode, affect system clock oscillation as follows:

- In Stop mode, the main oscillator is halted. Stop mode is released, and the oscillator started, by a reset operation or by an external interrupt (with RC-delay noise filter).
- In Idle mode, the internal clock signal is gated off to the CPU and to all peripherals except for the OSD block, Timer A counter, PWM, and capture (CAPA), which are inactive. Idle mode is released by a reset or by all interrupt.

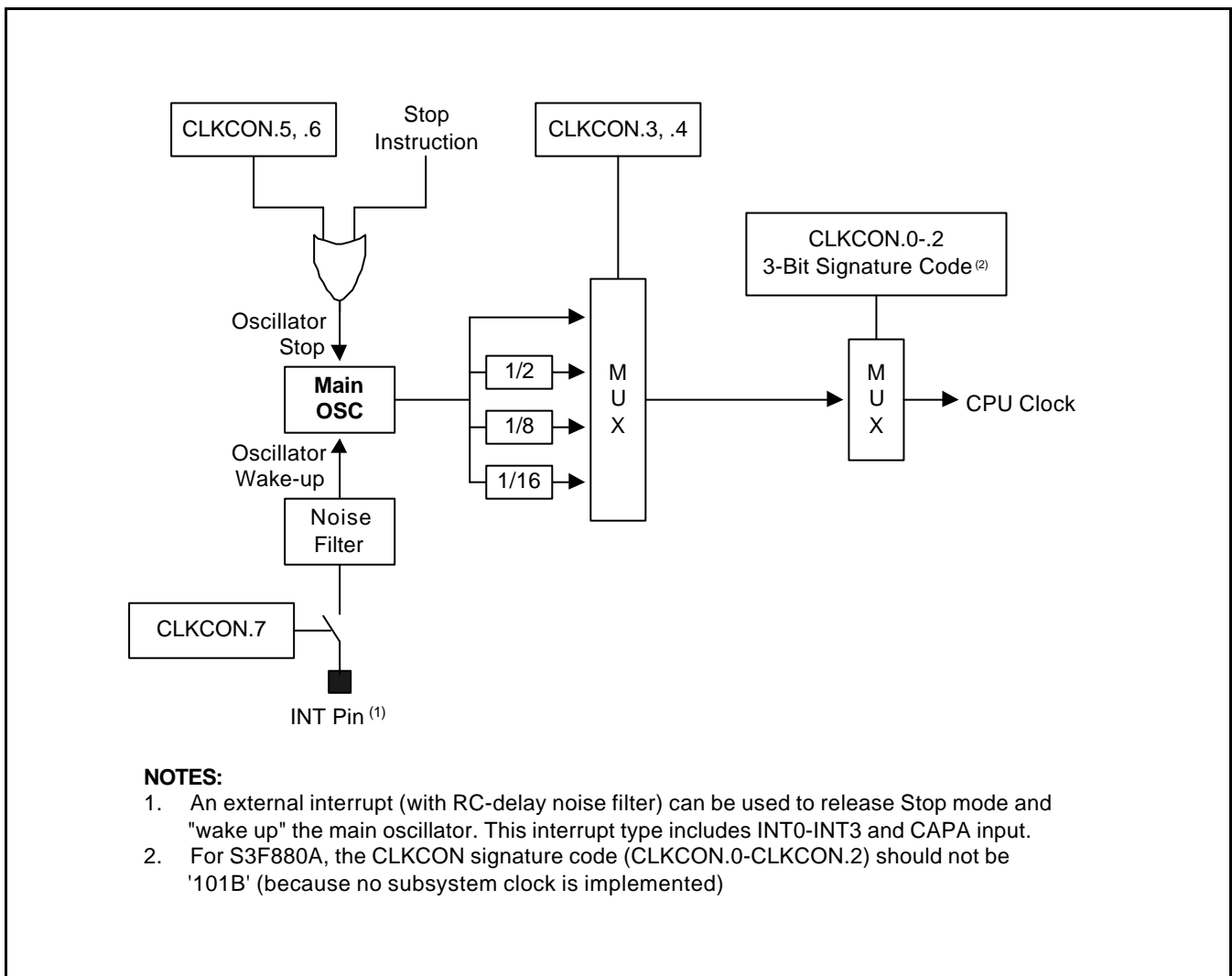


Figure 7-2. System Clock Circuit Diagram

SYSTEM CLOCK CONTROL REGISTER (CLKCON)

The system clock control register, CLKCON, is located in set 1 at address D4H. It is read/write addressable and has the following functions:

- Oscillator IRQ wake-up function enable/disable
- Main oscillator stop control
- Oscillator frequency divide-by value: non-divided, 2, 8, or 16
- System clock signal selection

The CLKCON register controls whether or not an external interrupt can be used to trigger a power-down mode release. (This is called the "IRQ wake-up" function.) The IRQ wake-up enable bit is CLKCON.7.

After a reset, the external interrupt oscillator wake-up bit is set to "1", the main oscillator is activated, and the $f_{OSC}/16$ (the slowest clock speed) is selected as the CPU clock. If necessary, you can then increase the CPU clock speed to f_{OSC} , $f_{OSC}/2$, or $f_{OSC}/8$.

For the S3C880A/F880A, the CLKCON.0–CLKCON.2 system clock signature code should be any value *other than* '101B'. (This setting is invalid because a subsystem clock is not implemented.) The reset value for the clock signature code is '000B'.

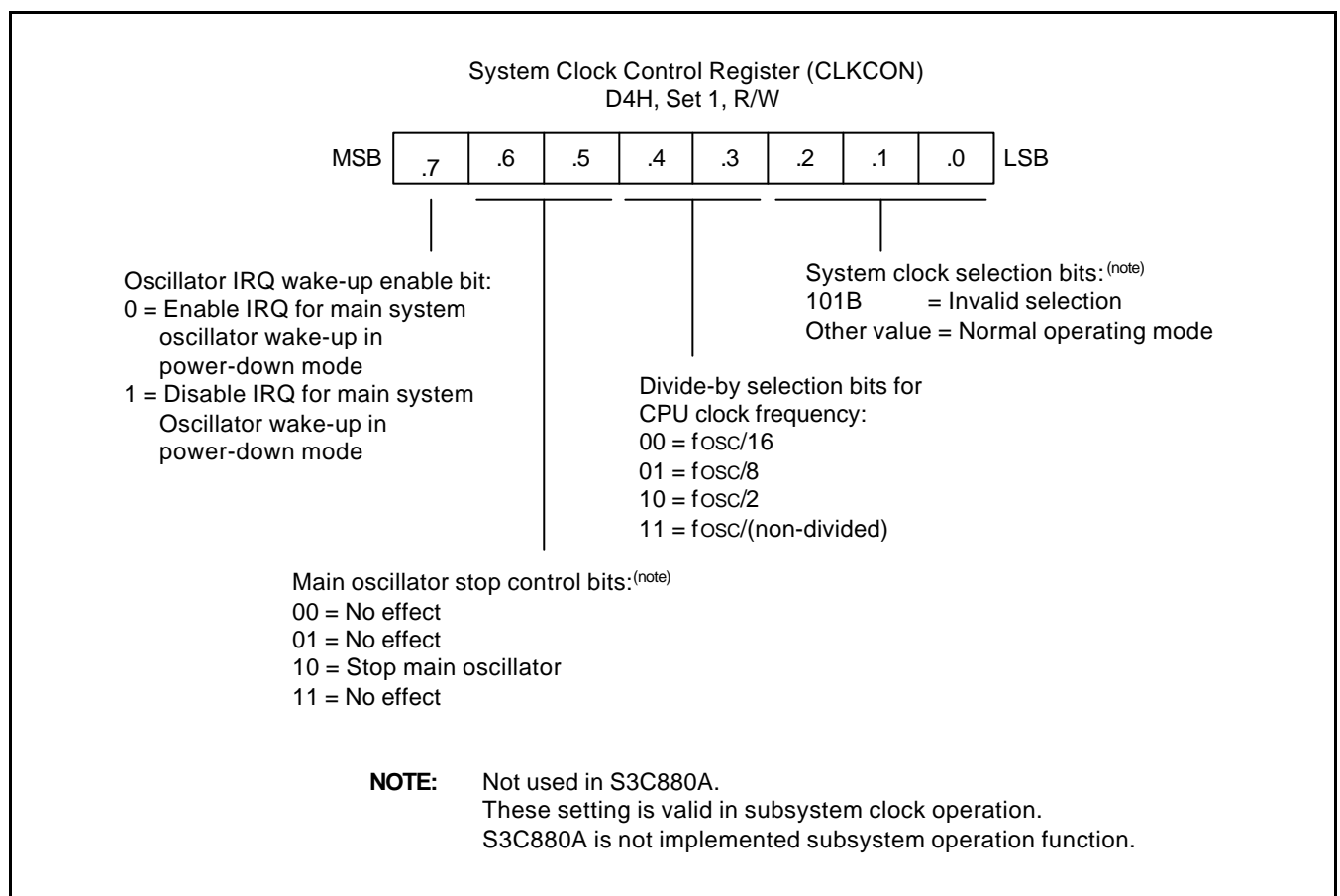


Figure 7-3. System Clock Control Register (CLKCON)

L-C Oscillator Circuit

The L-C oscillator circuit has the following components:

- External L-C oscillator with a 5-8 MHz frequency range
- Oscillator clock divider value (CHACON.4 and CHACON.5)
- OSC_{IN} and OSC_{OUT} pins
- On/off control bit (DSPCON.0)

Red-green-blue (RGB) color outputs, as well as display rates and positions, are determined by the L-C clock signal. This signal is scaled by the dot and column counter. The clock signal equals to the OSD oscillator clock divided by the clock divider value. The clock divider value is determined by the horizontal character size settings in the CHACON register.

The rate at which each new display line is generated is determined strictly by the H-sync input. The rate at which each new frame (screen) is generated is determined by the V-sync input.

NOTE: For stable on screen display operation, the CPU clock frequency should faster than L-C (OSD) clock.

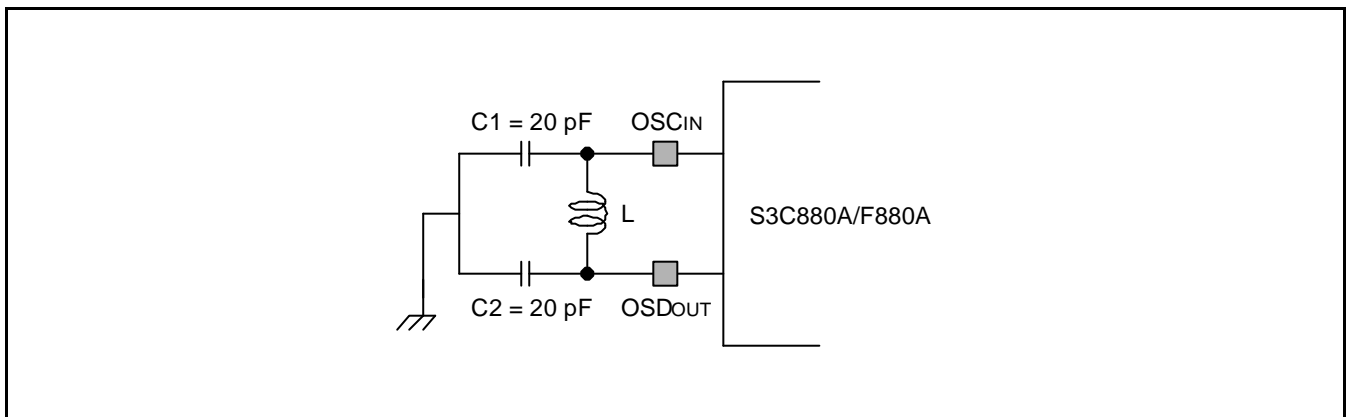
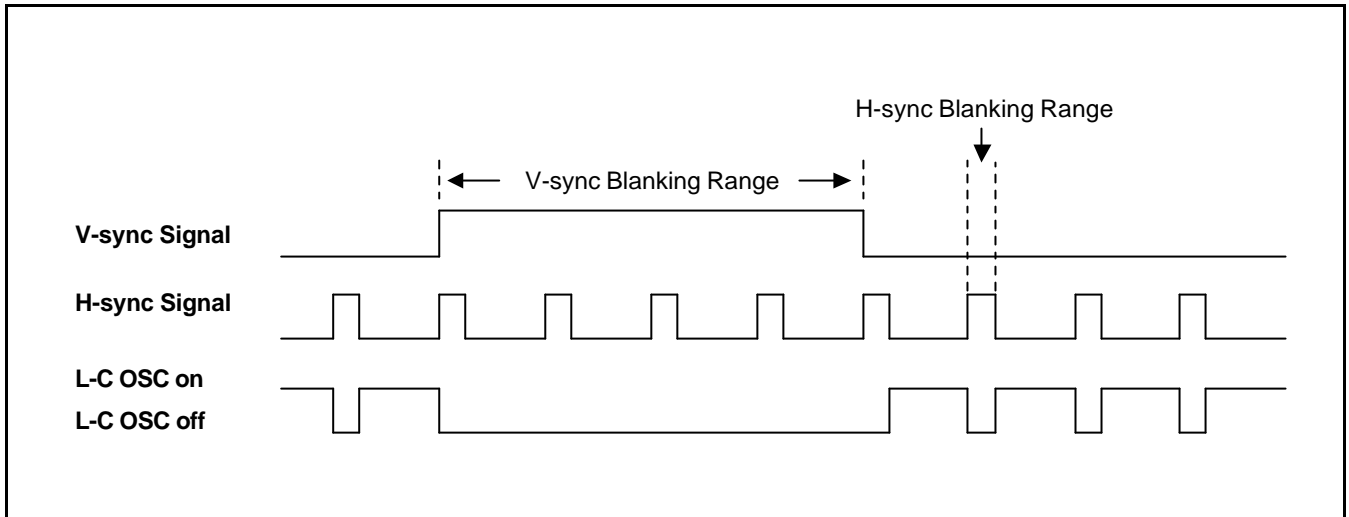


Figure 7-4. L-C Oscillator Circuit for OSD

L-C oscillator Operating Condition

To operate the LC oscillator, the following conditions must be satisfied.

- LC oscillator operation must be enabled by setting DSPCON.0 to "1".
- V-sync signal and H-sync signal must be input.
- LC oscillator must be operated except at the range of H-sync blanking and V-sync blanking.



RELATION BETWEEN L-C OSCILLATOR AND CPU CLOCK

For normal On Screen Display, L-C oscillator less than CPU Clock + 10 % is better. For 8 MHz CPU clock, an active L-C oscillator clock range is lower than 9MHz.

NOTES

8

nRESET and POWER-DOWN

SYSTEM nRESET

OVERVIEW

During a power-on reset, the voltage at V_{DD} is High level and the nRESET pin is forced to Low level. The nRESET signal is input through a Schmitt trigger circuit where it is then synchronized with the CPU clock. This brings the S3C880A/F880A into a normal operating status.

The nRESET pin must be held to Low level for a minimum time interval after the power supply comes within tolerance in order to allow time for internal CPU clock oscillation to stabilize. The minimum time required for oscillation stabilization for a reset is 1 millisecond.

When a reset occurs during the normal operation (that is, when V_{DD} and nRESET are High level), the nRESET pin is forced Low and the reset operation starts. All system and peripheral control registers are set to their default hardware reset values (see Table 8-1). In summary, the following sequence of events occurs during a reset operation:

- All interrupts are disabled.
- The watchdog function (basic timer) is enabled.
- Ports P0.0–P0.5, P1.6–P1.7 and P2 are set to input mode, and P0.6–P0.7, P1.0–P1.5 and P3, these ports set to N-channel open-drain output mode.
- Peripheral control and data registers are disabled and reset to their initial control values.
- The program counter is loaded with the ROM's reset address, 0100H.
- When the programmed oscillation stabilization time interval has elapsed, the instruction stored in the ROM location 0100H (and 0101H) is fetched and executed.

NOTE

You can program the duration of the oscillation stabilization interval by making the appropriate settings to the basic timer control register, BTCON, before entering Stop mode. Also, if you do not want to use the basic timer watchdog function (which causes a system reset if a basic timer counter overflow occurs), you can disable it by writing '1010B' to the upper nibble of BTCON.

HARDWARE RESET VALUES

Tables 8-1 through 8-3 list the reset values for CPU and system registers, peripheral control registers, and peripheral data registers after a reset operation. The following notation is used to represent reset values:

- A "1" or a "0" shows the reset bit value as logic one or logic zero, respectively.
- An 'x' means that the bit value is undefined after a reset.
- A dash ('-') means that the bit is either not used or not mapped.

Table 8-1. Set 1 Register Values after a Reset

Register Name	Mnemonic	Address		Bit Values After a Reset								
		Dec	Hex	7	6	5	4	3	2	1	0	
Timer 0 counter	T0CNT	208	D0H	0	0	0	0	0	0	0	0	0
Timer 0 data register	T0DATA	209	D1H	1	1	1	1	1	1	1	1	1
Timer 0 control register	T0CON	210	D2H	0	0	0	0	0	0	0	0	0
Basic timer control register	BTCON	211	D3H	0	0	0	0	0	0	0	0	0
Clock control register	CLKCON	212	D4H	0	0	0	0	0	0	0	0	0
System flags register	FLAGS	213	D5H	x	x	x	x	x	x	0	0	0
Register pointer 0	RP0	214	D6H	1	1	0	0	0	-	-	-	-
Register pointer 1	RP1	215	D7H	1	1	0	0	1	-	-	-	-
Stack pointer (high byte)	SPH	216	D8H	x	x	x	x	x	x	x	x	x
Stack pointer (low byte)	SPL	217	D9H	x	x	x	x	x	x	x	x	x
Instruction pointer (high byte)	IPH	218	DAH	x	x	x	x	x	x	x	x	x
Instruction pointer (low byte)	IPL	219	DBH	x	x	x	x	x	x	x	x	x
Interrupt request register	IRQ	220	DCH	0	0	-	0	0	0	0	0	0
Interrupt mask register	IMR	221	DDH	x	x	-	x	x	x	x	x	x
System mode register	SYM	222	DEH	0	-	0	x	x	x	0	0	0
Register page pointer	PP	223	DFH	0	0	0	0	0	0	0	0	0

NOTE: Although it is not used for the S3C880A/F880A, bit 5 of the SYM register should always be "0". If this bit is accidentally written to "1" by software, a system malfunction may occur.

Table 8-2. Set 1, Bank 0 Register Values after a Reset

Register Name	Mnemonic	Address		Bit Values After a Reset								
		Dec	Hex	7	6	5	4	3	2	1	0	
Port 0 data register	P0	224	E0H	0	0	0	0	0	0	0	0	0
Port 1 data register	P1	225	E1H	0	0	0	0	0	0	0	0	0
Port 2 data register	P2	226	E2H	0	0	0	0	0	0	0	0	0
Port 3 data register	P3	227	E3H	–	–	–	–	–	–	–	0	0
Port 0 control register (high byte)	P0CONH	228	E4H	1	1	1	1	0	0	0	0	0
Port 0 control register (low byte)	P0CONL	229	E5H	0	0	0	0	0	0	0	0	0
Port 1 control register (high byte)	P1CONH	230	E6H	0	0	0	0	1	1	1	1	1
Port 1 control register (low byte)	P1CONL	231	E7H	1	1	1	1	1	1	1	1	1
Port 2 control register (high byte)	P2CONH	232	E8H	0	0	0	0	0	0	0	0	0
Port 2 control register (low byte)	P2CONL	233	E9H	0	0	0	0	0	0	0	0	0
Location EAH in set 1, bank 0, are not mapped.												
Port 3 control register (low byte)	P3CONL	235	EBH	–	–	–	–	1	1	1	1	1
Locations ECH–EFH in set 1, bank 0, are not mapped.												
Timer A data register	TADATA	240	F0H	0	0	0	0	0	0	0	0	0
Location F1H in set 1, bank 0, are not mapped.												
Timer A control register	TACON	242	F2H	0	0	0	0	0	0	0	0	–
STOP control register	STCON	238	F3H	0	0	0	0	0	0	0	0	0
PWM0 data register (main byte)	PWM0	244	F4H	1	1	1	1	1	1	1	1	1
PWM0 data register (extension byte)	PWM0EX	245	F5H	0	0	0	0	0	0	–	–	–
PWM1 data register (main byte)	PWM1	246	F6H	1	1	1	1	1	1	1	1	1
PWM1 data register (extension byte)	PWM1EX	247	F7H	0	0	0	0	0	0	–	–	–
PWM control register	PWMCON	248	F8H	0	0	0	0	0	–	0	0	0
Capture A data register	CAPA	249	F9H	0	0	0	0	0	0	0	0	0
A/D converter control register	ADCON	250	FAH	–	–	0	0	x	0	0	0	0
A/D conversion data register	ADDATA	251	FBH	x	x	x	x	x	x	x	x	x
Location FCH in set 1, bank 0, are not mapped.												
Basic timer counter	BTCNT	253	FDH	0	0	0	0	0	0	0	0	0
External memory timing register	EMT	254	FEH	0	0	0	0	0	0	0	0	–
Interrupt priority register	IPR	255	FFH	x	x	–	x	x	x	x	x	x

Table 8-2. Set 1, Bank 1 Register Values after a Reset

Register Name	Mnemonic	Address		Bit Values After a Reset								
		Dec	Hex	7	6	5	4	3	2	1	0	
OSD fringe/border control register 1	OSDFRG1	224	E0H	0	0	0	0	0	0	0	0	0
OSD fringe/border control register 2	OSDFRG2	225	E1H	0	0	0	0	0	0	0	0	0
OSD smooth control register 1	OSDSMH1	226	E2H	0	0	0	0	0	0	0	0	0
OSD smooth control register 2	OSDSMH2	227	E3H	–	–	–	–	0	0	0	0	0
OSD space color control register	OSDCOL	236	E4H	–	–	–	–	0	0	0	0	0
OSD field control register	OSDFLD	237	E5H	–	–	x	0	0	1	1	0	0
OSD palette color mode R 1	OSDPLTR1	230	E6H	0	0	0	0	0	0	0	0	0
OSD palette color mode R 2	OSDPLTR2	231	E7H	1	1	1	1	1	1	1	1	1
OSD palette color mode G 1	OSDPLTG1	232	E8H	1	1	1	1	0	0	0	0	0
OSD palette color mode G 2	OSDPLTG2	233	E9H	1	1	1	1	0	0	0	0	0
OSD palette color mode B 1	OSDPLTB1	234	EAH	1	1	0	0	1	1	0	0	0
OSD palette color mode B 2	OSDPLTB2	235	EBH	1	1	0	0	1	1	0	0	0
Locations ECH–EFH in set 1, bank 1, are not mapped.												
OSD character size control register	CHACON	240	F0H	0	0	0	0	0	0	0	0	0
OSD fade control register	FADECON	241	F1H	0	0	0	0	0	0	0	0	0
OSD row position control register	ROWCON	242	F2H	0	0	0	0	0	0	0	0	0
OSD column position control register	CLMCON	243	F3H	0	0	0	0	0	0	0	0	0
OSD background color control register	COLCON	244	F4H	0	0	0	0	0	0	0	0	0
On-screen display control register	DSPCON	245	F5H	0	0	0	0	0	0	0	0	0
Halftone signal control register	HTCON	246	F6H	0	0	0	0	0	0	0	0	0
V-SYNC blank control register	VSBCON	252	F7H	–	–	–	0	1	0	0	0	1
PWM2 data register	PWM2	248	F8H	x	x	x	x	x	x	x	x	x
PWM3 data register	PWM3	249	F9H	x	x	x	x	x	x	x	x	x
PWM4 data register	PWM4	250	FAH	x	x	x	x	x	x	x	x	x
PWM5 data register	PWM5	251	FBH	x	x	x	x	x	x	x	x	x
OSD color buffer	COLBUF	247	FCH	–	–	–	x	x	x	x	x	x
Locations FDH–FFH in set 1, bank 1, are not mapped.												

Table 8-3. Page 1 Video RAM Register Values after a Reset

Register Name	Address	Bit Values After a Reset									
		7	6	5	4	3	2	1	0		
OSD video RAM	00H–FBH	x	x	x	x	x	x	x	x	x	x

POWER-DOWN MODES

STOP MODE

Stop mode is invoked by the instruction Stop (opcode 7FH) however Stop available state must be set by value "10100101b" in "STCON" register before Stop instruction is invoked. If Stop instruction (opcode 7FH) is executed in Stop not available state (STCON = other value except "10100101b") CPU go to RESET address. After Stop instruction is executed the state return to Stop not available state.

In Stop mode, the operation of the CPU and all peripherals is halted. That is, the on-chip main oscillator stops and the supply current is reduced to less than maximum 10 μ A. All system functions stop when the clock "freezes," but data stored in the internal register file is retained. Stop mode can be released in one of two ways: by a nRESET signal or by an external interrupt.

Using nRESET to Release Stop Mode

Stop mode is released when the nRESET signal goes inactive (High level) from active (Low level) state. All system and peripheral control registers are reset to their default values and the contents of all data registers are retained. A reset operation automatically selects a slow clock (1/16) because CLKCON.3 and CLKCON.4 are cleared to '00B'. After the programmed oscillation stabilization interval has elapsed, the CPU starts the system initialization routine by fetching the address stored in the ROM location 0100H.

Using an External Interrupt to Release Stop Mode

Two kinds of external interrupts with an RC-delay noise filter circuit can be used to release Stop mode. One external interrupts in the S3C880A/F880A interrupt structure that meet this requirement are INT0–INT3 (P1.0–P1.3) and the other one is V-sync input. Which interrupt you can use to release Stop mode in a given situation depends on the microcontroller's current internal operating mode.

Note that when Stop mode is released by an external interrupt, the current values in system and peripheral control registers are not changed. When you use an interrupt to release Stop mode, the CLKCON.3 and CLKCON.4 register values remain unchanged, and the currently selected clock value is used. If you use an external interrupt for Stop mode release, you can also program the duration of the oscillation stabilization interval. To do this, you must make the appropriate control and clock settings *before* entering Stop mode.

The external interrupt is serviced when a Stop mode release occurs. Following the IRET from the service routine, the instruction immediately following the one that initiated Stop mode is executed.

IDLE MODE

Idle mode is invoked by the instruction IDLE (opcode 6FH). In Idle mode, the CPU operations are halted while selected peripherals remain active. During Idle mode, the internal clock signal is gated off to the CPU and all peripherals except the OSD block timer A counter, PWM and capture (CAPA). Port pins retain the mode (input or output) they had at the time Idle mode was entered.

There are two ways to release Idle mode:

1. Execute a reset. All system and peripheral control registers are reset to their default values and the contents of all data registers are retained. The reset automatically selects a slow clock (1/16) because CLKCON.3 and CLKCON.4 are cleared to '00B'. If interrupts are masked, a reset is the only way to release Idle mode.
2. Activate any enabled interrupt, causing Idle mode to be released. When you use an interrupt to release Idle mode, the CLKCON.3 and CLKCON.4 register values remain unchanged, and the currently selected clock value is used. The interrupt is then serviced. When the return-from-interrupt (IRET) occurs, the instruction immediately following the one that initiated Idle mode is executed.

NOTE

Only external interrupts can be used to release Stop mode. To release Idle mode, you can use either type of interrupt (internal or external).

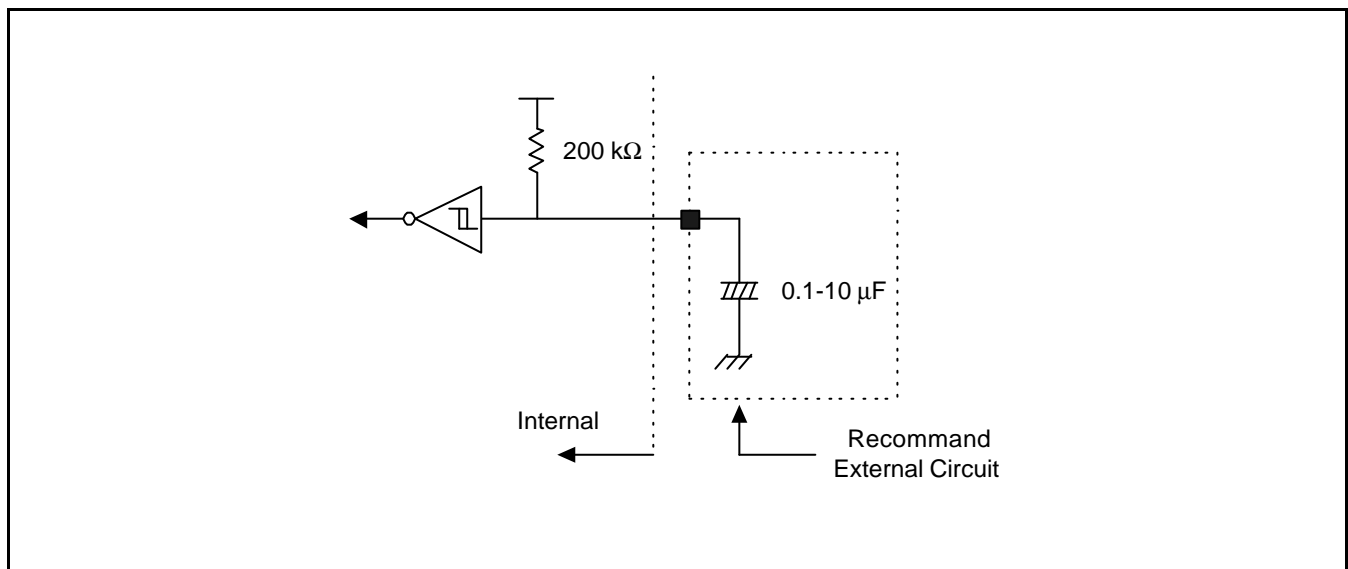


Figure 8-1. Reset Circuit Application

PROGRAMMING TIP — Enter to Stop Mode

The following sample program shows you recommended entering Stop mode for the S3C880A/F880A.

```
•  
•  
•  
ld    STCON, #10100101b    ; After this instruction is executed  
                                ; Stop instruction is available  
STOP  
NOP                                ; NOP need more than three after STOP instruction  
NOP  
NOP  
•  
•  
•
```

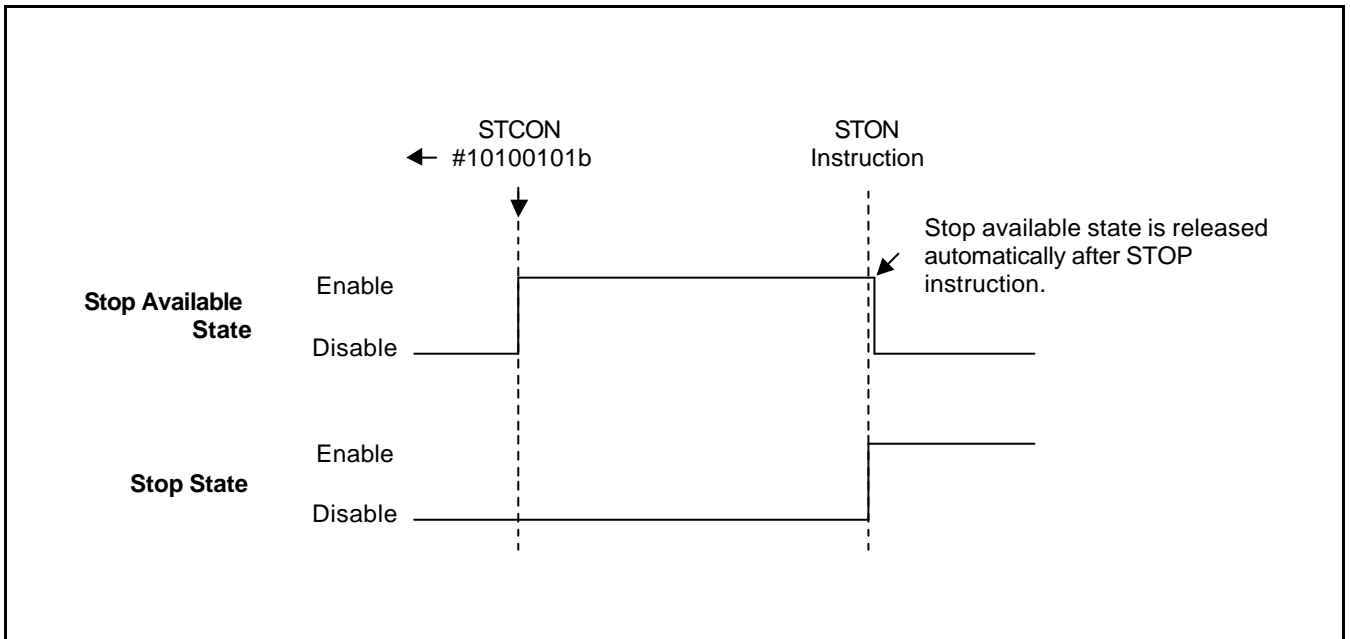



Figure 8-2. Stop State Timing Diagram

 **PROGRAMMING TIP — Initial Settings for Address Space, Vectors, and Peripherals**

The following sample program shows you recommended initial settings for the S3C880A/F880A address space, interrupt vectors, and peripheral functions. Program comments guide you through the required steps:

```

•
•
•
OSD_REG    EQU    0C8H        ; OSD working register area
OSD_FLG    EQU    8
DSP_TYP    EQU    9
VRAMAD     EQU    0CH
WORK1      EQU    0BH        ; General-purpose area
WORK2      EQU    0AH        ; General-purpose area
REMOCON    EQU    3FH        ; CAPA data save register
•
•
•
ORG        02H
DW        CAPA_INT;          Capture A interrupt

ORG        0BEH
DW        TIMERA_INT        ; Timer A interrupt

ORG        0C0H
DW        P10_INT           ; P1.0 external interrupt
DW        P11_INT           ; P1.1 external interrupt
DW        OSD_ROW_INT       ; OSD ROW interrupt
DW        P12_INT           ; P1.2 external interrupt
DW        P13_INT           ; P1.3 external interrupt

ORG        0D4H
DW        V_SYNC_INT        ; V-sync interrupt

ORG        0FCH
DW        TIMER0_INT        ; Timer 0 interrupt

ORG        0100H

START      DI                ; Disable all interrupts
           LD        BTCON,#0AAH ; Disable the watchdog timer
           LD        CLKCON,#98H ; Non-divided clock
           CLR       SYM        ; Disable global and fast interrupts
           CLR       SPL        ; Stack pointer low byte ← "0"
           ; Stack area will start at 0FFH
           SB1         ; Select bank 1

```

(Continued on next page)

👉 **PROGRAMMING TIP — Initial Settings for Address Space, Vectors, and Peripherals (Continued)**

```

; Enable OSD ROW interrupt
LD      HTCON,#2AH      ; Enable V-sync interrupt
LD      DSPCON,#0A0H   ; Disable OSD logic
SB0     ; Select bank 0
LD      PWMCON,#0E9H   ; Prescaler ← 4
; Enable PWM counter
; Enable capture A interrupt
LD      IPR,#0AEH      ; Interrupt priority settings
; IRQ6 > 7 > 3 > 2 > 0 > 1
LD      IMR,#0CCH      ; Enable level 2, 3, 6, and 7 interrupts
LD      P0CONH,#00H    ; Input mode
LD      P0CONL,#0FFH   ; Push-pull output mode
LD      P1CONH,#0FFH   ; Output mode
LD      P1CONL,#00H    ; Input mode
LD      P2CONH,#00H    ; Input mode
LD      P2CONL,#00H    ; Input mode
LD      P3CONL,#00H    ; Input mode

LD      TACON,#54H     ; Prescaler ← 6
; Clock source ← CPU clock / 1000
; Enable timer A interrupt
; Interval timer mode
LD      TADATA,#03H    ; 4-millisecond interrupt

EI

MAIN    NOP
        NOP
        .
        .
        .
        NOP
        JP      T,MAIN   ; Jump MAIN

CAPA_INT:
; CAPA interrupt service
PUSH    PP             ; Save page pointer to stack
PUSH    RP0            ; Save register pointer 0 to stack
PUSH    RP1            ; Save register pointer 1 to stack
        .
        .
        .
LD      REMOCON,CAPA   ; REMOCON ← CAPA data
POP     RP1            ; Restore register pointer 1 value
POP     RP0            ; Restore register pointer 0 value
POP     PP             ; Restore page pointer value
IRET    ; Return from interrupt service routine

```

(Continued on next page)

 **PROGRAMMING TIP — Initial Settings for Address Space, Vectors, and Peripherals (Continued)**

```

TIMERA_INT      PUSH      PP          ; TIMER_A interrupt service
                PUSH      RP0
                PUSH      RP1
                .
                .
                .
                LD        TACON, #54H ; Clear pending bit
                POP       RP1
                POP       RP0
                POP       PP
                IRET          ; Return from interrupt service routine

V_SYNC_INT      PUSH      PP          ; V_SYNC interrupt service
                PUSH      RP0
                PUSH      RP1
                .
                .
                .
                SB1
                LD        HTCON, #3AH ; Clear pending bit
                POP       RP1
                POP       RP0
                POP       PP
                IRET          ; Return from interrupt service routine

OSD_ROW_INT:
                PUSH      PP
                PUSH      RP0
                PUSH      RP1
                .
                .
                .
                SB1
                LD        HTCON, #2BH ; Clear pending bit
                POP       RP1
                POP       RP0
                POP       PP
                IRET

P10_INT:        ; P1.0 external interrupt
P11_INT:        ; P1.1 external interrupt
P12_INT:        ; P1.2 external interrupt
P13_INT:        ; P1.3 external interrupt
TIMER0_INT:    ; Timer 0 interrupt
                IRET          ; Return from interrupt service routine

```

9

I/O PORTS

OVERVIEW

The S3C880A/F880A and the S3C880A/F880A microcontrollers have four I/O ports with a total of 26 pins. Up to 10 pins can be configured as n-channel open-drain outputs. Of these 10 open-drain pins, 6 pins can withstand loads of up to 6 volts and 4 pins can withstand loads of up to 5 volts.

The CPU accesses ports by directly writing or reading port registers. No special I/O instructions are required. Table 9-1 gives you a summary of port functions:

Table 9-1. S3C880A/F880A Port Configuration Overview

Port	Configuration Options	Programmability
0	General I/O port, configurable for digital input or push-pull output. Pins P0.6–P0.7 are multiplexed to support alternative function.	Bit programmable
1	General I/O port, configurable for digital input or n-channel open-drain output. Pins 1.0–P1.5 can withstand up to 6-volt loads. Pins 1.0–P1.3 are multiplexed to support alternative functions.	Bit programmable
2	General I/O port, configurable for n-channel open-drain or push-pull output mode by software. Pins can withstand up to 5-volt loads. Each pin has an alternative function.	Bit programmable
3	General 2-bit I/O port, configurable for digital input or n-channel open-drain output. Pins can withstand up to 5 V. P3.0–P3.1 can be alternately used as external interrupt inputs ADC0–ADC1.	Bit programmable

PORT DATA REGISTERS

Data registers for ports 0–3 have the structure shown in Figure 9-1. Table 9-2 gives you an overview of the port data register locations:

Table 9-2. Port Data Register Summary

Register Name	Mnemonic	Decimal	Hex	Location	R/W
Port 0 data register	P0	224	E0H	Set 1, bank 0	R/W
Port 1 data register	P1	225	E1H	Set 1, bank 0	R/W
Port 2 data register	P2	226	E2H	Set 1, bank 0	R/W
Port 3 data register	P3	227	E3H	Set 1, bank 0	R/W

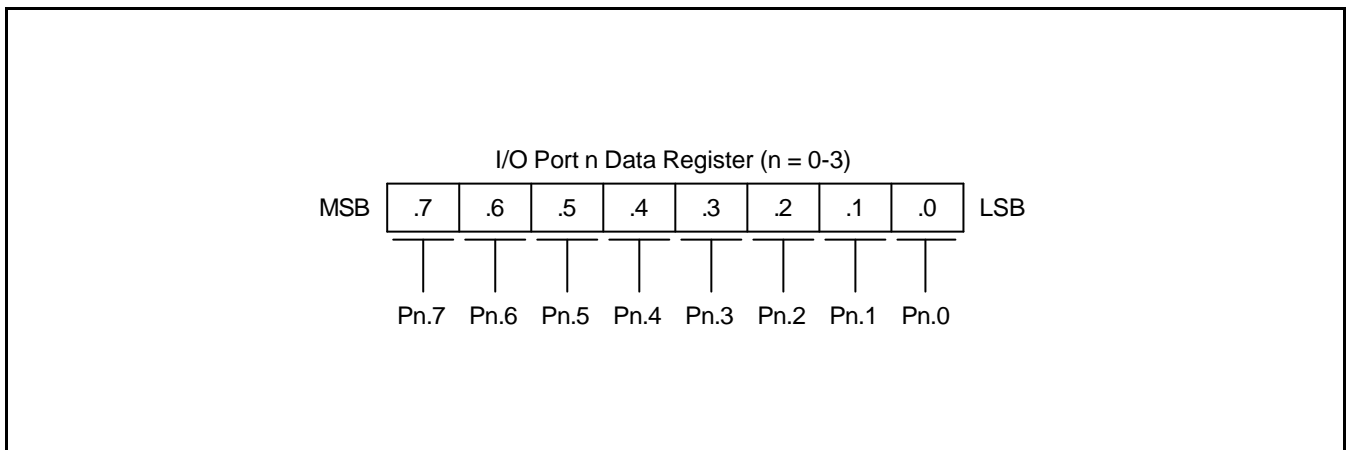


Figure 9-1. Port Data Register Format

Port 0

Port 0 is a bit-programmable general I/O port. Port 0 is accessed directly by writing or reading the port 0 data register, P0 (E0H, set 1, bank 0).

The port 0 pins are configured by bit-pair settings in the P0CONH and P0CONL registers. P0CONH controls I/O for the upper byte pins and P0CONL controls I/O for the lower byte pins.

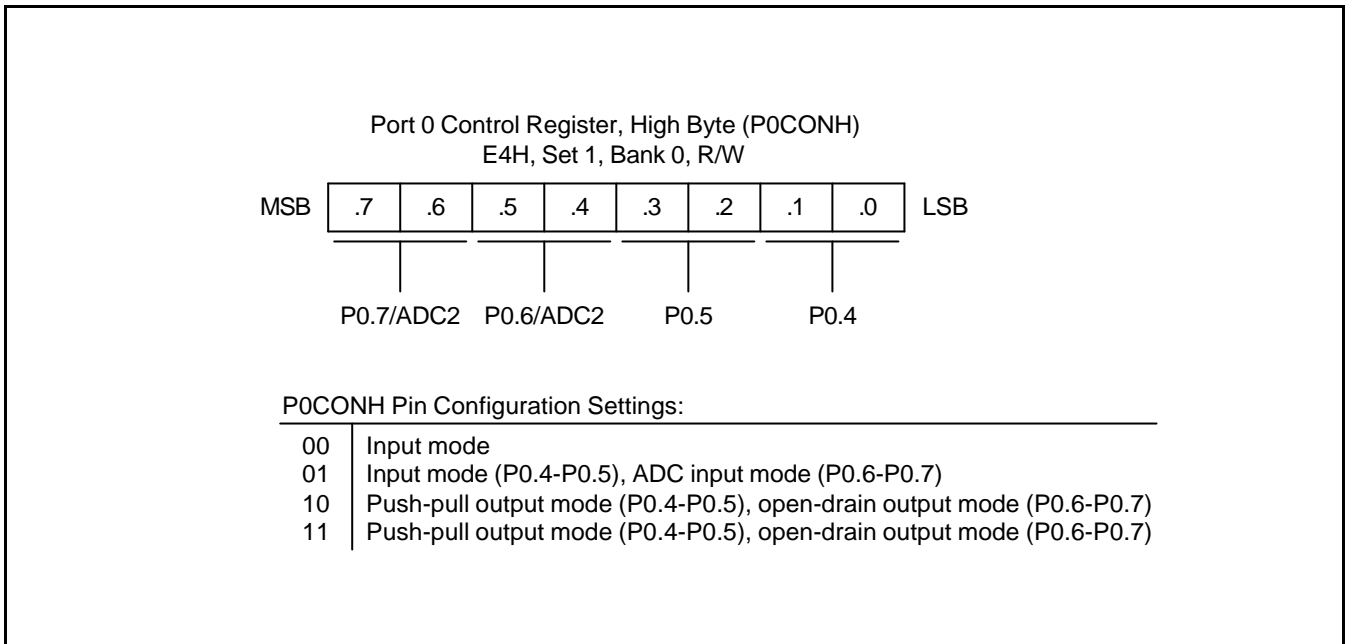


Figure 9-2. Port 0 High-Byte Control Register (P0CONH)

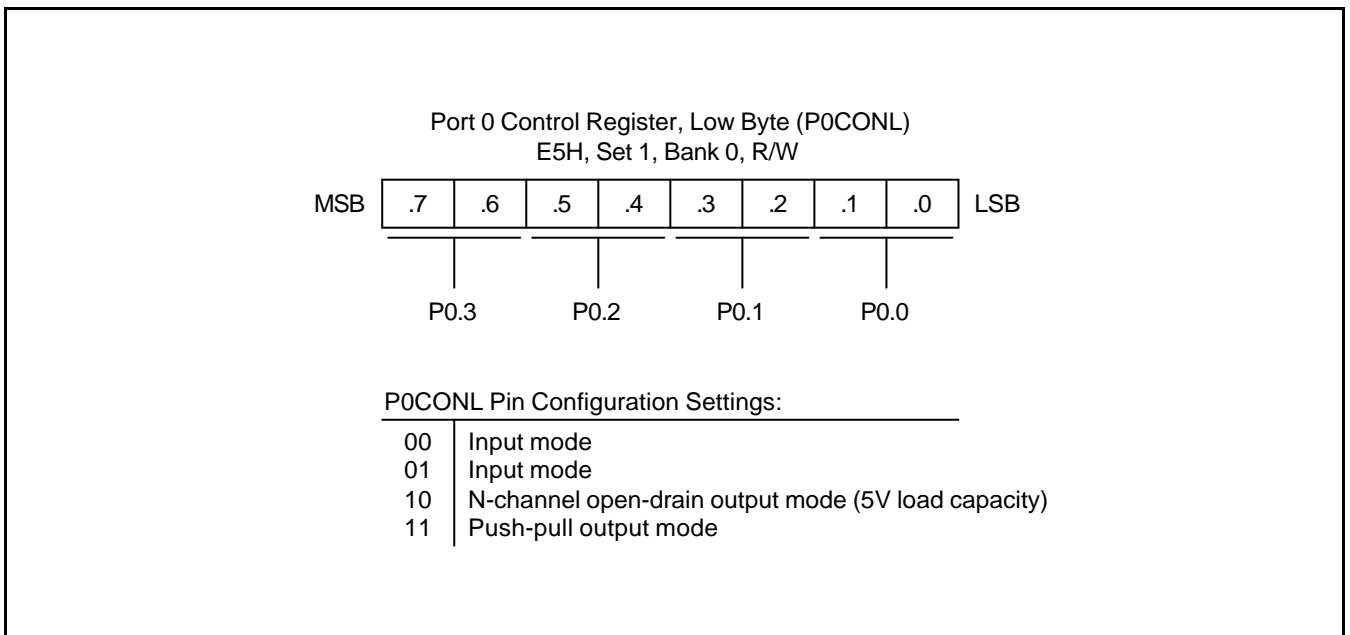


Figure 9-3. Port 0 Low-Byte Control Register (P0CONL)

PORT 1

Port 1 is a bit-programmable general I/O port. Port 1 is accessed directly by writing or reading the port 1 data register, P1 (E1H, set 1, bank 0). The upper byte (P1.4–P1.7) and the lower byte (P1.0–P1.3) are controlled by the P1CONH and P1CONL registers, respectively. P1CONH is located at E6H in set 1, bank 0 and P1CONL is located at E7H in set 1, bank 0.

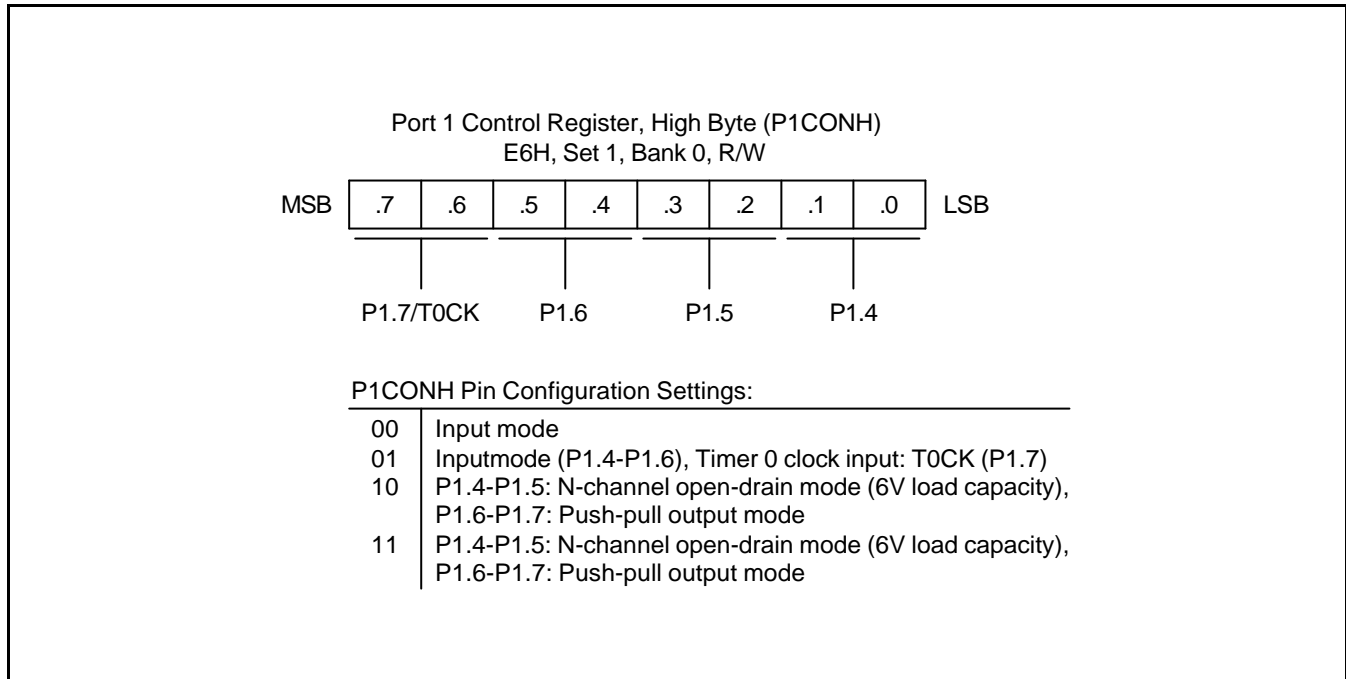


Figure 9-4. Port 1 High-Byte Control Register (P1CONH)

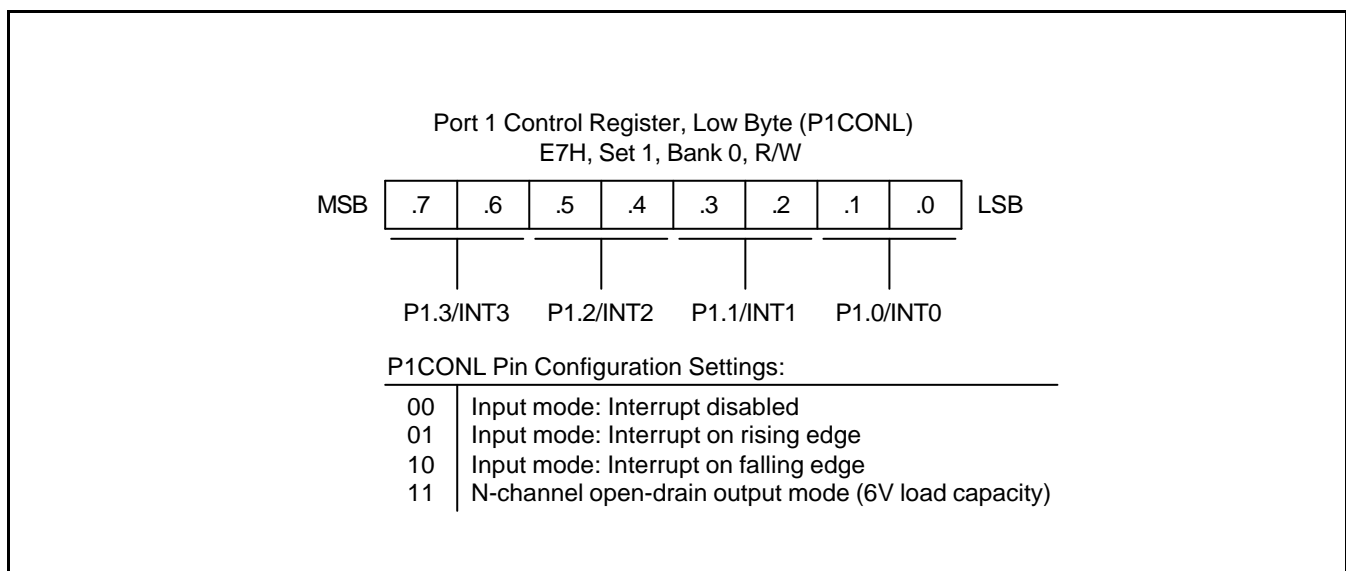


Figure 9-5. Port 1 Low-Byte Control Register (P1CONL)

PORT 2

Port 2 is a bit-programmable general I/O port. Port 2 is accessed directly by writing or reading the port 2 data register, P2 (E2H, set 1, bank 0). The upper byte (P2.4–P2.7) and the lower byte (P2.0–P2.3) are controlled by the P2CONH and P2CONL registers, respectively.

A reset clears the port 2 control registers to '00H', configuring the port 2 pins to normal input mode (P2.0–P2.3) and input mode (2.4–P2.7). You use P2CONH and P2CONL register settings to configure individual port 2 pins:

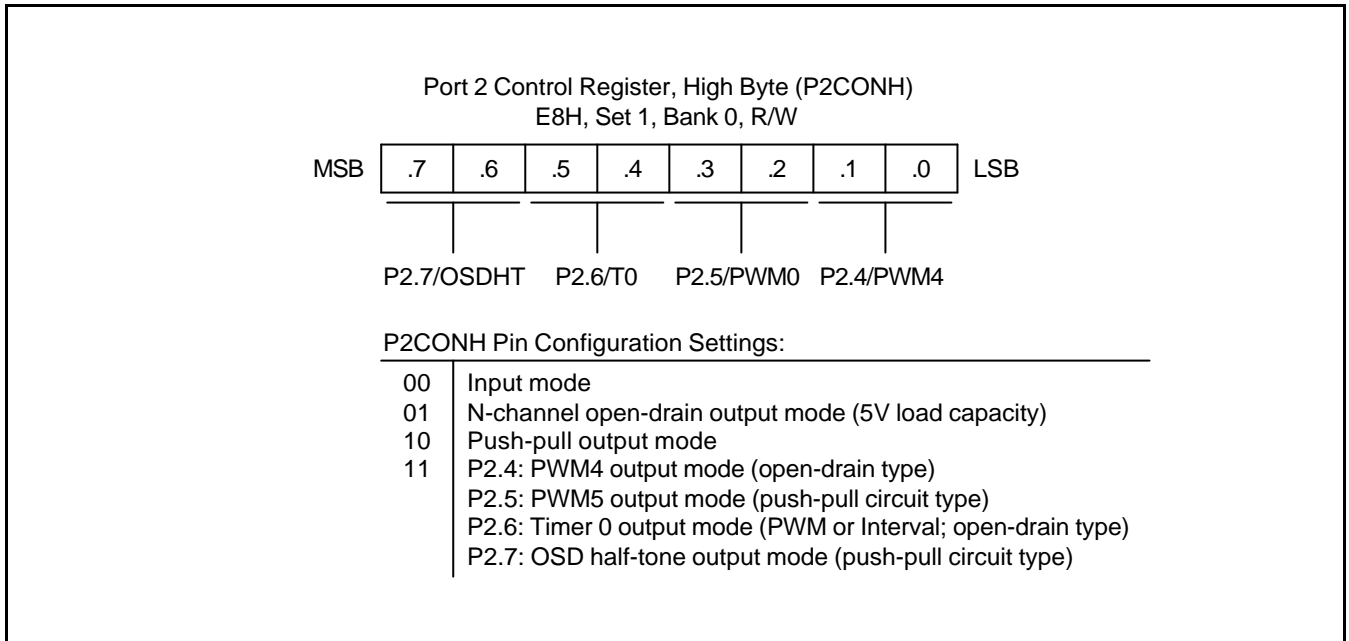


Figure 9-6. Port 2 High-Byte Control Register (P2CONH)

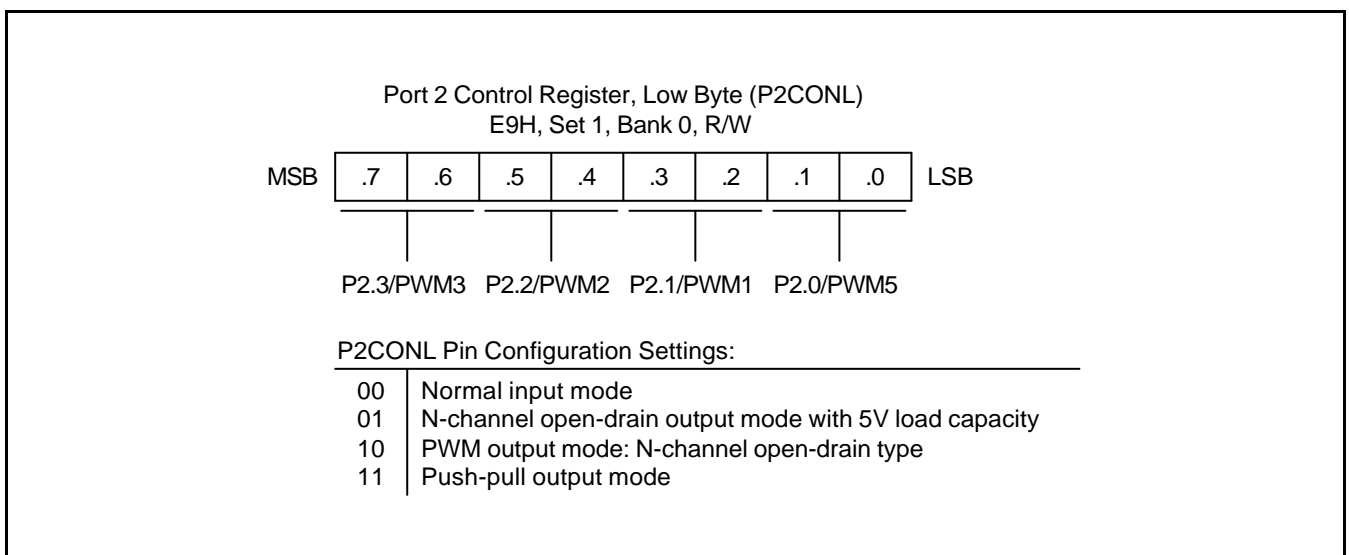


Figure 9-7. Port 2 Low-Byte Control Register (P2CONL)

PORT 3

Port 3 is a bit-programmable general I/O port. Only two bits are used. Port 3 is accessed directly by writing or reading the port 3 data register, P3 (E3H, set 1, bank 0).

A reset operation sets the P3 data register to '00H', and the port 3 control register to '0FH', configuring the port 3 pins to output (open-drain) mode.

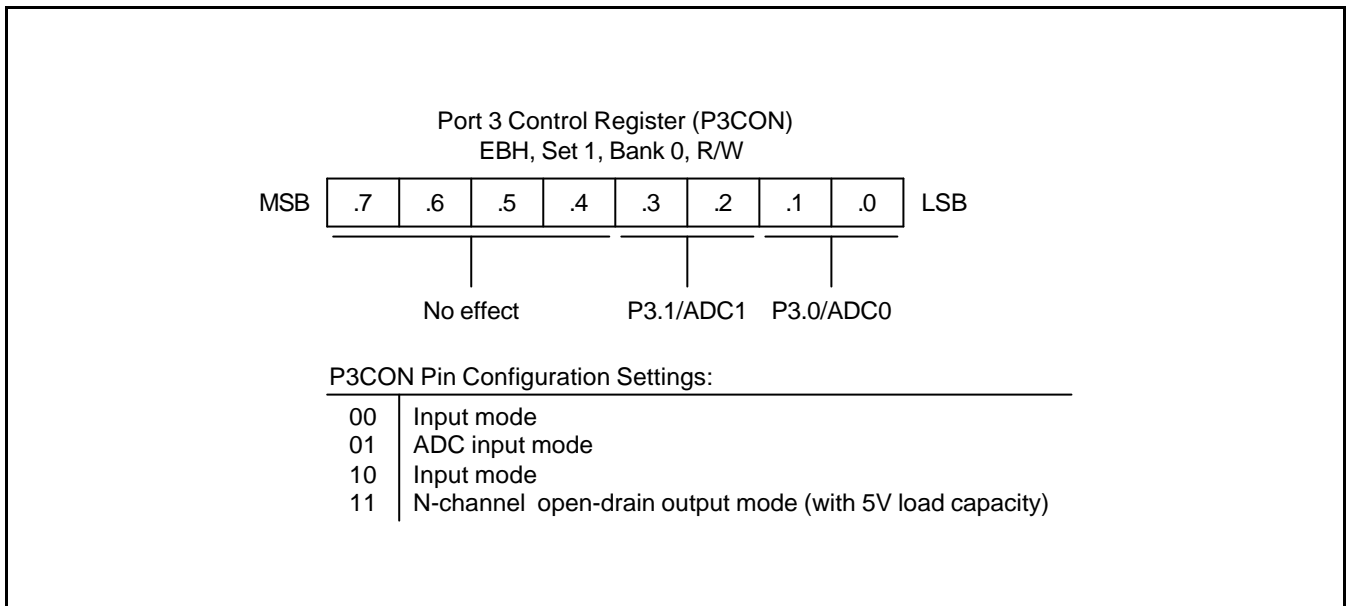


Figure 9-8. Port 3 Control Register (P3CON)

 **PROGRAMMING TIP — Configuring I/O Port Pins to Specification**

The following sample program shows you how to configure the S3C880A/F880A I/O ports to specification. The following parameters are given for ports 0, 1, 2, and 3:

- Set P0.0 and P0.1 to input mode
- Set P0.2 and P0.3 to output mode
- Set P0.4 and P0.5 to input mode
- Set P0.6 and P0.7 to open-drain output mode
- Set P1.0–P1.1 to interrupt rising edge mode
- Set P1.2–1.5 to open-drain output mode
- Set P1.6– P1.7 to push-pull output mode
- Set P2.0 and P2.1 to open-drain output mode
- Set P2.2–P2.4 to input mode
- Set P2.6–2.7 to push-pull output mode
- Set P2.5 to PWM0 output mode
- Set P3.0–P3.1 to ADC input mode

```

•
•
•
SB0                ; Select bank 0

LD      P0CONH,#0F0H ; P0.4, P0.5 ← Input mode
                          ; P0.6, P0.7 ← Open-drain output mode
LD      P0CONL,#0F0H ; P0.0, P0.1 ← Input mode
                          ; P0.2, P0.3 ← Output mode

LD      P1CONH,#0FFH ; P1.6–1.7 ← Push-pull output mode
                          ; P1.2–1.5 ← Open-drain output mode
LD      P1CONL,#0F5H ; P1.0, P1.1 ← Interrupt rising edge mode

LD      P2CONH,#0ACH ; P2.4 ← Input mode
                          ; P2.6, 2.7 ← Push-pull output mode
                          ; P2.5 ← PWM0 output mode
LD      P2CONL,#05H  ; P2.0, P2.1 ← Open-drain output mode
                          ; P2.2, P2.3 ← Input mode

LD      P3CONL,#05H  ; P3.0, P3.1 ← ADC input mode
•
•
•

```

 **PROGRAMMING TIP — Clearing Port 0 Interrupt Pending Bits**

This sample program shows you how to clear the interrupt pending bits for port 1. The program parameters are as follows:

- Enable only the interrupt level 1 (IRQ1) for P1.0–P1.1
- Set the interrupt priorities as P1.0 > P1.1

```

                ORG      0C0H
                VECTOR   EXT_INT_P10
                VECTOR   EXT_INT_P11
                .
                .
                .
nRESET         ORG      0100H
                DI              ; Disable all interrupts
                SB0             ; Select bank 0
                LD      BTCON,#0AAH ; Disable the watchdog timer
                LD      CLKCON,#98H ; Non-divided clock
                CLR     SPL      ; Stack pointer low byte ← "0"
                                ; Stack area starts at 0FFH
                .
                .
                .
                LD      IMR,#06H ; Enable IRQ1 and IRQ2 interrupts
                LD      IPR,#11H ; IRQ1 > IRQ2
                LD      P1CONL,#0AH ; P1.0, P1.1 ← Input mode; falling edge interrupts
                .
                .
                .
                SRP     #0C0H    ; Set register pointer to 0C0H
                EI              ; Enable interrupts
                .
                .
                .
MAIN           NOP
                NOP
                .
                .
                .
                JP      T,MAIN
                .
                .
                .

```

(Continued on next page)

 **PROGRAMMING TIP — Clearing Port 1 Interrupt Pending Bits (Continued)**

```

EXT_INT_P10:                                ; P1.0 external interrupt service
      PUSH      PP                            ; Save page pointer to stack
      PUSH      RP0                          ; Save register pointer 0 to stack
      PUSH      RP1                          ; Save register pointer 1 to stack
      .
      .
      .
      POP       RP1                          ; Restore register pointer 1 value
      POP       RP0                          ; Restore register pointer 0 value
      POP       PP                            ; Restore page pointer value
      IRET                                     ; Return from interrupt service routine

EXT_INT_P11:                                ; P1.1 external interrupt service
      PUSH      PP
      PUSH      RP0
      PUSH      RP1
      .
      .
      .
      POP       RP1
      POP       RP0
      POP       PP
      IRET

```

NOTES

10 BASIC TIMER and TIMER 0

MODULE OVERVIEW

The S3C880A/F880A microcontrollers have two default timers: an 8-bit *basic timer (BT)* and an 8-bit general-purpose timer/counter, called *timer 0 (T0)*.

The basic timer (BT) has two alternative functions: 1) it can be used as a watchdog timer that provides an automatic reset mechanism in the event of a system malfunction, and 2) it can be used to signal the end of the required oscillation stabilization interval after a reset or a Stop mode release. The components of the basic timer are:

- Clock frequency divider (f_{OSC} divided by 4096, 1024, or 128) with multiplexer
- 8-bit basic counter, BTCNT (set 1, bank 0, FDH, read-only)
- Basic timer control register, BTCON (set 1, D3H, read/write)
- Clock frequency divider (f_{OSC} divided by 4096, 256, or 8) with multiplexer
- 8-bit counter (T0CNT), 8-bit comparator, and 8-bit reference data register (T0DATA)
- Timer 0 match interrupt (T0INT) generation
- Timer 0 control register, T0CON (set 1, D2H, read/write)

BASIC TIMER CONTROL REGISTER (BTCON)

The basic timer control register, BTCON, is used to select the input clock frequency, clear the basic timer counter and frequency dividers, and enable or disable the watchdog timer function. It is located in set 1, address D3H, and is read/write addressable using Register addressing mode only.

A reset clears BTCON to '00H'. This enables the watchdog function and selects a basic timer clock frequency of $f_{OSC}/4096$. To disable the watchdog function, you must write the signature code '1010B' to the basic timer register control bits BTCON.7–BTCON.4.

The 8-bit basic timer counter, BTCNT (set 1, bank 0, FDH), can be cleared during the normal operation by writing a "1" to BTCON.1. To clear the frequency dividers for both the basic timer input clock and the timer 0 clock, you should write a "1" to BTCON.0.

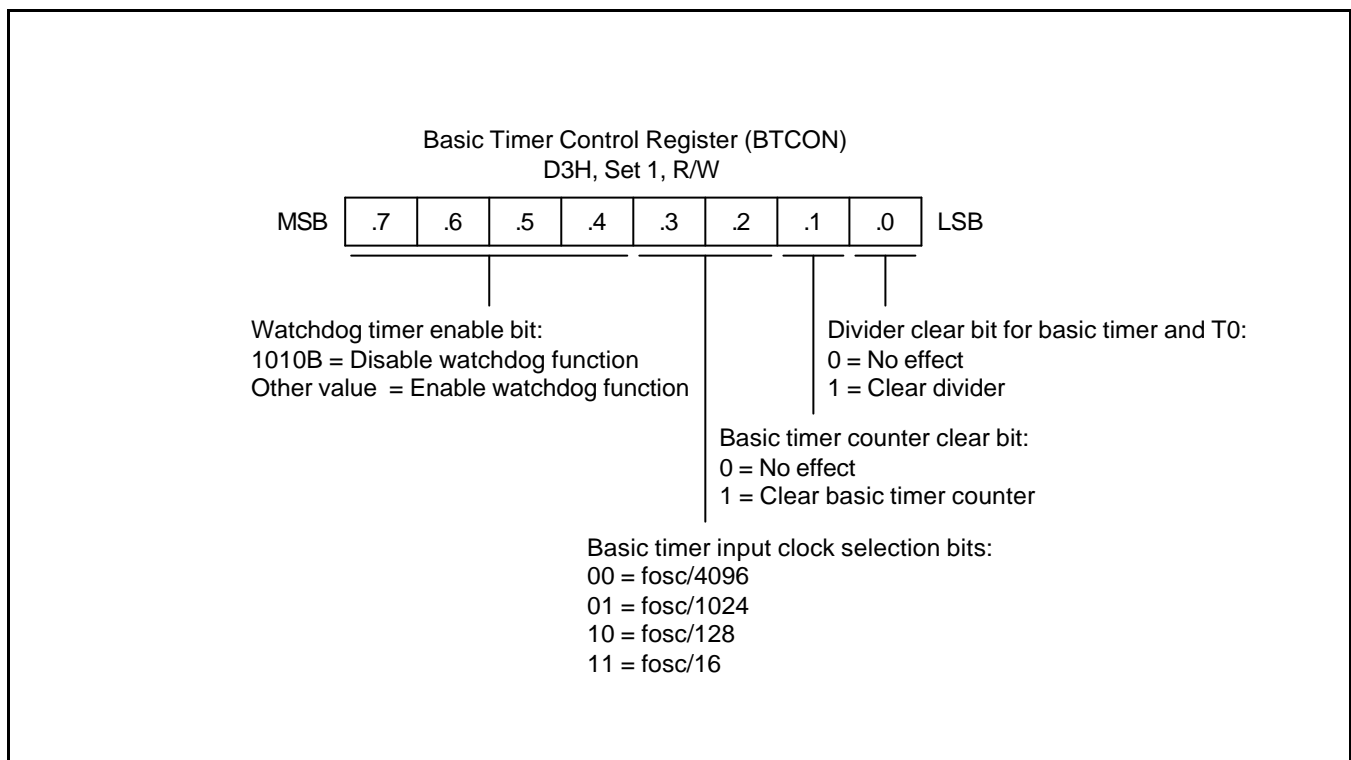


Figure 10-1. Basic Timer Control Register (BTCON)

BASIC TIMER FUNCTION DESCRIPTION

Watchdog Timer Function

The basic timer overflow signal can be programmed to generate a reset by setting the BTCON.7–BTCON.4 bits to any value other than '1010B'. (The '1010B' value disables the watchdog function.) A reset clears the BTCON register to '00H', automatically enabling the watchdog timer function. A reset also selects the CPU clock (as determined by the CLKCON register setting) divided by 4096 as the BT clock.

With every overflow of the basic timer counter, a reset occurs. During the normal operation, this overflow-generated reset should be prevented from occurring. To do this, the basic timer counter value must be cleared by software (write BTCON.1 to "1") in regular intervals.

If a system malfunction occurs due to circuit noise or some other error condition, the basic timer counter clear operation may not be executed and a basic timer overflow will occur, initiating a system reset. In other words, in normal operating condition the basic timer overflow loop (a bit 7 overflow of the 8-bit BT counter) is always broken by a clear counter instruction.

An application program can use the basic timer as a watchdog timer to trigger an automatic system reset in case a malfunction occurs.

Oscillation Stabilization Interval Timer Function

The basic timer determines the oscillation stabilization interval after a reset or the release of Stop mode by an external interrupt. Whenever a reset or an external interrupt occurs during Stop mode, the oscillator begins operating. The basic timer value then starts increasing at the rate of $f_{OSC}/4096$ (in the case of a reset), or at the rate of the preset clock source (in the case of an external interrupt).

When bit 4 of the BT counter is set to "1", a signal is generated to indicate that the stabilization interval has elapsed. This allows the clock signal to be gated on to the CPU so that it can resume normal operation. In summary, the following events occur when Stop mode is released:

1. During Stop mode a power-on reset or an external interrupt occurs to trigger a Stop mode release, and oscillation starts.
2. If a power-on reset occurs, the basic timer counter increases at the rate of $f_{OSC}/4096$. If an external interrupt is used to release Stop mode, the basic timer value increases at the rate of the preset clock source.
3. Clock oscillation stabilization interval begins and continues until bit 3 of the basic timer counter overflows.
4. When bit 4 of BTCNT is set to "1", the normal CPU operation resumes.

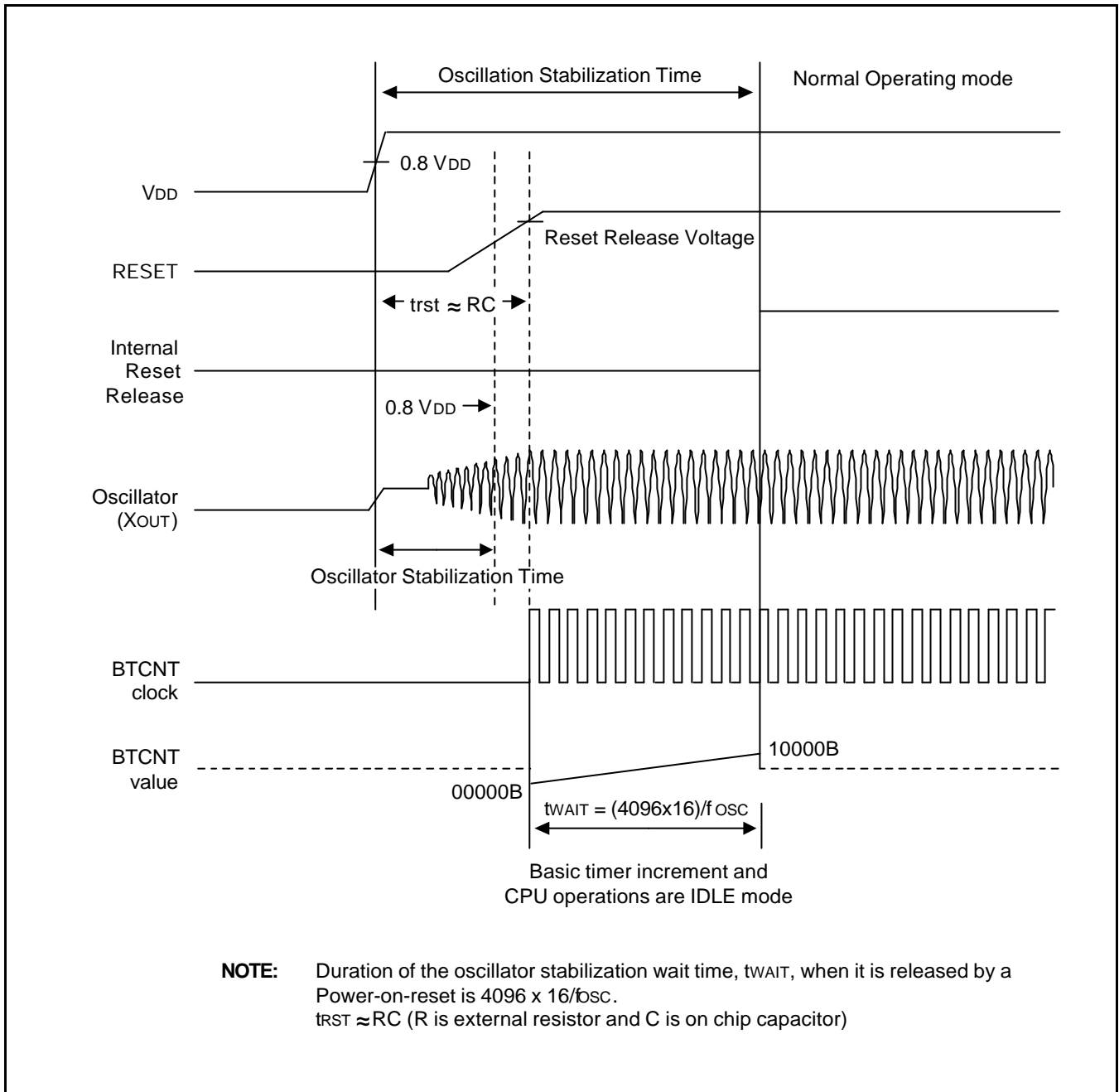


Figure 10-2. Oscillation Stabilization Time on nRESET

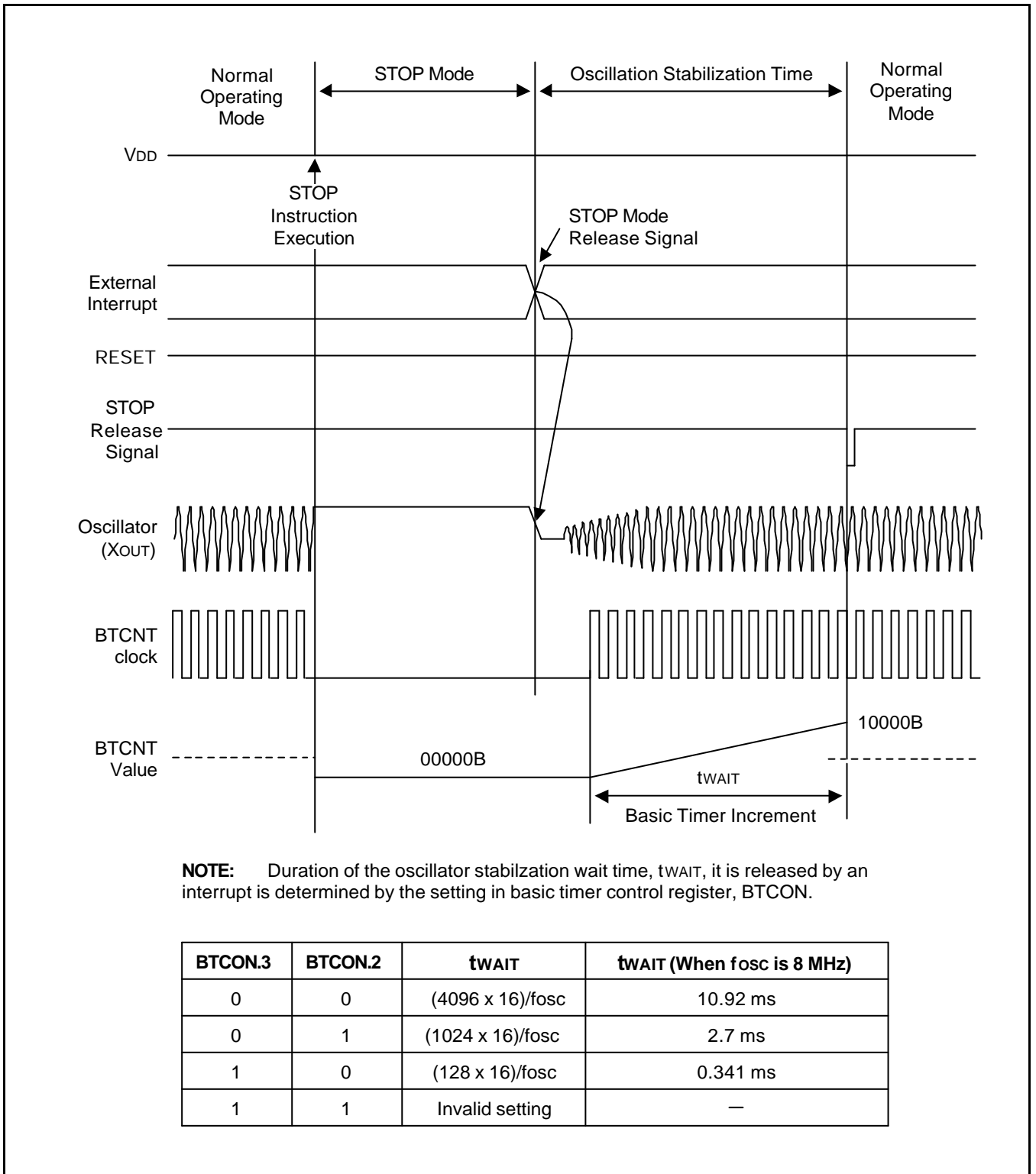


Figure 10-3. Oscillation Stabilization Time on STOP Mode Release

TIMER 0 CONTROL REGISTER (T0CON)

The timer 0 control register, T0CON, is used to select the timer 0 operating mode (interval timer) and input clock frequency, clear the timer 0 counter, and enable the T0 match interrupt. It also contains a pending bit for T0 match interrupt. It is located in set 1, address D2H, and is read/write addressable using register addressing mode.

A reset clears T0CON to '00H'. This sets timer 0 to normal interval timer mode, selects an input clock frequency of $f_{OSC}/4096$, and disables the T0 match interrupt. The T0 counter can be cleared at any time during the normal operation by writing a "1" to T0CON.3.

To enable the T0 match interrupt (T0INT, IRQ0, vector FCH), you must set T0CON.1 to "1". The interrupt service routine must clear the pending condition by writing a "0" to the T0 interrupt pending bit, T0CON.0.

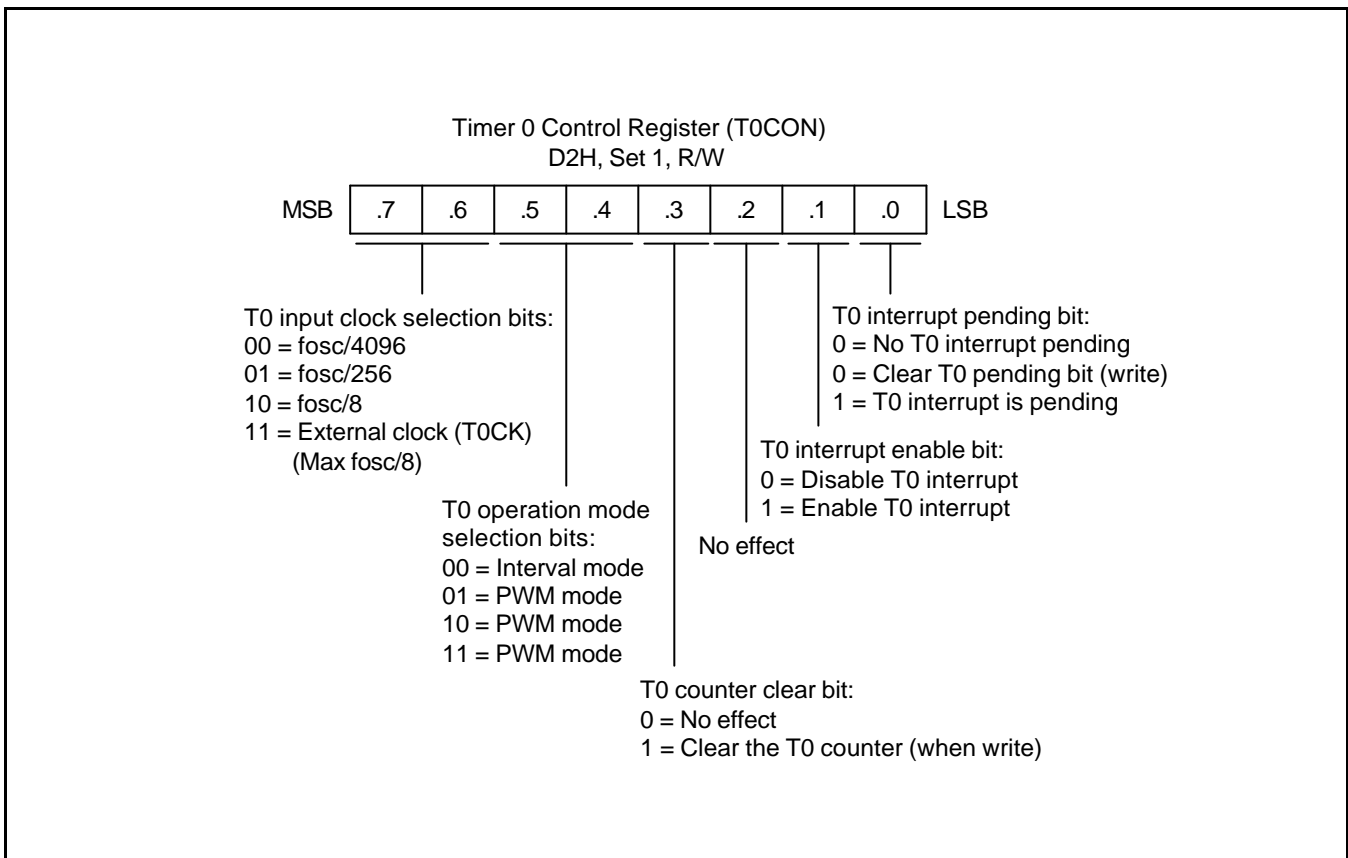


Figure 10-4. Timer 0 Control Register (T0CON)

TIMER 0 FUNCTION DESCRIPTION

T0 Interrupts (IRQ0, Vector FCH)

The T0 module can generate one interrupt: the timer 0 match interrupt (T0INT). T0INT is also in the level IRQ0, vector address: FCH. The T0INT pending condition must be cleared by software by writing a "0" to the T0CON.0 pending bit.

Interval Timer Mode

In interval timer mode, a match signal is generated when the counter value is identical to the value written to the T0 reference data register, TODATA. The match signal generates a T0 match interrupt (T0INT, vector FCH) and then clears the counter. If, for example, you write the value '10H' to TODATA, the counter will increment until it reaches '10H'. At this point, the T0 interrupt request is generated, the counter value is reset and counting resumes.

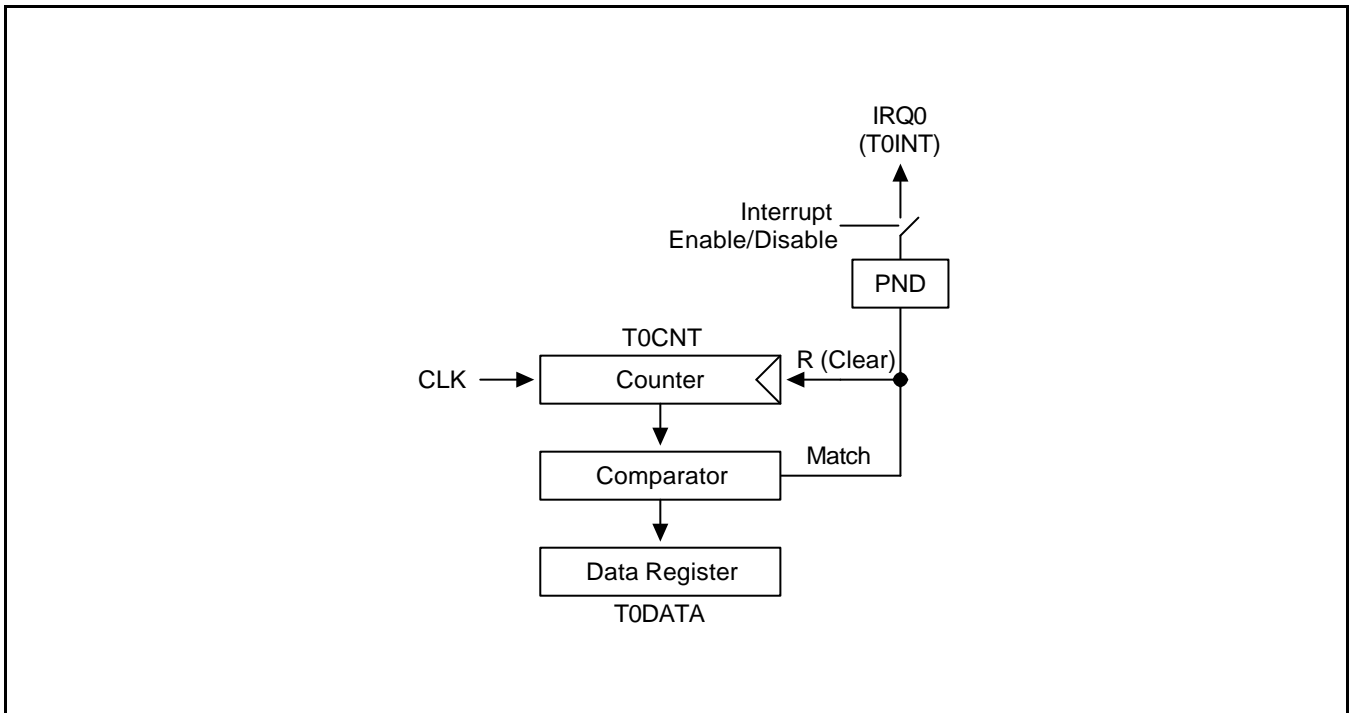


Figure 10-5. Timer 0 Function Diagram (Interval Timer Mode)

Pulse Width Modulation Mode

Pulse width modulation (PWM) mode lets you program the width (duration) of the pulse that is output at the T0 pin. As in interval timer mode, a match signal is generated when the counter value is identical to the value written to the T0 data register. In PWM mode, however, the match signal does not clear the counter (it runs continuously, overflowing at 'FFH', and continuing incrementing from '00H').

Although it is possible to use the match signal to generate a T0INT interrupt, an interrupt is typically not used in PWM-type applications. Instead, the pulse at the T0 pin is held to Low level as long as the reference data value is less than or equal to the counter value; the pulse is then held to high level for as long as the data value is greater than the counter value. One pulse width is equal to $t_{CLK} \times 256$. (See figure 10-6)

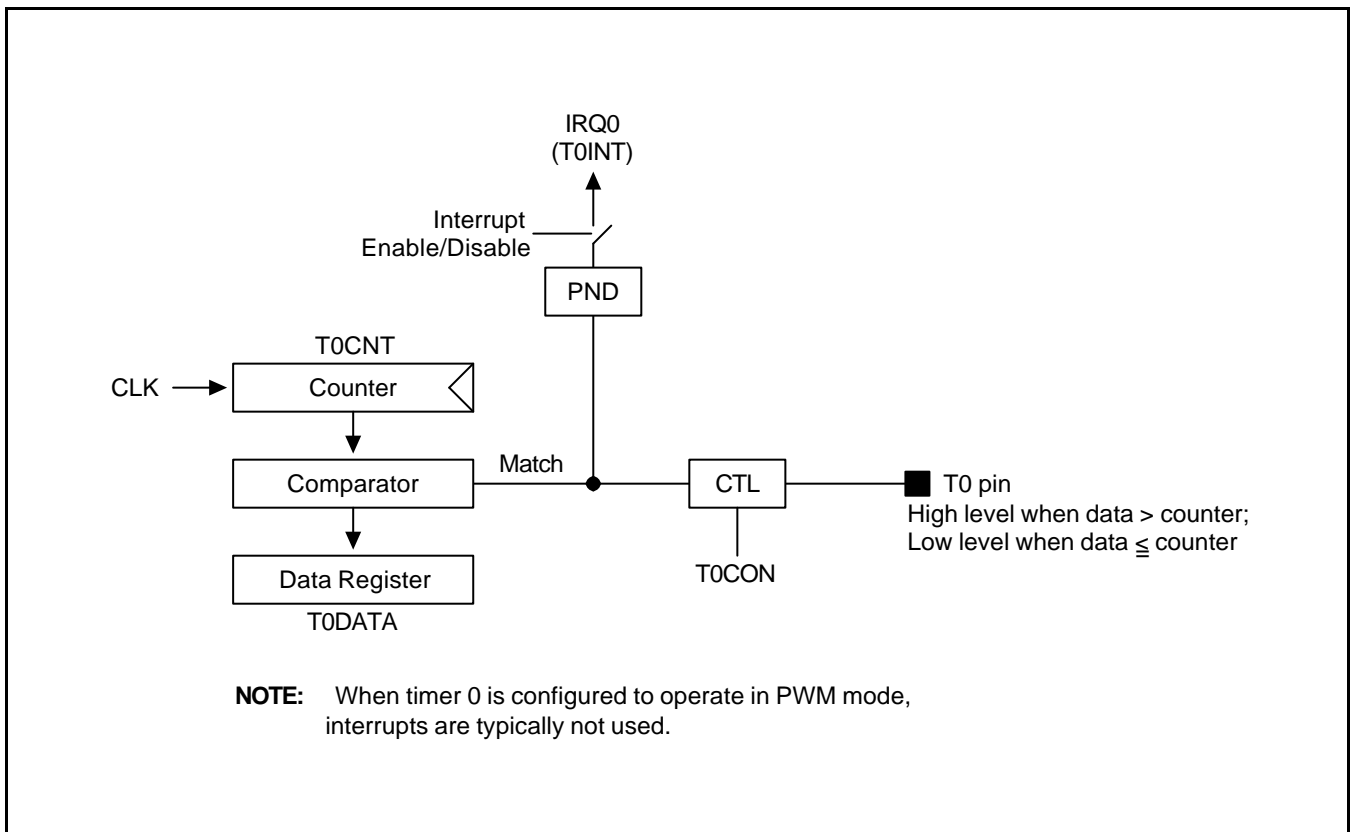


Figure 10-6. Timer 0 Function Diagram (PWM Mode)

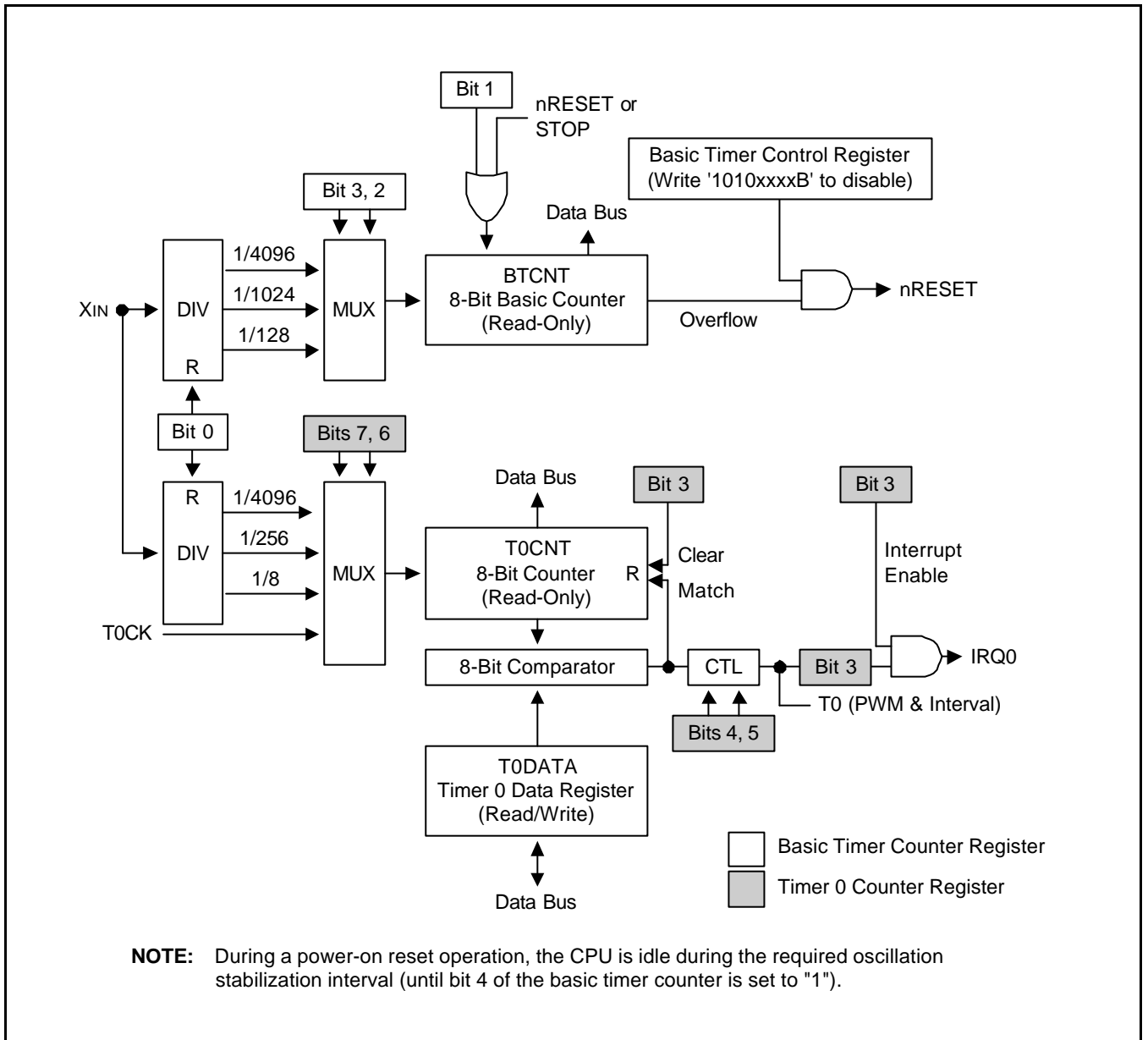



Figure 10-7. Basic Timer and Timer 0 Block Diagram

 **PROGRAMMING TIP — Configuring the Basic Timer**

This example shows how to configure the basic timer to sample specifications:

```

                ORG        0100H

nRESET        DI                ; Disable all interrupts
              SB0              ; Select bank 0
              LD        BTCON,#0AAH ; Disable the watchdog timer
              LD        CLKCON,#98H ; Non-divided clock
              CLR        SYM      ; Disable global and fast interrupts
              CLR        SPL      ; Stack pointer low byte ← "0"
              ; Stack area starts at 0FFH
              .
              .
              .
              SRP        #0C0H    ; Set register pointer ← 0C0H
              EI                ; Enable interrupts
              .
              .
              .
MAIN          LD        BTCON,#52H ; Enable the watchdog timer
              ; Basic timer clock: fOSC/4096
              ; Clear basic timer counter

              NOP
              NOP
              .
              .
              .
              JP        T,MAIN
              .
              .
              .

```

PROGRAMMING TIP — Configuring Timer 0

This sample program sets timer 0 to interval timer mode, determining the frequency of the oscillator clock, and the execution sequence which follows a timer 0 interrupt. The program given are as follows:

- Timer 0 is used in interval mode; the timer interval is set to 4 milliseconds
- Oscillation frequency is 6 MHz
- General register 60H (page 0) ← 60H + 61H + 62H + 63H + 64H (page 0) is executed after a timer 0 interrupt

```

ORG      0FCH                ; Timer 0 interrupt (match)
VECTOR   T0INT
ORG      0100H

nRESET   DI                  ; Disable all interrupts
          SB0                 ; Select bank 0
          LD      BTCON,#0AAH ; Disable the watchdog timer
          LD      CLKCON,#98H ; Non-divided clock
          CLR     SYM          ; Disable global and fast interrupts
          CLR     SPL          ; Stack pointer low byte ← "0"
          ; Stack area starts at 0FFH
          .
          .
          LD      T0CON,#42H  ; 01000010B
          ; Input clock is fOSC/256
          ; Interval timer mode
          ; Enable the timer 0 interrupt
          LD      T0DATA,#5DH ; Set timer interval to 4 milliseconds
          ; (6 MHz/256) ÷ (93 + 1) = 0.25 kHz (4 ms)
          SRP     #0C0H       ; Set register pointer ← 0C0H
          EI      ; Enable interrupts
          .
          .

T0INT    PUSH     PP          ; Save page pointer to the stack
          PUSH     RP0        ; Save RP0 to stack
          SB0                 ; Select bank 0
          LD      PP,#00H     ; Page pointer ← 00H (select page 0)
          SRP0    #60H        ; RP0 ← 60H
          INC     R0           ; R0 ← R0 + 1
          ADD     R2,R0        ; R2 ← R2 + R0
          ADC     R3,R2        ; R3 ← R3 + R2 + Carry
          ADC     R4,R0        ; R4 ← R4 + R0 + Carry
          CP      R0,#32H     ; 50 × 4 = 200 ms
          JR      ult,NO_200MS_SET
          BITS    R1.2        ; Bit setting (61.2H)

NO_200MS_SET:
          LD      T0CON,#42H  ; Clear pending bit
          POP     RP0         ; Restore register pointer 0 value
          POP     PP          ; Restore page pointer value
          IRET    ; Return from interrupt service routine

```

NOTES

11

TIMER A

OVERVIEW

The S3C880A/F880A microcontrollers have an 8-bit timer/counter (timer A). Each timer has a control register, an 8-bit counter register, an 8-bit data register, an 8-bit comparator. Timer A runs continuously. Counter register addresses are not mapped and they cannot, therefore, be read or written.

TIMER CLOCK INPUT

Timer A has different clock input options. You can select the non-divided CPU clock or the CPU clock divided by 1000. The selected clock input frequency for each timer can be scaled using the 4-bit prescaler that is located in bits 4–7 of the TACON register.

TIMER A INTERRUPT CONTROL

Timer A generate a match signal when the count value is equal to the referenced data value in the TADATA. When the interrupt enable bit is set for timer A, an interrupt is generated whenever a match is detected. The corresponding count register is then cleared and counting resumes. To enable the timer A interrupt, you should set TACON.2 to "1".

The timer A interrupt pending bit is TACON.1. When a timer A pending bit read operation shows a "0" value, no interrupt is pending; when it is "1", an interrupt request is pending. When the request is acknowledged by the CPU and the service routine starts, the pending bit must be cleared by the interrupt service routine. To do this, you must write a "0" to the appropriate bit location.

TIMER A FUNCTION DESCRIPTION

When a match occurs, the timer is reset to zero.

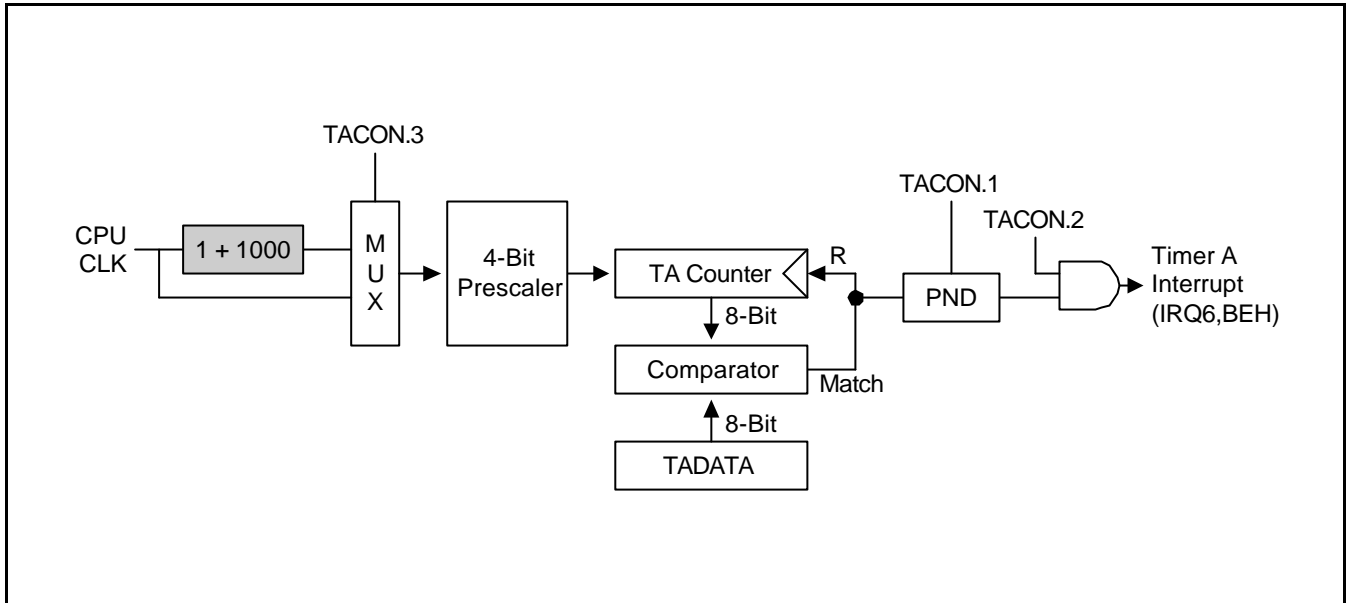


Figure 11-1. Timer A Block Diagram

TIMER A CONTROL REGISTER (TACON)

The timer A control register, TACON, is located at F2H in set 1, bank 0. All bits are read/write addressable. The TACON register settings control four functions:

- Interrupt enable/disable
- Interrupt pending control (read for status, write to clear)
- Clock source selection
- Prescaler (4-bit) for timer clock input

TACON.1 is the pending flag for the timer A interrupt (IRQ6, vector BEH). Application software can poll the TAIP bit to detect timer A interrupt requests. When an interrupt request is acknowledged, the interrupt service routine must clear TACON.1 by writing a "0" to the bit location.

Note that there are two clock source selections for timer A: the CPU clock divided by 1000 or the non-divided CPU clock.

A reset clears TACON to '00H', selecting the CPU clock/1000, and disabling the timer A interrupt.

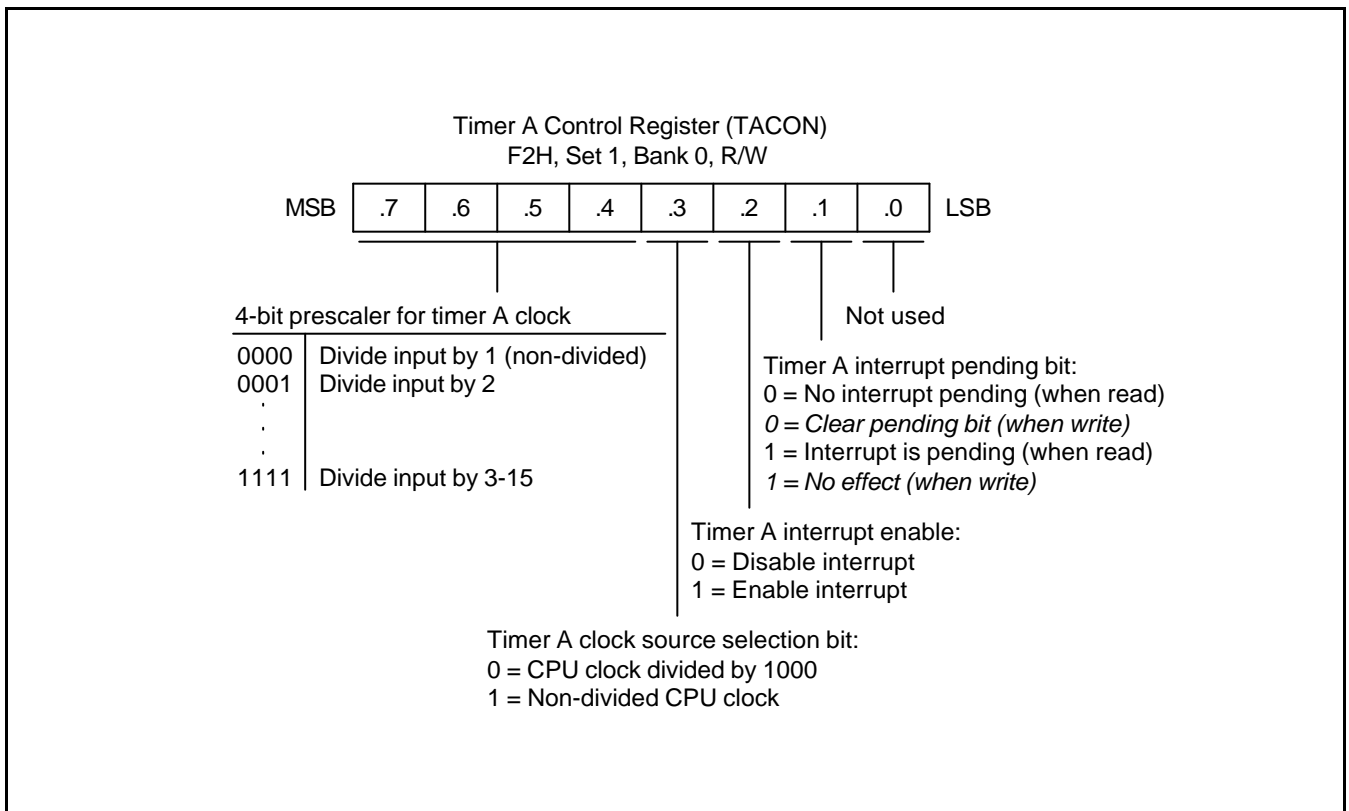


Figure 11-2. Timer A Control Register (TACON)

 **PROGRAMMING TIP — Configuring Timer A**

This example sets timer A to normal interval mode, determining the oscillation frequency of the timer clock, the execution sequence that follows a timer A interrupt. The program parameters are:

- The timer interval is set to 10 milliseconds
- Oscillation frequency = 6 MHz
- General register 70H (page 0) ← 70H + 71H + 72H + 73H + 74H (page 0) is executed after a timer A interrupt

```

                ORG      0BEH          ; Timer A interrupt
                VECTOR   TAINT
nRESET          ORG      0100H
                DI              ; Disable all interrupts
                SB0          ; Select bank 0
                LD      BTCON,#0AAH   ; Disable the watchdog timer
                LD      CLKCON,#98H   ; Non-divided clock
                CLR     SYM          ; Disable global and fast interrupts
                CLR     SPL          ; Stack pointer low byte ← "0"
                ; Stack area starts at 0FFH
                .
                .
                .
                LD      TACON,#54H    ; 01010100B
                ; PS ← 5 (divide-by-6)
                ; CPU clock/1000
                ; Select interval mode for timer A
                LD      TADATA,#59H   ; 10-ms interval time
                ; (6 MHz/1000) ÷ (59 + 1) = 100 Hz (10 ms)
                SRP     #0C0H        ; Set register pointer ← 0C0H
                EI              ; Enable interrupts
                .
                .
                .
TAINT           PUSH    PP           ; Save page pointer to stack
                PUSH    RP0         ; Save register pointer 0 to stack
                SB0          ; Select bank 0
                LD      PP,#00H      ; Page pointer ← 00H (select page 0)
                SRP0     #70H        ; RP0 ← 70H
                INC     R0           ; R0 ← R0 + 1
                ADD     R2,R0        ; R2 ← R2 + R0
                ADC     R3,R2        ; R3 ← R3 + R2 + Carry
                ADC     R4,R0        ; R4 ← R4 + R0 + Carry
                CP      R0,#64H      ; 100 × 10 ms = 1000 ms (1 second)
                JR      ult,NO_1SEC_SET
                BITS     R1.2        ; Bit setting (71.2H)
    
```

(Continued on next page)

 **PROGRAMMING TIP — Configuring Timer A (Continued)**

NO_1SEC_SET:

LD	TACON,#54H	; Clear pending bit
POP	RP0	; Restore register pointer 0 value
POP	PP	; Restore page pointer value
IRET		; Return from interrupt service routine

NOTES

12 PWM AND CAPTURE

PWM/CAPTURE MODULE

The S3C880A/F880A microcontrollers have two 14-bit PWM circuits and four 8-bit PWM circuits. The 14-bit circuits are called PWM0 and PWM1; the 8-bit circuits are PWM2–PWM5. The operation of all the PWM circuits is controlled by a single control register, PWMCON. PWMCON also contains a 3-bit prescaler for adjusting the PWM frequency (cycle).

The capture function, called capture A, is integrated in this block. Using PWMCON settings, you can enable the capture A interrupt and select the desired triggering edge for data capture on the CAPA input pin.

The PWM counter is a 14-bit incrementing counter. It is used by the 14-bit PWM circuits. To start the counter and enable the PWM circuits, you must set PWMCON.5 to "1". If the counter is stopped, it retains its current count value; when re-started, it resumes counting from the retained count value.

A 3-bit prescaler controls the clock input frequency to the PWM counter. By modifying the prescaler value, you can divide the input clock by one (non-divided), two, three, four, five, six, seven, or eight. The prescaler output is the clock frequency of the PWM counter.

PWM CONTROL REGISTER (PWMCON)

The control register for the PWM module, PWMCON, is located at the register address F8H in set 1, bank 0. Bit settings in the PWMCON register control the following functions:

- 3-bit prescaler for scaling the PWM counter clock
- Stop/start (or resume) the PWM counter operation
- Capture A interrupt enable and capture A edge selection

A reset clears all PWMCON bits to logic zero, disabling the entire PWM module.

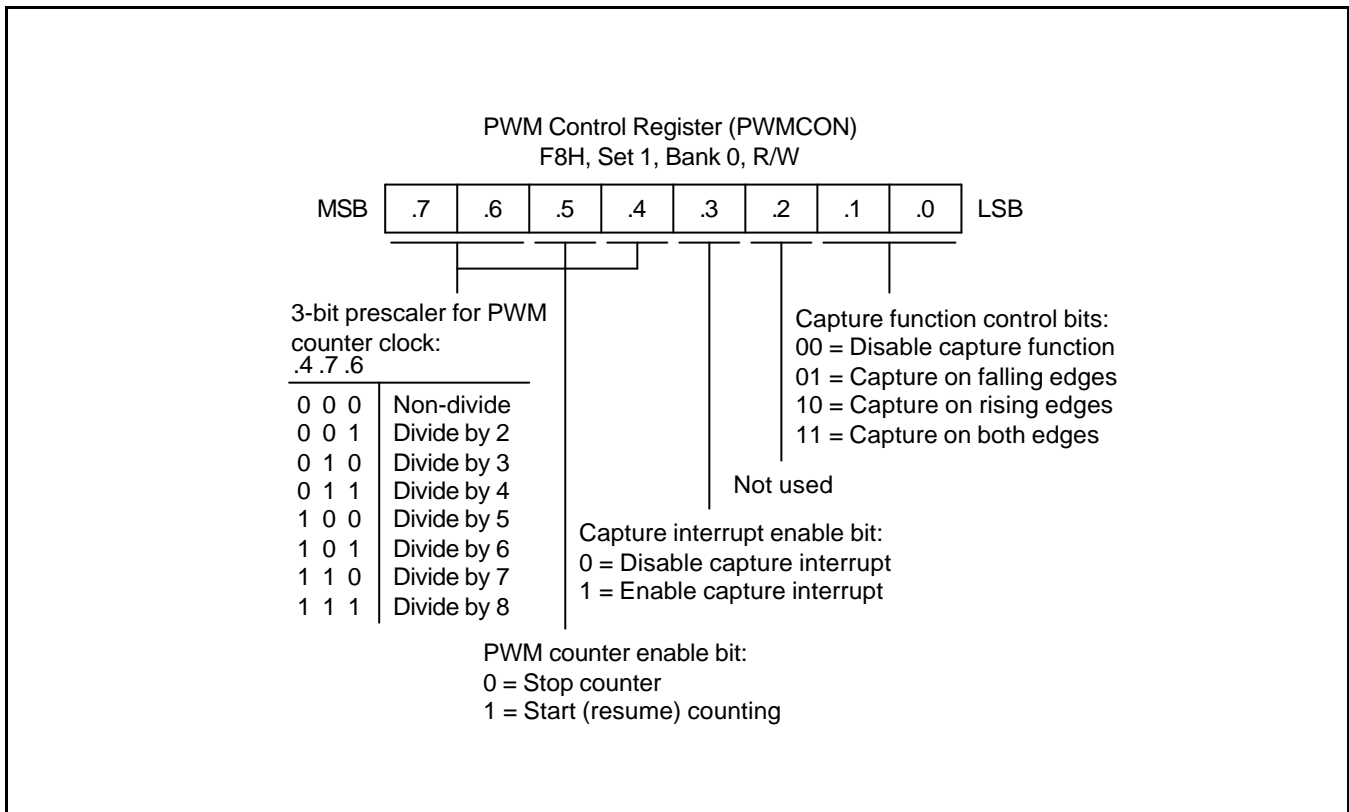


Figure 12-1. PWM Control Register (PWMCON)

PWM2–PWM5

The S3C880A/F880A microcontrollers have four 8-bit PWM circuits, called PWM2–PWM5. These 8-bit circuits have the following components:

- 14-bit counter with 3-bit prescaler
- 8-bit comparators
- 8-bit PWM data registers (PWM2–PWM5)
- PWM output pins (PWM2–PWM5)

The PWM2–PWM5 circuits are controlled by the PWMCON register (F8H, set 1, bank 0).

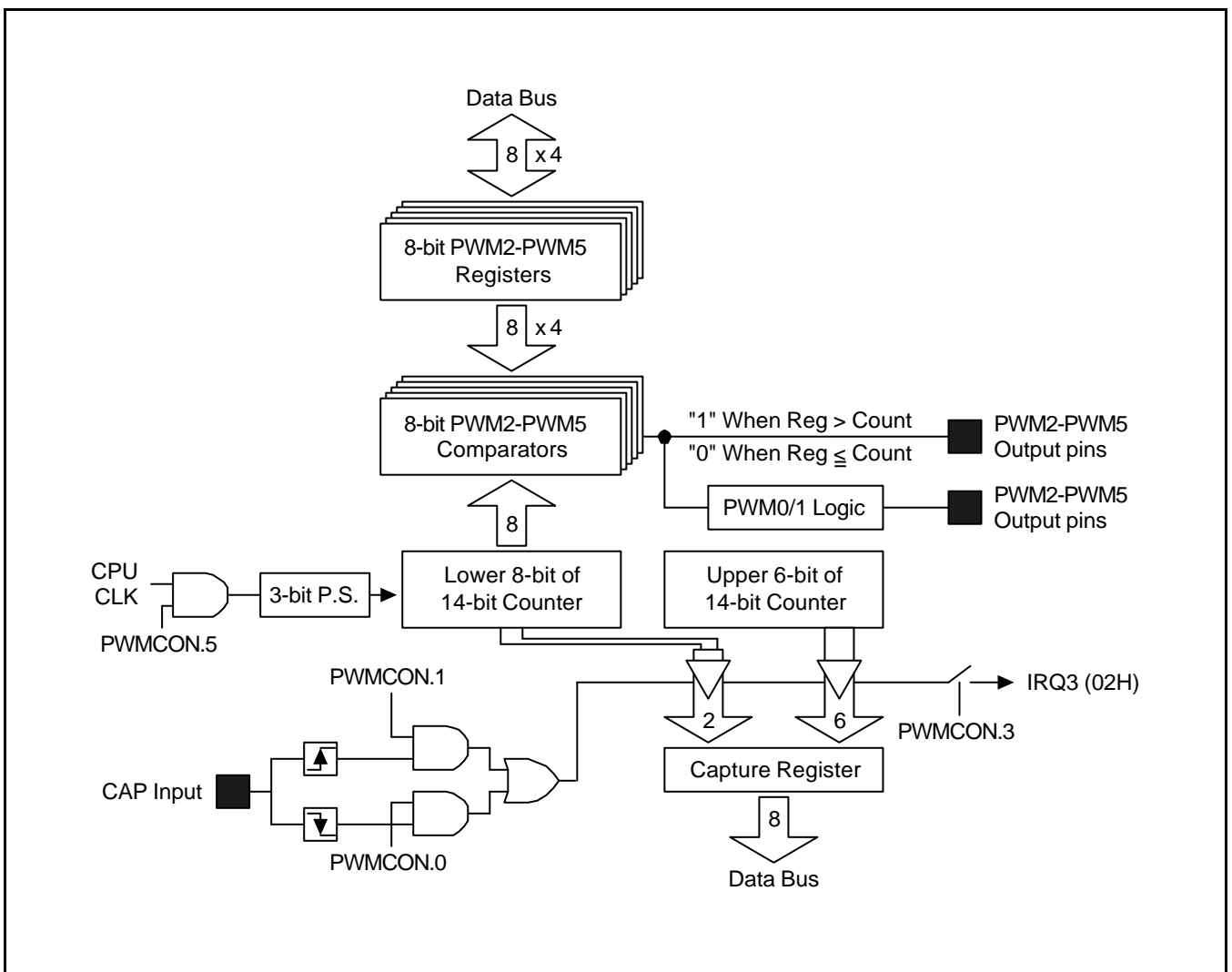


Figure 12-2. Block Diagram for PWM2–PWM5

PWM2–PWM5 FUNCTION DESCRIPTION

All the four 8-bit PWM circuits function identically: each has its own 8-bit data register and 8-bit comparator. Each circuit compares a unique data register value to the lower 8-bit value of the 14-bit PWM counter.

The PWM2–PWM5 data registers are located in set 1, bank 1, at locations F8H–FBH, respectively. These data registers are read/write addressable. By loading specific values into the respective data registers, you can modulate the pulse width at the corresponding PWM output pins, PWM2–PWM5.

The level at the output pins toggles High and Low at a frequency equal to the counter clock, divided by 256 (2^8). The duty cycle of the PWM0 and PWM1 pins ranges from 0% to 99.6%, based on the corresponding data register values.

To determine the PWM output duty cycle, its 8-bit comparator sends the output level High when the data register value is greater than the lower 8-bit count value. The output level is Low when the data register value is less than or equal to the lower 8-bit count value. The output level at the PWM2–PWM5 pins remains at Low level for the first 256 counter clocks. Then, each PWM waveform is repeated continuously, at the same frequency and duty cycle, until one of the following three events occurs:

- The counter is stopped
- The counter clock frequency is changed
- A new value is written to the PWM data register

STAGGERED PWM OUTPUTS

The PWM2–PWM5 outputs are staggered in order to reduce the overall noise level on the pulse width modulation circuits. If you load the same value to the PWM2–PWM5 data registers, a match condition (data register value is equal to the lower 8-bit count value) will occur on the same clock cycle for all the four 8-bit PWM circuits. The output of PWM3, PWM4, and PWM5 are delayed by one-half of a counter clock for subsequent clock cycles (see Figure 12-4).

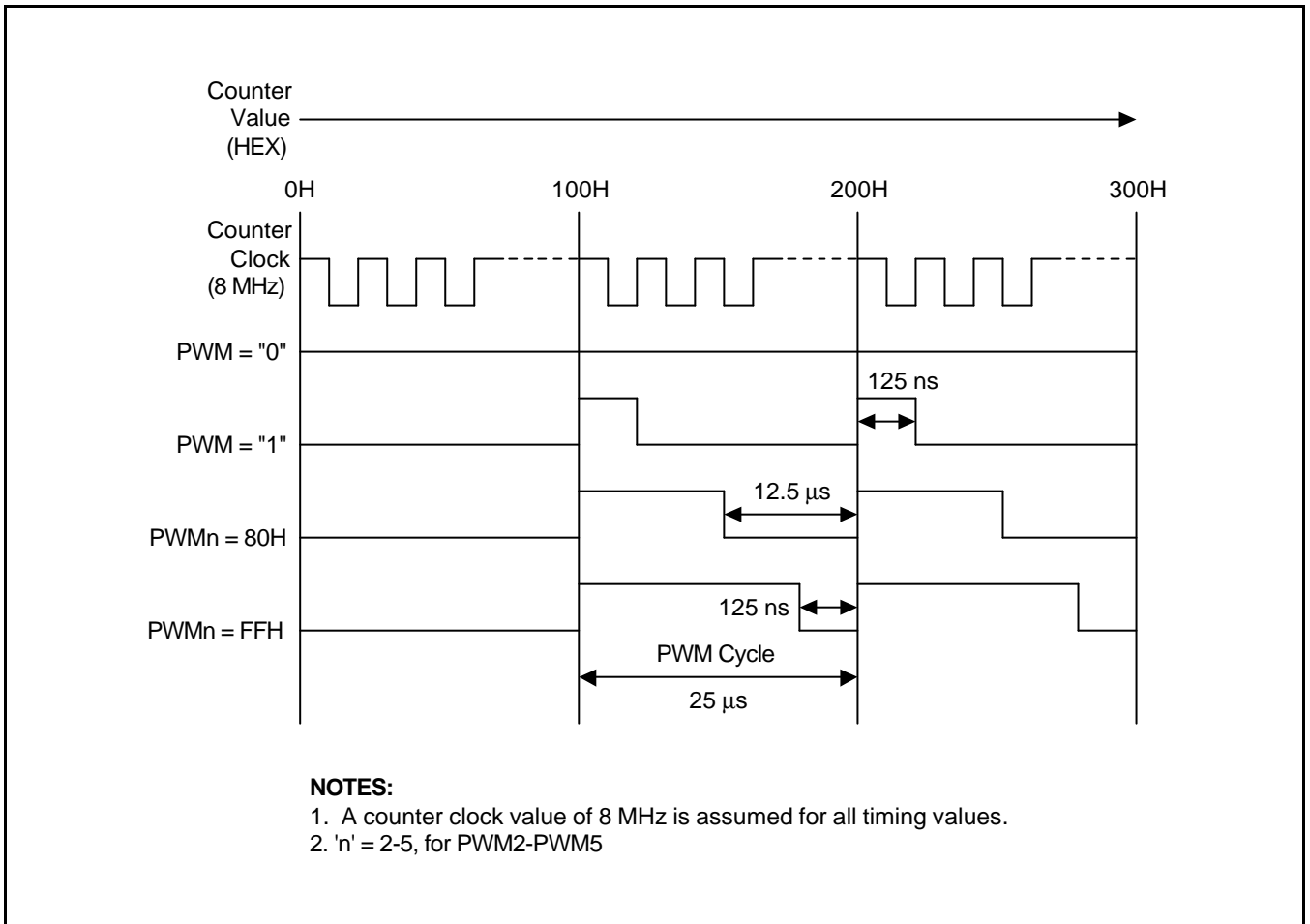


Figure 12-3. PWM Waveforms for PWM2–PWM5

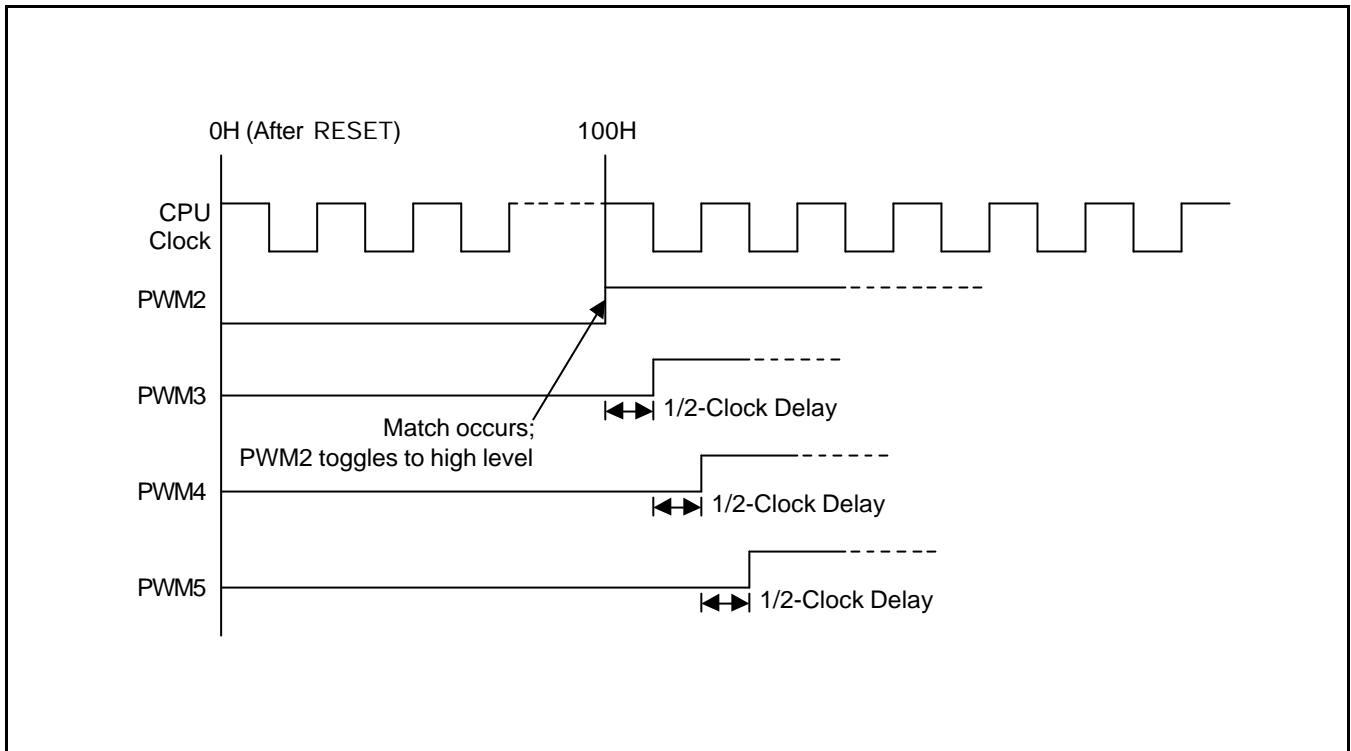


Figure 12-4. PWM Clock to PWM2–PWM5 Output Delays

PWM0–PWM1

The S3C880A/F880A pulse width modulation (PWM) module has two 14-bit PWM circuits (PWM0 and PWM1). The 14-bit PWM circuits have the following components:

- 14-bit counter with 3-bit prescaler (an 8-bit counter with 6-bit extension is used for 14-bit output resolution)
- 8-bit comparator and extension cycle circuit
- 8-bit reference data registers (PWM0, PWM1)
- 6-bit extension data registers (PWM0EX, PWM1EX)
- PWM output pins (PWM0, PWM1)

The PWM0 and PWM1 circuits are enabled by the PWMCON register (F8H, set 1, bank 0).

PWM COUNTER

The PWM counter is a 14-bit increasing counter comprised of a lower byte counter and an upper byte counter.

To determine the PWM module's base operating frequency, the lower byte counter is compared to the PWM data register value. In order to achieve higher resolutions, the lower six bits of the upper byte counter can be used to modulate the "stretch" cycle. To control the "stretching" of the PWM output duty cycle at specific intervals, the 6-bit extended counter value is compared with the 6-bit value (bits 2–7) that you write to the module's extension register.

PWM DATA AND EXTENSION REGISTERS

Two PWM (duty) data registers, located in set 1, bank 0, determine the output value generated by each 14-bit PWM circuit. PWM0 and PWM1 are read/write addressable.

- 8-bit data registers PWM0 (F4H) and PWM1(F6H)
- 6-bit extension registers PWM0EX (F5H) and PWM1EX (F7H) of which only bits 2–7 are used

To program the required PWM output, you should load the appropriate initialization values into the 8-bit data registers (PWM0, PWM1) and the 6-bit extension registers (PWM0EX, PWM1EX). To start the PWM counter, or to resume counting, you should set PWMCON.5 to "1".

A reset operation disables all PWM output. The current counter value is retained when the counter stops. When the counter starts, counting resumes at the retained value.

PWM CLOCK RATE

The timing characteristics of both 14-bit output channels are identical, and are based on the maximum 8-MHz CPU clock frequency. The 2-bit prescaler value in the PWMCON register determines the frequency of the counter clock. You can set PWMCON.6 and PWMCON.7 to divide the CPU clock frequency by 1 (non-divided), 2, 3, 4, 5, 6, 7, or 8.

Because the maximum CPU clock rate for the S3C880A/F880A microcontrollers is 8 MHz, the maximum base PWM frequency is 31.25 kHz (8 MHz divided by 256). This assumes a non-divided CPU clock.

Table 12-1. PWM0 and PWM1 Control and Data Registers

Register Name	Mnemonic	Address (Set 1, Bank 0)	Function
PWM0 data registers	PWM0	F4H	8-bit PWM0 basic cycle frame value
	PWM0EX	F5H	6-bit extension ("stretch") value
PWM1 data registers	PWM1	F6H	8-bit PWM1 basic cycle frame value
	PWM1EX	F7H	6-bit extension ("stretch") value
PWM control register	PWMCON	F8H	PWM0 counter stop/start (resume), and 3-bit prescaler for CPU clock; also contains capture A control settings

PWM0 AND PWM1 FUNCTION DESCRIPTION

The PWM output signal toggles to Low level whenever the lower 8-bit counter matches the reference value stored in the module's data register (PWM0, PWM1). If the value in the PWM data register is not zero, an overflow of the lower counter causes the PWM output to toggle to High level. In this way, the reference value written to the data register determines the module's base duty cycle.

The value in the 6-bit extension counter (the lower six bits of the upper counter) is compared with the extension settings in the 6-bit extension data register (PWM0EX, PWM1EX). This 6-bit extension counter value (bits 2–7), together with extension logic and the PWM module's extension register, is then used to "stretch" the duty cycle of the PWM output. The "stretch" value is one extra clock period at specific intervals, or cycles (see Table 12-2).

If, for example, the value in the extension register is '1', the 32nd cycle will be one pulse longer than the other 63 cycles. If the base duty cycle is 50%, the duty of the 32nd cycle will therefore be "stretched" to approximately 51% duty. For example, if you write 80H to the extension register, all odd-numbered pulses will be one cycle longer. If you write FCH to the extension register, all pulses will be stretched by one cycle except the 64th pulse. PWM output goes to an output buffer and then to the corresponding PWM0 and PWM1 output pin. In this way, you can obtain high output resolution at high frequencies.

Table 12-2. PWM Output "Stretch" Values for Extension Registers PWM0EX and PWM1EX

PWM0EX/PWM1EX Bit	"Stretched" Cycle Number
7	1, 3, 5, 7, 9, ..., 55, 57, 59, 61, 63
6	2, 6, 10, 14, ..., 50, 54, 58, 62
5	4, 12, 20, ..., 44, 52, 60
4	8, 24, 40, 56
3	16, 48
2	32
1	Not used
0	Not used

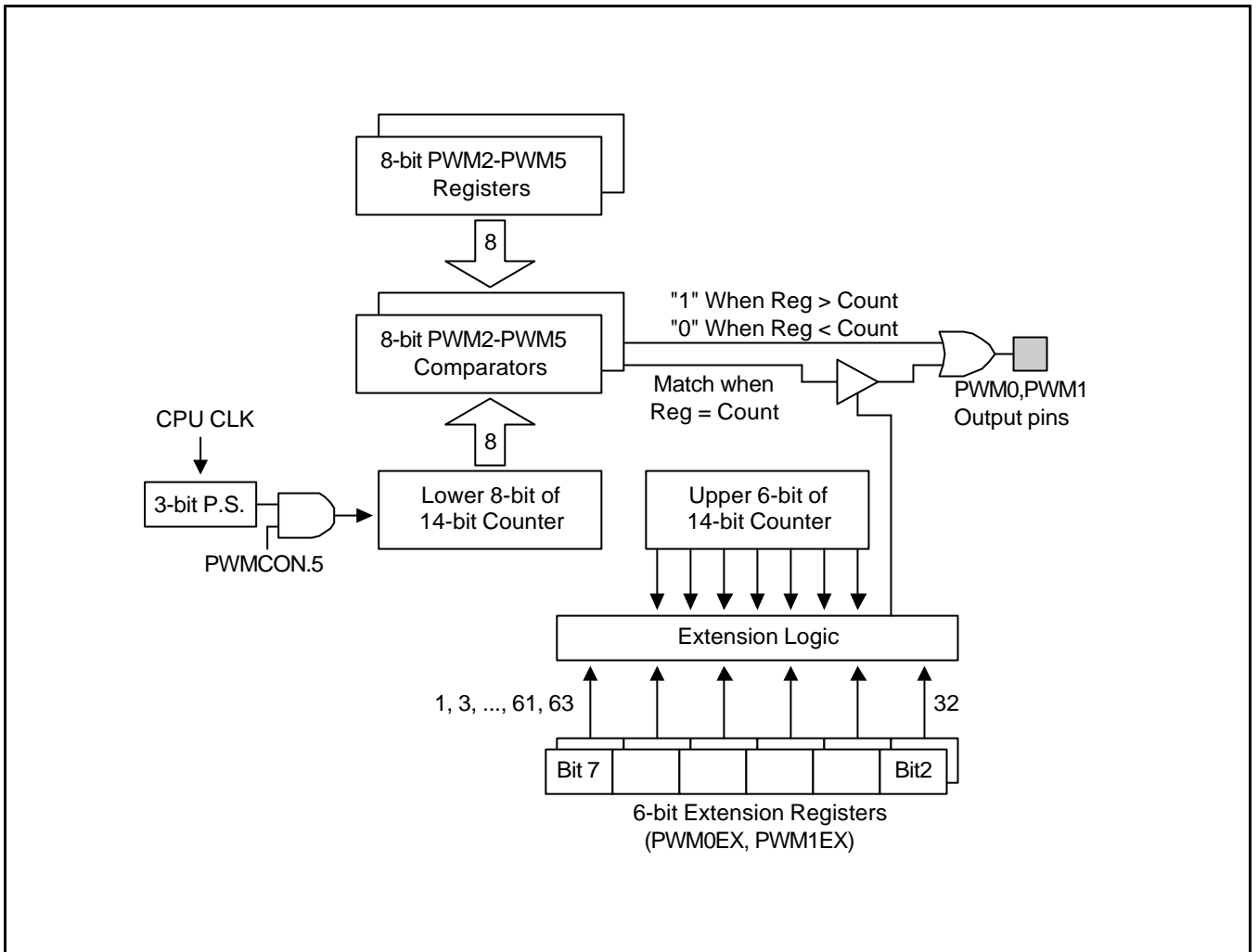


Figure 12-5. Block Diagram for PWM0 and PWM1

PROGRAMMING TIP — Programming PWM0 to Sample Specifications

This example shows how to program the 14-bit pulse-width modulation module, PWM0. The program parameters are as follows:

- The oscillation frequency of the main crystal is 6 MHz
- PWM0 data is in the working register R0
- PWM0EX (PWM0 extension value) is in the working register R1, bits 2–7

The program performs the following operations:

1. Set the PWM0 frequency to 23.437 kHz
2. If R3.0 = "1", then $PWM \leftarrow PWM + 12H$
(If an overflow occurs from R0, then $R0 \leftarrow 0FFH$ and $R1 \leftarrow 0FCH$.)
3. If R3.0 = "0", then $PWM \leftarrow PWM - 11H$
(If an underflow occurs from R0, then $R0 \leftarrow 00H$ and $R1 \leftarrow 00H$.)

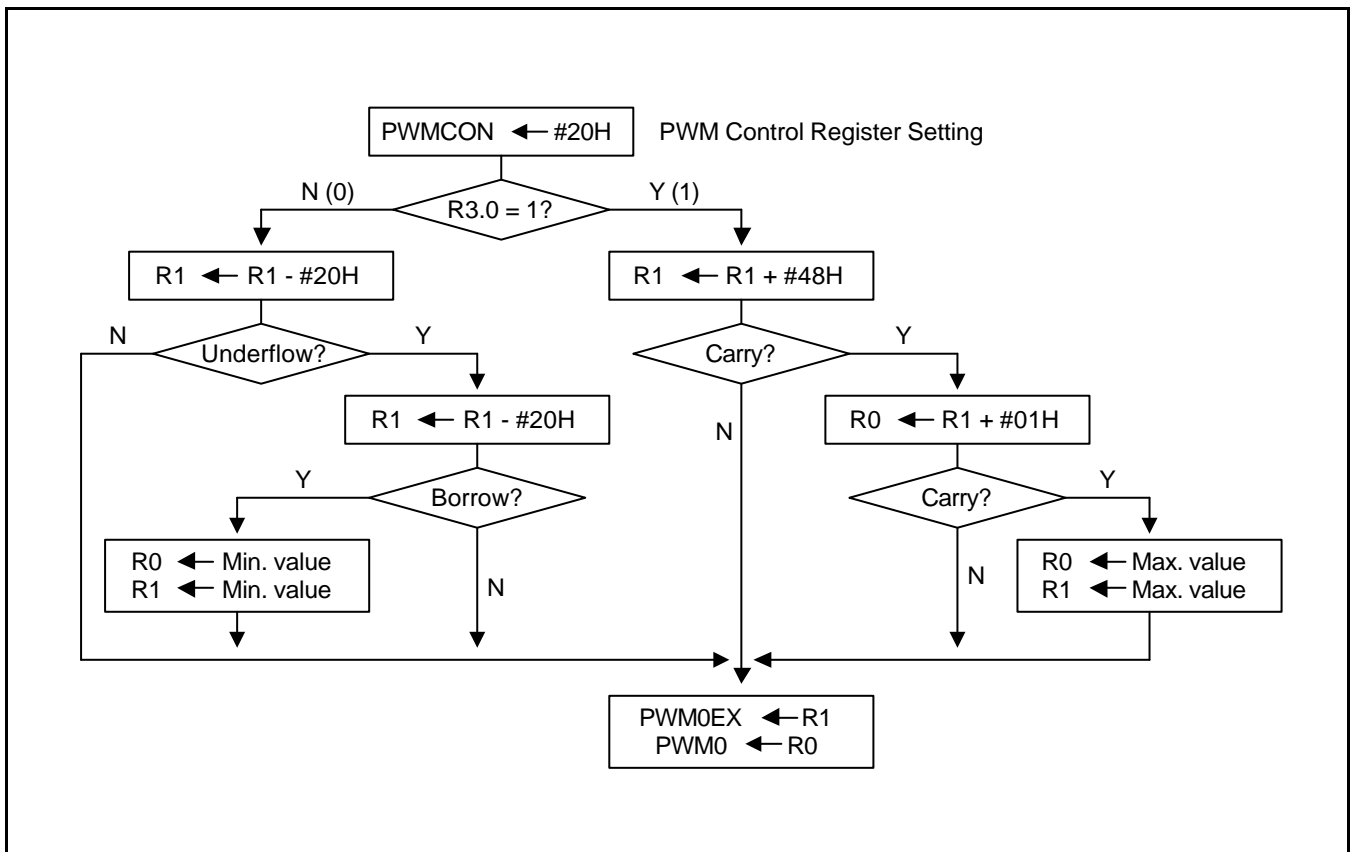


Figure 12-6. Decision Flowchart for PWM0 Programming Tip

 **PROGRAMMING TIP — Programming PWM0 to Sample Specifications (Continued)**

```

•
•
•
LD      PWMCON,#20H      ; PS ← 0 (Select 23.437-kHz PWM frequency)
                          ; Enable the PWM counter

```

```

•
•
•
BTJRF   pwm0_dec,R3.0    ; If R3.0 = "0", then jump to pwm0_dec

```

pwm0_inc:

```

ADD      R1,#48H          ; If R3.0 = "1", then add 48H to the PWM data
JR       NC,pwm0_data_end ; If no carry, go to pwm0_data_end
INC      R0                ; R0 ← R0 + 1
JR       NZ,pwm0_data_end ; If no overflow, jump to pwm0_data_end for update
LD       R0,#0FFH         ; If overflow, set 0FFH to R0
LD       R1,#0FCH         ; Set 0FCH to R1
JR       T,pwm0_data_end  ; Jump to pwm0_data_end unconditionally

```

pwm0_dec:

```

SUB      R1,#44H          ; R3.0 = "0", so subtract 44H from PWM data
JP       NC,pwm0_data_end ; If no borrow, jump to pwm0_data_end for update
SUB      R0,#01H         ; Decrement R0 (R0 ← R0 - 1)
JR       NC,pwm0_data_end ; If no borrow, jump to pwm0_data_end
CLR      R0                ; Clear data R0
CLR      R1                ; Clear data R1

```

pwm0_data_end:

```

LD       PWM0EX,R1        ; Load new value to PWM0EX (bits 2–7)
LD       PWM0,R0          ; Load new value to PWM0

```

```

•
•
•

```

CAPTURE UNIT

An 8-bit capture unit is integrated in the PWM module. The capture unit detects incoming signal edges and can be used to measure the pulse width of the incoming signals. PWMCON register settings control the capture unit, which has the following components:

- 8-bit capture data register (CAPA)
- Capture input pin (CAPA/Pin 36)
- 8-bit capture interrupt (IRQ3, vector 02H)

The capture unit captures the upper 8-bit value of the 14-bit counter when a signal edge transition is detected at the CAPA pin. The captured value is then dumped into the capture A data register, also called CAPA, where it can be read.

Using PWMCON.0 and PWMCON.1 settings, you can set edge detection at the CAPA pin for rising edges, falling edges, or for both signal edge types.

You can also use signal edges at the CAPA pin to generate an interrupt. PWMCON.3 is the capture A interrupt enable bit.

The capture interrupt is in the level 3 (IRQ3) and its vector address is 02H.

Using the capture A interrupt, you can read the contents of the CAPA data register from edge to edge and use the values to calculate the elapsed time between pulses.

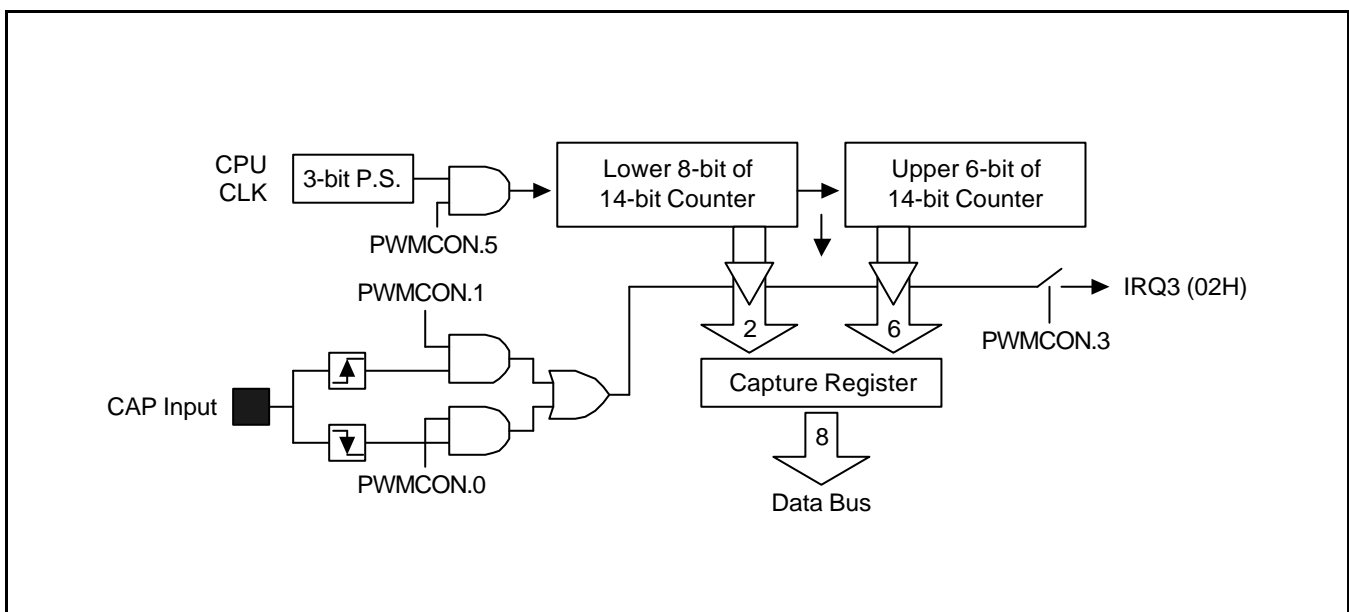
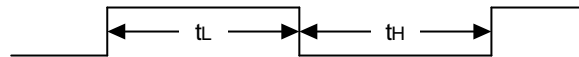


Figure 12-7. Block Diagram for Capture A

 **PROGRAMMING TIP — Programming the Capture Module to Sample Specifications**

This example shows you how to program the S3C880A/F880A capture A module. The sample parameters are as follows:

- The main oscillator frequency is 6 MHz
- Timer A interrupt occurs every 2 ms
- The following waveform is currently being input at the capture (CAPA) pin:



- The following registers are assigned for program values:

Register 70H	LDR	;	First captured count value
Register 71H		;	Second captured count value
Register 72H		;	Third captured count value
Register 73H	DWNCNT	;	Down-counter; decremented by 1 with each timer A interrupt
Register 74H	CAPCNT	;	Capture counter
Register 77H	FLAG	;	Flags

Here is some additional information about the sample program:

1. If $4.35 \text{ ms} < t_H, t_L < 4.6 \text{ ms}$, then set bit zero (LDR) in the register 77H; otherwise clear the zero bit (LDR) in the register 77H.
2. If the interval between two rising signal edges (capture trigger) is $> 30 \text{ ms}$, disregard the capture setting.

Figures 12-4 and 12-5 show decision flowcharts for the sample program.

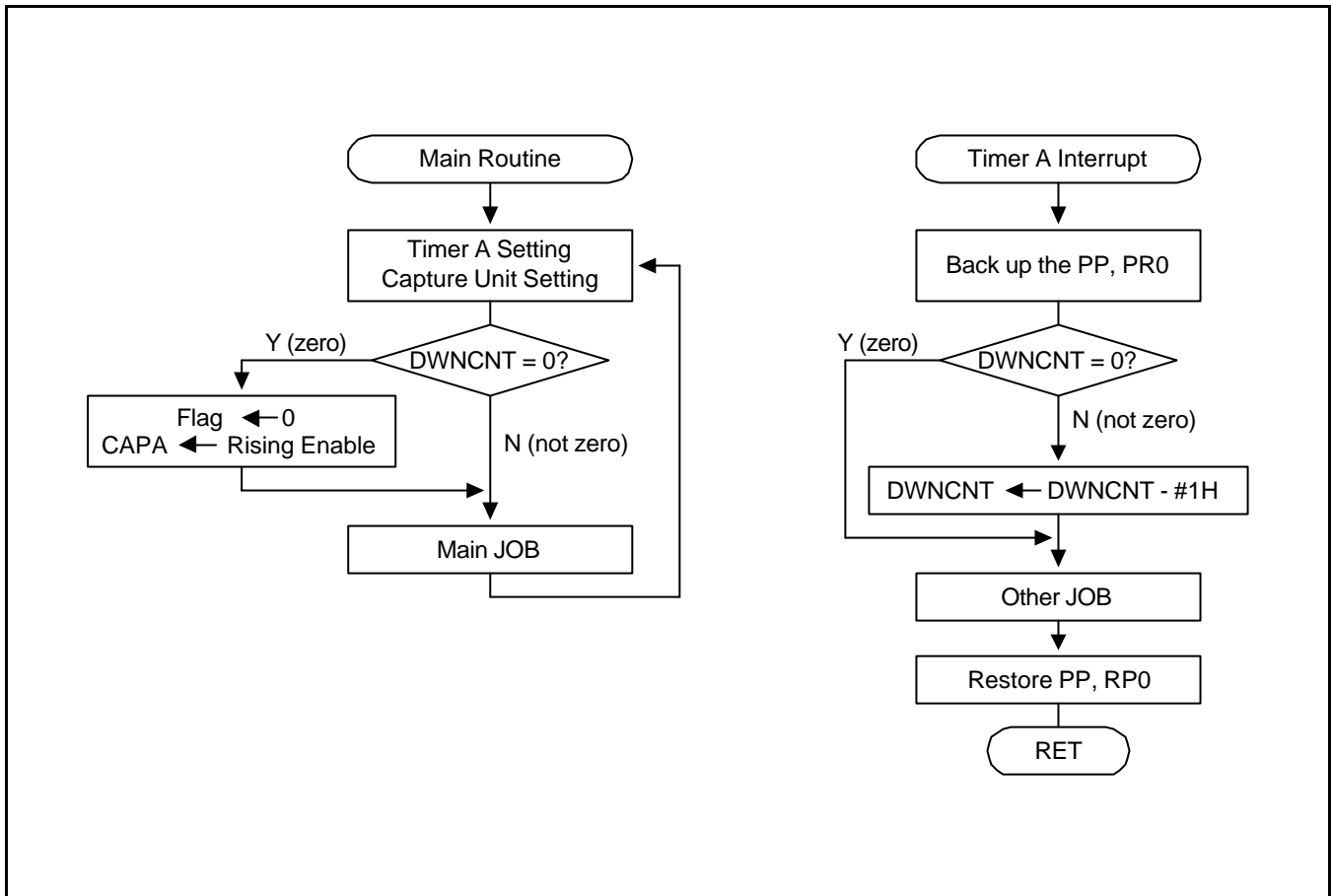


Figure 12-8. Decision Flowchart (Main Routine and Timer A Interrupt)

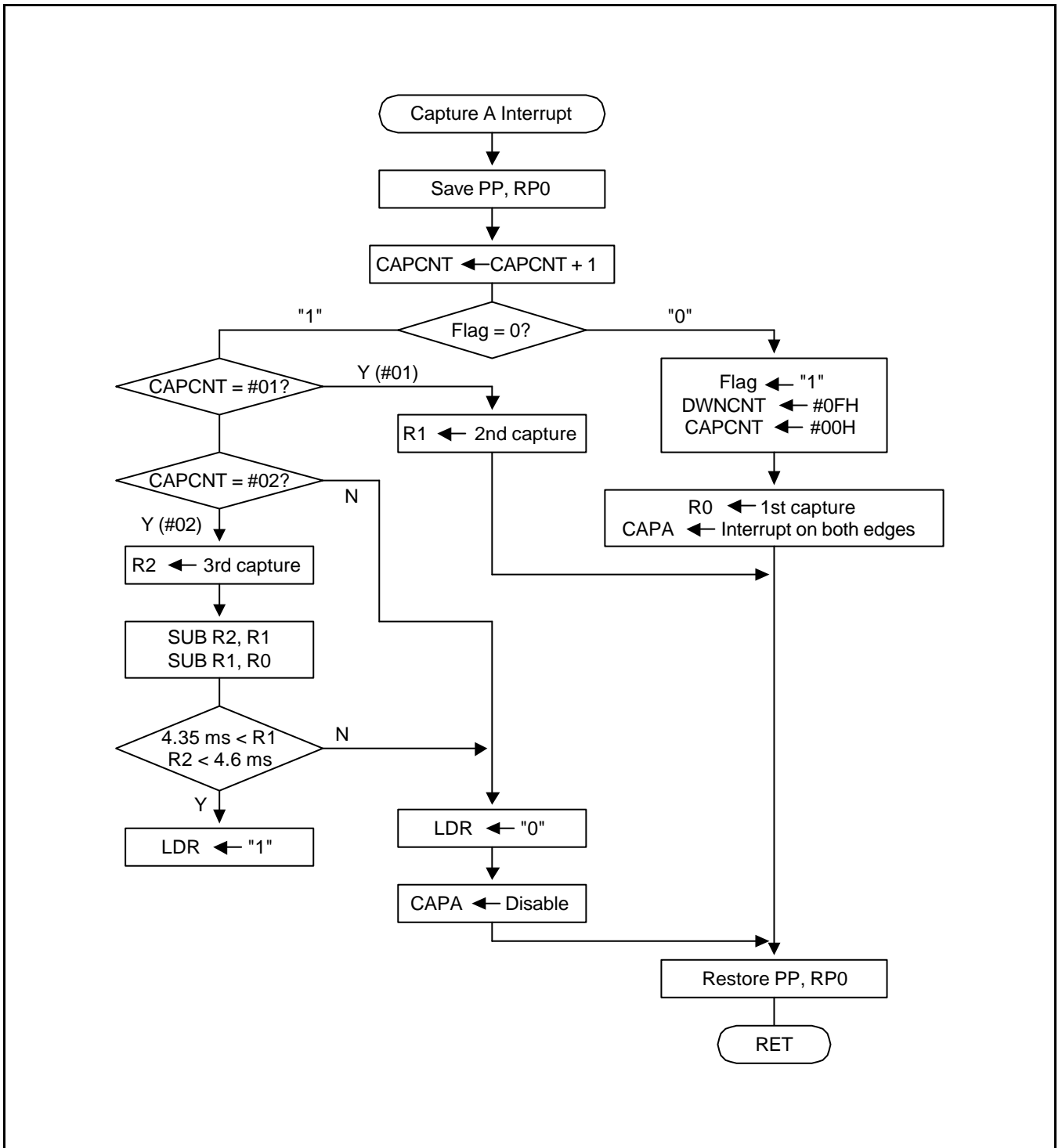


Figure 12-9. Decision Flowchart for Capture A Interrupt

 **PROGRAMMING TIP — Programming the Capture Module to Sample Specifications**

```

•
•
•
LDR    EQU    0
DWNCNT EQU    3
CAPCNT EQU    4
FLAG   EQU    7
•
•
•
CLR    PP                ; Select page 0
LD     TACON,#54H        ; PS ← 5, interval mode
                        ; Enable timer A interrupt
LD     TADATA,#01H      ; 2-ms interval (6 MHz /1000 ÷ 6 ÷ 2 = 0.5 kHz = 2 ms)
•
•
•
EXEC_MAIN:
SRP0   #70H              ; RP0 ← 70H
CP     RDWNCNT,#00H      ; Down-counter = "0"?
JP     NE,MAIN           ; If not zero, then jump to MAIN
BITR   R7.FLAG          ; Clear the 'FLAG'
LD     PWMCON,#0AH      ; Enable capture A interrupt
                        ; Trigger interrupt on rising edges
MAIN:  ; Other job...
•
•
•
JP     T,exec_main      ; For looping
•
•
•
TAINT  PUSH    PP        ; Save page pointer
      PUSH    RP0       ; Save register pointer 0
      SRP0   #70H       ; RP0 ← 70H
      CP     RDWNCNT,#00H ; R3 (down-counter) = "0"?
      JP     EQ,ta_exec  ;
      DEC    RDWNCNT     ; If not zero, then decrement R3 by 1
TA_EXEC:
•
•
•
POP    RP0              ; Restore register pointer 0
POP    PP               ; Restore page pointer
IRET                          ; Return from timer A interrupt service routine

```

(Continued on next page)

 **PROGRAMMING TIP — Programming the Capture Module to Sample Specifications (Continued)**

```

CAPINT    PUSH    PP                ; Save the page pointer to stack
          PUSH    RP0              ; Save register pointer 0 to stack
          SRP0    #70H             ; RP0 ← 70H
          INC     RCAPCNT           ; Increment the capture counter
          BTJRT   cap_one,R7.FLAG   ; R7.FLAG ← "1", then jump to cap_one
          BITS    R7.FLAG           ; Set R7.FLAG
          CLR     RCAPCNT           ; Clear capture counter
          LD      RDWNCNT,#0FH      ; Down-counter ← 15 (for counting 30 ms)
          LD      R0,CAPA           ; R0 ← 1st captured count value
          LD      CAPA = 0F9H, page 0 ; CAPA = 0F9H, page 0
          LD      PWMCON,#0BH       ; Enable capture interrupt
          ; Trigger interrupt on both rising and falling edges

CAP_END   POP     RP0              ; Restore the register pointer 0 value
          POP     PP                ; Restore the page pointer value
          IRET

CAP_ONE   CP      RCAPCNT,#01H      ; CAPCNT = #01H?
          JP      NE,cap_con2       ;
          LD      R1,CAPA           ; R1 ← 2nd captured count value
          JR      T,cap_end         ;

CAP_CON2  CP      RCAPCNT,#02H      ; CAPCNT = #02H?
          JP      EQ,cap_con3       ;

CAP_CON4  BITR    R7.LDR            ; Clear the LDR bit in R7
CAP_CON5  LD      PWMCON,#00H      ; Disable the capture module
          JR      T,cap_end         ;

```

(Continued on next page)

👉 **PROGRAMMING TIP — Programming the Capture Module to Sample Specifications (Concluded)**

```

CAP_CON3 LD      R2,CAPA      ; R2 ← 3rd capture count value
          SUB     R2,R1       ; R2 ← (3rd capture value – 2nd capture value)
          SUB     R1,R0       ; R1 ← (2nd capture value – 1st capture value)
          CP      R1,#24H     ; 24H = 4.6 ms

          JP      UGT,cap_con4 ; If High signal period > 4.6 ms, then go to cap_con4
          CP      R2,#24H     ;
          JP      UGT,cap_con4 ; If Low signal period > 4.6 ms, then go to cap_con4

          CP      R1,#22H     ; 22H = 4.35 ms

          JP      ULT,cap_con4 ; If High signal period < 4.35 ms, then go to cap_con4
          CP      R2,#22H     ;
          JP      ULT,cap_con4 ; If Low signal period < 4.35 ms, then go to cap_con4

          BITS    R7.LDR      ; Set bit 'LDR'
          JP      T,cap_con5   ; Jump to cap_con5 unconditionally
          .
          .
          .

```

13 ON-SCREEN DISPLAY (OSD)

OVERVIEW

The on-screen display (OSD) module displays channel number, the time, and other information on a display screen. The OSD character display module has 252 locations and supports a set of maximum 1024 characters. (Two characters are reserved: 00H for the blank function and 01H for the test pattern.) There are sixty four display colors.

PATTERN GENERATION SOFTWARE

For application development using the S3C880A/F880A microcontrollers, Samsung provides OSD pattern generation software (OSDFONT.exe). You can customize standard OSD patterns contained in this file.

Table 13-1. OSD Function Block Summary

OSD Function Block	Function Description
Video RAM (note)	Located in register page 1, the video RAM contains 252 "word" lines. Each line is 14 bits long. Each 14-bit RAM address stores an 10-bit character code, a character halftone or character background color display control bit, and a 3-bit color code. Video RAM locations can be read or written: 00H–BFH can be accessed using any addressing mode; C0H–FBH can be accessed using Indirect Register or Indexed addressing mode only.
Character ROM	The character ROM contains an 18-dot × 16-dot matrix data for 1024 characters. It is synchronized with the internal dot clock. The ROM outputs the dot matrix data for each character. The function of two characters is pre-determined: 00H is used for blank (no-display) data and 01H is for a factory test pattern.
Output control logic	Output control logic receives input from the Character ROM, OSD control registers, and fade control circuits. It then decides what to display on the screen and what color the display should be. On the basis of truth table calculations, the final OSD signals (blue, green, red, blank, and H/T) are output from the OSD block at pins 22–25, 21.

NOTE: The video RAM can be cleared only by "LD" instruction.

INTERNAL OSD CLOCK

Red-green-blue (RGB) color outputs, as well as display rates and positions, are determined by the clock signal, DOT_CLK. This signal is generated by the L-C oscillator and is scaled by the dot and column counter. DOT_CLK equals the OSD oscillator clock divided by the clock divider value. The clock divider value is set by the horizontal character size settings in the CHACON register.

The rate at which each new display line is generated is determined by H-sync input. The rate at which each new frame (screen) is generated is determined by V-sync input. For stable on screen display operation, the CPU clock frequency should be faster than OSD clock.

OSD VIDEO RAM

The OSD video RAM contains 252 word lines. Each line is 14 bits long. Of these 14 bits, eight are character display codes (bits 0-9). Bit 13 is the character halftone or character background color display control bit and bits 10-12 are used to determine the red, green, and blue components of the character color.

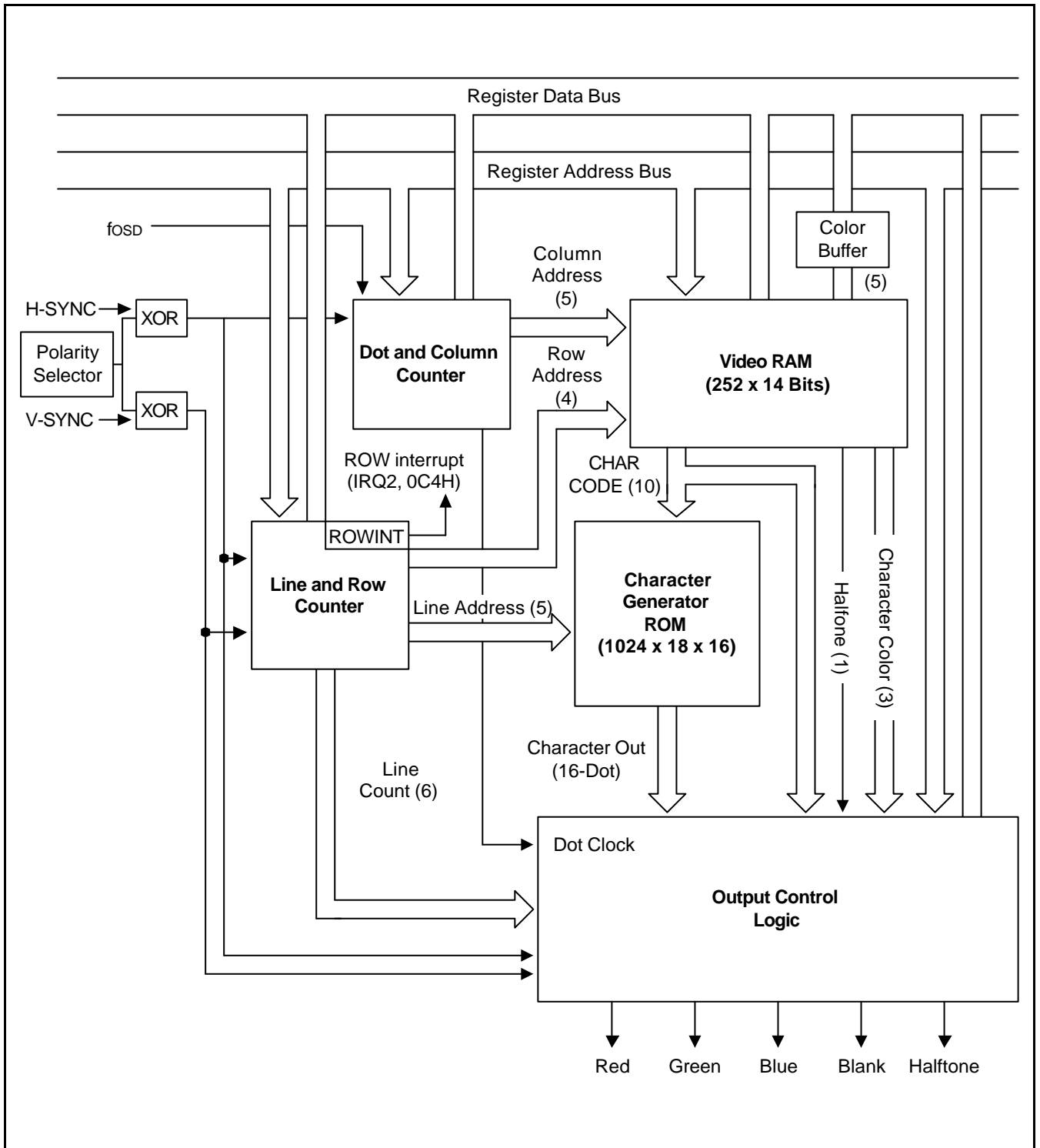


Figure 13-1. On-Screen Display Function Block Diagram

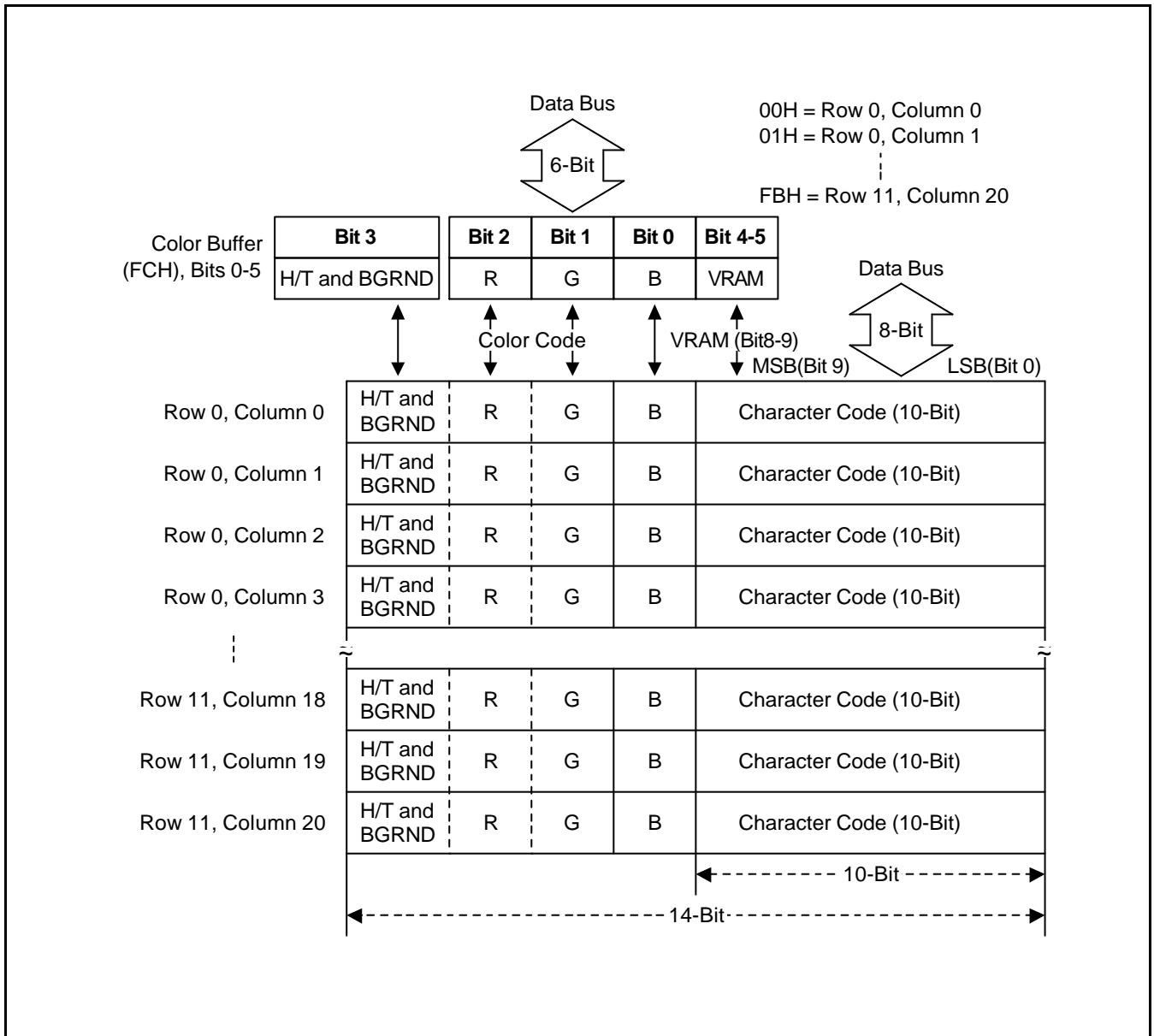


Figure 13-2. On-Screen Display Video RAM Data Organization

OSD CONTROL REGISTER OVERVIEW

Seven control registers are used to control specific functions of the on-screen display module:

There are seven control registers for OSD functions and one color buffer register:

DSPCON	Display control register
CHACON	Character size and fade control register
FADECON	Fade control register
ROWCON	Row display position and inter-row spacing control register
CLMCON	Column display position and inter-column spacing control register
COLCON	Background color control register
HTCON	Halftone signal control register
COLBUF	Character color buffer register
VSBCON	V-sync blank time control register
OSDFRG1/2	Fringe or border control registers
OSDSMH1/2	Smooth display control registers
OSDCOL	OSD factor control register
OSDFLD	Field control register
OSDPLTR1/2	Palette color mode Red 1/2
OSDPLTG1/2	Palette color mode Green 1/2
OSDPLTB1/2	Palette color mode Blue 1/2

These registers are described in this section within the context of the OSD hardware module description. For detailed quick-reference descriptions of the control register bit settings, please refer to Section 4, "Control Registers."

DISPLAY CONTROL REGISTER (DSPCON)

Settings in the display control register, DSPCON (F5H, set 1, bank 1), are used to enable and disable the on-screen display to select halftone or background color for character displays, choose the polarity for H-sync and V-sync signal synchronization, and as OSD ROW counter which is read-only (bit4–bit7).

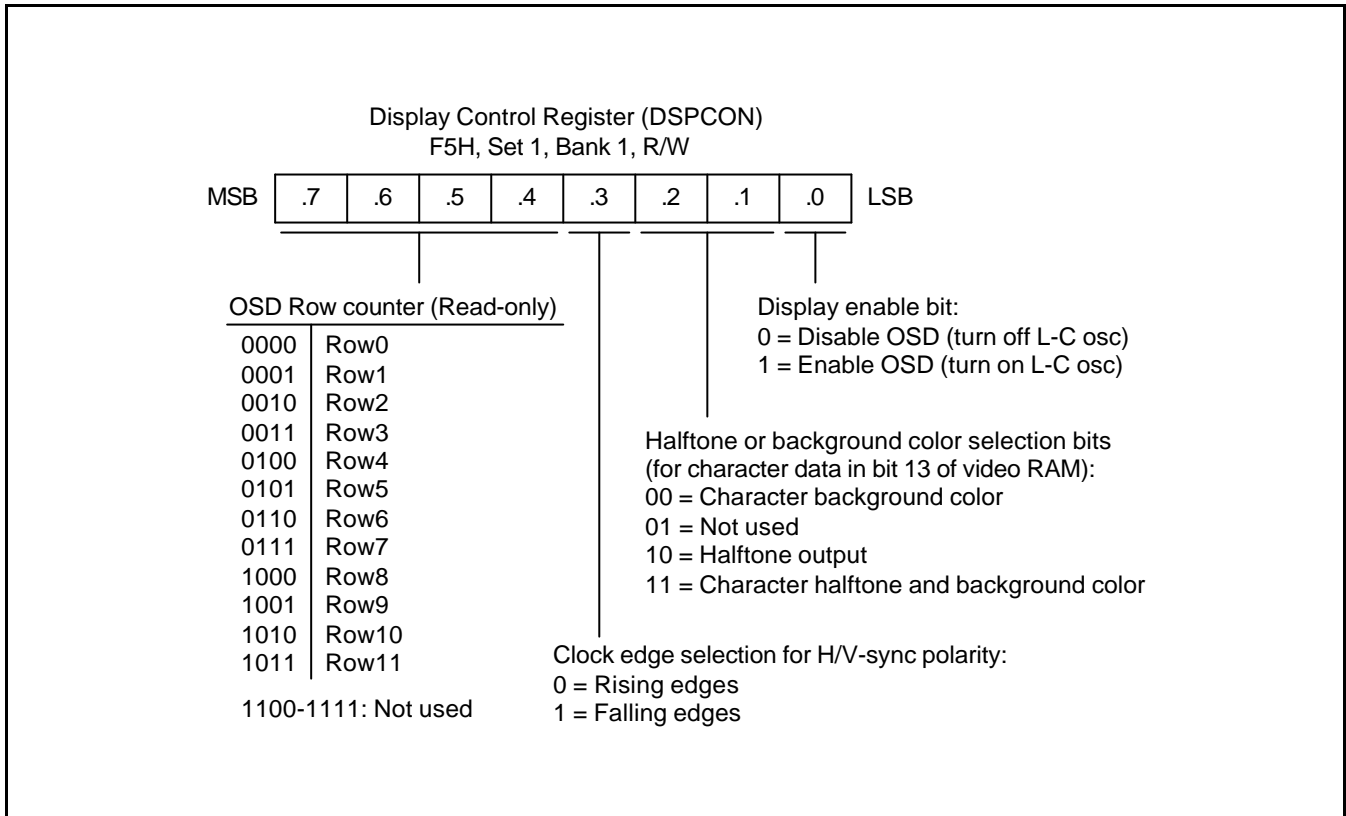


Figure 13-3. OSD Display Control Register (DSPCON)

NOTE

Refer to the PROGRAMMING TIP – Row Interrupt Function of 13-24.

OSD Enable/Disable

The DSPCON.0 setting enables or disables the on-screen display module. To enable the OSD (turn L-C oscillation on), set DSPCON.0 to "1"; to disable OSD (turn L-C oscillation off), clear DSPCON.0 to "0". When you do not use the display module, we recommend that you keep DSPCON.0 cleared to "0" in order to reduce possible noise generation by the L-C oscillator.

The DSPCON.0 settings determine the on/off condition of L-C oscillation, synchronized with Vsync input. And the OSD output can be turned on or off in OSD row units when L-C oscillation is on. At the point the value of DSPCON.0 is changed from "1" to "0" in the middle of a frame, OSD is disabled (OSD output is off). In this condition, L-C oscillation becomes off at the next Vsync input. When the value is shifted from "0" to "1", OSD is enabled (OSD output is on) and L-C oscillation returns to "on" at the following Vsync input.

H-Sync and V-Sync Polarity Selection

DSPCON.3 selects the triggering edge of H-sync and V-sync inputs to the OSD block. Incoming sync pulses enter a polarity option circuit that is controlled by the SYNC bit. If DSPCON.3 = "0", rising edges are selected; if it is "1", falling edges are selected.

Character Halftone or Character Background Color Selection

DSPCON.2 and DSPCON.1 let you select a halftone or background color display for individual characters. (Which characters are displayed as halftones, or with character background color, or with character halftone, or with character background color, or with character halftone and background color, depends on the bit 13 settings in the character video RAM data)

When DSPCON.2-.1 = "00", the character background color option is selected; when DSPCON.2-.1 = "10", the character halftone function is selected; when DSPCON.2-.1 = "11", the character halftone and background color option are selected; but DSPCON.2-.1 = "01" is not used.

ROW Counter Function

DSPCON.4–DSPCON.7 to the OSD ROW read data. OSD ROW counter indicates the OSD ROW currently displayed. One ROW comprises one character (18 lines) and inter-ROW space (ROWCON.2–.0). The Row counter value for the first ROW after a Vsync input is set to "0".

CHARACTER SIZE CONTROL REGISTER (CHACON)

Using the character size control register, CHACON, you can specify four different standard character sizes in both vertical and horizontal directions. You also use the CHACON register to select rows (0–11) for the character fade function (see Figure 13-5).

Vertical character size is defined by bits 6 and 7 of the CHACON register; horizontal direction is defined by bits 4 and 5. There are four basic character size settings: x1, x2, x3, and x4. Size 'x1' is the smallest and 'x4' is the largest. For example, to display a 'x1' (horizontal) by 'x1' (vertical) size character, you should clear CHACON.4–CHACON.7 to "0". To display a 'x4' by 'x4' size character, you should set bits 4–7 to '1111B'.

You can also combine different vertical and horizontal size selections to produce flattened or elongated characters (see Figure 13-5).

"1 dot" is a minimum unit of character size. 1 character is composed of 16 dots in width and 18 dots in length. 1 dot in width is 1 fosc clock and 1 dot in length is 1 H-sync line. 1 dot of 1x1 character size (minimum unit) is composed of 1 fosc clock and 2 H-sync line (even + odd field).

Character size in width is increased by 1 clock. So x1, x2, x3, and x4 in width are the same as 1, 2, 3 and 4 clock, respectively. Character size in length is increased by 2 H-sync line (even field + odd field), so x1 and x2 in length are the same as 2 H-sync line (even field + odd field) and 4 H- sync line (even field + odd field + even field + odd field), respectively. Half dot in width is 1/2 fosc clock, and 1/2 dot in length is 1 H-sync line (even or odd field).

In the fringe and boarder function, 1/2 dot setting can be used. So, please be more careful in using the 1/2 dot to prevent the blink. (Because the character size is changed in 1 dot unit or set to 1/2 dot in fringing or boarder function, blinking can occur in interlace scan, so care must be taken when 1/2 dot is used for width.)

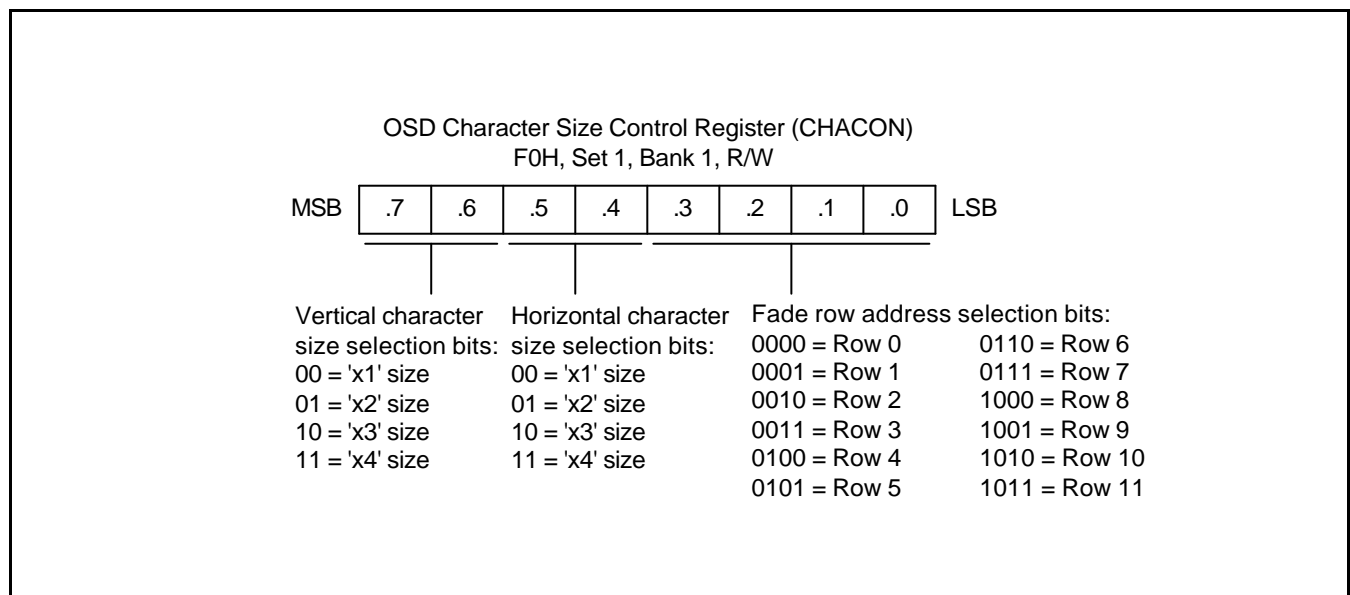


Figure 13-4. OSD Character Size Control Register (CHACON)

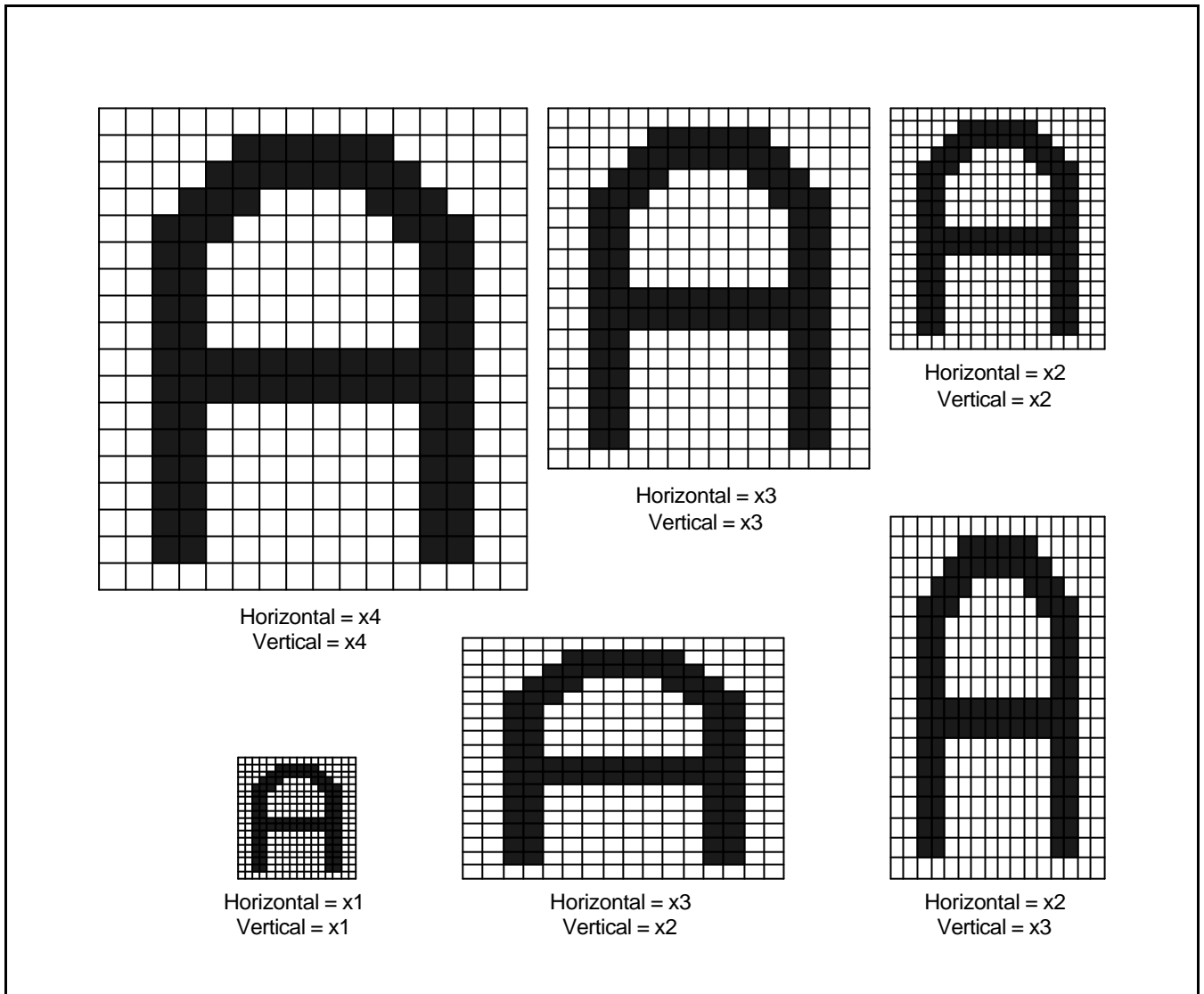


Figure 13-5. OSD Character Sizing Dimensions

FADE-IN AND FADE-OUT CONTROL REGISTER (FADECON)

The OSD block lets you program fade-in and fade-out displays. A *fade-in display* is one in which a character matrix is displayed incrementally until the complete character "appears". A *fade-out display* shows the complete character matrix first and then decrements the matrix line-by-line until the character "disappears" from the display field.

The address of the character display (and the specific line) to be faded-in or faded-out is selected by writing bit values into the CHACON and FADECON registers. Bits 3–0 in the CHACON register specify the 4-bit video RAM address of one of the twelve rows (0–11) of the fade display. Bits 0–4 in the FADECON register specify the 5-bit line address within the selected row.

Fade direction is controlled by FADECON.5. There are two choices of fade direction: before (FADECON.5 = "0") and after (FADECON.5 = "1"). When you select *fade before*, the character matrix is faded starting with line 0. When you select *fade after*, the matrix is faded starting with inter-row space line 6. (The inter = row space line 6 start position is only a suggestion, however, as the fade interval is assignable by software.) To enable the fade function, you should set FADECON.6 to "1". (FADECON.7 is not used).

NOTE

To avoid confusion in determining fade row and line addresses in the CHACON and FADECON registers, please note that *line* is a horizontal value that encompasses the entire character display field while *row* is a horizontal value for the character display matrix.

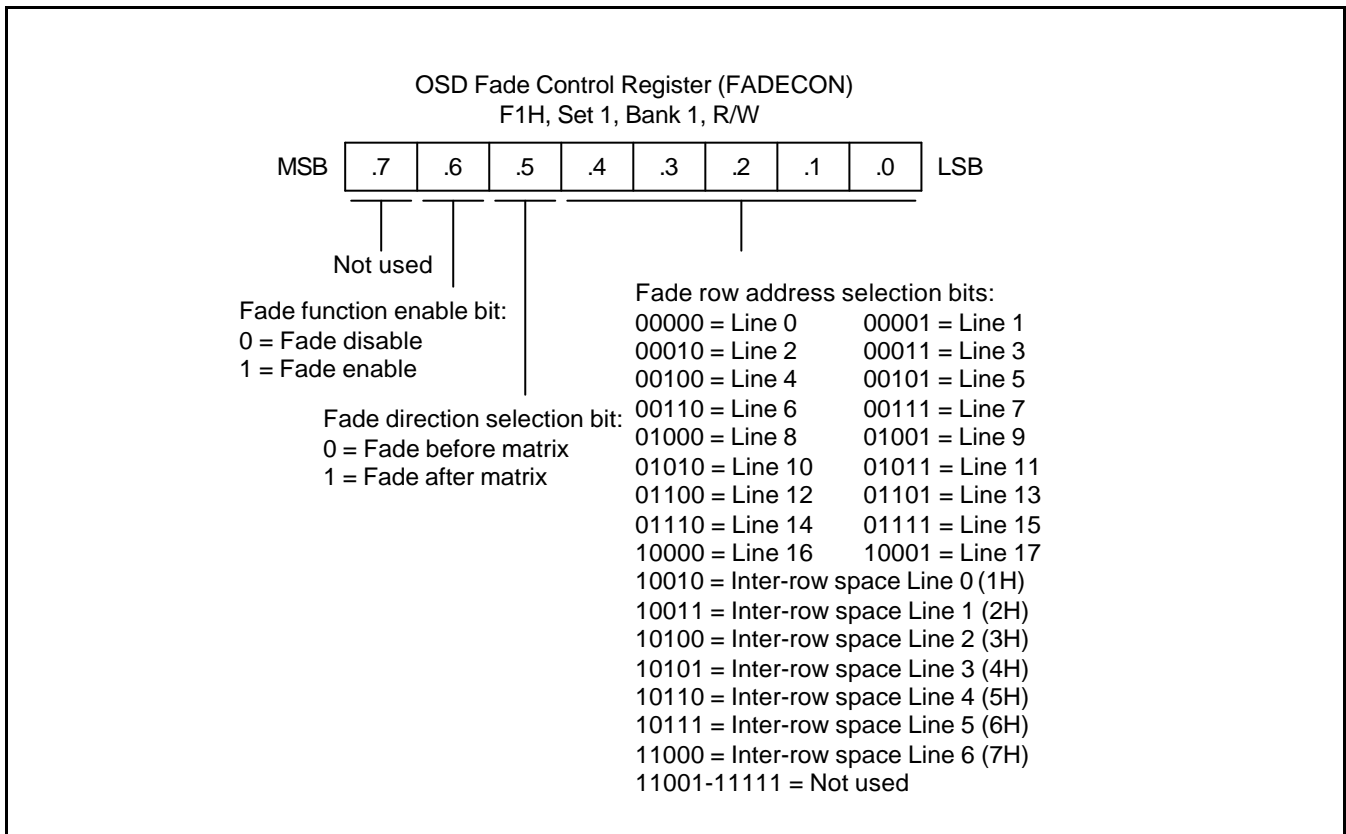


Figure 13-6. OSD Fade Control Register (FADECON)

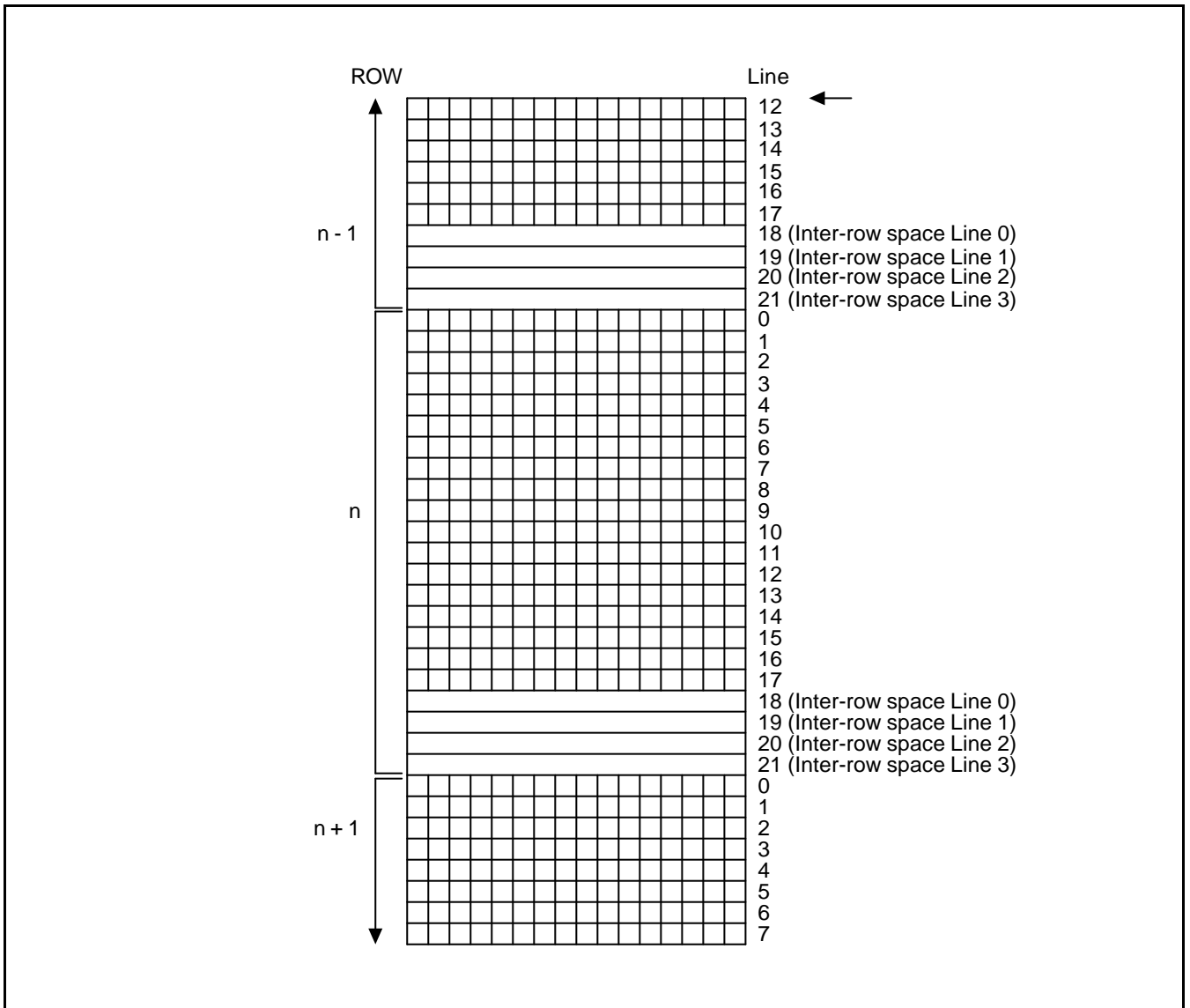


Figure 13-7. Line and Row Addressing Conventions when ROWCON.2-0 = "100"

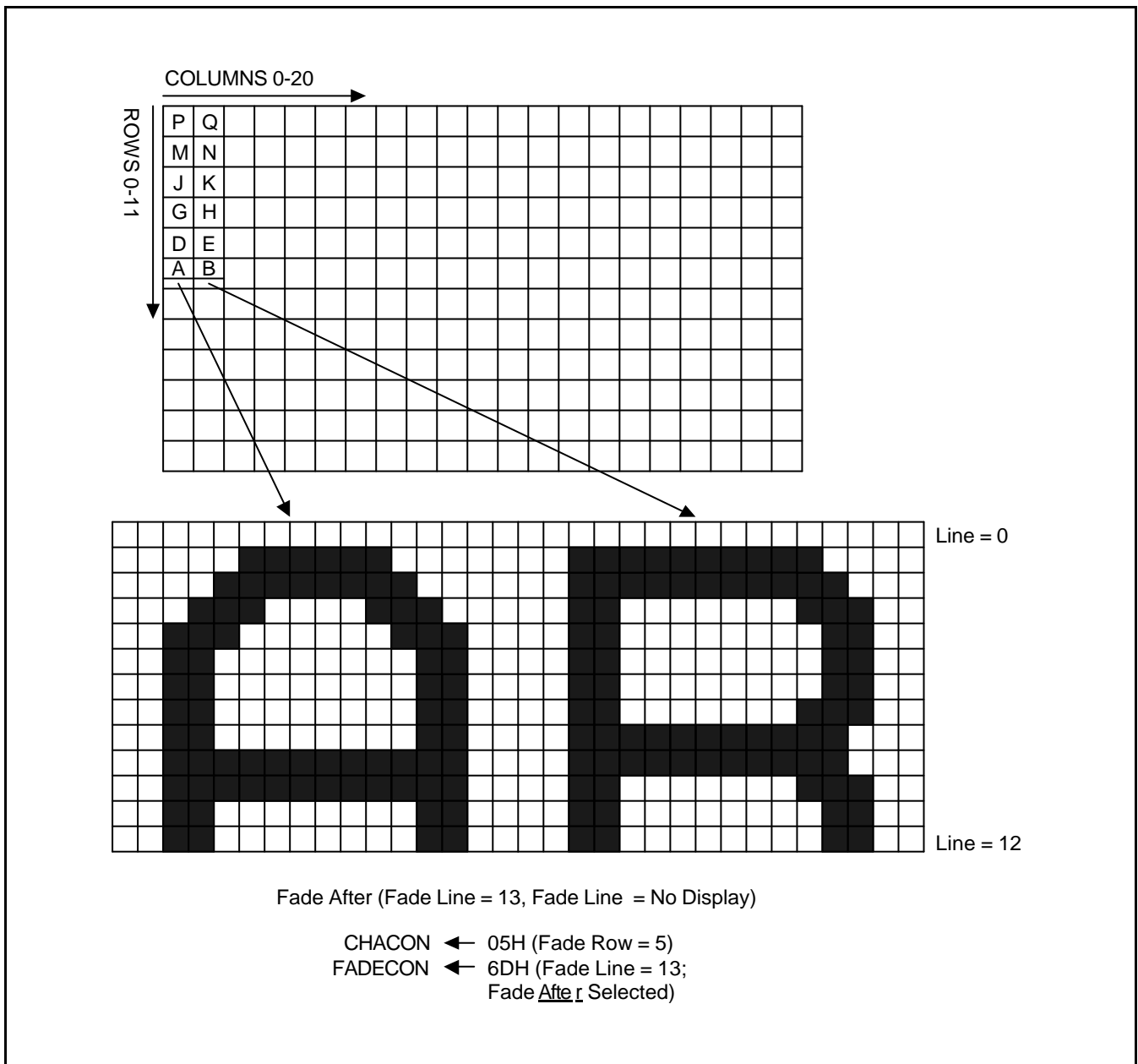


Figure 13-8. OSD Fade Function Example: Fade After

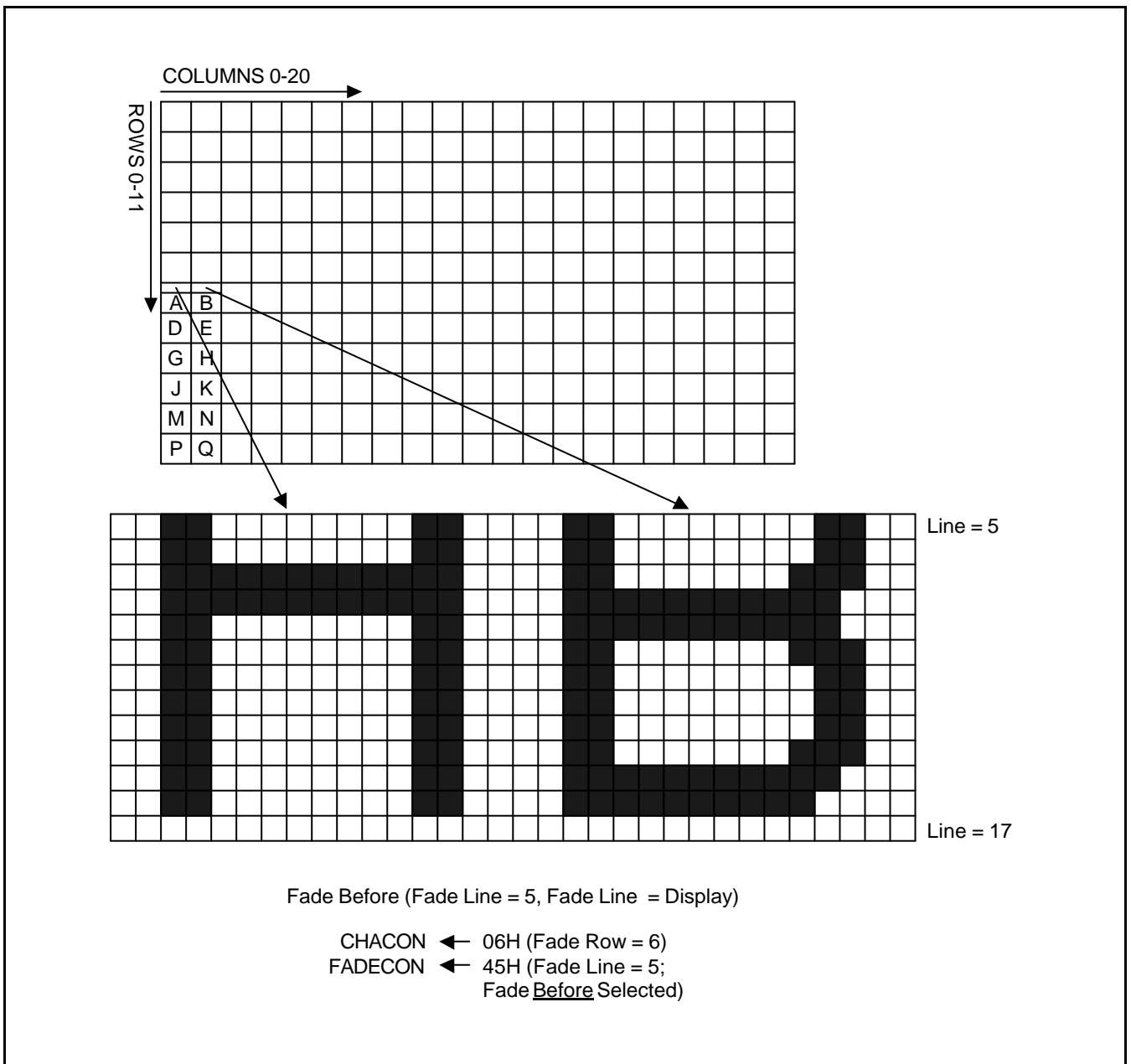


Figure 13-9. OSD Fade Function Example: Fade Before

DISPLAY POSITION CONTROL

The on-screen display has 252 character display positions. There are 21 horizontal columns and 12 vertical rows. Positions can be numbered sequentially from 0–251 (decimal) or from 0–FB (hexadecimal), as shown in Figures 13-11 and 13-12. To control display position, you can adjust the top and left margins and the inter-column and inter-row spacing between characters on the screen.

		COLUMNS 0-20																				DECIMAL																					
		0	1	2	3	4	5	6	7	8	9	10	11	12	13	14	15	16	17	18	19	20																					
ROWS 0-11	0	0	1	2	3	4	5	6	7	8	9	10	11	12	13	14	15	16	17	18	19	20	21	22	23	24	25	26	27	28	29	30	31	32	33	34	35	36	37	38	39	40	41
	1	42	43	44	45	46	47	48	49	50	51	52	53	54	55	56	57	58	59	60	61	62	63	64	65	66	67	68	69	70	71	72	73	74	75	76	77	78	79	80	81	82	83
	2	84	85	86	87	88	89	90	91	92	93	94	95	96	97	98	99	100	101	102	103	104	105	106	107	108	109	110	111	112	113	114	115	116	117	118	119	120	121	122	123	124	125
	3	126	127	128	129	130	131	132	133	134	135	136	137	138	139	140	141	142	143	144	145	146	147	148	149	150	151	152	153	154	155	156	157	158	159	160	161	162	163	164	165	166	167
	4	168	169	170	171	172	173	174	175	176	177	178	179	180	181	182	183	184	185	186	187	188	189	190	191	192	193	194	195	196	197	198	199	200	201	202	203	204	205	206	207	208	209
	5	210	211	212	213	214	215	216	217	218	219	220	221	222	223	224	225	226	227	228	229	230	231	232	233	234	235	236	237	238	239	240	241	242	243	244	245	246	247	248	249	250	251

Figure 13-10. 252-Byte On-Screen Character Display Map (Decimal)

		COLUMNS 0-20																				HEXADECIMAL																					
		0	1	2	3	4	5	6	7	8	9	A	B	C	D	E	F	10	11	12	13	14																					
ROWS 0-11	0	0	1	2	3	4	5	6	7	8	9	A	B	C	D	E	F	10	11	12	13	14	15	16	17	18	19	1A	1B	1C	1D	1E	1F	20	21	22	23	24	25	26	27	28	29
	1	2A	2B	2C	2D	2E	2F	30	31	32	33	34	35	36	37	38	39	3A	3B	3C	3D	3E	3F	40	41	42	43	44	45	46	47	48	49	4A	4B	4C	4D	4E	4F	50	51	52	53
	2	54	55	56	57	58	59	5A	5B	5C	5D	5E	5F	60	61	62	63	64	65	66	67	68	69	6A	6B	6C	6D	6E	6F	70	71	72	73	74	75	76	77	78	79	7A	7B	7C	7D
	3	7E	7F	80	81	82	83	84	85	86	87	88	89	8A	8B	8C	8D	8E	8F	90	91	92	93	94	95	96	97	98	99	9A	9B	9C	9D	9E	9F	A0	A1	A2	A3	A4	A5	A6	A7
	4	A8	A9	AA	AB	AC	AD	AE	AF	B0	B1	B2	B3	B4	B5	B6	B7	B8	B9	BA	BB	BC	BD	BE	BF	C0	C1	C2	C3	C4	C5	C6	C7	C8	C9	CA	CB	CC	CD	CE	CF	D0	D1
	5	D2	D3	D4	D5	D6	D7	D8	D9	DA	DB	DC	DD	DE	DF	E0	E1	E2	E3	E4	E5	E6	E7	E8	E9	EA	EB	EC	ED	EE	EF	F0	F1	F2	F3	F4	F5	F6	F7	F8	F9	FA	FB

Figure 13-11. 252-Byte On-Screen Character Display Map (Hexadecimal)

ROW CONTROL REGISTER (ROWCON)

The row control register, ROWCON, controls the top margin and inter-row spacing. *Top margin* is the distance (in H-sync pulses) to the top row of a character display from the top edge of its display frame. *Inter-row spacing* is the distance (in H-sync pulses) between two rows of displayed characters. The inter-row spacing value you select is applied equally to all rows in the display.

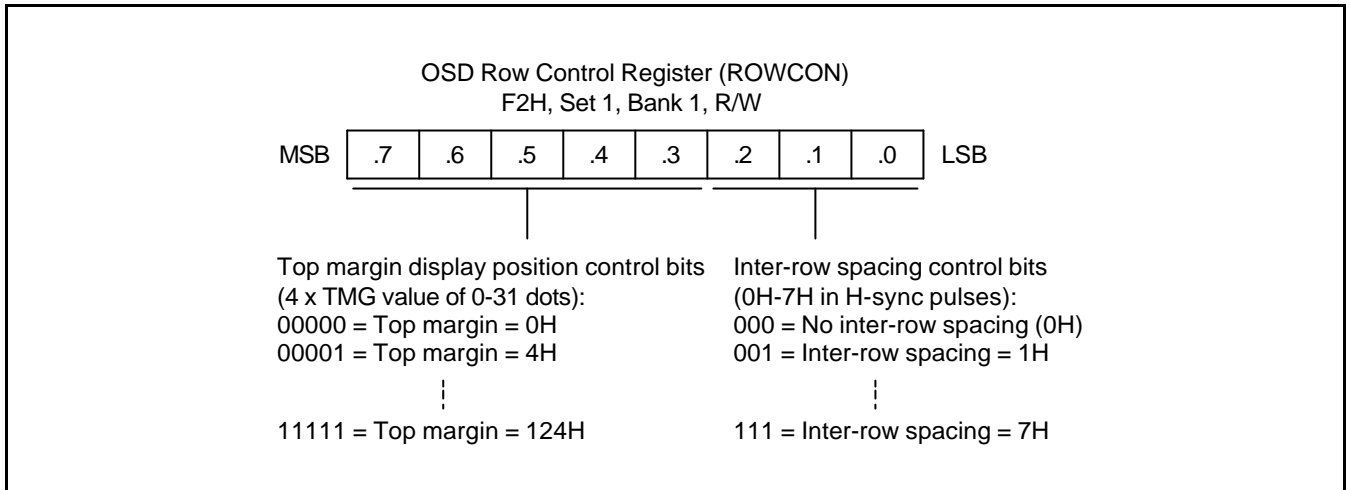


Figure 13-12. OSD Row Control Register (ROWCON)

COLUMN CONTROL REGISTER (CLMCON)

The column control register, CLMCON, controls the left margin and inter-column spacing. *Left margin* is the distance to the character display from the left edge of the display frame. *Inter-column spacing* is the distance (0-7 dots) between space separating the characters displayed in a row. The inter-column spacing value that you select is applied equally to all columns in the display.

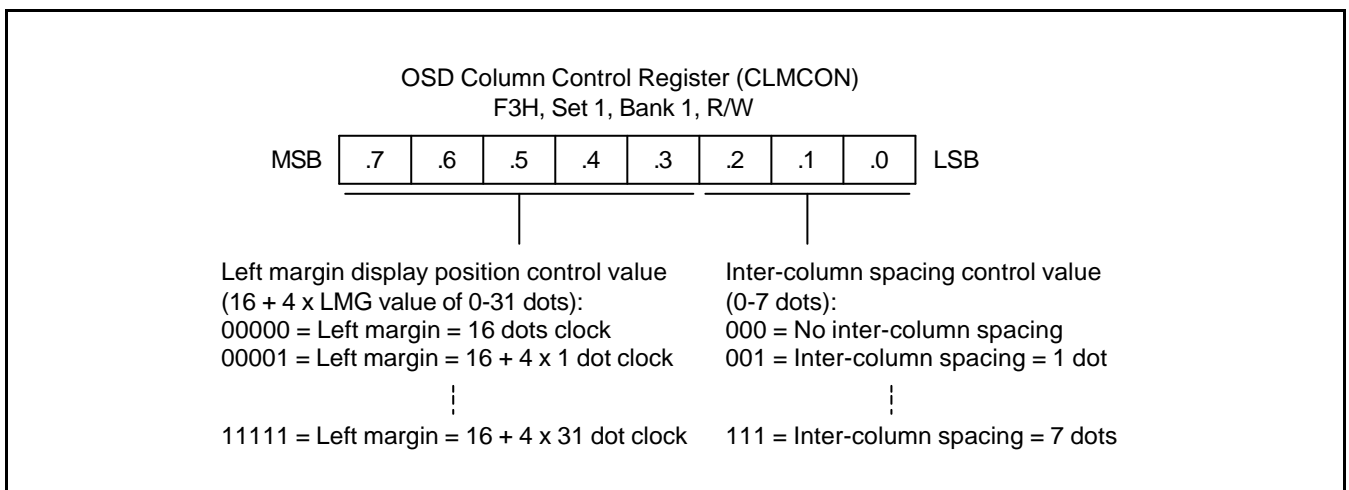


Figure 13-13. OSD Column Control Register (CLMCON)

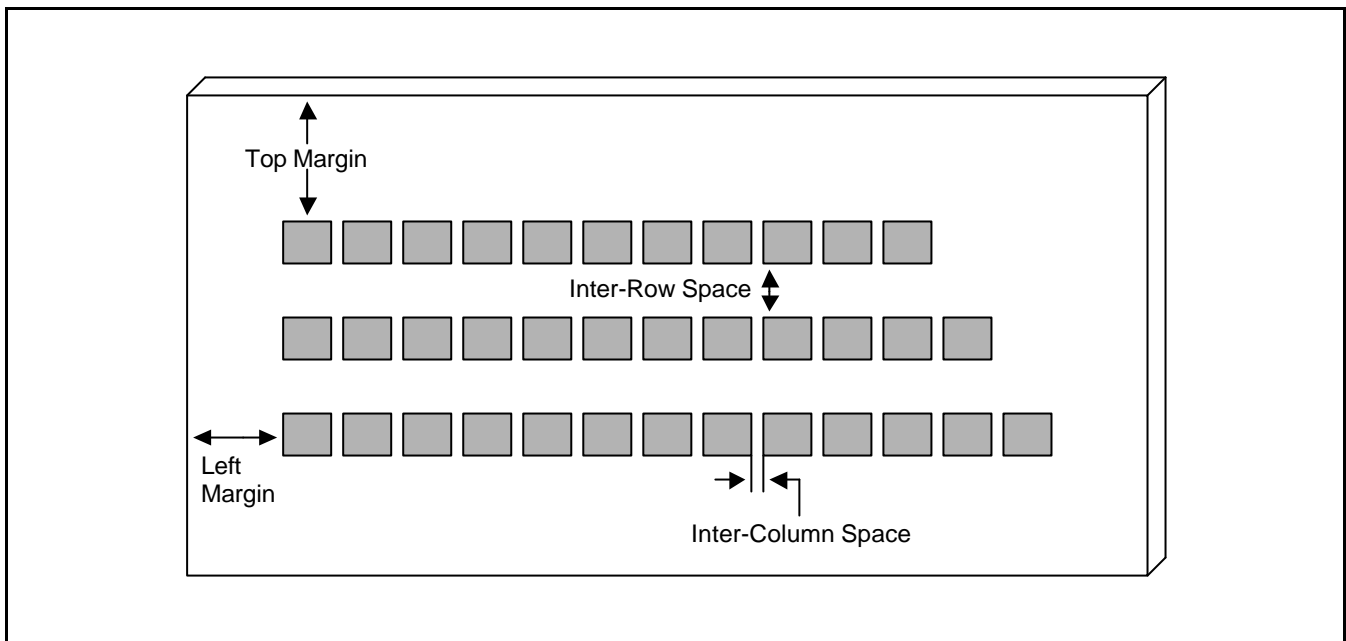


Figure 13-14. OSD Display Formatting and Spacing Conventions

Calculating Row and Column Spacing

Inter-row spacing and inter-column spacing are controlled by the ROWCON and CLMCON registers. You can select from zero to seven dots of spacing.

For inter-row spacing, the desired spacing value (0–7) is written to bits 0–2 of the ROWCON register. For inter-column spacing, the desired spacing value (0–7) is written to bits 0–2 of the CLMCON register.

Calculating Margin Settings

By writing a value to ROWCON.3–ROWCON.7, you can set the top margin at $4 \times$ the top margin dot value (TMG). Because TMG is a 5-bit value, you can select any dot value in the range 0–31.

By writing a value to CLMCON.3–CLMCON.7, you can set the left margin at $16 + 4 \times$ the left margin dot value (LMG). Because LMG is a 5-bit value, you can select any dot value in the range 0–31. The zero position for the left margin is always 16 dots.

- Top margin = $4 \times$ (top margin register value) H
- Left margin = $16 + 4 \times$ (left margin register value) dot clock
- Inter-column space = (Register value) dot clock
- Inter-row space = (Register value) H

CHARACTER COLOR CONTROL REGISTER (COLBUF)

The color of the character matrix display is controlled by manipulating a 5-bit value in the OSD video RAM. You can modify the *character color selection bits* only by addressing the OSD color buffer register, COLBUF (FCH, set 1, bank 1). The color selection bits are COLBUF.2, COLBUF.1, COLBUF.0 and COLBUF.3 (H/T and BGRND). These four bits comprise the RGB value (bit 10, 11, 12) and H/T and BGRND enable bit (bit 13) of the character data stored in the video RAM.

When programming the display RAM values for a character display, you must first load a 3-bit color value into the color buffer. This color setting is automatically appended to each 10-bit character code as it is written to the OSD RAM addresses. If only one COLBUF value is loaded, all characters in the screen display will, of course, be the same color. To change the display color of successive characters, modify the COLBUF value *before* you load the address data for a specific row and column into the video RAM.

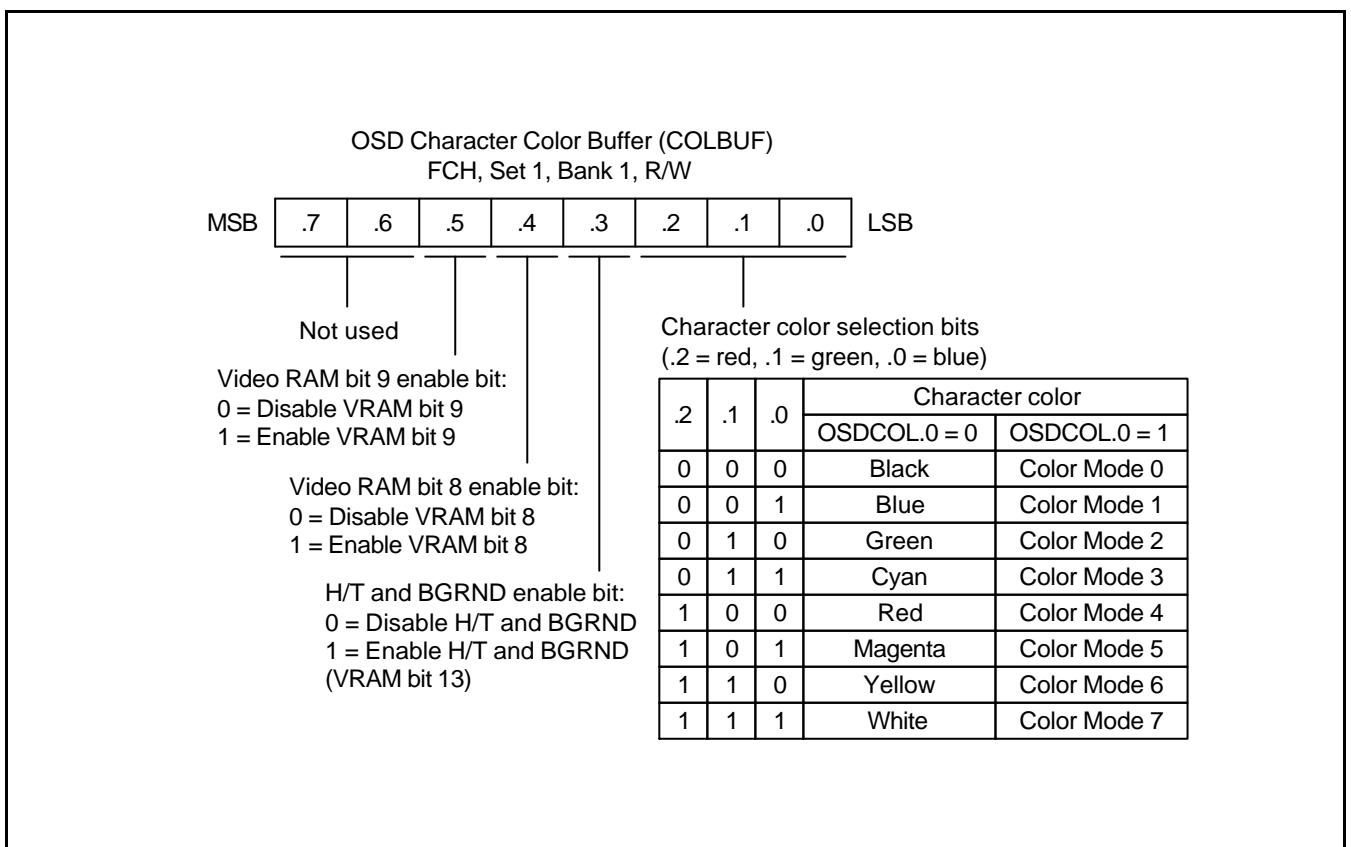


Figure 13-15. OSD Character Color Buffer Register (COLBUF)

BACKGROUND COLOR CONTROL

The background color control register, COLCON, lets you select background colors for both the display frame and characters:

- *Frame background* is the full-screen display field upon which the character display is imposed.
- *Character background* is a color field that surrounds the individual character. To enhance readability, the background is usually a color that contrasts or highlights the characters in a pleasing manner.

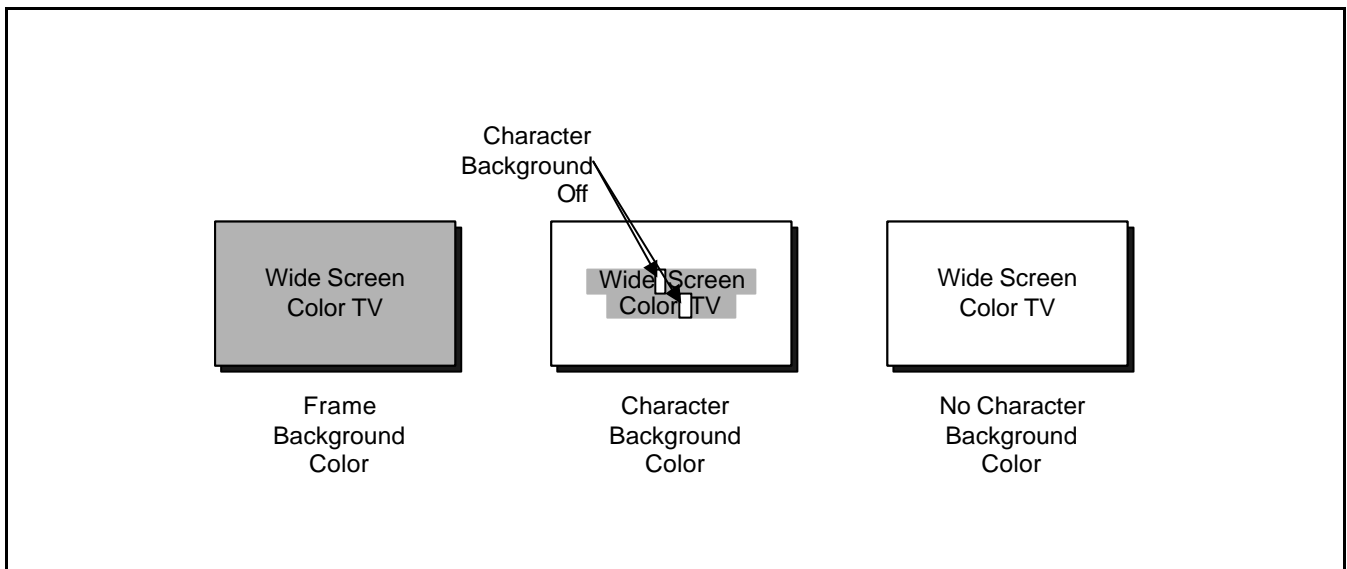


Figure 13-16. Background Color Display Conventions

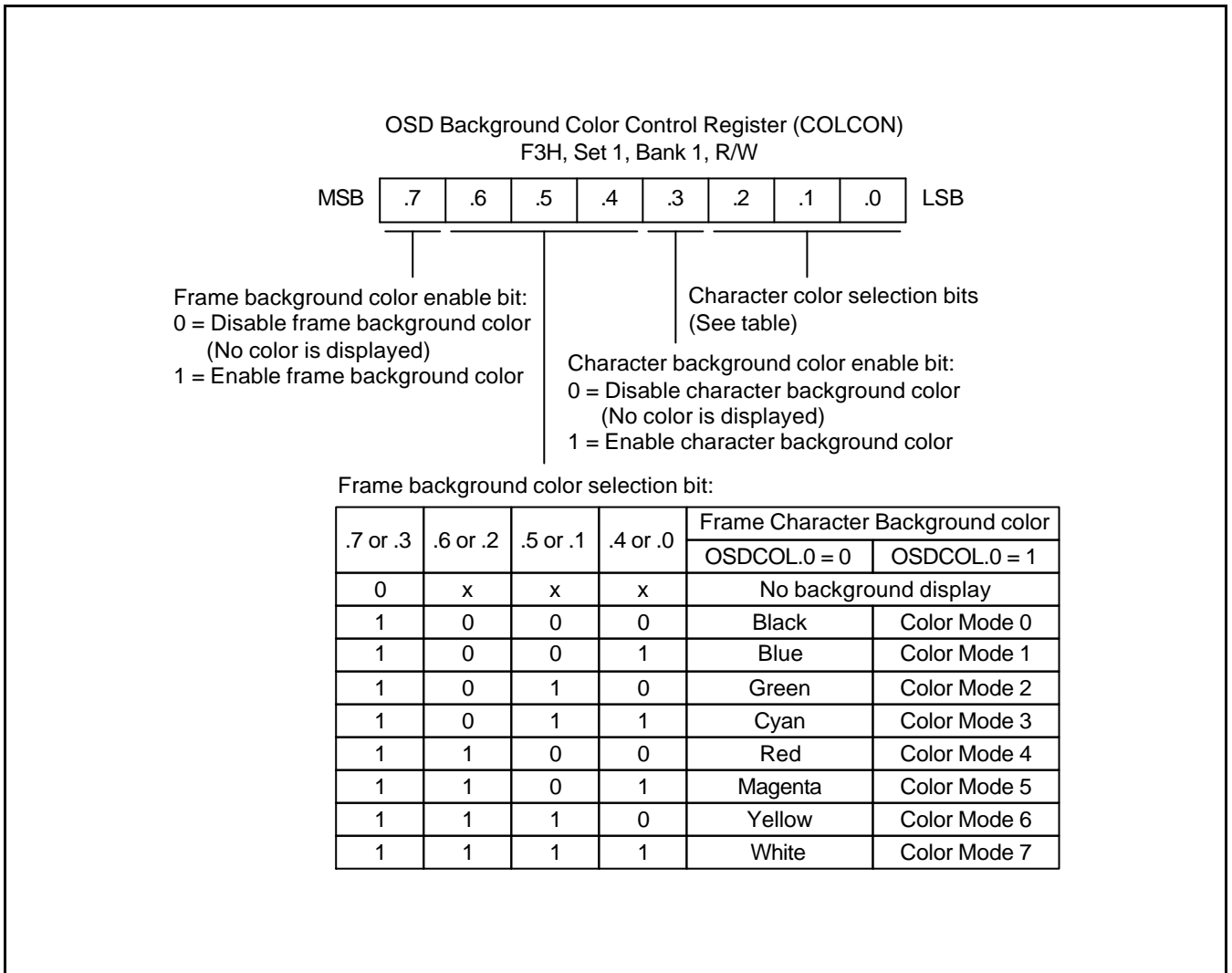


Figure 13-17. OSD Background Color Control Register (COLCON)

V-SYNC BLANK CONTROL REGISTER (VSBCON)

VSBCON sets the blank area, which stops the L-C oscillator during the defined time from the V-sync input time. Unit of V-sync blank time is 1 H-sync. It can be set up to a maximum of 31 H-syncs. If VSBCON.4 is set from "0" to "1001B", blank time is always 9 H-syncs regardless of the setting value.

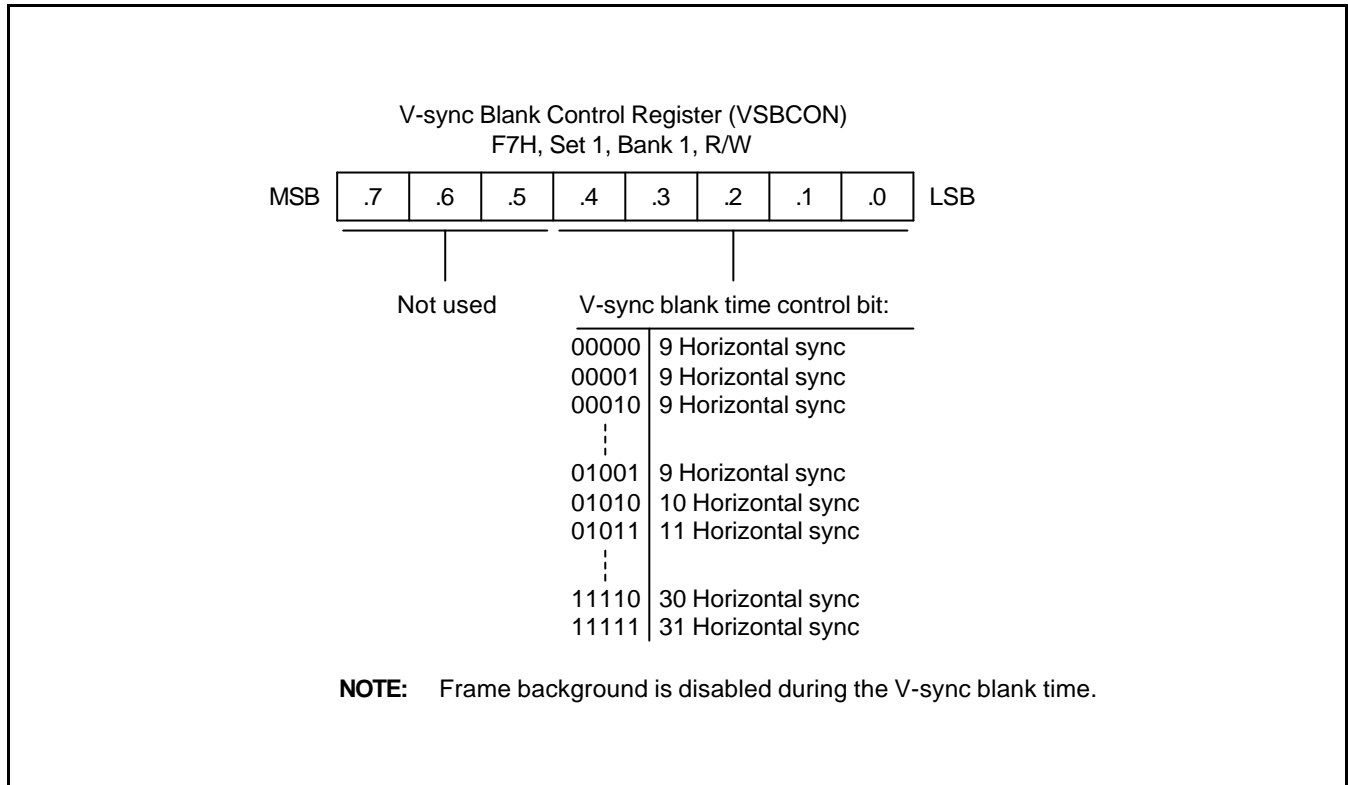


Figure 13-18. V-sync Blank Control Register (VSBCON)

V-SYNC BLANK AND TOP MARGIN TIMING DIAGRAM

The following is a timing diagram simplified with external V-sync input and H-sync input signals. V-sync blank and top margin are controlled by VSBCON and ROWCON. VSBCON .4-.0 = 01011B (V-sync blank time = 11 Horizontal sync). ROWCON.7-.3 = 00100B (top margin control value = 16, top margin = 5).

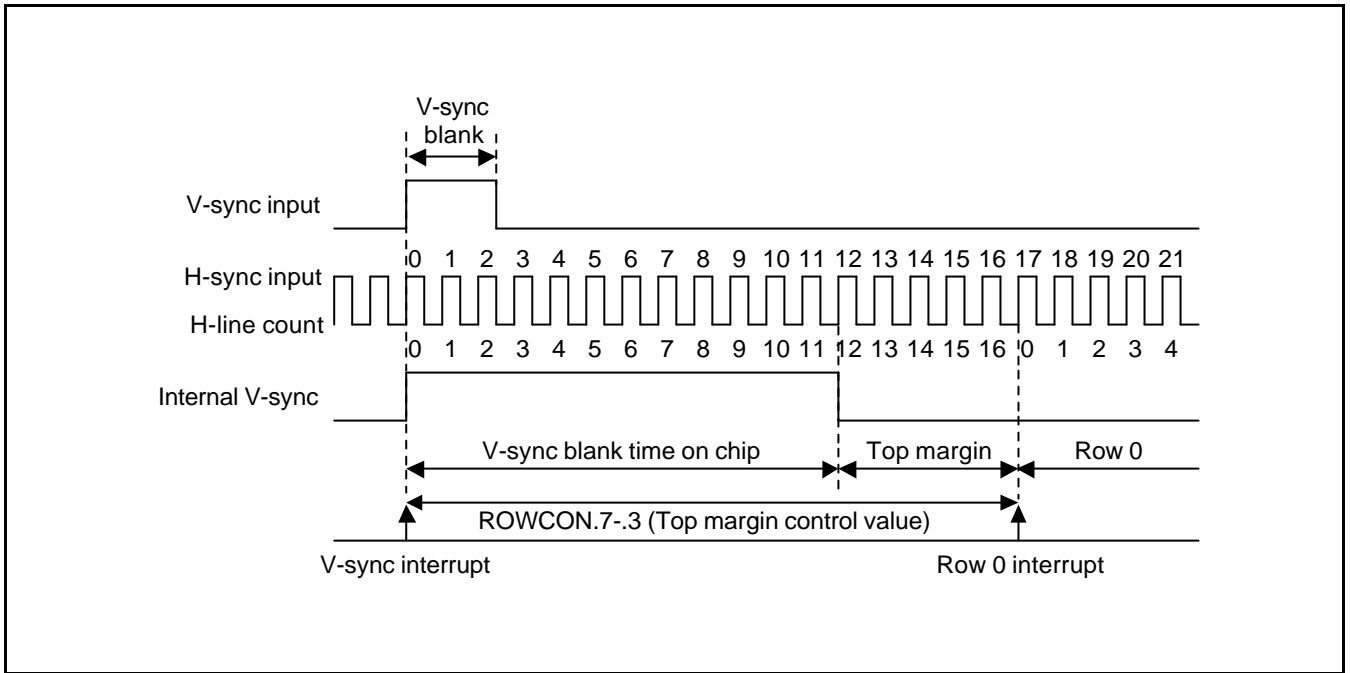


Figure 13-19. V-sync Blank and Top Margin Timing Diagram

HALFTONE SIGNAL CONTROL REGISTER (HTCON)

The halftone function lets you output halftone control signals to peripherals such as a chroma-IC. You can select halftone output for character back ground periods (as selected by bit 13 in the video RAM) or for frame periods (regardless of the bit 13 setting). The halftone signal control register, HTCON, has the following functions:

- Halftone option selection (character or frame)
- Halftone display enable/disable
- V-sync interrupt enable and pending control
- Polarity selection of RGB and halftone outputs

Bits 4 and 5 are used for OSD Row interrupt function.

OSD ROW Interrupt Control

The S3C880A/F880A has a total of 12 OSD display rows. When enabled, an OSD ROW interrupt occurs in the first line of each row. Up to 12 OSD ROW interrupts can be generated, while this number can be reduced according to different settings in top margin (ROWCON.7–.3), inter row space (ROWCON.2–.0), vertical character size (CHACON.7–.6), and Vsync blank time (VSBCON). The ROW counter of DSPCON.7–.4 informs the order of an OSD ROW interrupt occurring within a frame. An OSD ROW interrupt is generated at the beginning of a ROW (for ROW0 through ROW11).

OSD ROW interrupt allow different controls to each ROW. If the OSD control register is adjusted in the N-th row area, the new value is applied from (N+1)th row. That is, if the OSD control register is adjusted in the first OSD ROW interrupt (DSPCON.7–.4 = 0000B) service routine, the new value is applied from ROW1. A change in the 12 th OSD ROW interrupt service routine affects the rows from ROW0.

NOTE: OSD output enable/disable (DSPCON.0) settings are immediately applied. Top margin (ROWCON.7–.3) and VSBCON are applied in accordance with Vsync input signals.

Halftone Option Selection

In character periods only (HTCON.2 = "0"), the character specified in COLBUF.3 may have the halftone function according to the condition of DSPCON.2–.1 (DSPCON.2–.1 = "10" or DSPCON.2–.1 = "11").

In all frame periods (HTCON.2 = "1"), the entire section can have the function, regardless of the COLBUF.3 condition.

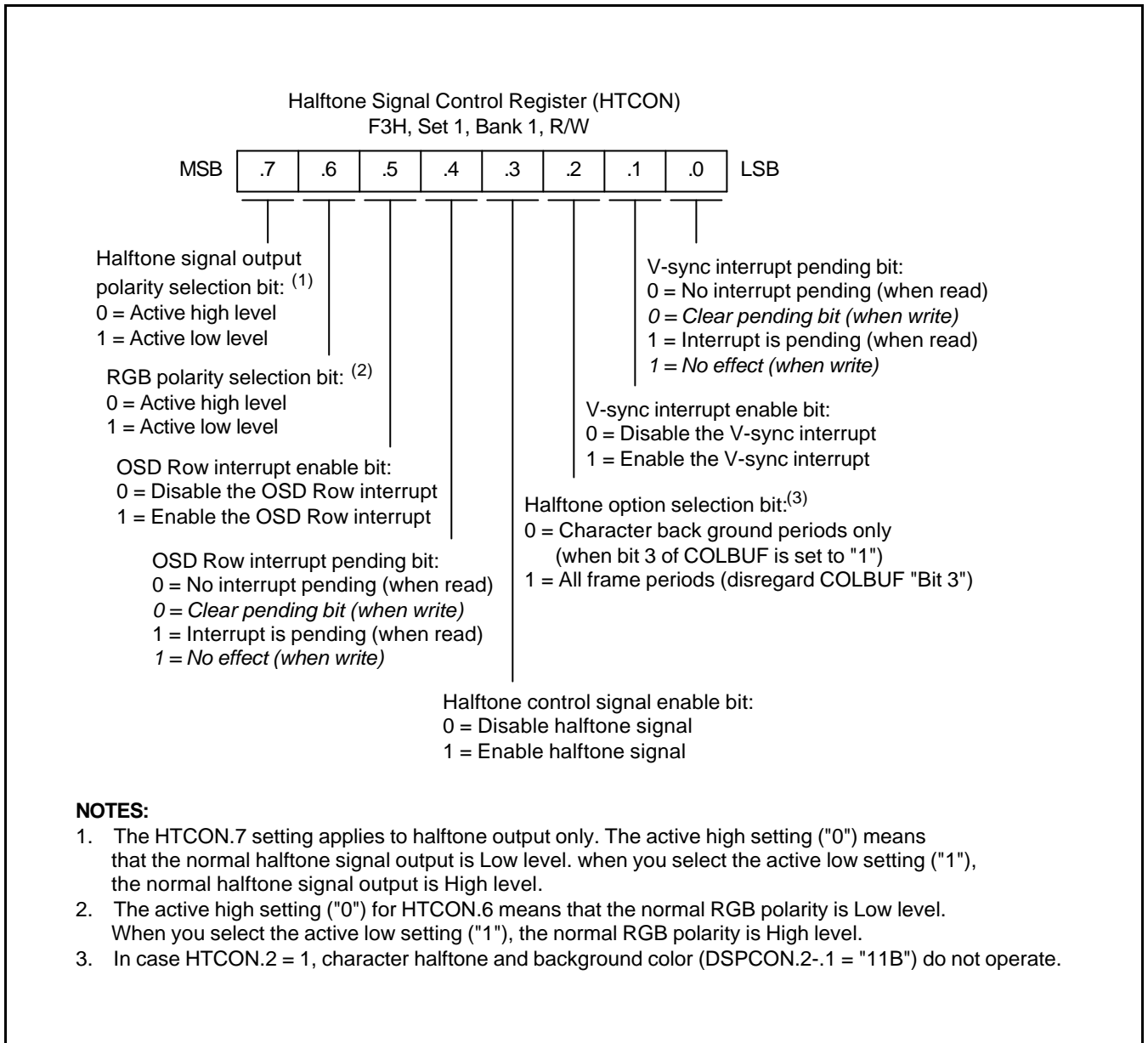


Figure 13-20. HalfTone Signal Control Register (HTCON)

Background Color and Halftone Function Mode

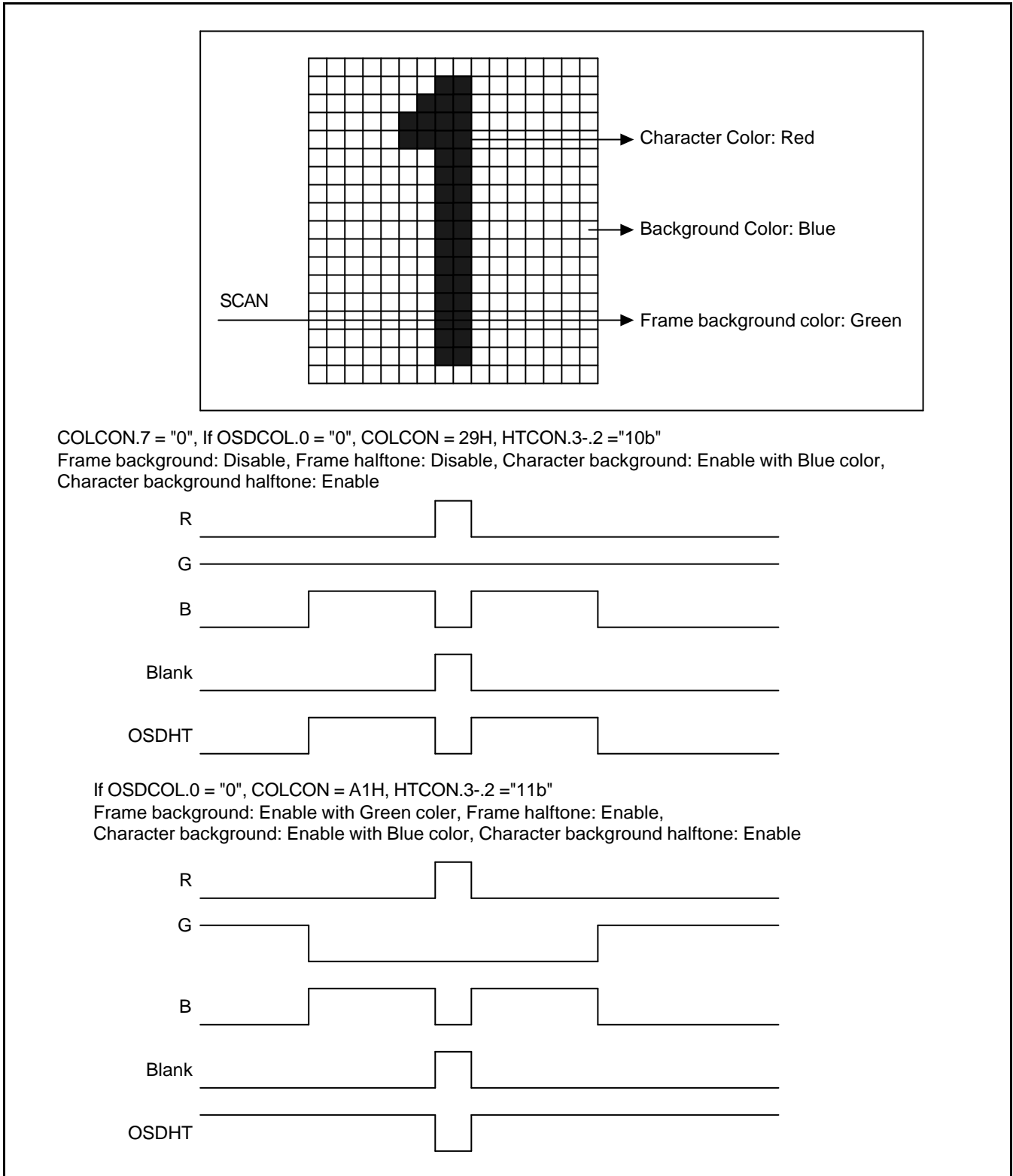


Figure 13-21. Halftone or Character Background Signal Output

OSD FIELD CONTROL REGISTER (OSDFLD)

OSD field control register helps recognizing whether the current field is an EVEN field or an ODD one, in a TV signal frame. This control register must be defined for a current field recognition of V-sync and H-sync entering the S3C880A/F880A. In order to recognize an even field, OSDFLD.0–3 defines the range starting from the point of V-sync edge, where H-sync must be present. If H-sync exits within the range, the field is recognized as an EVEN field.

OSDFLD.4 defines when H-sync must be detected. If it is set to “0”, the existence of H-sync is detected within the range set by OSDFLD.0–3 before V-sync is input. If it is set “1”, it is detected after V-sync is input.

OSDFLD.5 describes whether the current, field input by the field control which is set by OSDFLD.0–3 and OSDFLD.4 is an EVEN field or an ODD one.

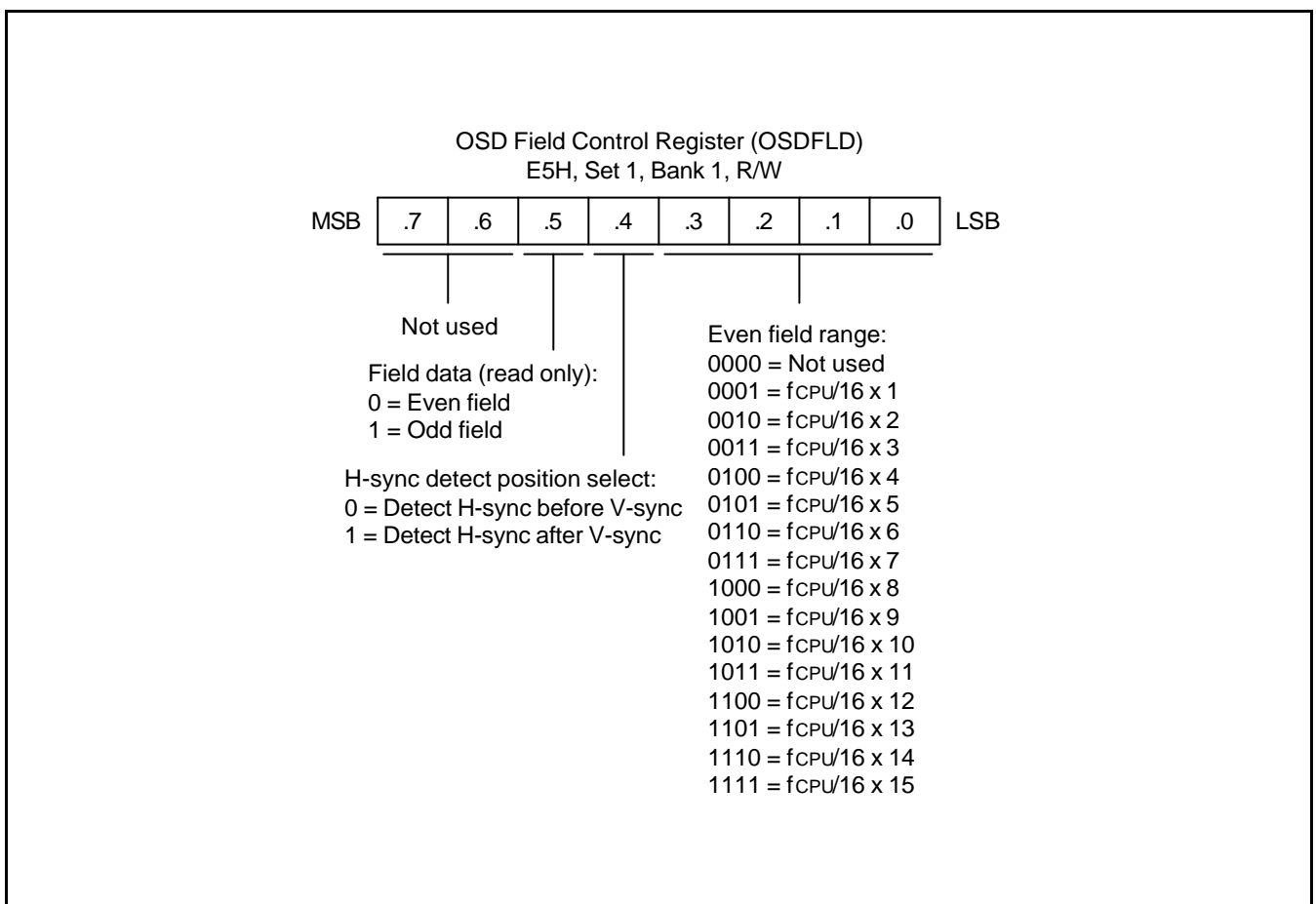


Figure 13-22. OSD Field Control Register (OSDFLD)

Field Detect by OSDFLD Control

When control register set is OSDFLD.0-.3 = "1010B", OSDFLD.4 = 0

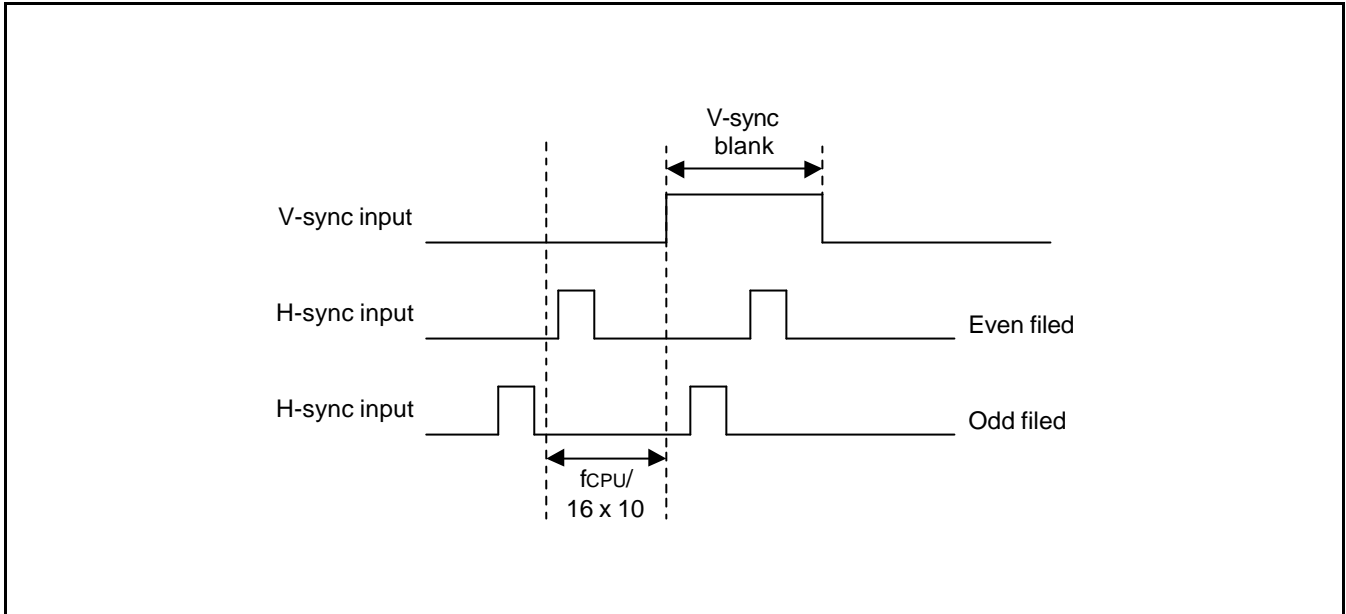


Figure 13-23. Field Detect in Before V-sync

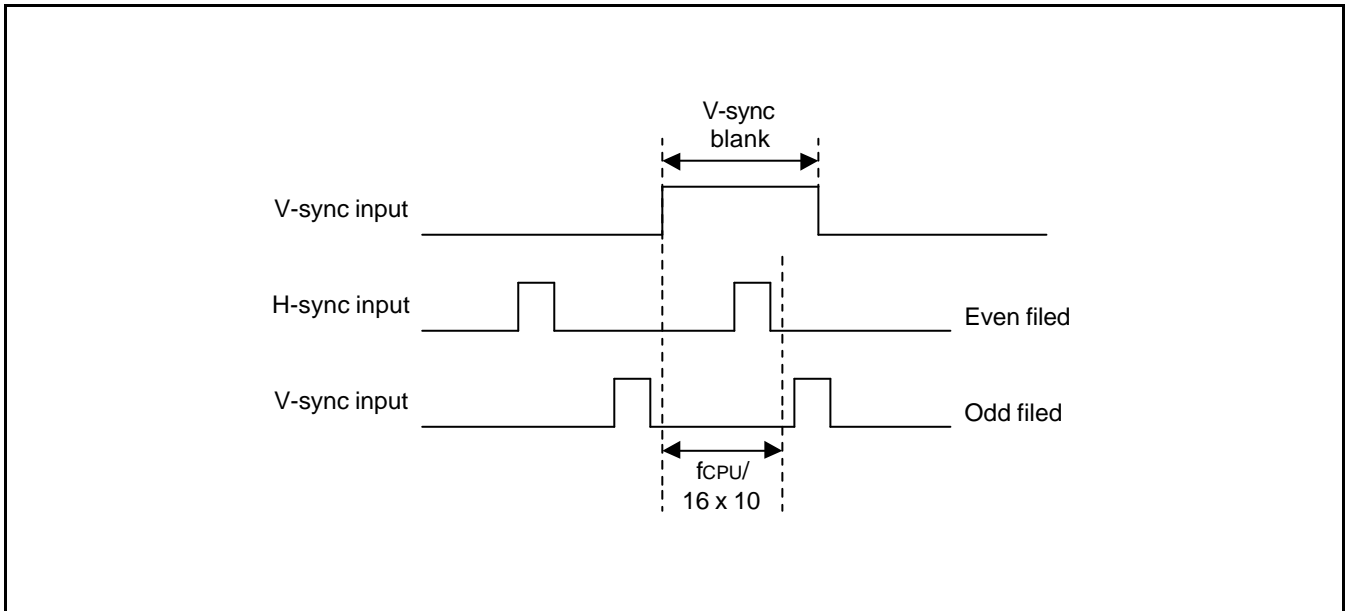


Figure 13-24. Field Detect in After V-sync

OSD PALETTE COLOR CONTROL

OSD Palette Color Mode Registers (OSDPLTR, OSDPLTG, OSDPLTB)

OSD palette color mode register R, G, B controls the color of OSD R, G, B output. OSDPLTR1, OSDPLTR2, OSDPLTG1, OSDPLTG2, OSDPLTB1, and OSDPLTB2 are composed of 8 bits each, in which the combinations of bit0-bit1, bit2-bit3, bit4-bit5, bit6-bit7 of OSDPLTx1 (x = R, G, B) define color mode 0 to 3 and bit0-bit1, bit2-bit3, bit4-bit5, bit6-bit7 of OSDPLTx2 (x = R, G, B) define color mode 4 to 7, respectively.

Each color mode can express upto 64 color by combing the six registers (OSDPLTR1, OSDPLTR2, OSDPLTG1, OSDPLTG2, OSDPLTB1, OSDPLTB2). As one color mode can select one color out of 64 choices, and there are 8 color modes, a total of 8 colors can be displayed at time. For example, when combining color mode 0, each of OSDPLTR1.0-1, and OSDPLTB1.0-1 can produce 4 kids of red level, which can be multiplied upto 64 combinations.

Each 2 bits define a color mode make 4 color levels available. When the standard lighting is 100%, the value "00B" means disabled, "01B" means 33% and "10B" means 66% of the standard light level.

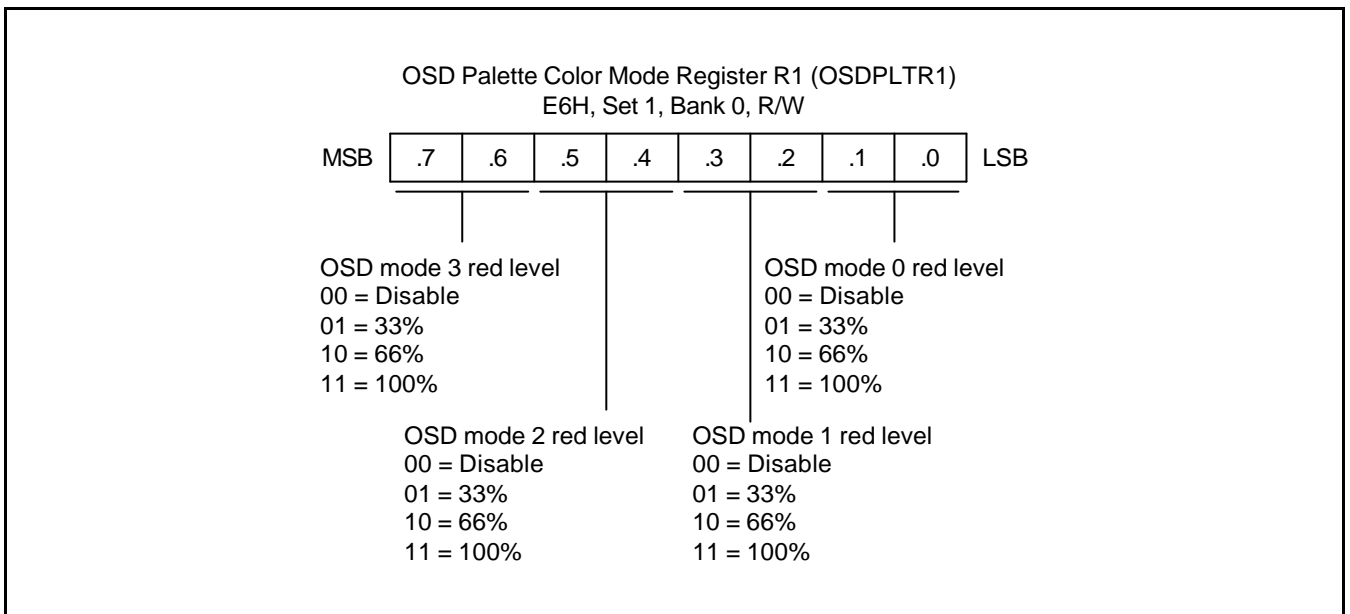


Figure 13-25. OSD Palette Color Mode Register R1 (OSDPLTR1)

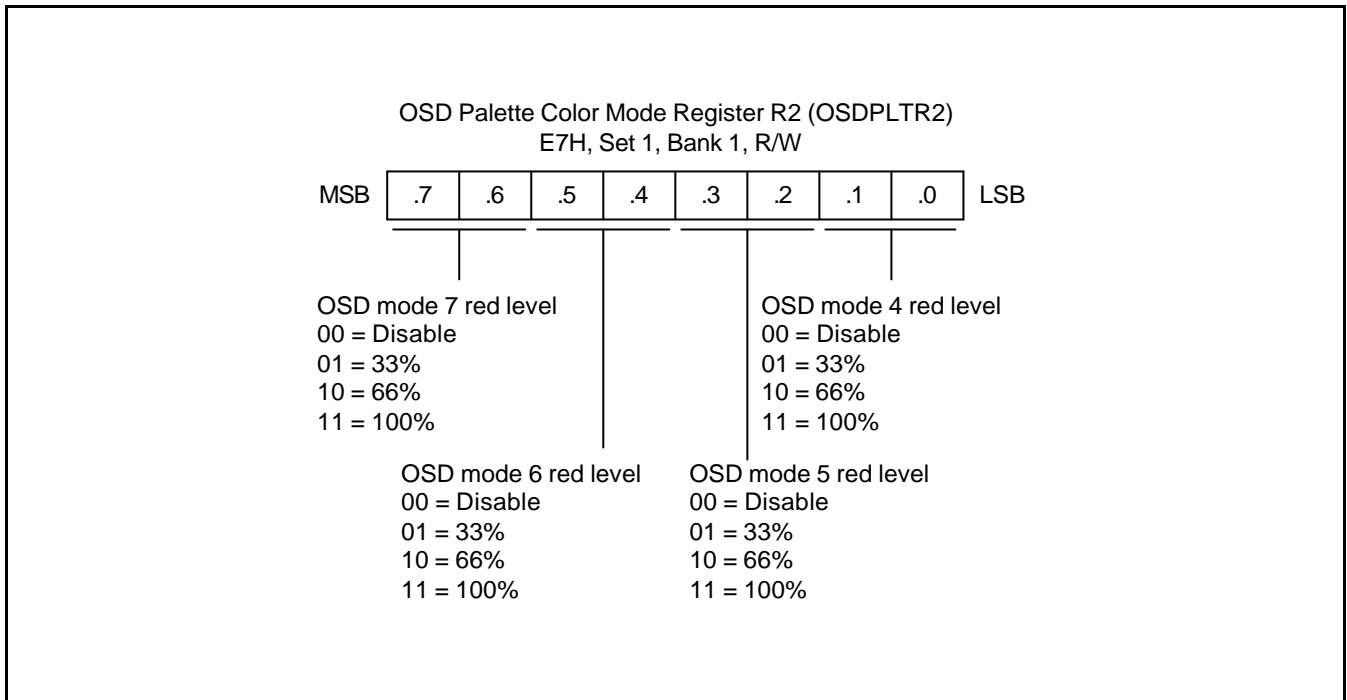


Figure 13-26. OSD Palette Color Mode Register R2 (OSDPLTR2)

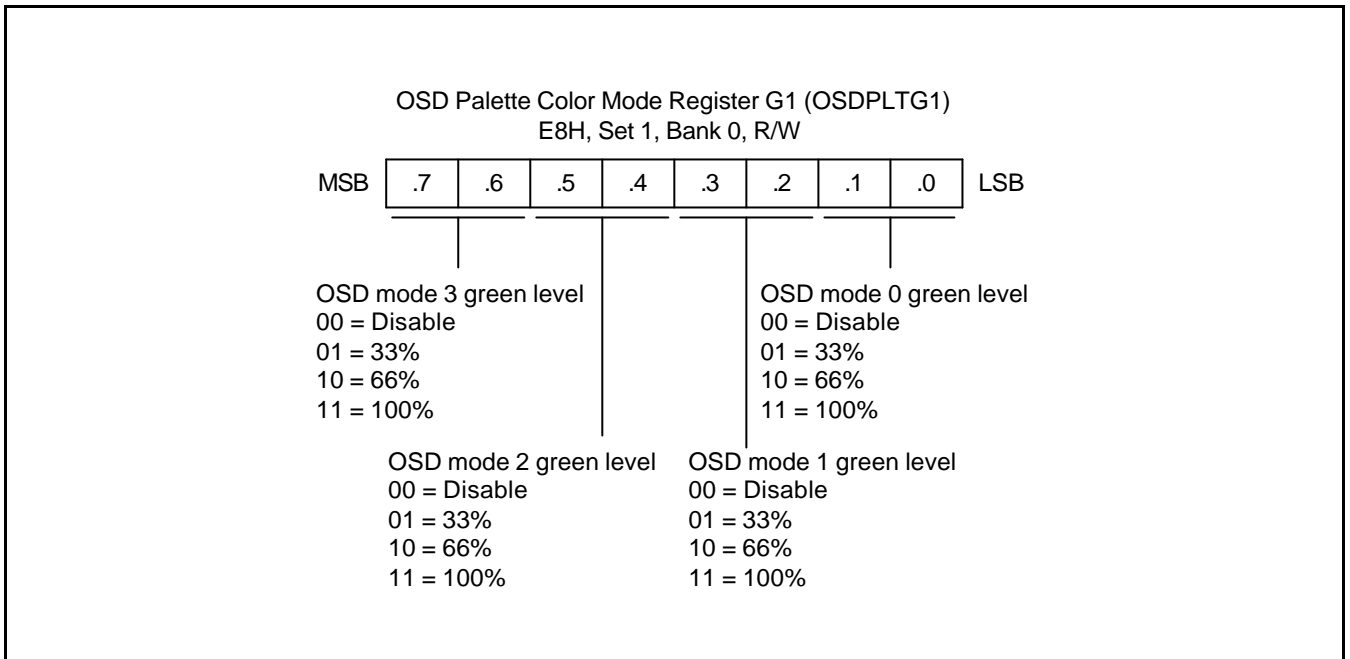


Figure 13-27. OSD Palette Color Mode Register G1 (OSDPLTG1)

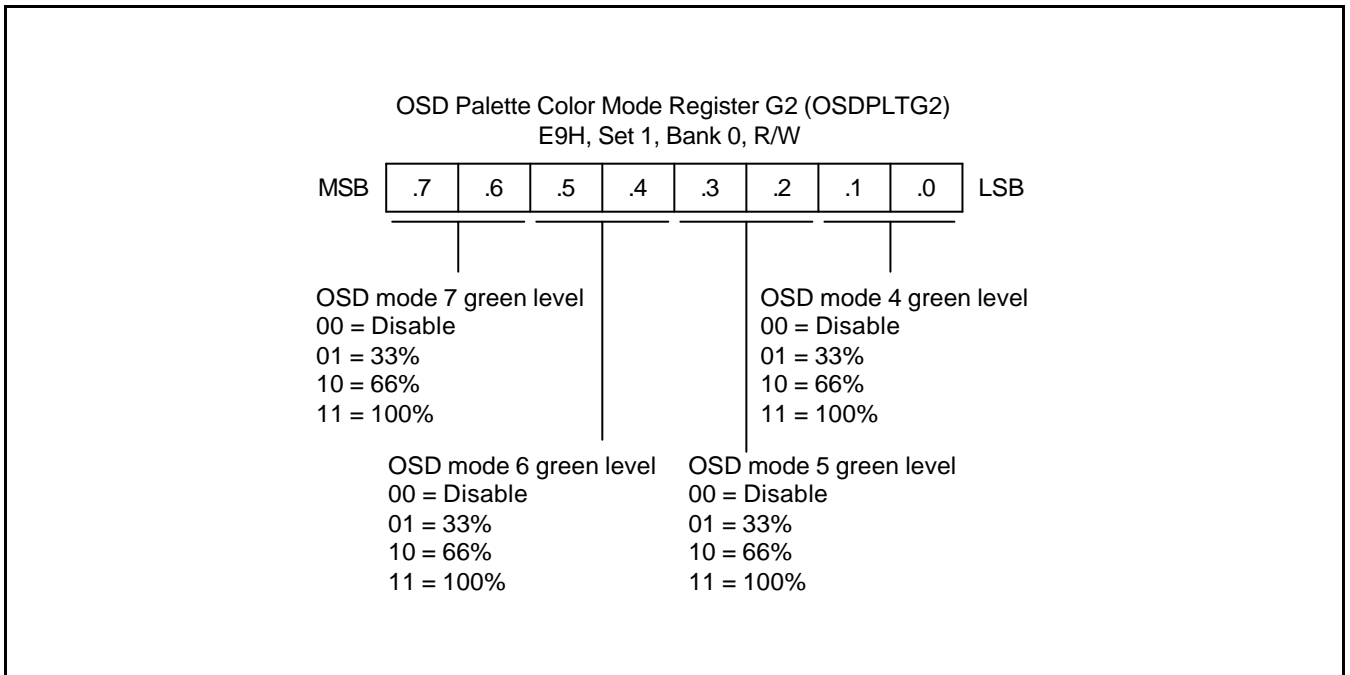


Figure 13-28. OSD Palette Color Mode Register G2 (OSDPLTG2)

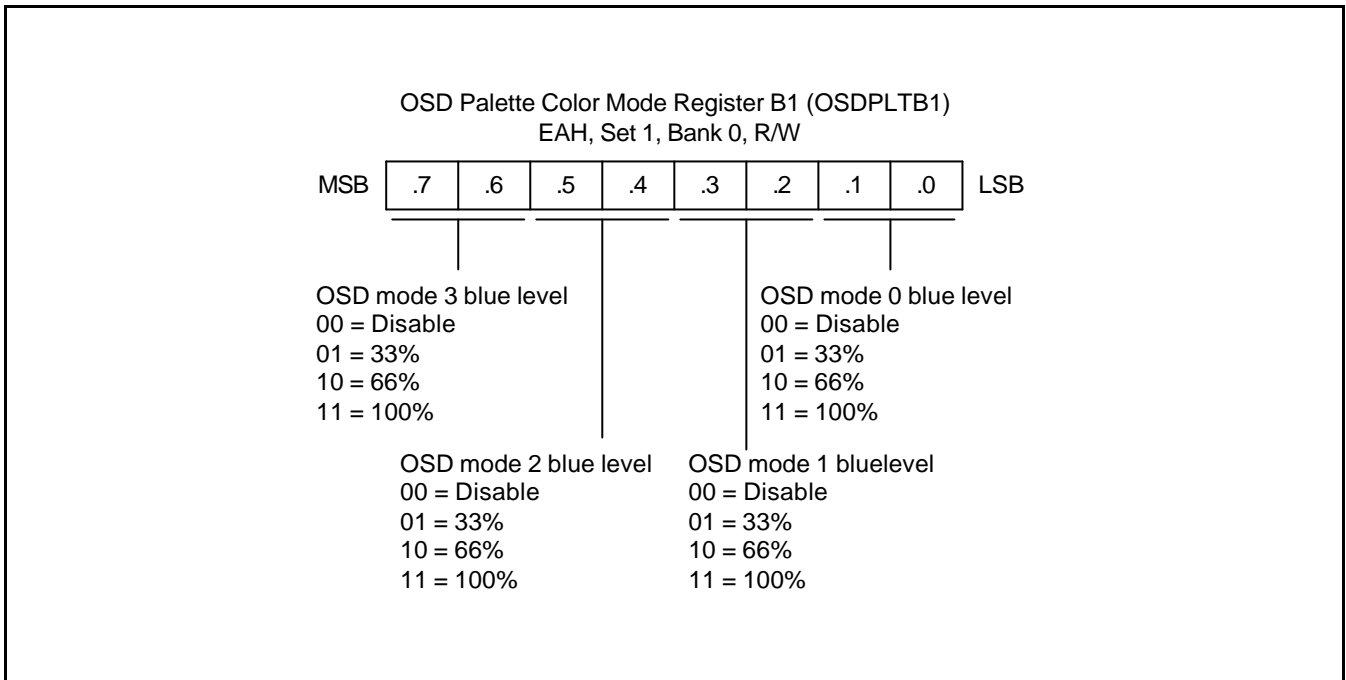


Figure 13-29. OSD Palette Color Mode Register B1 (OSDPLTB1)

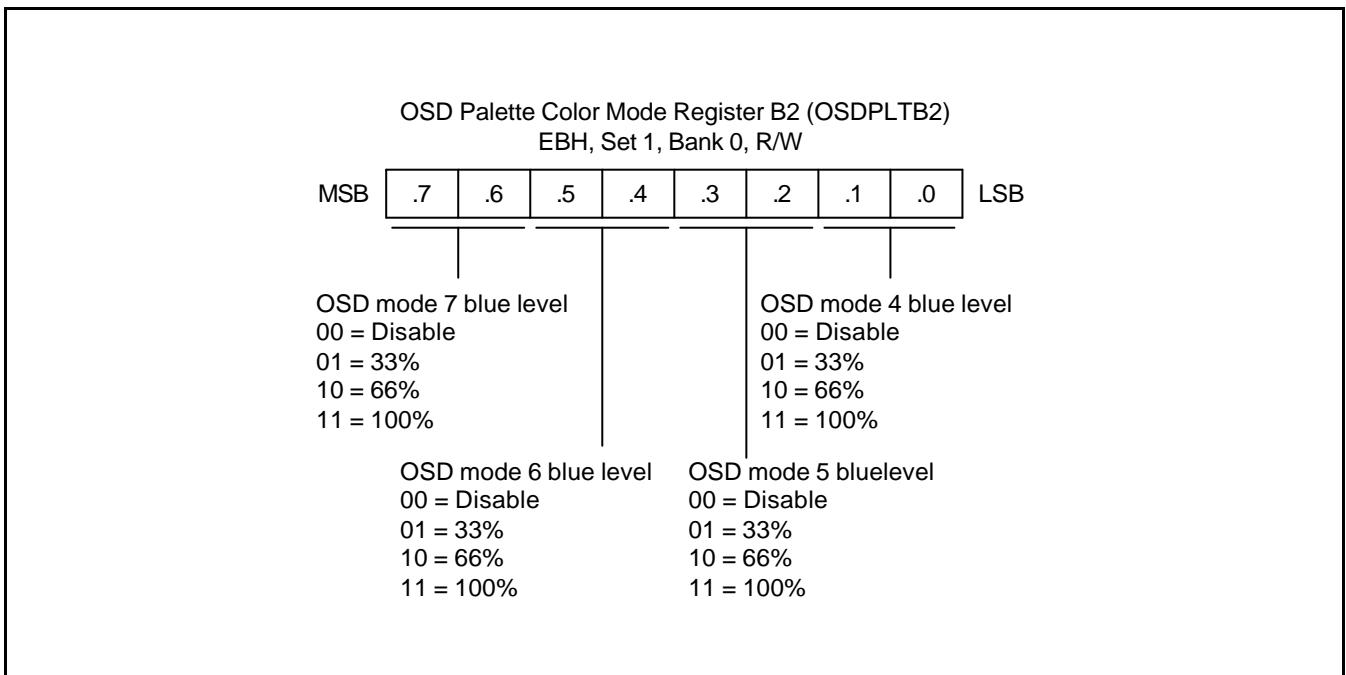


Figure 13-30. OSD Palette Color Mode Register B2 (OSDPLTB2)

OSD SPACE COLOR CONTROL REGISTER (OSDCOL)

RGB output selection

S3C880A/F880A has two RGB output mode: digital mode and analog mode.

In Digital mode, OSDCOL.0 must be set to 0. RGB output has two levels, VSS and VDD. Eight colors can be produced: black, blue, green, cyan, red, magenta, yellow and white. OSD palette color control registers, OSDPLTR1, OSDPLTR2, OSDPLTG1, OSDPLTG2, OSDPLTB1, and OSDPLTB2, are not used in this mode.

In analog mode, OSDCOL.0 must be set to 1. R.G.B output color bright can be selected among four levels respectively. 64 colors can be selected by setting OSD palette color control registers, OSDPLTR1, OSDPLTR2, OSDPLTG1, OSDPLTG2, OSDPLTB1, and OSDPLTB2. In one display row you can select 8 colors, color mode 0–7, by setting COLBUF.2–0. The color selected by color mode 0–7 can be changed in every display row.

Inter-row space halftone

Inter-row spacing is the distance (in H-sync pulses) between two rows of displayed characters and can be changed by setting ROWCON.2-0. Also halftone character can be changed for this inter-row spacing.

For OSDCOL.1=0, halftone function of inter-row space region is the same as that of the character background region. That is, if the halftone function of character background region is enabled by setting HTCON.3 to "1", the halftone function of inter-row space region is enabled. When HTCON.3 is set to "1", halftone function of character background is enabled regardless of the value of HTCON.2.

For OSDCOL.1=1 (depend on frame background halftone), inter-row space halftone function is enabled when the value of HTCON.3 and HTCON.2 are set to "1".

Inter-row space color

Inter-row space color depends on the character background color and frame background color by COLCON. When OSDCOL.2 is "0", inter-row space color depends on the current character background color; when OSDCOL.2 is "1", inter-row space color depends on the current frame background color.

Fringe dot size selection

1 dot (when OSDCOL.3 is "0") is a fringe size, which is set by OSDFRG1 and OSDFRG2.

For 1/2 dot fringe size (when OSDCOL.3 is "1"), fringe function is set by 1/2 dot unit. In the interlaced scan, even field line and odd field line are added to form 1 dot of length. If character size of length is x1 or x3 in the 1/2 dot fringe size, blinking can occur. So, 1 dot fringe size method is recommended.

Inter character smoothing control

If inter character smoothing is enabled (when OSDCOL.4 is "1"), adjacent character is considered as one character and smoothing function is enabled.

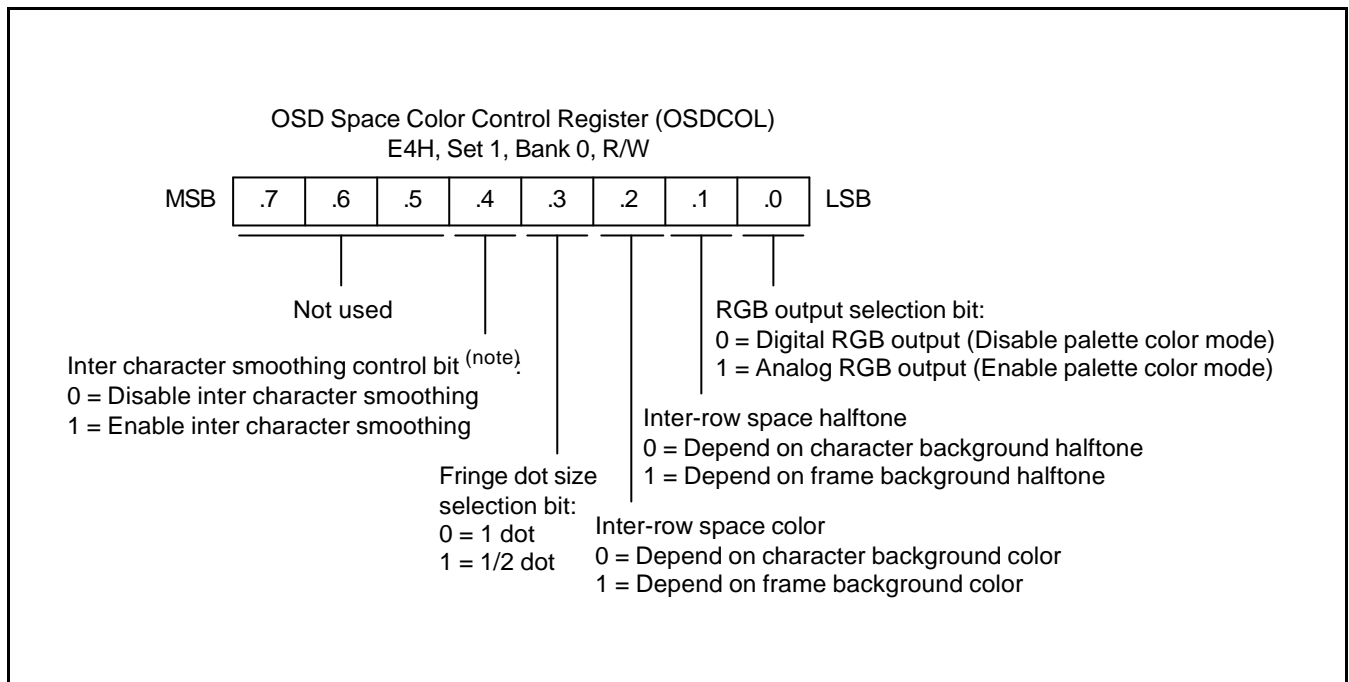


Figure 13-31. OSD Space Color Control Register (OSDCOL)

OSD BORDER/FRINGE FUNCTION

Fringing Function

The fringing function is used to display a character with a fringe (fringe means shadowed character at bottom and right direction) width is 1 or 1/2 dot in a different color from that of the character. For all character size, fringe width is 1 or 1/2 dot by set of OSDCOL.3. When a character is displayed with the maximum of 18 vertical dots and 16 horizontal dots, the fringe exceeds right and bottom of the character display area. The exceeded fringe can be displayed; however, display characters have higher priority to fringe. In this case, If you want to display both fringe and character, you should set inter-row space and inter-column space. When 1dot fringe function is selected, you should set minimum two dots of inter-row space or inter-column space. When 1/2 dot fringe function is selected, you should set minimum one dot of inter-row space or inter-column space.

Fringing is enabled for each line by setting each bit of OSDFRG1 and OSDFRG2 to "1" when OSDFRG2.7="1".

Three bits of OSDFRG2.6-.4 are control Border color. A color for fringe is specified common to selected row and a color for fringe to each row are controlled differently.

NOTE: When Vertical size x1 and x3 in 1/2 fringe enabled, the flickering may be generated. Because vertical 1 dot means even and odd field, that is 1/2 dot is even or odd field area. So interlace scan TV system, you can see the flickering.

Border Function

The Border function is used to display a character with a Border (Border means shadowed at all character boundary) width is 1/2 dot in a different color from that of the character. For all character size, Border width is 1/2 dot. When a character is displayed with the maximum of 18 vertical dots and 16 horizontal dots, the fringe exceeds right and bottom of the character display area. The exceeded Border can be displayed; however, display characters have higher priority to fringe. In this case, If you want to display both Border and character, you should set inter-row space and inter-column space over minimum one dot. Border is enabled for each line by setting each bit of OSDFRG1 and OSDFRG2 to "1" when OSDFRG2.7="0".

Three bits of OSDFRG2.6-.4 are control Border color. A color for Border is specified common to selected row and a color for fringe to each row are controlled differently.

NOTE: When Vertical size x1 and x3, the flickering may be generated. Because vertical 1 dot means even and odd field, that is 1/2 dot is even or odd field area. So interlace scan TV system, you can see the flickering.

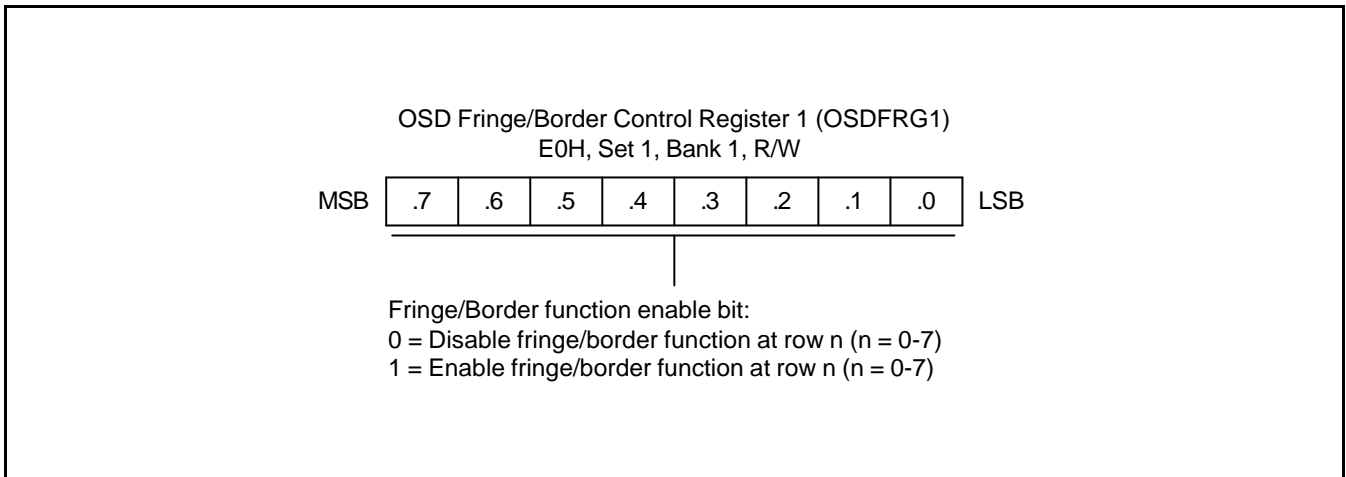


Figure 13-32. OSD Fringe/Border Control Register 1 (OSDFRG1)

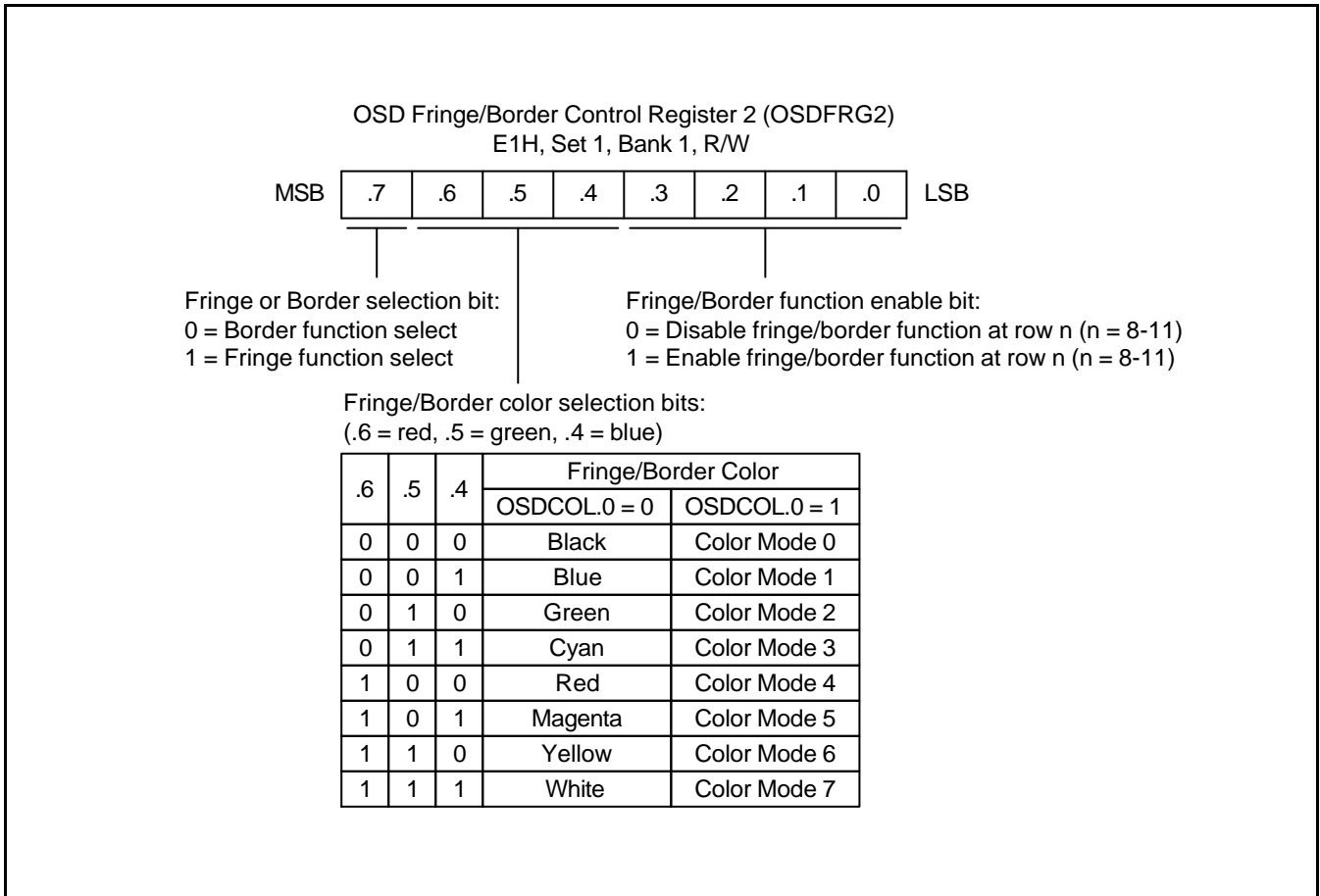


Figure 13-33. OSD Fringe/Border Control Register 2 (OSDFRG2)

OSD SMOOTH FUCNTION

Smoothing function

The smoothing function is used to make characters look smooth. Enabling smoothing displays 1/4 dot between two dots connecting corner to corner within a character. Smoothing is enabled by setting each bit of OSDSMH1 and OSDSMH2 to "1". A smooth is specified common to selected row.

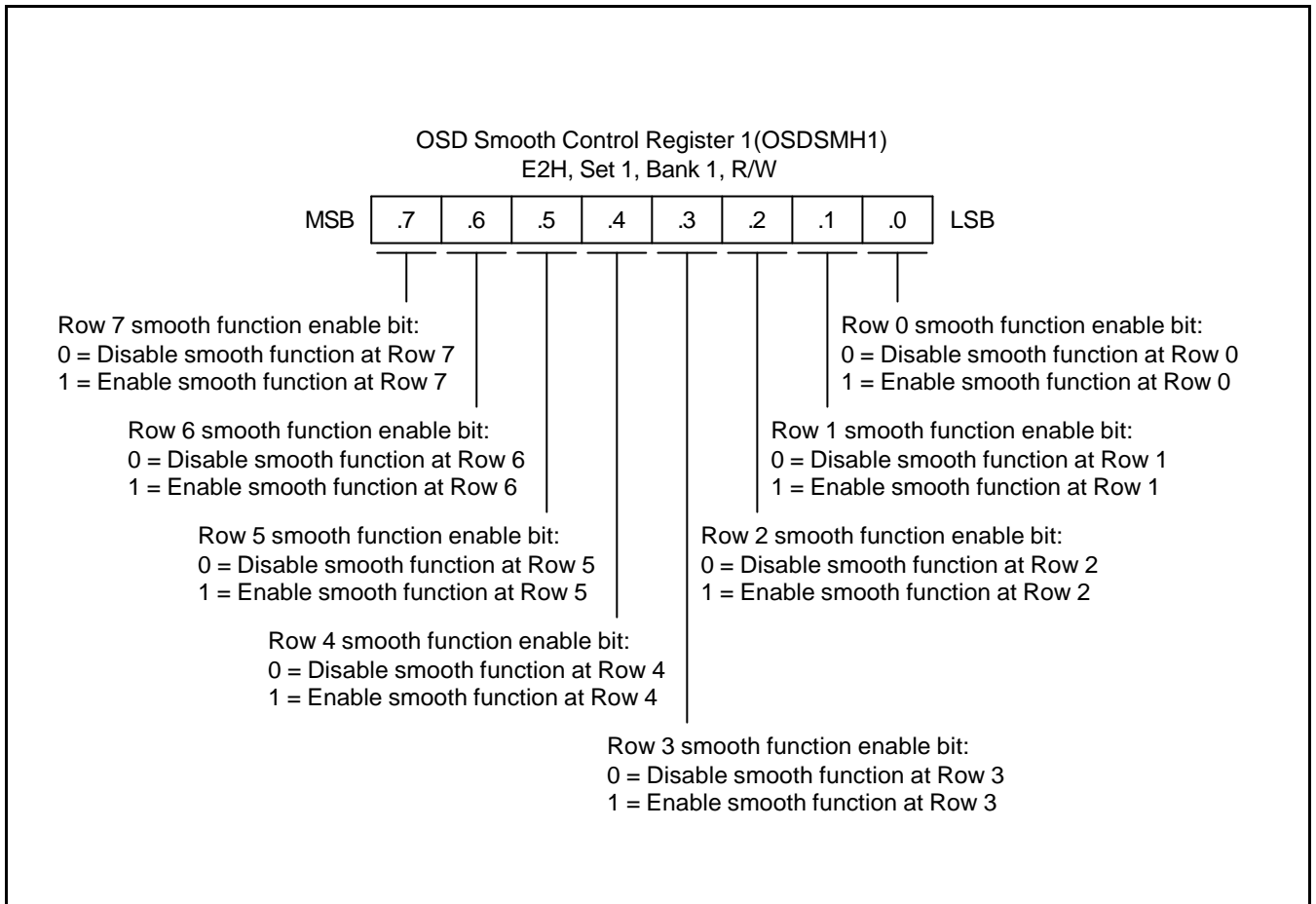


Figure 13-34. OSD Smooth Control Register 1 (OSDSMH1)

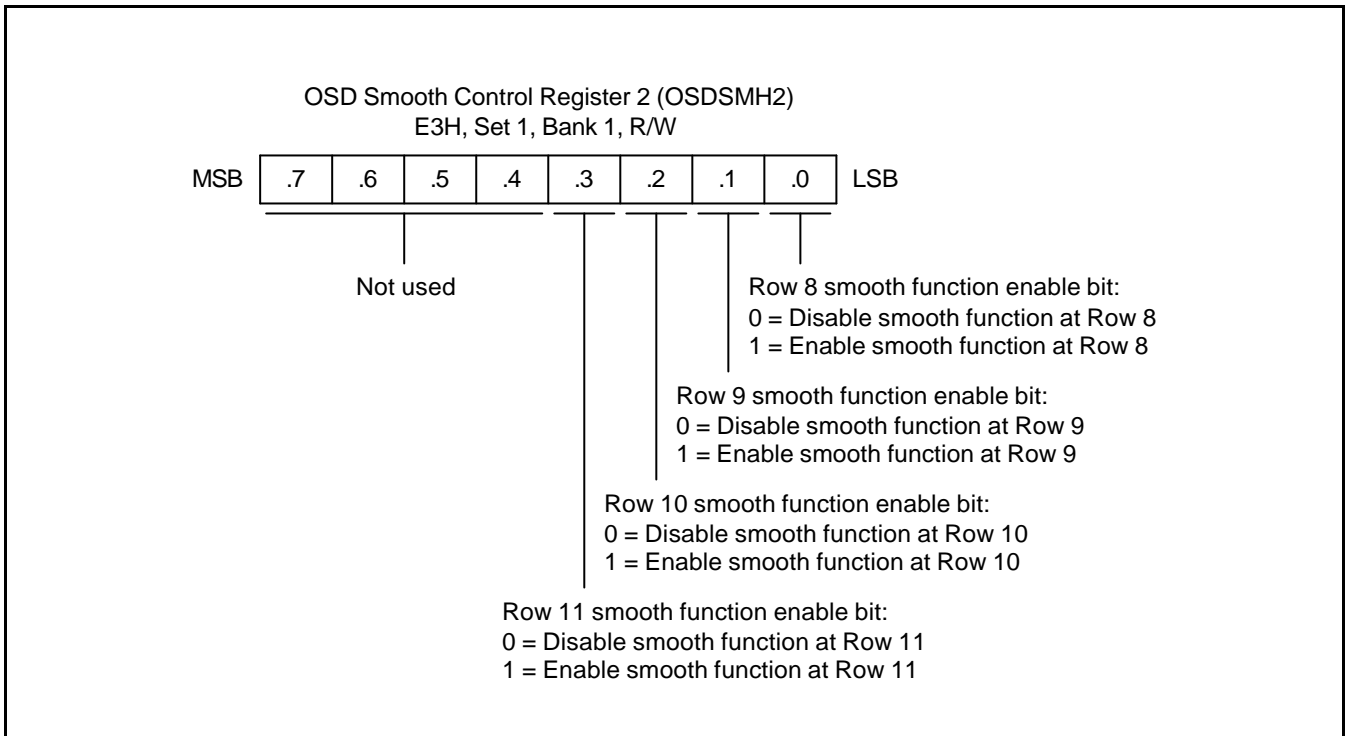


Figure 13-35. OSD Smooth Control Register 2 (OSDSMH2)

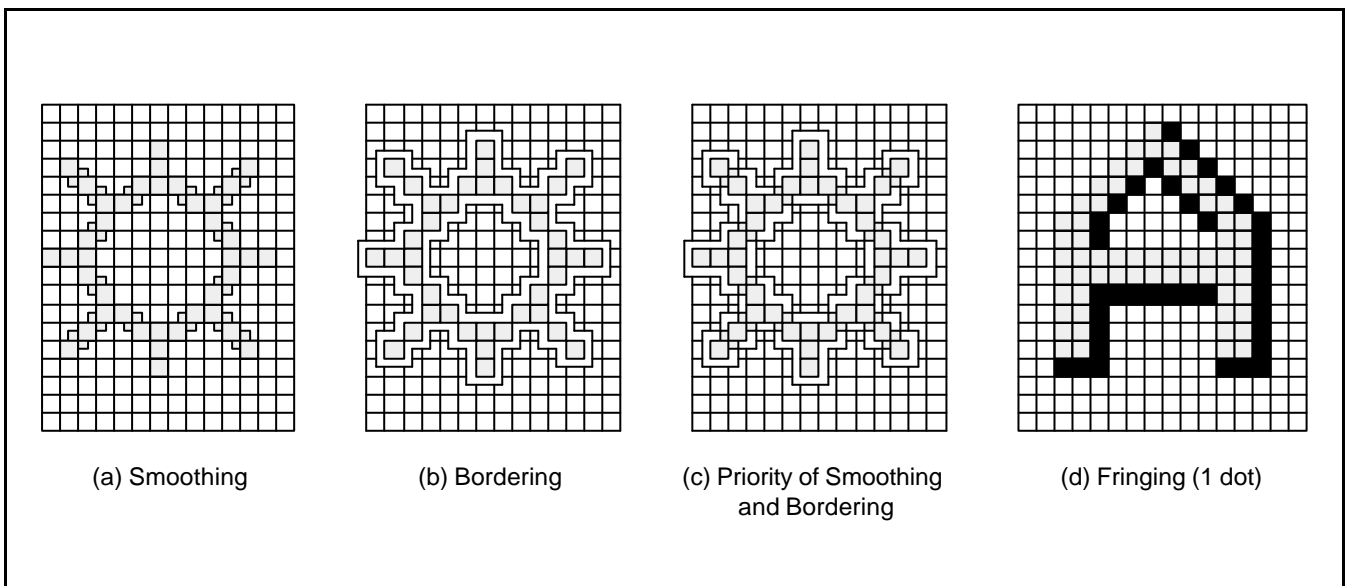


Figure 13-36. Smoothing/Fringing/Priority of Smoothing and Fringing

PROGRAMMING TIP — Row Interrupt Function

This example shows the effect of the control register setting excluding the HTCON.5,4,1,0 and DSPCON 3,0 occurs in the next row. The sample program should meet the following specifications:

1. The character size of the row 2 must be double-sized (× 2).
2. The character size of the other rows must be normal (× 1).

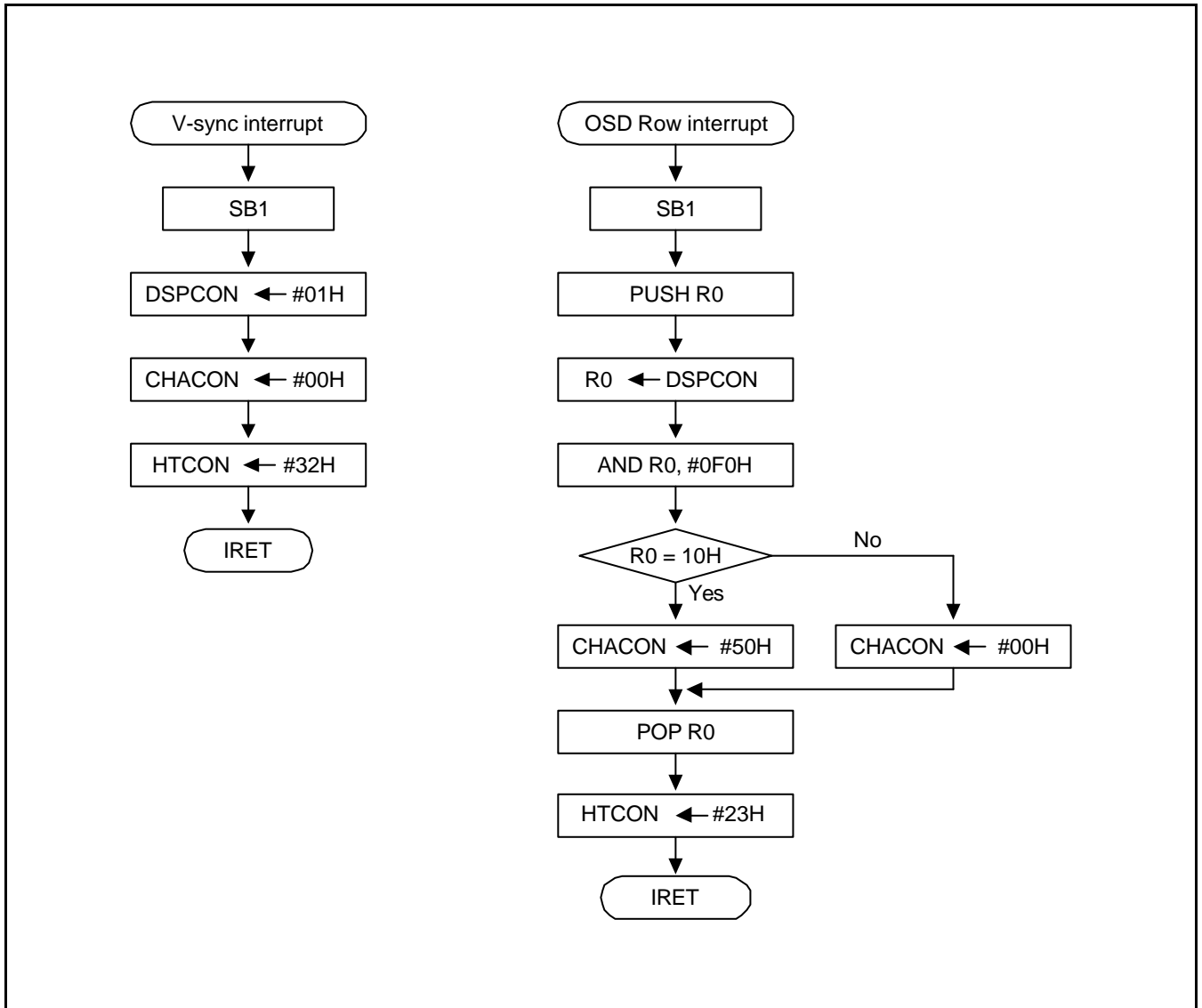


Figure 13-37. Decision Flowchart for Row Interrupt Function Programming Tip

 **PROGRAMMING TIP — Row Interrupt Function (Continued)**

Vsync_int:

```

    SB1                ; Select bank 1
    LD      DSPCON,#01H ; OSD on, H/V sync rising edge

```

;This is Vsync interrupt service routine.

Interrupt_end:

```

    LD      HTCON, #32H ; Pending bit clear
    IRET

```

Row_int:

```

    SB1                ; Select bank 1
    PUSH   R0          ; Stack ← R0
    LD      R0,DSPCON  ; R0 ← DSPCON data
    AND    R0,#0F0H    ; 11110000b, bit0-bit3 clear
    CP     R0,#10H     ; Row 1 interrupt?
    JR     NE, No_Char_Change
    LD      CHACON,#50H ; Double size character at row 2
    JR     t, Row_interrupt_end

```

No_char_change:

```

    LD      CHACON, #00H ; X1 size character except row 2

```

Row_interrupt_end:

```

    POP    R0
    LD      HTCON, #23H ; Pending bit clear
    IRET

```

 **PROGRAMMING TIP — Writing Character Code and Color Data to the OSD Video RAM**

This example shows how to write character code and color data to the OSD video RAM. The sample program performs the following operations:

1. Write red character 'A' (code 0A, for example) to the video RAM from address 00H to 77H.
2. Write green character 'B' (code 0B, for example) to the video RAM from address 78H to 0FBH.

```

      •
      •
      •
      SB1                ; Select bank 1
      LD      DSPCON,#0F9H ; OSD module on; negative sync trigger is selected
      LD      OSDCOL,#0    ; Digital RGB selection
      LD      PP,#11H     ; Select OSD video RAM page (page 1)
      SRP0    #0C0H      ; Select common working register area
      LD      COLBUF,#04H  ; Load color buffer (red color)
      CLR     R0          ; Load starting address (00H) to R0
OSDLP1 LD      @R0,#0AH    ; Write red character A to video RAM address 00H–77H
      INC     R0          ;
      CP     R0,#77H      ;
      JP     ULE,OSDLP1   ;
      LD      COLBUF,#02H  ; Load green color code (02H) to the color buffer
OSDLP2 LD      @R0,#0BH    ; Write green character B to RAM address 78H–0FBH
      INC     R0          ;
      CP     R0,#0FBH    ;
      JP     ULE,OSDLP2   ;
      SB0                ; Select bank 0
      •
      •
      •

```

 **PROGRAMMING TIP — OSD Fade Function; Line and Row Counters**

This example is a continuation of the previous OSD example in which character code and color data were written to the video RAM. Assuming a timer A interrupt interval of 2 milliseconds, the sample program should meet the following specifications:

1. If bit fade (R4.0) is set, then enable the fade function.
2. Interval time between two lines = 20 ms. (The flag 'INTVAL' is set at 20-ms intervals in the timer A service routine.)
3. Fade direction is 'fade after'.

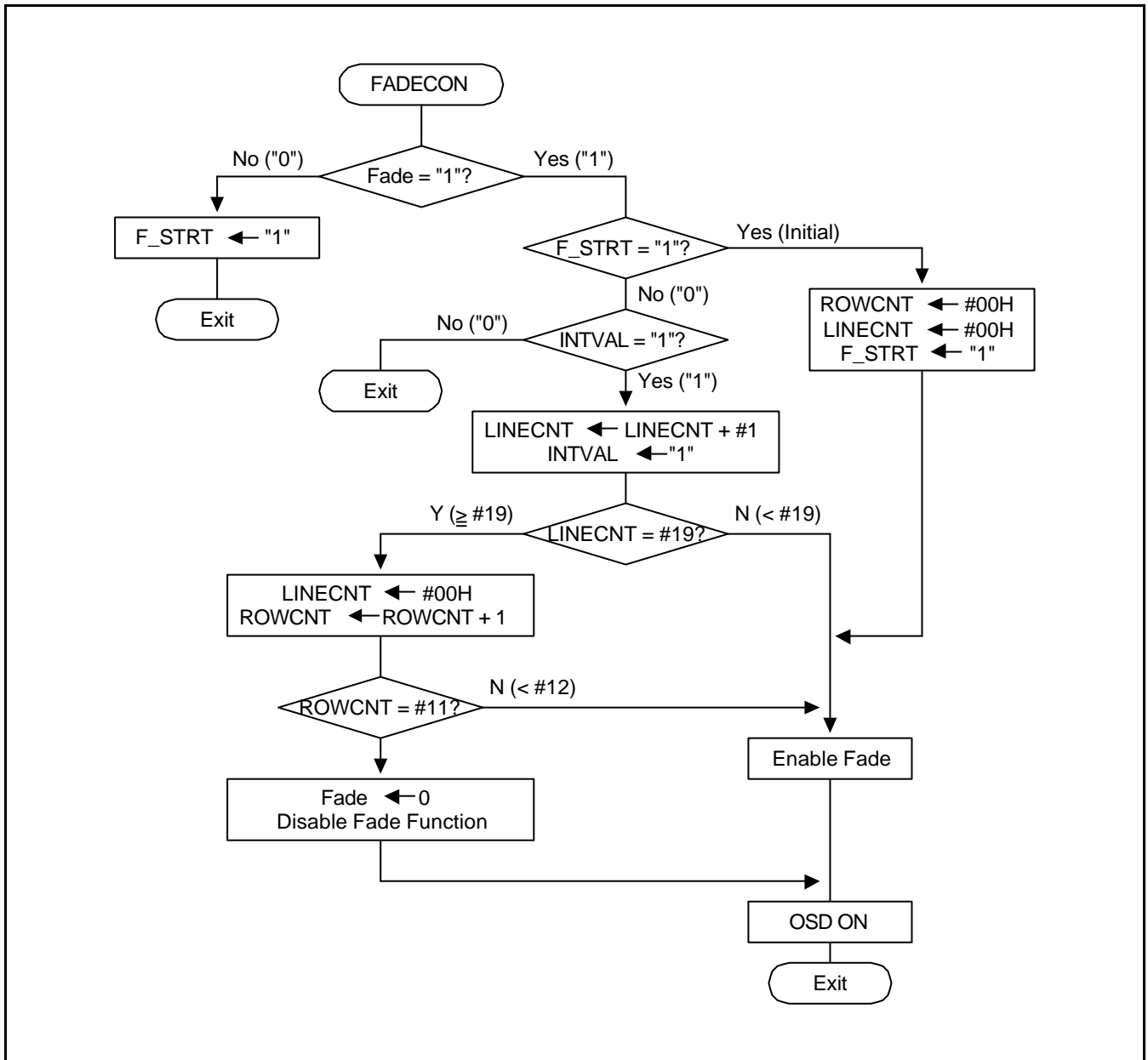


Figure 13-38. Decision Flowchart for Fade Function Programming Tip

 **PROGRAMMING TIP — OSD Fade Function; Line and Row Counters (Continued)**

```

ROWCNT EQU      6
LINECNT EQU      7
FADE    EQU      0
F_STRT  EQU      1
INT_CNT EQU      5
INTVAL  EQU      2
      .
      .
      .
      SB1          ; Select bank 1
      LD          PP,#11H      ; Select OSD video RAM page (page 1)
      SRP0        #0C0H      ; RP0 ← 0C0H (common working register area)
      BTJRF      EXIT1,R4.FADE ; If flag FADE = "0", then jump to EXIT1
      BTJRT      FAD1,R4.F_STRT ; If F_STRT = "1", then jump to FAD1
      BTJRF      EXIT,R4.INTVAL ; If INTVAL = "1", then jump to EXT
      INC        RLINECNT      ; Line counter ← line counter + 1
      BITR       R4.INTVAL     ; INTVAL ← "0"
      CP         RLINECNT,#13H ; Line counter ≥ 19?
      JP         ULT,FAD2      ; If line counter < 19, then jump to FAD2
      CLR        RLINECNT     ; Line counter ← "0"
      INC        RROWCNT      ; Row counter ← row counter + 1
      CP         RROWCNT,#0DH  ; Row counter < 11?
      JP         ULT,FAD2      ; If row ≤ 12, then jump to FAD2
      LD         R1,#0F1H     ; If row > 12, then finish the fade function
      LD         R2,@R1
      BITR       R2.6         ; Fade disable
      LD         @R1,R2

FAD3    LD        DSPCON,#0F9H ; OSD module on
      JR         T,EXIT

```

(Continued on next page)

👉 **PROGRAMMING TIP — OSD Fade Function; Line and Row Counters (Continued)**

```

FAD1      CLR      RROWCNT      ; Row counter (R6) ← 0H
          CLR      RLINECNT     ; Line counter (Rn) ← 0H
          BITS     R4.F_STRT

FAD2      LD       R2,CHACON    ; R2 ← CHACON
          AND      R2,#0F0H     ; Clear the fade row address
          OR       R2,RROWCNT   ; Load new fade row address to R2
          LD       CHACON,R2   ; CHACON ← R2
          INC      R1           ; R1 ← 0F1H (fade line address)
          LD       R2,RLINECNT  ; R2 ← new fade line address
          OR       R2,#60H     ; Enable fade function, select fade after
          LD       FADECN,R2
          JR       T,FAD3


EXIT1     BITS     R4.F_STRT

EXIT      SB0          ; Select bank 0
          .
          .
          .

TAINT     PUSH     PP
          PUSH     RP0
          LD       PP,#11      ; Select video RAM page (page 1)
          SRP0     #0C0H      ; RP0 ← 0C0H
          INC      RINT_CNT    ; Interval counter ← interval counter + 1
          CP       RINT_CNT,#0AH ; Interval counter ≤ 10? (Has 20 ms elapsed?)
          JP       ULE,TA1     ; If yes, then jump to TA1
          CLR      RINT_CNT    ; 20 ms has elapsed, so clear interval counter
          BITS     R4.INTVAL   ; INTVAL ← "1"

TA1       NOP
          .
          .
          .
          POP      RP0
          POP      PP
          IRET

```

 **PROGRAMMING TIP — Manipulating OSD Character Colors; Halftone Function**

This example is a continuation of the previous OSD examples. Following the second sample program, red character A is in the video RAM address 00H–77H and green character B has been written to addresses 78H–0EFH. The program performs the following additional actions:

1. Change the color of character 'A' to white.
2. Change the color of character 'B' to its complementary color.
3. Enable the halftone function for character 'B'.

```

•
•
•
SB1          ; Select bank 1
LD           PP,#11H      ; Select video RAM page (page 1)
SRP0        #0C0H      ; RP0 ← 0C0H (common working register area)
LD          COLBUF,#0FH  ; Color buffer ← white color code (07H), character
                        ; background enable
OSDLP1      CLR         R0      ; R0 (video RAM address) ← 00H
LD          @R0,#0AH     ; Video RAM (00H–77H) ← white 'A'
INC         R0           ; "
CP         R0,#77H      ; "
JP         ULE,OSDLP1   ; "
LD          R2,COLBUF   ; R2 ← color buffer (color of character in address 78H)
COM         R2          ; R2 ← (not R2)
AND        R2,#0FH     ; Mask out bit 7 through bit 3 of R2
LD          COLBUF,R2   ; Color buffer ← complementary color of the character
                        ; in address 78H
LD          DSPCON,#0F9H ; OSD module on; negative sync trigger selected
•
•
•

```

(Continued on next page)

👉 **PROGRAMMING TIP — Manipulating Character Colors; Halftone Function (Continued)**

```

halftone    CALL    halftone1        ; Halftone signal control
            .
            .
            .

halftone1   PUSH    PP                ; Stack ← PP
            PUSH    RP0              ; Stack ← RP0
            PUSH    FLAGS            ; Save flags to stack
            SB1     ; Select bank 1
            LD      PP,#11H          ; Page 1 selected
            SRP0    #20H            ; RP0 ← 20H (working register area)
            CLR     R0               ; R0 ← 00H

loop_halftone
            LD      HTCON,#02H       ; Disable halftone control register
            ; Enable V-sync interrupt
            LD      DSPCON,#09H      ; Enable OSD; select negative sync trigger
            LD      R1,@R0          ; Video RAM zero address
            INC     R0
            CP      R0,#0FBH        ; Video RAM end?
            JP      UGT,end_halftone
            tm      COLBUF,#08H     ; Check COLBUF.3 (character background enable?)
            JR      Z,loop_halftone
            LD      HTCON,#0AH       ; Enable halftone
            ; Enable V-sync interrupt
            LD      DSPCON,#0DH     ; Halftone output mode
            ; Select negative sync trigger
            ; No line is double size

            JP      t,loop_halftone

end_halftone
            POP     FLAGS            ; Restore flag values from stack
            POP     RP0              ; Restore register pointer 0 value
            POP     PP               ; Restore page pointer
            RET     ; Return
            .
            .
            .

```


 **PROGRAMMING TIP — OSD Character Size, Background Color, and Display Position**

This example is a continuation of the previous OSD examples. It performs the following additional actions:

1. Change the character size to horizontal $\times 3$ and vertical $\times 2$.
2. Enable character background color to the complementary color of the character code in address 0EFH of the video RAM.
3. Enable the frame background; select the color cyan.
4. Set top margin to 16H, inter-row spacing to 1H, left margin to 24 dots, and inter-column spacing to three (3) dots.

```

•
•
•
SB1                ; Select bank 1
LD      PP,#11H     ; Select video RAM page (page 1)
SRP0    #0C0H      ; Select common working register area
LD      COLCON,#0   ; Digital RGB selection
LD      CHACON,#60H ; Horizontal  $\times 3$ , vertical  $\times 2$  for character size
LD      FADECON,#00H ; Disable the fade function
LD      ROWCON,#21H ; Top margin  $\leftarrow$  16H, inter-row space  $\leftarrow$  1H
LD      CLMCON,#1BH ; Left margin  $\leftarrow$  24 dots, inter-column space  $\leftarrow$  3 dots
LD      R3,COLBUF   ; R3  $\leftarrow$  color of the character in address 0EFH
COM     R3          ; R3  $\leftarrow$  not R3
AND     R3,#07H     ; Mask out bit 7 through bit 3 of R3
OR      R3,#0B8H    ; R3  $\leftarrow$  cyan frame background color
LD      COLBUF,R3   ; Enable character and frame background color
LD      DSPCON,#09H ; Falling edge sync trigger, OSD on
SB0                ; Select bank 0
•
•
•

```

 **PROGRAMMING TIP — Helpful Hints About COLBUF and OSD Character Code 0**

When working with the OSD module, please note the somewhat unusual characteristics of the color buffer register (COLBUF) and the OSD character code 0:

- The color buffer register, COLBUF (F7C, set 1, bank 1) provides a somewhat unusual method for manipulating character color data.
- OSD character code 0 produces a no-display and no-background condition, regardless of the font coding used.

NOTES

14 ANALOG-TO-DIGITAL CONVERTER

OVERVIEW

The 8-bit A/D converter (ADC) module uses successive approximation logic to convert analog levels entering at one of the four input channels to equivalent 8-bit digital values. The analog input level must lie between the V_{DD} and V_{SS} values. The A/D converter has the following components:

- Analog comparator with successive approximation logic
- D/A converter logic (resistor string type)
- ADC control register (ADCON)
- Four multiplexed analog data input pins (ADC0–ADC3)
- 8-bit A/D conversion data output register (ADDATA)

To initiate an analog-to-digital conversion procedure, you write the channel selection data in the A/D converter control register ADCON to select one of the four analog input pins (ADC n , $n = 0-3$) and set the conversion start or enable bit, ADCON.0. The read-write ADCON register is located at address FAH.

During a normal conversion, A/D C logic initially sets the successive approximation register to 80H (the approximate half-way point of an 8-bit register). This register is then updated automatically during each conversion step. The successive approximation block performs 8-bit conversions for one input channel at a time. You can dynamically select different channels by manipulating the channel selection bit value (ADCON.5–4) in the ADCON register. To start the A/D conversion, you should set the enable bit, ADCON.0. When a conversion is completed, ADCON.3, the end-of-conversion (EOC) bit is automatically set to 1 and the result is dumped into the ADDATA register where it can be read. The A/D converter then enters an idle state. Remember to read the contents of ADDATA before another conversion starts. Otherwise, the previous result will be overwritten by the next conversion result.

NOTE

Because the ADC does not use sample-and-hold circuitry, it is important that any fluctuations in the analog level at the ADC0–ADC3 input pins during a conversion procedure be kept to an absolute minimum. Any change in the input level, perhaps due to circuit noise, will invalidate the result.

USING A/D PINS FOR STANDARD DIGITAL INPUT

The ADC module's input pins are alternatively used as digital input in port 0 and port 3. The ADC0–ADC1 share pin names are P3.0–P3.1 and ADC2–ADC3 share pin names are P0.6–P0.7, respectively.

A/D CONVERTER CONTROL REGISTER (ADCON)

The A/D converter control register, ADCON, is located at address FAH. Only bits 5-0 are used in the S3C880A/F880A implementation. ADCON has three functions:

- Bits 5–4 select an analog input pin (ADC0–ADC3).
- Bit 3 indicates the status of the A/D conversion.
- Bit 2-1 select a conversion speed.
- Bit 0 starts the A/D conversion.

Only one analog input channel can be selected at a time. You can dynamically select any one of the four analog input pins (ADC0–ADC3) by manipulating the 2-bit value for ADCON.5–ADCON.4.

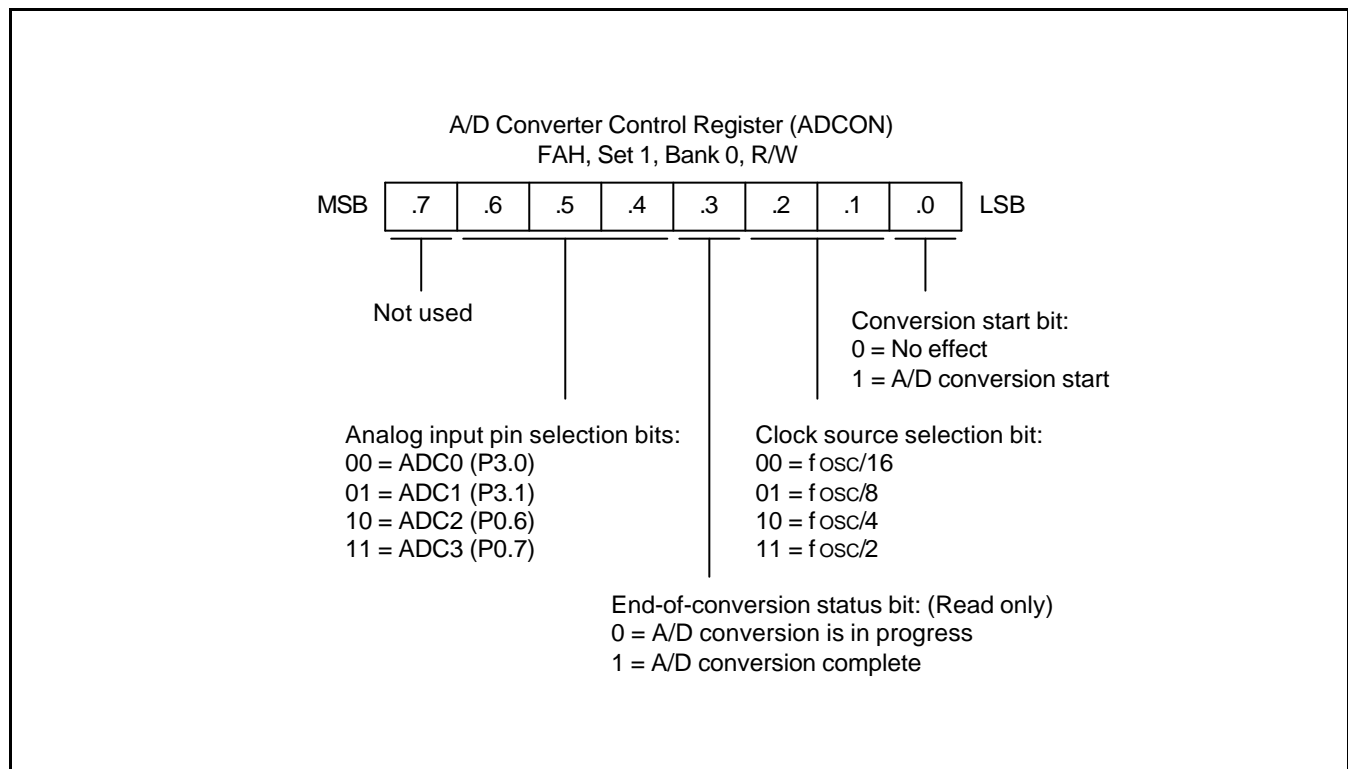


Figure 14-1. A/D Converter Control Register (ADCON)

INTERNAL REFERENCE VOLTAGE LEVELS

In the ADC function block, the analog input voltage level is compared to the reference voltage. The analog input level must remain within the range AV_{SS} to AV_{REF} (usually, $AV_{REF} = V_{DD}$).

Different reference voltage levels are generated internally along the resistor tree during the analog conversion process for each conversion step. The reference voltage level for the first bit conversion is always $1/2 AV_{REF}$.

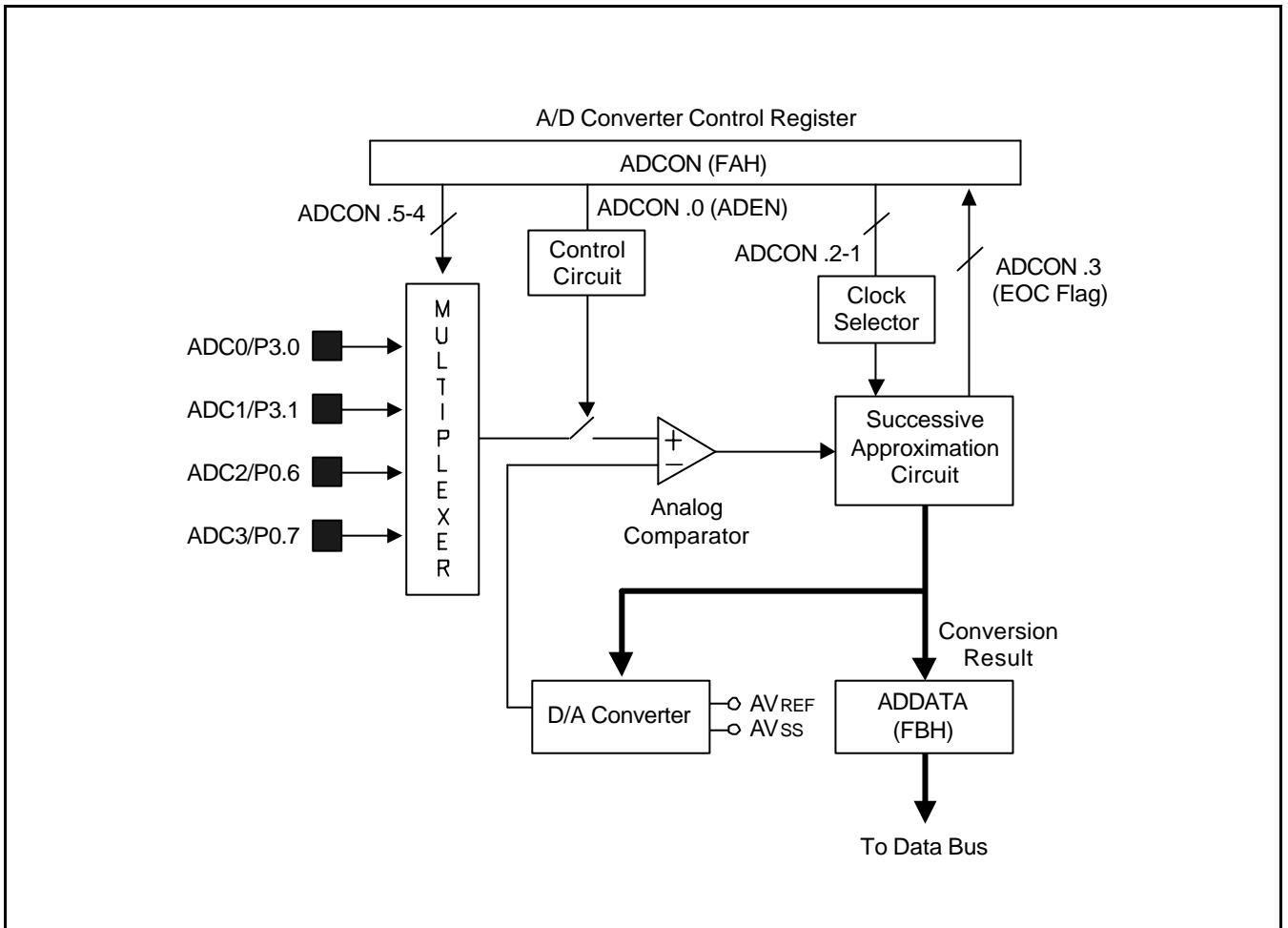


Figure 14-2. A/D Converter Circuit Diagram

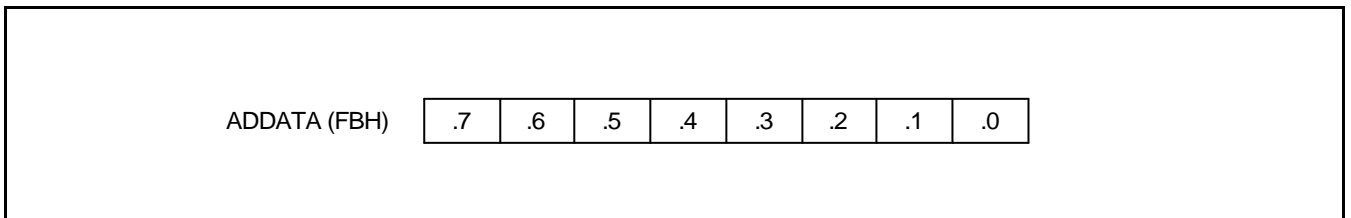


Figure 14-3. A/D Converter Data Register (ADDATA)

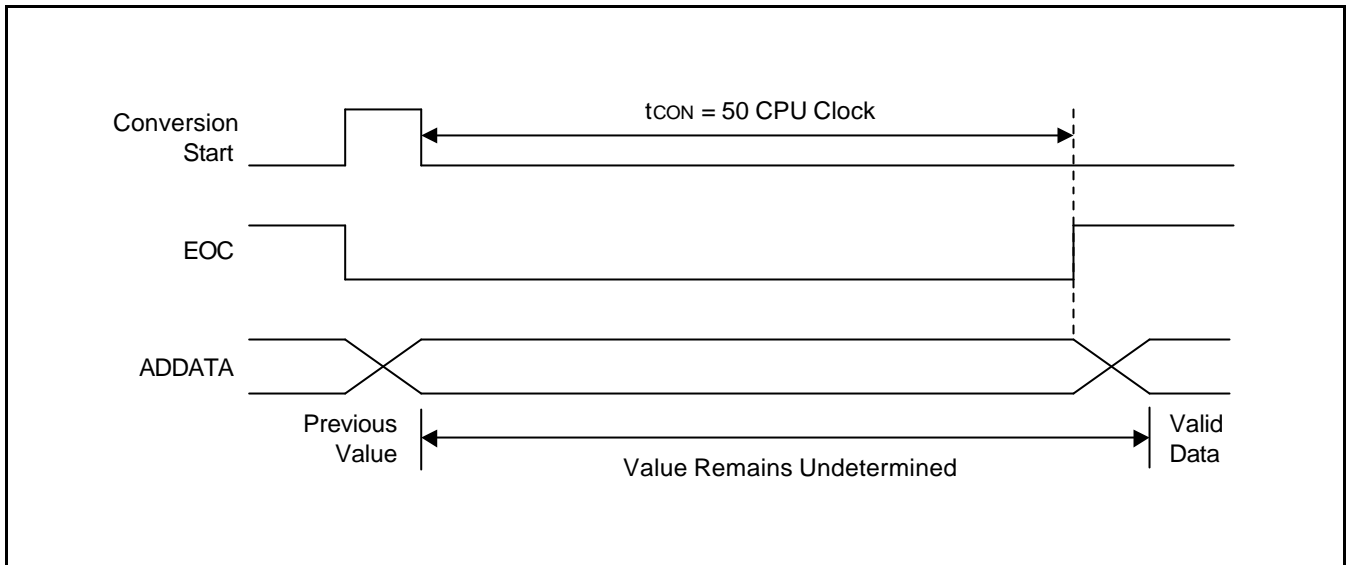


Figure 14-4. S3C880A/F880A A/D Converter Timing Diagram

CONVERSION TIMING

The A/D conversion process requires 4 steps (4 clock edges) to convert each bit and 18 clocks to step-up A/D conversion. Therefore, total of 50 clocks are required to complete an 8-bit conversion: With an 10 MHz CPU clock frequency, one clock cycle is 100 ns. If each bit conversion requires 4 clocks, the conversion rate is calculated as follows:

$$4 \text{ clocks/bit} \times 8\text{-bits} + \text{step-up time (18 clock)} = 50 \text{ clocks}$$

$$50 \text{ clock} \times 100 \text{ ns} = 5 \mu\text{s at } 10 \text{ MHz, } 1 \text{ clock time} = \text{CPU clock}$$

INTERNAL A/D CONVERSION PROCEDURE

1. Analog input must remain between the voltage range of AV_{SS} and AV_{REF} .
2. Configure the analog input pins to input mode by making the appropriate settings in P3CONL and P0CONH registers.
3. Before the conversion operation starts, you must first select one of the four input pins (ADC0–ADC3) by writing the appropriate value to the ADCON register.
4. When conversion has been completed, (50 CPU clocks have elapsed), the EOC flag is set to "1", so that a check can be made to verify that the conversion was successful.
5. The converted digital value is loaded to the output register, ADDATA, than the ADC module enters an idle state.
6. The digital conversion result can now be read from the ADDATA register.

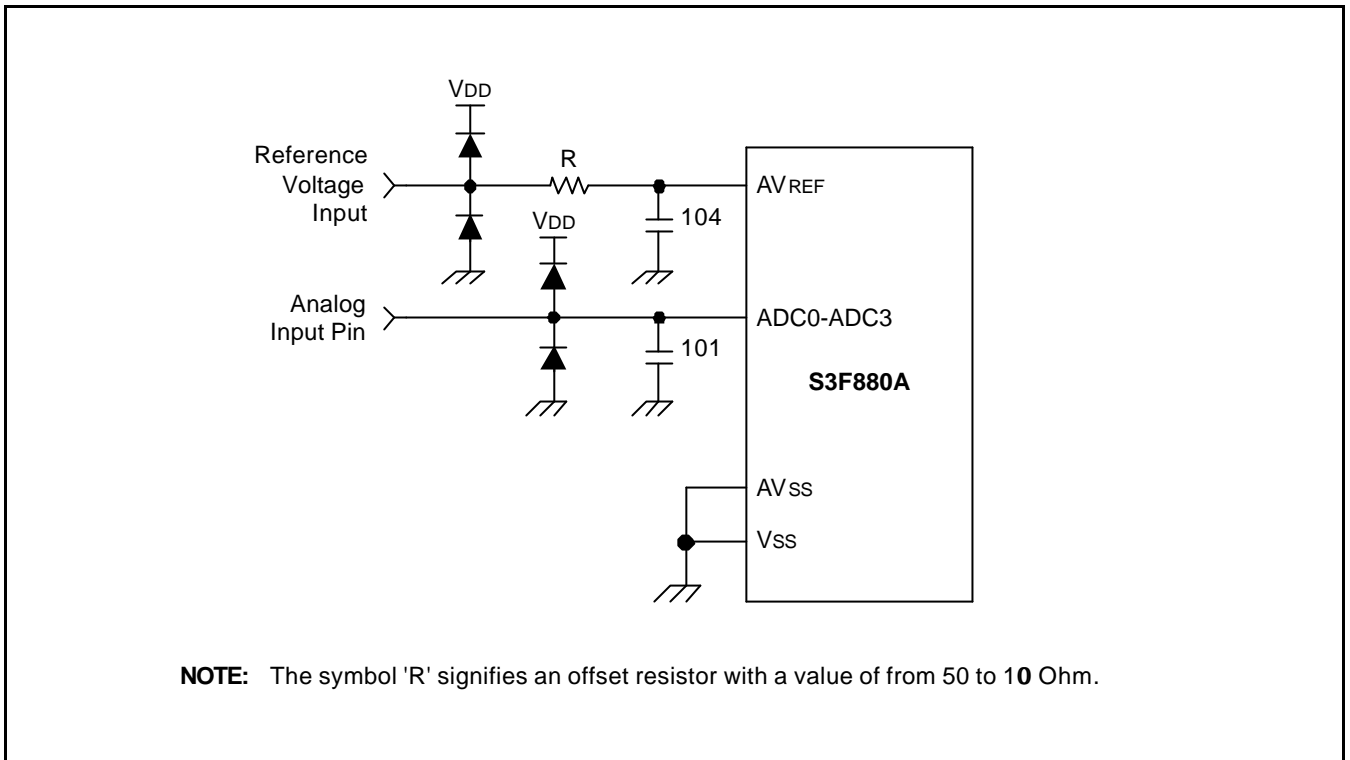


Figure 14-5. Recommended A/D Converter Circuit for Highest Absolute Accuracy

PROGRAMMING TIP – Configuring A/D Converter

```

•
•
•
LD      P3CONL,#00000101B      ; P3.1-0 A/D Input MODE
LD      P0CONH,#01010000B      ; P0.7-6 A/D Input MODE
•
•
•
LD      ADCON,#00000001B       ; channel ADC0: P3.0/conversion start
AD0_CHK: TM      ADCON,#00001000B ; A/D conversion end ? → EOC check
JR      Z,AD0_CHK              ; no
LD      AD0BUF,ADDATA          ; Conversion data
•
•
•
LD      ADCON,#00010001B       ; channel ADC1: P3.1/conversion start
AD1_CHK: TM      ADCON,#00001000B ; A/D conversion end ? → EOC check
JR      Z,AD1_CHK              ; no
LD      AD1BUF,ADDATA          ; Conversion data
•
•

```

NOTES

15 ELECTRICAL DATA

OVERVIEW

In this section, S3C880A/F880A electrical characteristics are presented in tables and graphs. The information is arranged in the following order:

- Absolute maximum ratings
- D.C. electrical characteristics
- I/O capacitance
- A.C. electrical characteristics
- Input timing measurement points for t_{NF1} and t_{NF2}
- Data retention supply voltage in Stop mode
- Stop mode release timing when initiated by nRESET
- Main oscillator and L-C oscillator frequency
- Clock timing measurement points for X_{IN}
- Main oscillator clock stabilization time (t_{ST})
- A/D converter electrical characteristics
- Characteristic curves

Table 15-1. Absolute Maximum Ratings

 $(T_A = 25^\circ\text{C})$

Parameter	Symbol	Conditions	Rating	Unit
Supply Voltage	V_{DD}	–	– 0.3 to + 6.0	V
Input Voltage	V_{I1}	P1.0–P1.5 (open-drain)	– 0.3 to + 7	V
	V_{I2}	All port pins except V_{I1}	– 0.3 to $V_{DD} + 0.3$	
Output Voltage	V_O	All output pins	– 0.3 to $V_{DD} + 0.3$	V
Output Current High	I_{OH}	One I/O pin active	– 18	mA
		All I/O pins active	– 60	
Output Current Low	I_{OL}	One I/O pin active	+ 30	mA
		Total pin current for port 1	+ 100	
		Total pin current for ports 0, 2, and 3	+ 100	
Operating Temperature	T_A	–	– 20 to + 85	$^\circ\text{C}$
Storage Temperature	T_{STG}	–	– 65 to + 150	$^\circ\text{C}$

Table 15-2. D.C. Electrical Characteristics

 $(T_A = -20^\circ\text{C to } +85^\circ\text{C}, V_{DD} = 4.5\text{ V to } 5.5\text{ V})$

Parameter	Symbol	Conditions	Min	Typ	Max	Unit
Input High Voltage	V_{IH1}	All input pins except V_{IH2}	$0.8 V_{DD}$	–	V_{DD}	V
	V_{IH2}	X_{IN}, X_{OUT}	2.7 V			
Input Low Voltage	V_{IL1}	All input pins except V_{IL2}	–	–	$0.2 V_{DD}$	V
	V_{IL2}	X_{IN}, X_{OUT}			1.0 V	
Output High Voltage	V_{OH}	$I_{OH} = -500\ \mu\text{A}$ P0.0–P0.5, P1.6–P1.7, P2 R, G, B (digital level), Vblank	$V_{DD} - 0.8$	–	–	V
Output Low Voltage	V_{OL1}	$I_{OL} = 4\ \text{mA}$ P0.0–P0.5, P1.6–P1.7	–	–	0.5	V
	V_{OL2}	$I_{OL} = 10\ \text{mA}$ P1.4–P1.5	–	–	0.8	
	V_{OL3}	$I_{OL} = 2\ \text{mA}$ P1.0–P1.3, P3.0–P3.1, P0.6–P0.7	–	–	0.5	
	V_{OL4}	$I_{OL} = 1\ \text{mA}$ R, G, B (digital level), Vblank, P2	–	–	0.4	V

Table 15-2. D.C. Electrical Characteristics (Continued)

(T_A = -20°C to +85°C, V_{DD} = 4.5 V to 5.5 V)

Parameter	Symbol	Conditions	Min	Typ	Max	Unit
Input High Leakage Current	I _{LH1}	V _{IN} = V _{DD} All input pins except I _{LH2} and I _{LH3}	–	–	1	μA
	I _{LH2}	V _{IN} = V _{DD} , OSC _{IN} , OSC _{OUT}			10	
	I _{LH3}	V _{IN} = V _{DD} , X _{IN} , X _{OUT}	2.5	10	20	
Input Low Leakage Current	I _{LIL1}	V _{IN} = 0 V All input pins except I _{LIL2} , I _{LIL3} , and nRESET	–	–	–1	μA
	I _{LIL2}	V _{IN} = 0 V, OSC _{IN} , OSC _{OUT}			–10	
	I _{LIL3}	V _{IN} = 0 V, X _{IN} , X _{OUT}	–2.5	–10	–20	
Output High Leakage Current	I _{LOH1}	V _{OUT} = V _{DD} All output pins except I _{LOH2}	–	–	1	μA
	I _{LOH2}	V _{OUT} = 6 V P1.0–P1.5			10	
Output Low Leakage Current	I _{LOL}	V _{OUT} = 0 V All output pins	–	–	–1	μA
Supply Current (note)	I _{DD1}	Normal mode; V _{DD} = 4.5 V to 5.5 V 8-MHz CPU clock	–	7	20	mA
	I _{DD2}	Idle mode; V _{DD} = 4.5 V to 5.5 V 8-MHz CPU clock		4	10	
	I _{DD3}	Stop mode; V _{DD} = 4.5 V to 5.5 V		1	10	μA

NOTE: Supply current does not include the current drawn through internal pull-up resistors or external output current loads.

Table 15-3. Input/Output Capacitance

(T_A = - 20°C to + 85°C, V_{DD} = 0 V)

Parameter	Symbol	Conditions	Min	Typ	Max	Unit
Input capacitance	C _{IN}	f = 1 MHz; unmeasured pins are connected to V _{SS}	-	-	10	pF
Output capacitance	C _{OUT}					
I/O capacitance	C _{IO}					

Table 15-4. A.C. Electrical Characteristics

(T_A = - 20°C to + 85°C, V_{DD} = 4.5 V to 5.5 V)

Parameter	Symbol	Conditions	Min	Typ	Max	Unit
V-sync Pulse Width	t _{VW}	-	4	-	-	μs
H-sync Pulse Width	t _{HW}	-	3	-	-	μs
Noise Filter	t _{NF1}	P1.0-P1.3, H-sync, V-sync	-	350	-	ns
	t _{NF2}	nRESET	-	1000		
	t _{NF3}	Glitch filter (oscillator block)	-	25		
	t _{NF4}	CAPA	-	5	-	t _{CAPA}

NOTE: t_{CAPA} = f_{OSC}/128.

Table 15-5. Analog R,G,B Output

(T_A = - 20°C to + 85°C, V_{DD} = 4.75 V to 5.25 V)

	Output Voltage (50 kW load)			Remark
	V _{DD} = 4.75 V	V _{DD} = 5.00 V	V _{DD} = 5.25 V	
Data = 11	4.00 V ± 0.30 V	4.20 V ± 0.30 V	4.40 V ± 0.30 V	
Data = 10	3.10 V ± 0.25 V	3.35 V ± 0.25 V	3.40 V ± 0.25 V	
Data = 01	1.90 V ± 0.20 V	2.00 V ± 0.20 V	2.10 V ± 0.20 V	
Data = 00	0.00 V - 0.65 V	0.00 V - 0.75 V	0.00 V - 0.75 V	

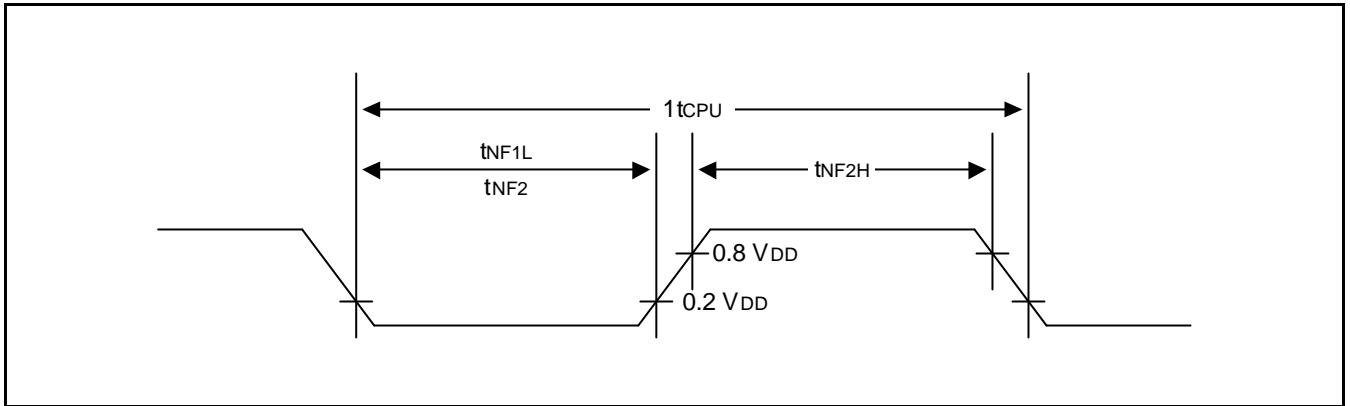


Figure 15-1. Input Timing Measurement Points for t_{NF1} and t_{NF2}

Table 15-6. Data Retention Supply Voltage in Stop Mode

($T_A = -20\text{ }^\circ\text{C}$ to $+85\text{ }^\circ\text{C}$)

Parameter	Symbol	Conditions	Min	Typ	Max	Unit
Data Retention Supply Voltage	V_{DDDR}	Stop mode	2	–	6	V
Data Retention Supply Current	I_{DDDR}	Stop mode, $V_{DDDR} = 2.0\text{ V}$	–	–	5	μA

NOTES:

- Supply current does not include the current drawn through internal pull-up resistors or external output current loads.
- During the oscillator stabilization wait time (t_{WAIT}), all the CPU operations must be stopped.

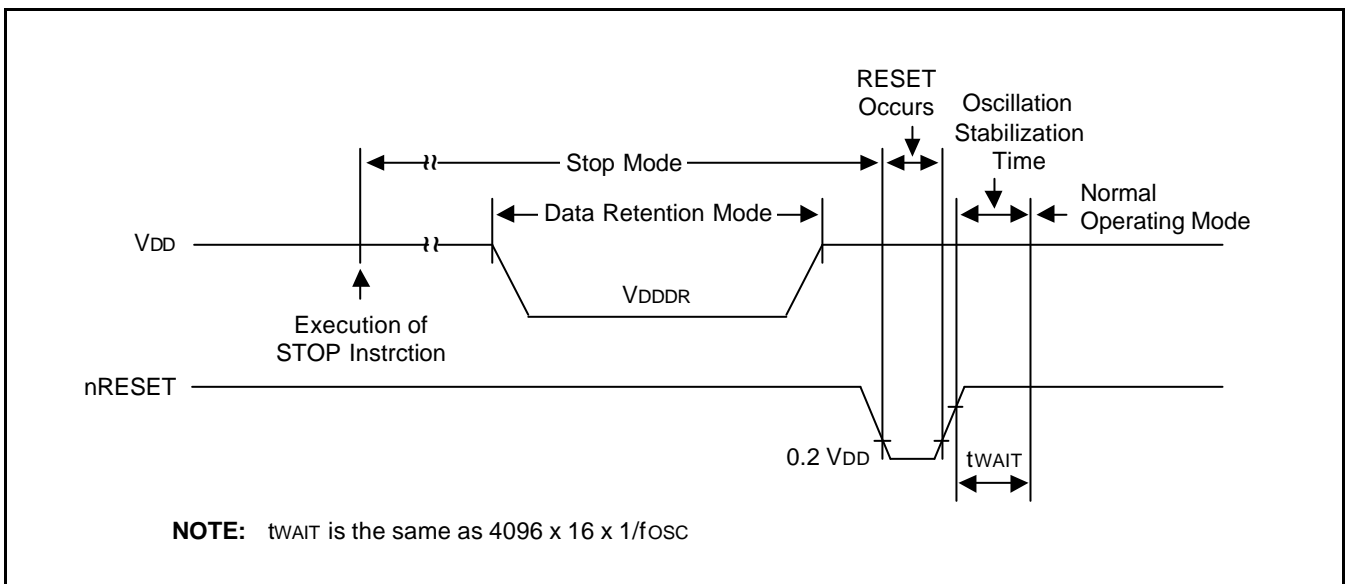
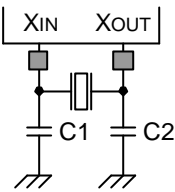
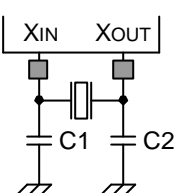
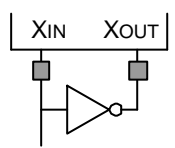
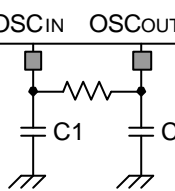


Figure 15-2. Stop Mode Release Timing When Initiated by a nRESET

Table 15-7. Main Oscillator and L-C Oscillator Frequency

 $(T_A = -20^\circ\text{C} + 85^\circ\text{C}, V_{DD} = 4.5\text{ V to } 5.5\text{ V})$

Oscillator	Clock Circuit	Conditions	Min	Typ	Max	Unit
Crystal		OSD block active	5	6	8	MHz
		OSD block inactive	0.5	6	8	
Ceramic		OSD block active	5	6	8	MHz
		OSD block inactive	0.5	6	8	
External Clock		OSD block active	5	6	8	MHz
		OSD block inactive	0.5	6	8	
L-C Oscillator		Recommend value; C1 = C2 = 20 pF	5	6.5	8	MHz
CPU Clock Frequency		–	0.032	6.0	8	MHz

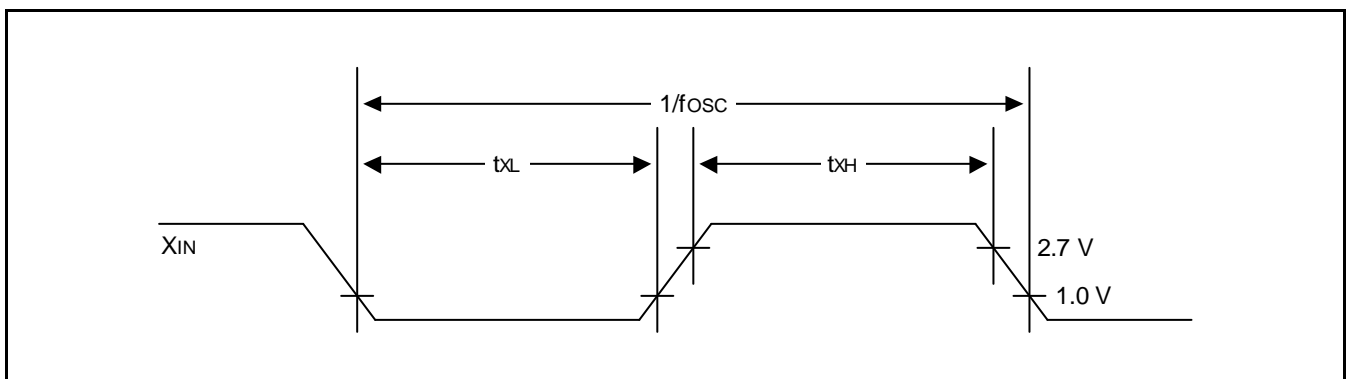
Figure 15-3. Clock Timing Measurement Points for X_{IN}

Table 15-8. Main Oscillator Clock Stabilization Time

(T_A = - 20°C + 85°C, V_{DD} = 4.5 V to 5.5 V)

Oscillator	Symbol	Test Condition	Min	Typ	Max	Unit
Crystal	-	V _{DD} = 4.5 V to 6.0 V	-	-	20	ms
Ceramic		(Oscillation stabilization occurs when V _{DD} is equal to the minimum oscillator voltage range.)			10	
External Clock		X _{IN} input High and Low level width (t _{XH} , t _{XL})			65	
Release Signal Setup Time	t _{SREL}	Normal operation	-	1000	-	ns
Oscillation Stabilization Wait Time (1)	t _{WAIT}	CPU clock = 8 MHz; Stop mode released by nRESET	-	8.3	-	ms
		CPU clock = 8 MHz; Stop mode released by an interrupt		(2)		

NOTES:

- Oscillation stabilization time is the time required for the CPU clock to return to its normal oscillation frequency after a power-on occurs, or when Stop mode is released.
- The oscillation stabilization interval is determined by the basic timer (BT) input clock setting.

Table 15-9. A/D Converter Electrical Characteristics

(T_A = - 20°C to + 85°C, V_{DD} = 4.5 V to 5.5 V, V_{SS} = 0 V)

Parameter	Symbol	Test Conditions	Min	Typ	Max	Unit
Absolute Accuracy		V _{DD} = 5.12 V CPU CLOCK = 8 MHz AV _{REF} = 5.12 V AV _{SS} = 0 V	–	–	± 2	LSB
Conversion Time (1)	t _{CON}	f _{OSC} = 8 MHz	25	–	–	us
Analog Input Voltage	V _{IAN}	–	AV _{SS}	–	AV _{REF}	V
Analog Input Impedance	R _{AN}	–	2	–	–	MΩ
ADC Reference Voltage	AV _{REF}	–	2.5	–	V _{DD}	V
ADC Reference Ground	AV _{SS}	–	V _{SS}	–	V _{SS} + 0.3	V
Analog input current	I _{ADIN}	AV _{REF} = V _{DD} = 5 V	–	–	10	uA
ADC block current (2)	I _{ADC}	AV _{REF} = V _{DD} = 5 V	–	1	3	mA
		AV _{REF} = V _{DD} = 5 V Power down mode	–	100	500	nA

NOTES:

- 'Conversion time' is the time required from the moment a conversion operation starts until it ends.
- I_{ADC} is operating current during A/D conversion.

16 MECHANICAL DATA

OVERVIEW

The S3C880A/F880A microcontrollers are available in 42-pin SIP package (42-SDIP-600), 44-pin QFP package (44-QFP-1010B) .

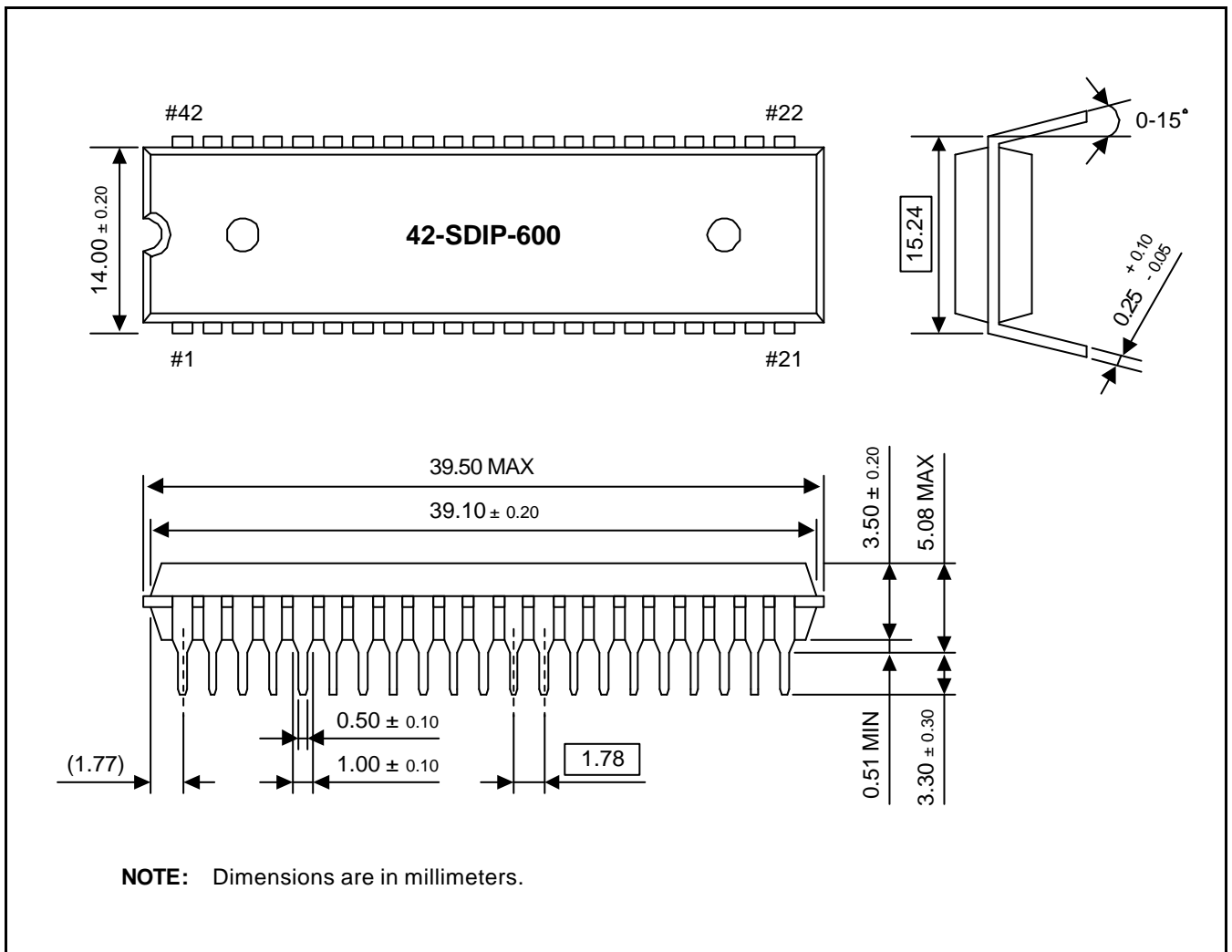


Figure 16-1. 42-Pin SDIP Package Dimensions (42-SDIP-600)

17

S3F880A MTP

OVERVIEW

The S3C880A/F880A single-chip CMOS microcontroller is the MTP flash ROM version. It has an on-chip flash ROM instead of a masked ROM. The flash ROM is accessed by serial data format.

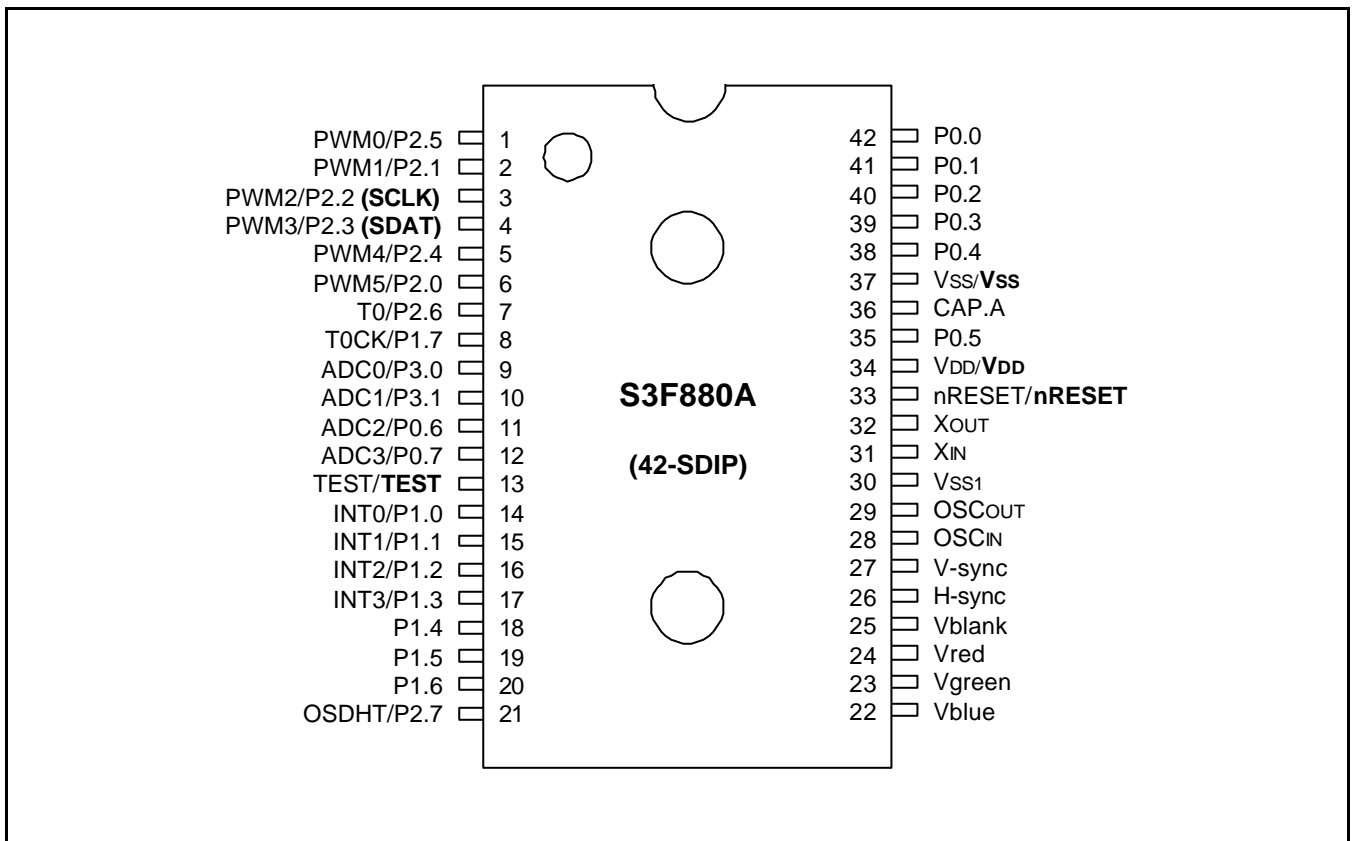


Figure 17-1. S3F880A Pin Assignment (42-SDIP)

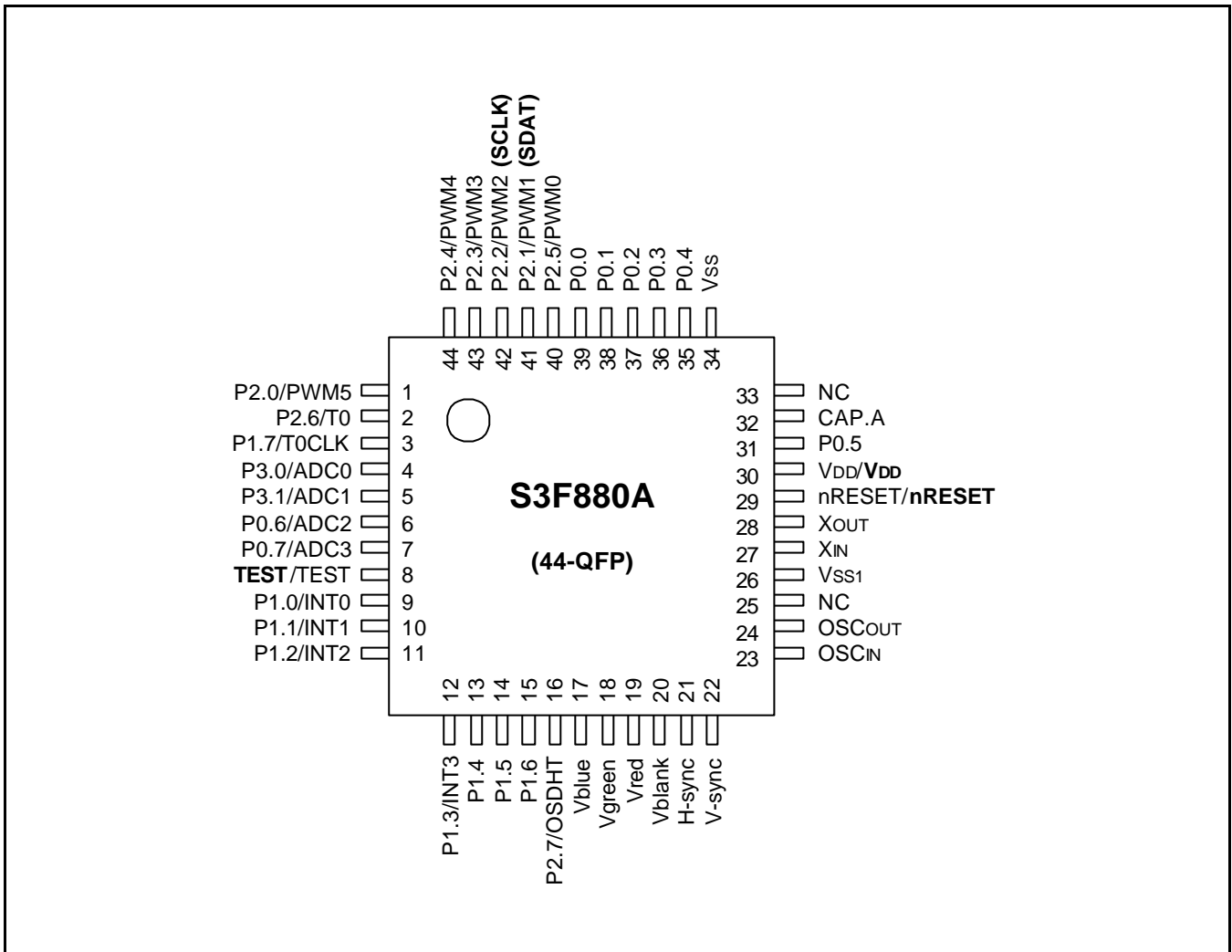


Figure 17-2. S3F880A Pin Assignment (44-QFP)

Table 17-1. Descriptions of Pins Used to Read/Write the Flash ROM (S3F880A)

Main Chip Pin Name	During Programming			
	Pin Name	Pin No.	I/O	Function
P2.3 (Pin 4)	SDAT	4 (43)	I/O	Serial data pin (output when reading, Input when writing) Input and push-pull output port can be assigned
P2.2 (Pin 3)	SCLK	3 (42)	I/O	Serial clock pin (Input only pin)
TEST	V _{PP} (TEST)	13 (8)	I	0 V: operating mode 5 V: test mode 12.5 V: flash ROM writing mode
RESET	RESET	33 (29)	I	5 V: operating mode, 0 V: flash ROM writing mode
V _{DD} /V _{SS}	V _{DD} /V _{SS}	34/30, 37 (30/26, 34)	I	Logic power supply pin.

NOTE: Parentheses indicate pin number for 44-QFP package.

NOTES

18 DEVELOPMENT TOOLS

OVERVIEW

Samsung provides a powerful and easy-to-use development support system in turnkey form. The development support system is configured with a host system, debugging tools, and support software. For the host system, any standard computer that operates with MS-DOS as its operating system can be used. One type of debugging tool including hardware and software is provided: the sophisticated and powerful in-circuit emulator, SMDS2+, for S3C7, S3C8, S3C9 families of microcontrollers. The SMDS2+ is a new and improved version of SMDS2. Samsung also offers support software that includes debugger, assembler, and a program for setting options.

SHINE

Samsung Host Interface for in-circuit Emulator, SHINE, is a multi-window based debugger for SMDS2+. SHINE provides pull-down and pop-up menus, mouse support, function/hot keys, and context-sensitive hyper-linked help. It has an advanced, multiple-windowed user interface that emphasizes ease of use. Each window can be sized, moved, scrolled, highlighted, added, or removed completely.

SAMA ASSEMBLER

The Samsung Arrangeable Microcontroller (SAM) Assembler, SAMA, is a universal assembler, and generates object code in standard hexadecimal format. Assembled program code includes the object code that is used for ROM data and required SMDS program control data. To assemble programs, SAMA requires a source file and an auxiliary definition (DEF) file with device specific information.

SASM88

The SASM88 is an relocatable assembler for Samsung's S3C8-series microcontrollers. The SASM88 takes a source file containing assembly language statements and translates into a corresponding source code, object code and comments. The SASM88 supports macros and conditional assembly. It runs on the MS-DOS operating system. It produces the relocatable object code only, so the user should link object file. Object files can be linked with other object files and loaded into memory.

HEX2ROM

HEX2ROM file generates ROM code from HEX file which has been produced by assembler. ROM code must be needed to fabricate a microcontroller which has a mask ROM. When generating the ROM code.(OBJ file) by HEX2ROM, the value 'FF' is filled into the unused ROM area up to the maximum ROM size of the target device automatically.

TARGET BOARDS

Target boards are available for all S3C8-series microcontrollers. All required target system cables and adapters are included with the device-specific target board.

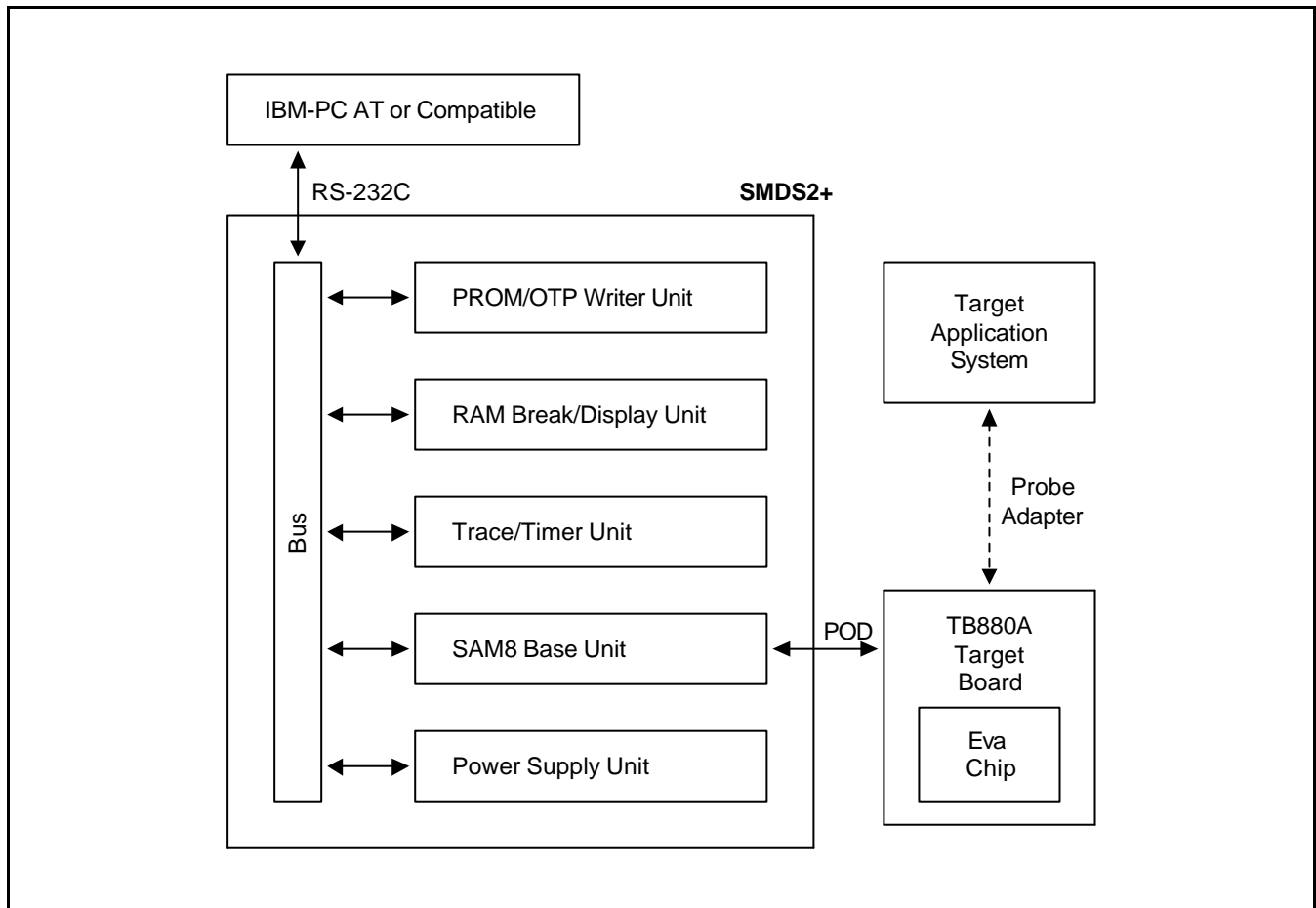


Figure 18-1. SMDS Product Configuration (SMDS2+)

TB880A TARGET BOARD

The TB880A target board is used for the S3C880A/F880A microcontrollers. It is supported with the SMDS2+. The TB880A target board can also be used for S3C880A/F880A.

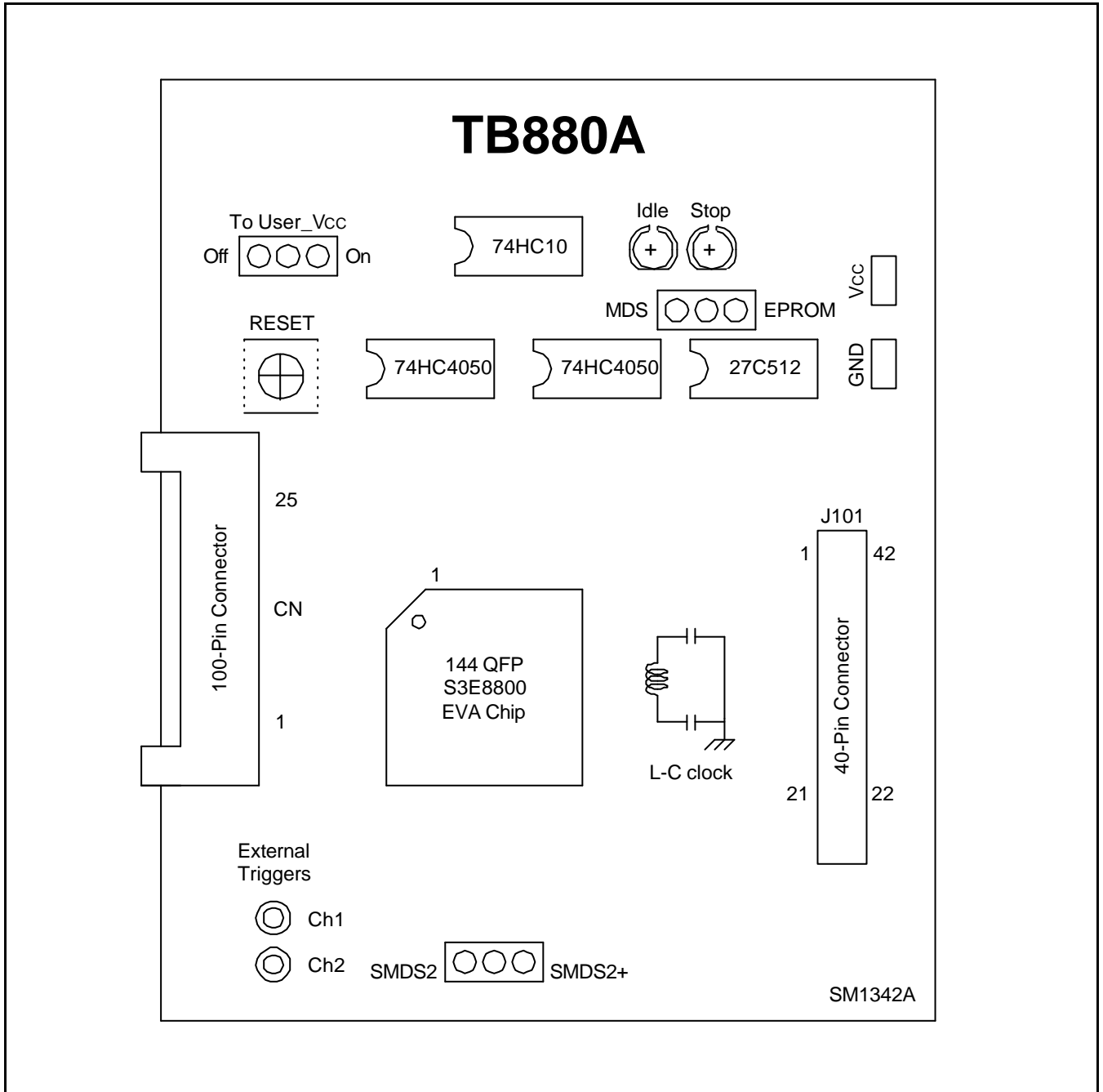

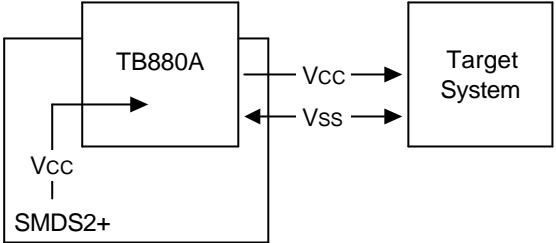

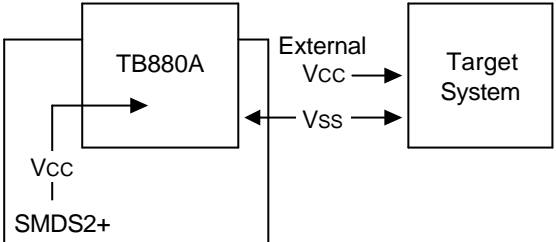


Figure 18-2. TB880A Target Board Configuration

Table 17-1. Power Selection Settings for TB880A

'To User_Vcc' Settings	Operating Mode	Comments
<p>To User_Vcc</p> <p>Off  On</p>		<p>The SMDS2+ main board supplies V_{CC} to the target board (evaluation chip) and the target system.</p>
<p>To User_Vcc</p> <p>Off  On</p>		<p>The SMDS2+ main board supplies V_{CC} only to the target board (evaluation chip). The target system must have its own power supply.</p>


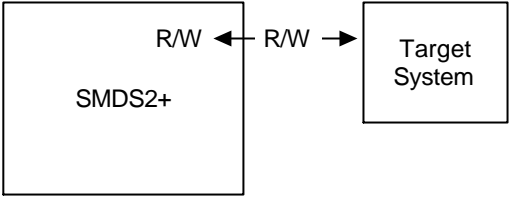
NOTE: The following symbol in the 'To User_Vcc' Setting column indicates the electrical short (off) configuration:



SMDS2+ Selection (SAM8)

In order to write data into program memory that is available in SMDS2+, the target board should be selected to be for SMDS2+ through a switch as follows. Otherwise, the program memory writing function is not available.

Table 17-2. The SMDS2 + Tool Selection Setting

'SW1' Setting	Operating Mode
SMDS2  SMDS2+	 <p>The diagram shows a box labeled 'SMDS2+' on the left and a box labeled 'Target System' on the right. Two horizontal arrows connect them, both labeled 'R/W', indicating bidirectional data flow.</p>

OSD Font ROM Selection

Table 17-3. OSD Font ROM Selection Setting





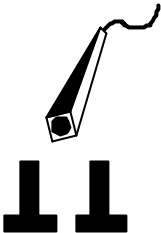
'SW2' Setting	Comments
MDS  EPROM	EPROM (27C512) is used for OSD font ROM
MDS  EPROM	Not used

Table 17-4. Using Single Header Pins as the Input Path for External Trigger Sources

Target Board Part	Comments
<p data-bbox="293 383 384 439">External Triggers</p> <p data-bbox="316 456 427 495">  Ch1 </p> <p data-bbox="316 510 427 548">  Ch2 </p>	<div data-bbox="826 376 986 607" style="text-align: center;">  </div> <p data-bbox="1023 394 1230 506">Connector from External Trigger Sources of the Application System</p> <p data-bbox="627 636 1430 723">You can connect an external trigger source to one of the two external trigger channels (CH1 or CH2) for the SMDS2+ breakpoint and trace functions.</p>

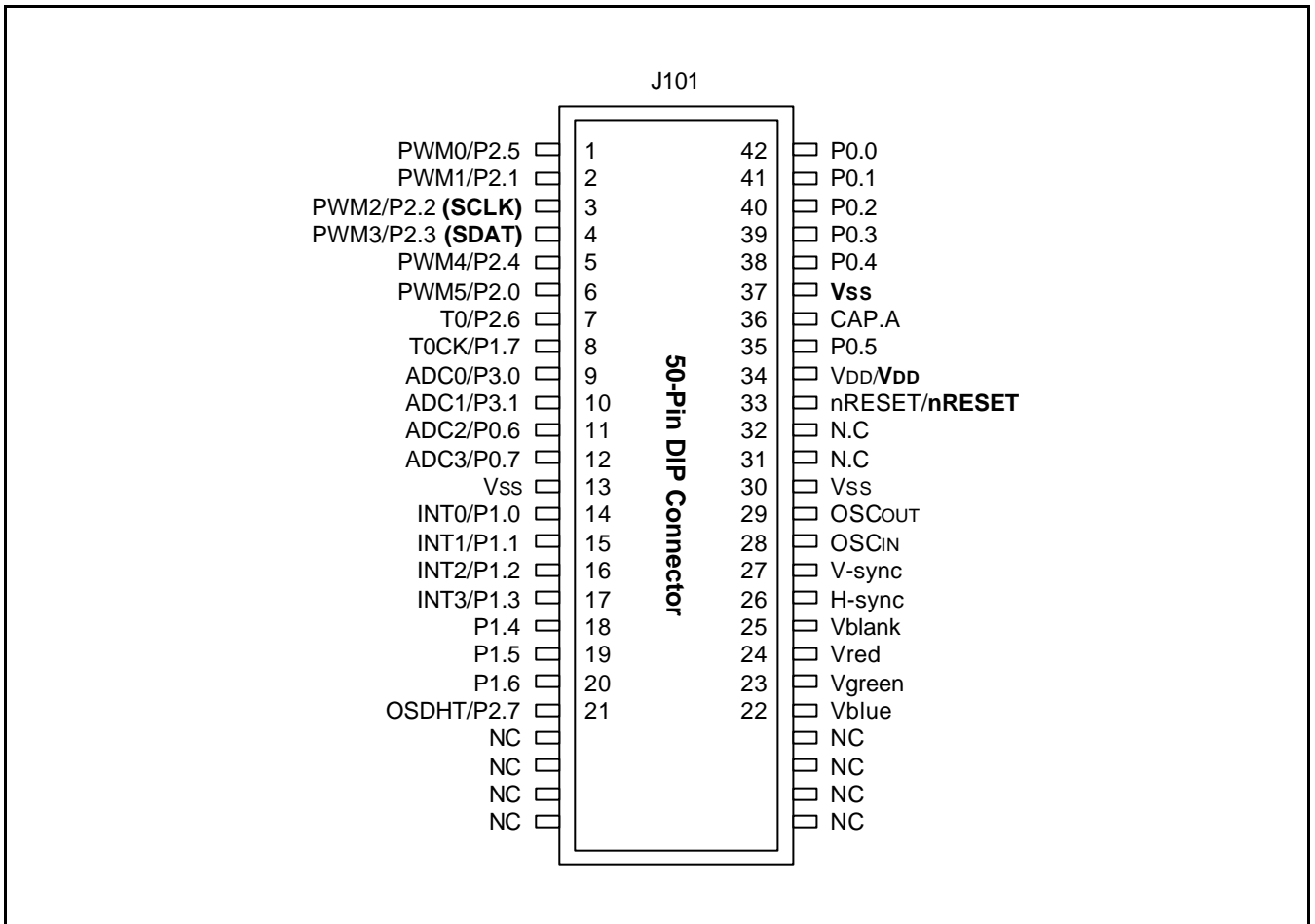


Figure 17-3. 50-Pin DIP Connector J101 for TB880A

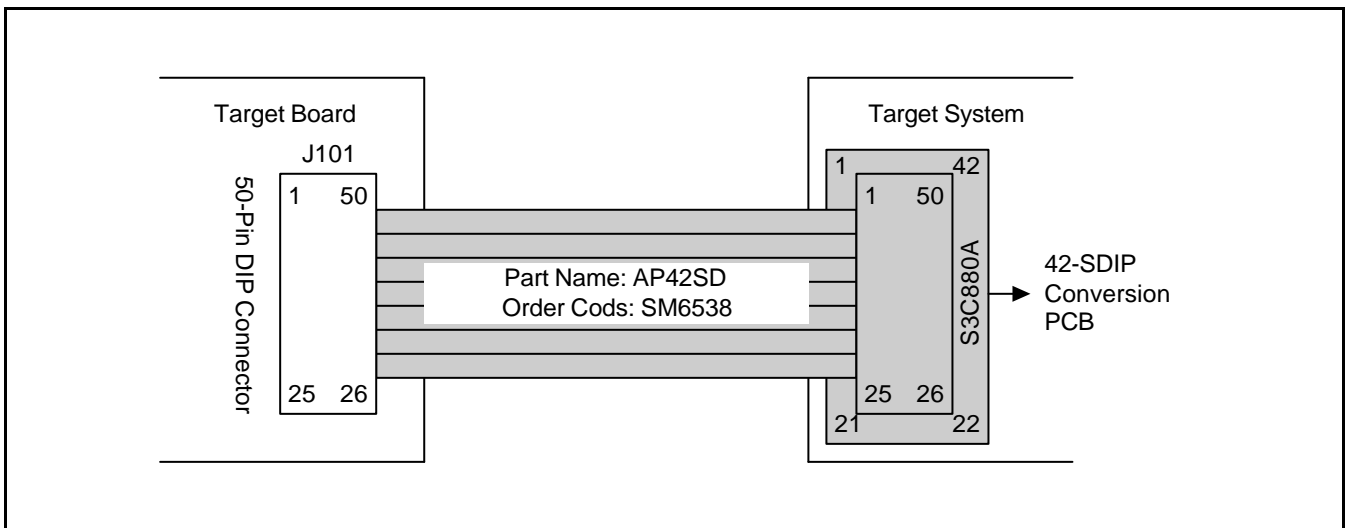


Figure 17-4. S3C880A/F880A Probe Adapter for 42-SDIP Package

NOTES