

400mA SmartOR™ Regulator with V_{AUX} Switch

Features

- Continuous 3.3V output from three inputs
- Complete power management solution
- V_{CC} , V_{SBY} regulator supplies 400mA output
- Built-in hysteresis when selecting input supplies
- Integrated switch has very low $R_{DS(ON)}$ resistance of 0.25Ω (TYP)
- Foldback current limiting protection
- Thermal overload shutdown protection
- 8-pin power SOIC package
- Lead-free version available

Applications

- PCI adapter cards with Wake-On-LAN
- Network Interface Cards (NICs)
- Multiple power systems
- Systems with standby capabilities

Product Description

The CMPWR330 is a dual input regulator with a fully integrated V_{AUX} switch capable of delivering up to 400mA continuously at 3.3V. The input is taken from three independent voltage sources on a prioritized basis. Power is always taken in priority using the order of V_{CC} , V_{SBY} and V_{AUX} .

When V_{CC} (5V) or V_{SBY} is present, the device automatically enables the regulator and produces a stable 3.3V output at V_{OUT} .

When only V_{AUX} (3.3V) is present, the device provides a low impedance direct connection (0.25Ω TYP.) from V_{AUX} to V_{OUT} .

All the necessary control circuitry needed to provide a smooth and automatic transition between all three supplies has been incorporated. This allows the V_{CC} input supply to be dynamically switched without loss of output voltage.

The CMPWR330 is housed in an 8-pin SOIC package and is available with optional lead-free finishing.

Typical Application Circuit

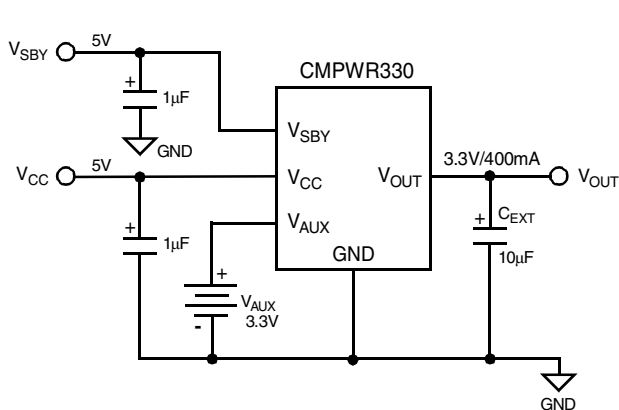

Simplified Electrical Schematic

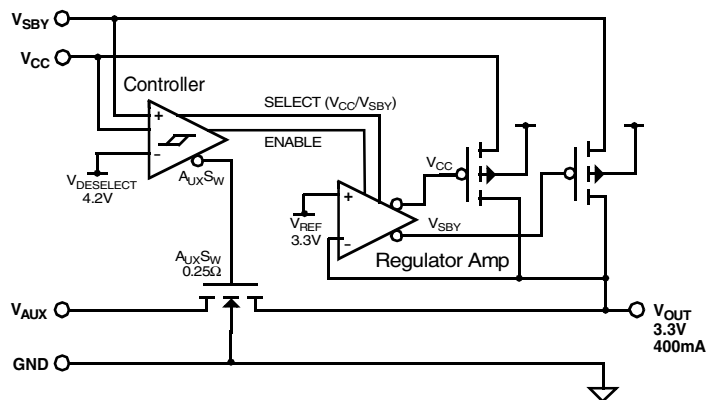



PACKAGE / PINOUT DIAGRAM

TOP VIEW

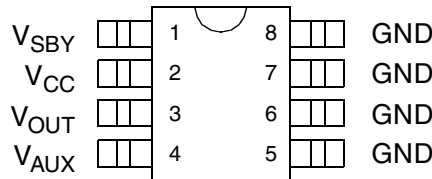

8-pin Power SOIC

Note: This drawing is not to scale.

PIN DESCRIPTIONS

PIN(S)	NAME	DESCRIPTION
1	V _{SBY}	V _{SBY} is the standby input supply (5V), which is used to power the regulator whenever V _{CC} is below the deselect level (4.2V). If the V _{SBY} connection is made within a few inches of the main input filter, a bypass capacitor may not be necessary. Otherwise a bypass filter capacitor in the range of 1μF to 10μF will ensure adequate filtering.
2	V _{CC}	V _{CC} is a positive input supply for the voltage regulator. Whenever this supply voltage exceeds the V _{CCSEL} level (4.4V), it will be given priority and be used to power the regulator output. If this supply voltage falls below the V _{CCDES} level (4.2V) it will immediately be deselected and no longer provide power for the regulator output. An internal hysteresis voltage of 0.2V is used to prevent any chatter during selection and deselection of V _{CC} . The effective source impedance of V _{CC} should be kept below 0.3Ω to ensure changeover disturbances do not exceed the hysteresis level. If the connection to V _{CC} is made within a few inches of the main input filter, a bypass capacitor may not be necessary. Otherwise a bypass filter capacitor in the range of 1μF to 10μF will ensure adequate filtering.
3	V _{OUT}	V _{OUT} is the output voltage. Power is provided from the regulator or via the low impedance auxiliary switch. This output requires a capacitance of 10μF to ensure regulator stability and minimize the peak output disturbance during power supply changeover.
4	V _{AUX}	V _{AUX} is the auxiliary voltage power source. This supply is selected only when V _{CC} falls below 4.2V and the V _{SBY} is not present. Under these conditions an internal switch is enabled and provides a very low impedance connection directly between V _{AUX} and V _{OUT} .
5-8	GND	The negative reference for all voltages. Also functions as a thermal path for heat dissipation.

Ordering Information

PART NUMBERING INFORMATION

Pins	Package	Standard Finish		Lead-free Finish	
		Ordering Part Number ¹	Part Marking	Ordering Part Number ¹	Part Marking
8	Power SOIC	CMPWR330SA	CMPWR330SA	CMPWR330SF	CMPWR330SF

Note 1: Parts are shipped in Tape & Reel form unless otherwise specified.



Specifications

ABSOLUTE MAXIMUM RATINGS		
PARAMETER	RATING	UNITS
ESD Protection (HBM)	±2000	V
Pin Input Voltages V _{CC} , V _{SBY} V _{AUX}	[GND - 0.5] to +6.0 [GND - 0.5] to +4.0	V V
Storage Temperature Range	-40 to +150	°C
Operating Temperature Range Ambient Junction	0 to +70 0 to +125	°C °C
Power Dissipation (See Note 1)	Internally Limited	W

Note 1: At rated load, the power dissipation will be 0.68W (1.7V x 0.4A). Under these conditions, (in a 70°C ambient), the thermal resistance from junction to ambient (θ_{JA}) must not exceed 80°C/W. This is typically achieved with 2 square inches of copper printed circuit board area connected to the GND pins for heat spreading, or equivalent.

STANDARD OPERATING CONDITIONS		
PARAMETER	VALUE	UNITS
V _{CC} , V _{SBY}	5.0 ±0.25	V
V _{AUX}	3.3 ±0.3	V
Ambient Operating Temperature Range	0 to +70	°C
Load Current	0 to 400	mA
C _{EXT}	10 ±20%	µF



Specifications (cont'd)

ELECTRICAL OPERATING CHARACTERISTICS (SEE NOTE 1)						
SYMBOL	PARAMETER	CONDITIONS	MIN	TYP	MAX	UNITS
V _{OUT}	Regulator Output Voltage	0mA < I _{LOAD} < 400mA	3.135	3.300	3.465	V
I _{LIM}	Regulator Current Limit	V _{OUT} > 1V		500		mA
I _{SC}	Short Circuit Current	V _{CC/SBY} = 5V, V _{OUT} = 0V		150		mA
V _{R LOAD}	Load Regulation	V _{CC} = 5V, 5mA ≤ I _{LOAD} ≤ 400mA		20		mV
V _{R LINE}	Line Regulation	I _{LOAD} = 5mA; 4.5V ≤ V _{IN} ≤ to 5.5V		2		mV
V _{CCSEL}	V _{CC} Select Voltage	V _{SBY} or V _{AUX} present		4.40	4.60	V
V _{CCDES}	V _{CC} Deselect Voltage	V _{SBY} or V _{AUX} present	4.00	4.20		V
V _{HYST}	Hysteresis Voltage	V _{SBY} or V _{AUX} present; See Note 2		0.20		V
R _{SW}	V _{AUX} Switch Resistance			0.25	0.40	Ω
I _{RCC} I _{RSBY} I _{RAUX}	V _{CC} Reverse Leakage V _{SBY} Reverse Leakage V _{AUX} Reverse Leakage	One supply input taken to GND while the others remain at nominal voltage.		5	100	μA
I _{CC}	V _{CC} Supply Current	V _{CC} > V _{CCSEL} , I _{LOAD} = 0mA		0.8	1.5	mA
I _{SBY}	V _{SBY} Supply Current	V _{CC} < V _{CCSEL} , I _{LOAD} = 0mA		0.8	1.5	mA
I _{AUX}	V _{AUX} Supply Current	V _{AUX} is selected, I _{LOAD} = 0mA		0.20	0.30	mA
I _{GND}	Ground Current	V _{AUX} is selected, (V _{CC/SBY} = 0V) V _{CC/SBY} = 5V, I _{LOAD} = 0mA V _{CC/SBY} = 5V, I _{LOAD} = 400mA		0.20 0.80 1.00	0.30 1.50 2.00	mA mA mA
T _{DISABLE} T _{HYST}	Shutdown Temperature Thermal Hysteresis			160 20		°C °C

Note 1: Operating characteristics are over Standard Operating Conditions unless otherwise specified.

Note 2: The disturbance on V_{CC} during supply changeover should be kept below the hysteresis voltage to prevent any chatter. The source resistance on the V_{CC} supply should be kept to less than 0.3 ohms to ensure precise switching.



Performance Information

CMPWR330 Typical DC Characteristics (nominal conditions unless specified otherwise)

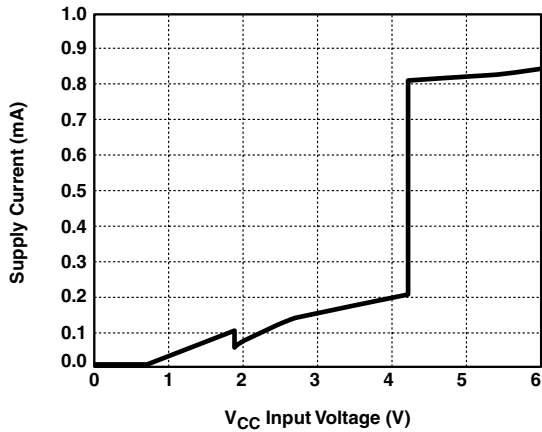

Figure 1. V_{CC} Supply Current vs Voltage

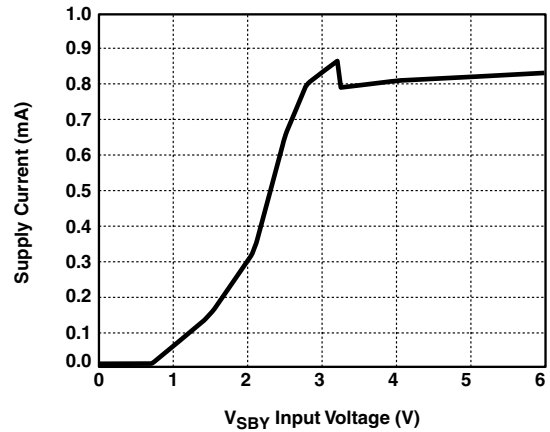

Figure 2. V_{SBY} Supply Current vs Voltage

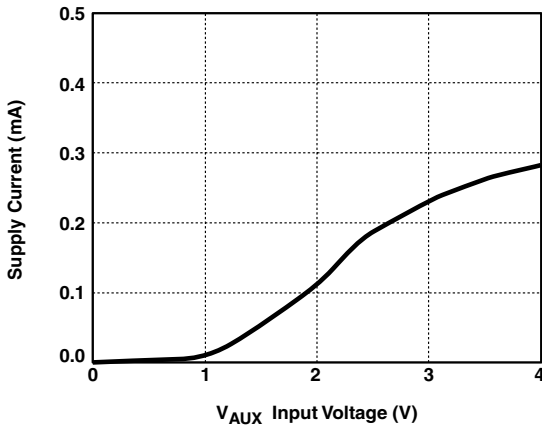

Figure 3. V_{AUX} Supply Current vs Voltage

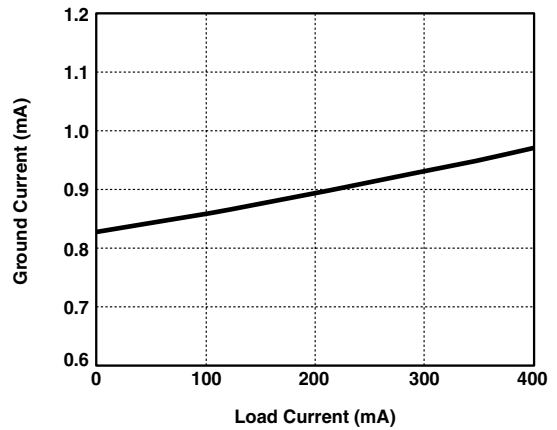
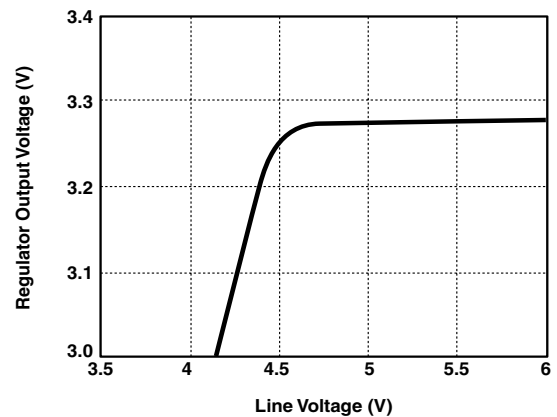
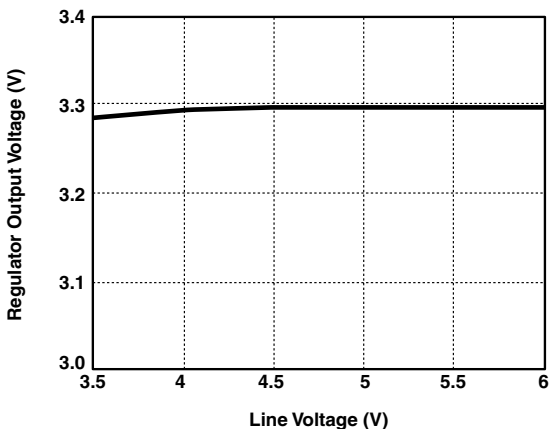

Figure 4. Ground Current vs Output Load





Performance Information (cont'd)

CMPWR330 Typical DC Characteristics (cont'd, nominal conditions unless specified otherwise)

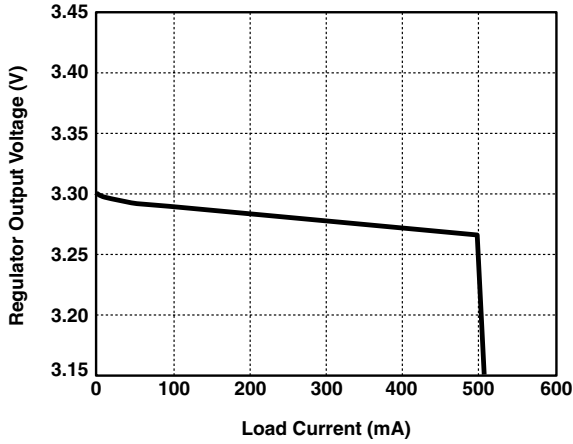

Figure 7. Load Regulation (5V Supply)

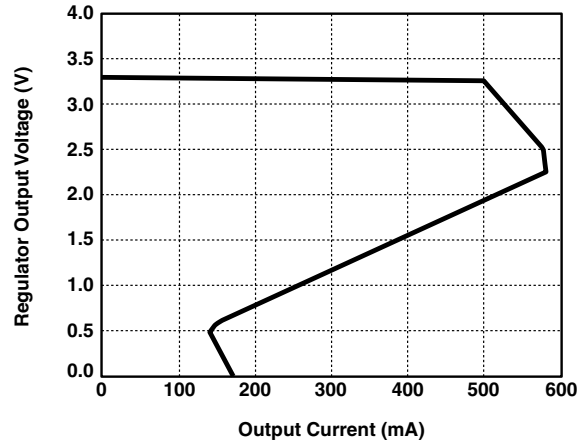

Figure 8. Foldback Current Limit Protection

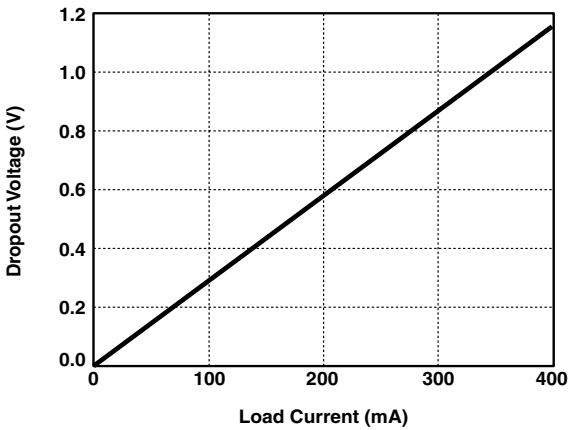

Figure 9. Regulator Dropout Characteristics

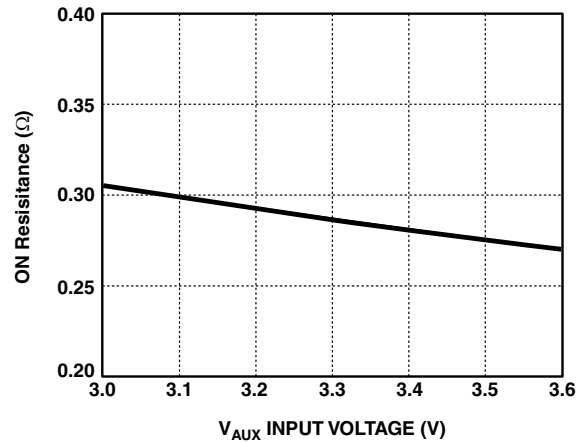

Figure 10. Switch Resistance vs V_{AUX} Supply

Performance Information (cont'd)

CMPWR330 Transient Characteristics (nominal conditions unless specified otherwise)
 (V_{CC} source resistance set to 0.2Ω)

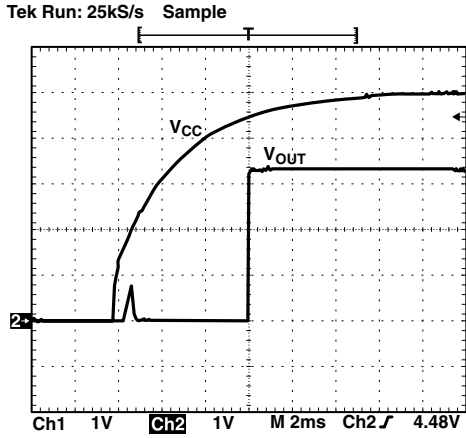

Figure 11. V_{CC} Cold Start (Load = 400mA)

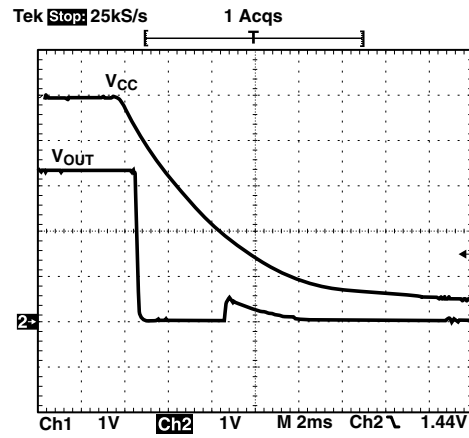

Figure 12. V_{CC} Full Power Down (Load = 400mA)

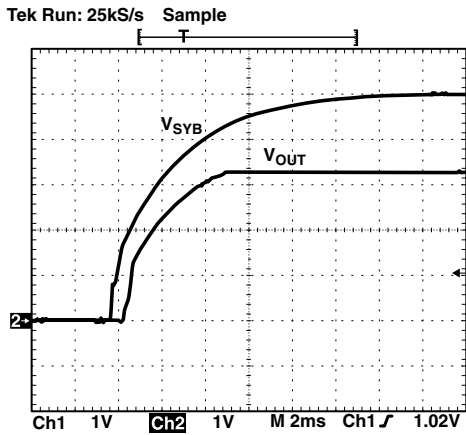

Figure 13. V_{SBY} Cold Start (Load = 400mA)

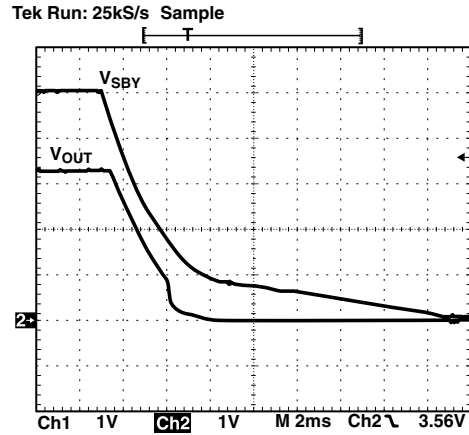

Figure 14. V_{SBY} Full Power Down (Load = 400mA)

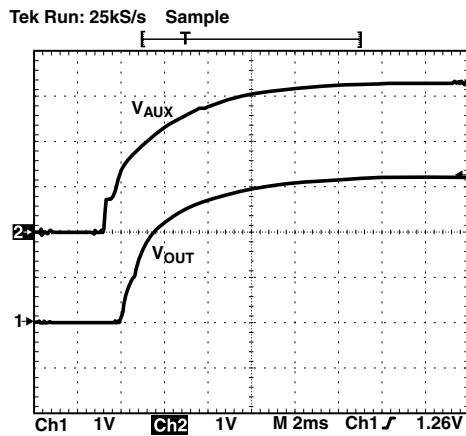

Figure 15. V_{AUX} Cold Start (Load = 400mA)

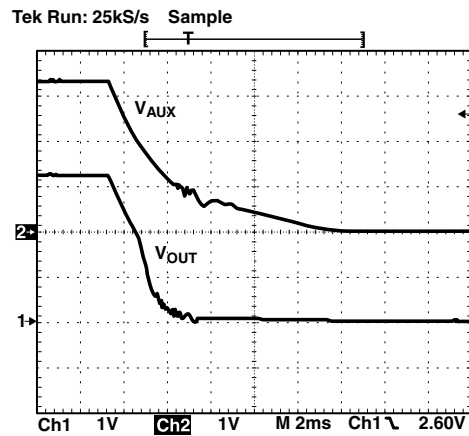

Figure 16. V_{AUX} Full Power Down (Load = 400mA)

Performance Information (cont'd)

CMPWR330 Transient Characteristics (cont'd; nominal conditions unless specified otherwise)
 (V_{CC} source resistance set to 0.2Ω)

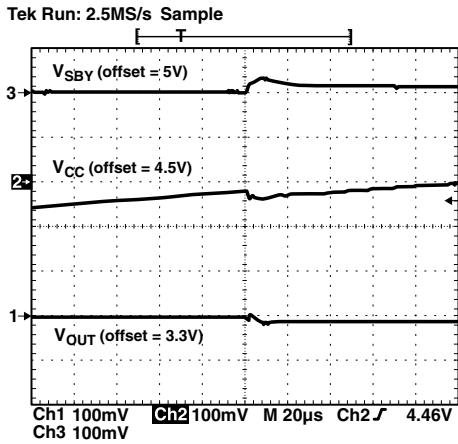

Figure 17. V_{CC} Power Up ($V_{SBY} = 5V$, Load = 300mA)

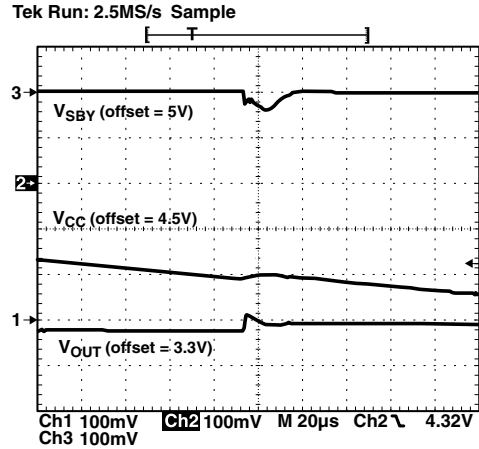

Figure 18. V_{CC} Power Down ($V_{SBY} = 5V$, Load = 300mA)

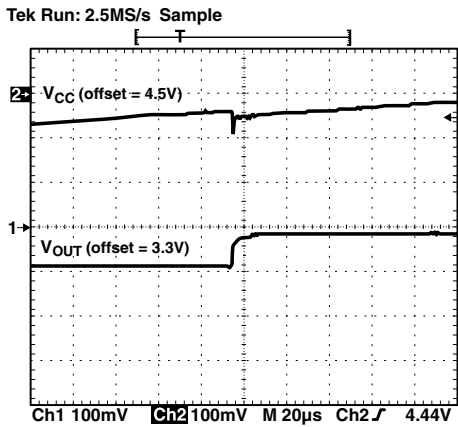

Figure 19. V_{CC} Power Up ($V_{AUX} = 3.3V$, Load = 300mA)

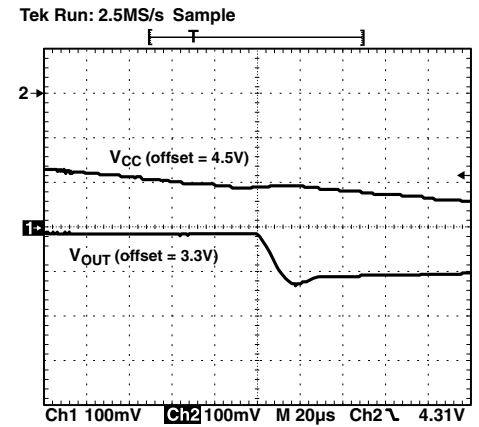

Figure 20. V_{CC} Power Down ($V_{AUX} = 3.3V$, Load = 300mA)

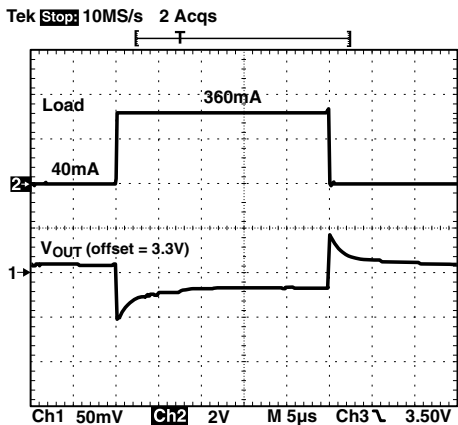

Figure 21. Load Transient Response (10% - 90% Rated)

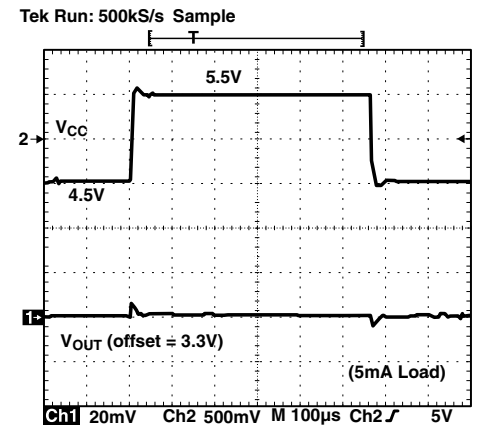

Figure 22. Line Transient ($1V_{pp}$) Response



Performance Information (cont'd)

CMPWR330 Typical Thermal Characteristics

The overall junction to ambient thermal resistance (θ_{JA}) for device power dissipation (P_D) consists primarily of two paths in series. The first path is the junction to the case (θ_{JC}) which is defined by the package style, and the second path is case to ambient (θ_{CA}) thermal resistance which is dependent on board layout. The final operating junction temperature for any set of conditions can be estimated by the following thermal equation:

$$T_J = T_A + (P_D)(\theta_{JC}) + (P_D)(\theta_{CA})$$

$$= T_A + (P_D)(\theta_{JA})$$

The CMPWR330 uses a thermally enhanced package where all the GND leads (pins 5 through 8) are integral to the leadframe. When this package is mounted on a double-sided printed circuit board with two square inches of copper allocated for "heat spreading", the resulting θ_{JA} is about 50°C/W.

Based on a typical operating power dissipation of 0.7W (1.75V x 0.4A) with an ambient of 70°C, the resulting junction temperature will be:

$$T_J = T_A + (P_D)(\theta_{JA})$$

$$= 70^\circ\text{C} + 0.7\text{W} \times (50^\circ\text{C}/\text{W})$$

$$= 70^\circ\text{C} + 35^\circ\text{C} = 105^\circ\text{C}$$

The thermal characteristics were measured using a double-sided board with two square inches of copper area connected to the GND pin for "heat spreading".

Measurements showing performance up to junction temperature of 125°C were performed under light load conditions (5mA). This allows the ambient temperature to be representative of the internal junction temperature.

Note: The use of multi-layer board construction with separate ground and power planes will further enhance the overall thermal performance. In the event of no copper area being dedicated for heat spreading, a multi-layer board construction, using only the minimum size pad layout, will provide the CMPWR330 with an overall θ_{JA} of 70°C/W which allows up to 780mW to be safely dissipated for the maximum junction temperature.

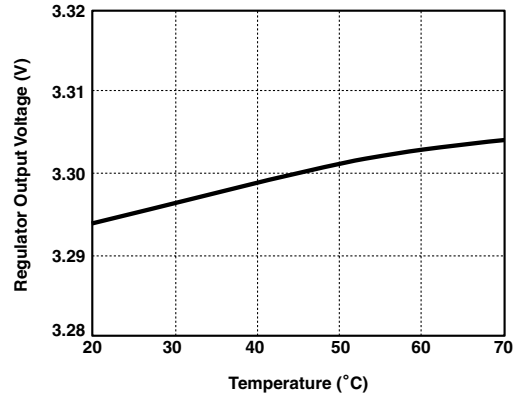

Figure 23. V_{OUT} Variation with T_{AMB} (400mA Load)_T

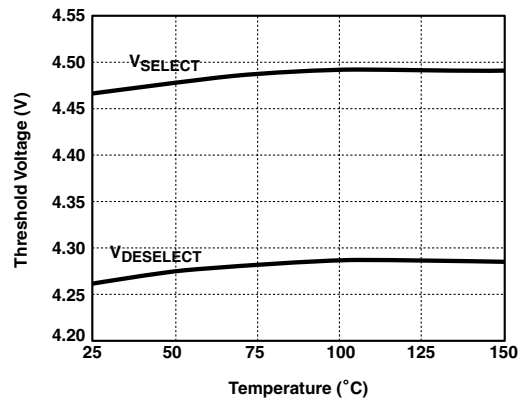

Figure 24. Select/Deselect Threshold Variation with T_{JUNC}

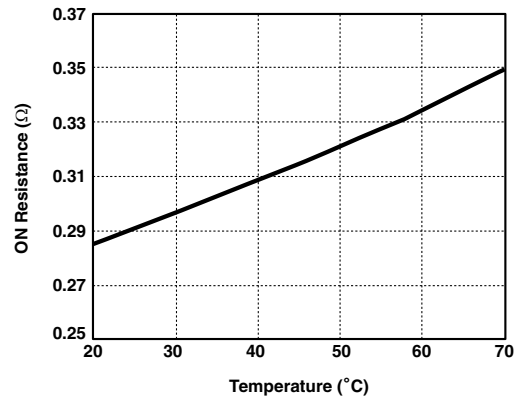

Figure 25. V_{AUX} Switch Resistance vs T_{AMB}



Mechanical Details

SOIC-8 Mechanical Specifications

Dimensions for CMPWR330 devices packaged in 8-pin SOIC packages are presented below.

For complete information on the SOIC-8 package, see the California Micro Devices SOIC Package Information document.

PACKAGE DIMENSIONS				
Package	SOIC			
Pins	8			
Dimensions	Millimeters		Inches	
	Min	Max	Min	Max
A	1.35	1.75	0.053	0.069
A ₁	0.10	0.25	0.004	0.010
B	0.33	0.51	0.013	0.020
C	0.19	0.25	0.007	0.010
D	4.80	5.00	0.189	0.197
E	3.80	4.19	0.150	0.165
e	1.27 BSC		0.050 BSC	
H	5.80	6.20	0.228	0.244
L	0.40	1.27	0.016	0.050
# per tube	100 pieces*			
# per tape and reel	2500 pieces			
Controlling dimension: inches				

* This is an approximate number which may vary.

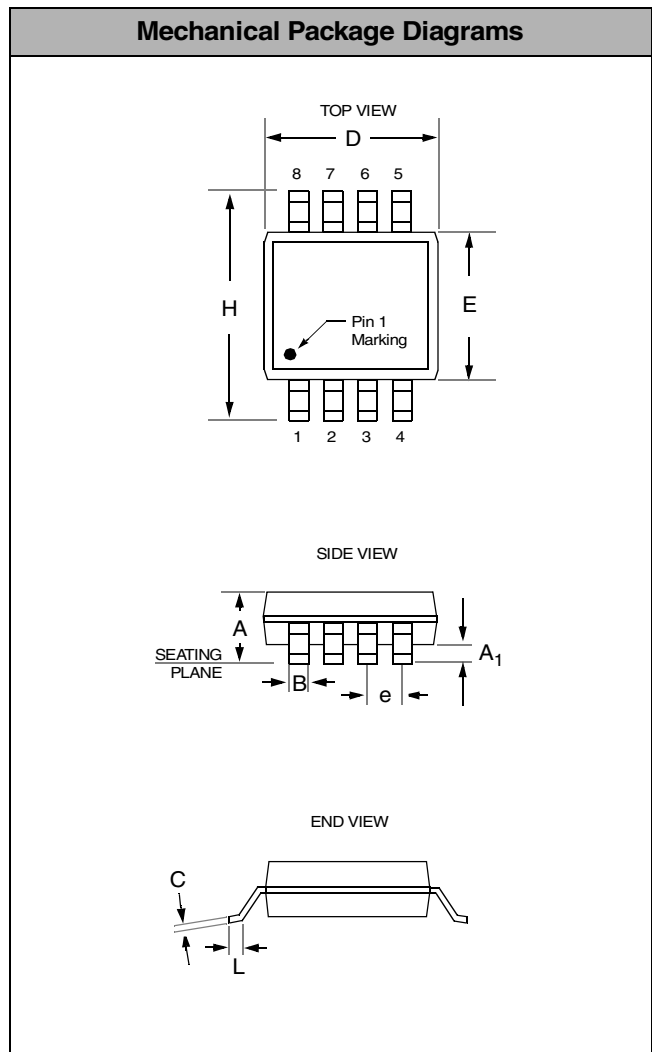

Package Dimensions for SOIC-8