

Features

- S_{21} = 23 dB @ 1920 MHz
= 21 dB @ 2170 MHz
- NF of 0.95 dB over Frequency
- Unconditionally Stable
- Single 5V Supply
- High OIP3 at Low Current

Description

The plerow™ ALN-series is the compactly designed surface-mount module for the use of the LNA with or without the following gain blocks in the infrastructure equipment of the mobile wireless (CDMA, GSM, PCS, PHS, WCDMA, DMB, WLAN, WiBro, WiMAX), GPS, satellite communication terminals, CATV and so on. It has an exceptional performance of low noise figure, high gain, high OIP3, and low bias current. The stability factor is always kept more than unity over the application band in order to ensure its unconditionally stable implementation to the application system environment. The surface-mount module package including the completed matching circuit and other components necessary just in case allows very simple and convenient implementation onto the system board in mass production level.

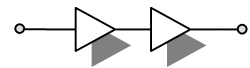

2-stage Single Type

Specifications (in Production)

Typ. @ T = 25°C, V_s = 5 V, Freq. = 2045 MHz, $Z_{o,sys}$ = 50 ohm

Parameter	Unit	Specifications		
		Min	Typ	Max
Frequency Range	MHz	1920		2170
Gain	dB	21	22	
Gain Flatness	dB		± 1.0	± 1.2
Noise Figure	dB		0.95	1.0
Output IP3 ⁽¹⁾	dBm	36	38	
S11 / S22 ⁽²⁾	dB			-18 / -10
Output P1dB	dBm	20	21	
Switching Time ⁽³⁾	μsec		-	
Supply Current	mA		110	140
Supply Voltage	V		5	
Impedance	Ω		50	
Max. RF Input Power	dBm	C.W 23 ~ 25 (before fail)		
Package Type & Size	mm	Surface Mount Type, 10Wx10Lx3.8H		

Operating temperature is -40°C to +85°C.

1) OIP3 is measured with two tones at an output power of 7 dBm / tone separated by 1 MHz.

2) S11/S22 (max) is the worst value within the frequency band.

3) Switching time means the time that takes for output power to get stabilized to its final level after switching DC voltage from 0 V to V_s .

More Information

Website: www.asb.co.kr
E-mail: sales@asb.co.kr

Tel: (82) 42-528-7223
Fax: (82) 42-528-7222

ASB Inc., 4th Fl. Venture Town Bldg., 367-17 Goijeong-Dong, Seo-Gu, Daejeon 302-716, Korea

Outline Drawing (Unit: mm)

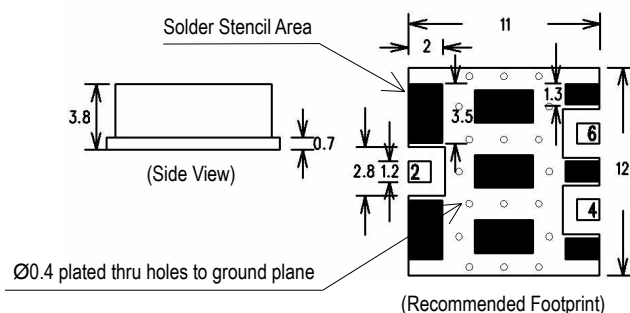
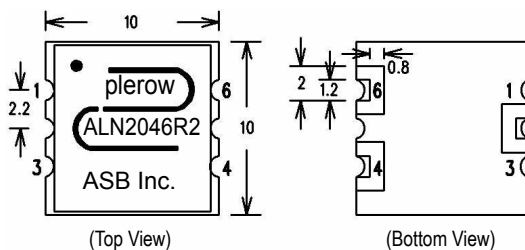

Pin Number	Function
2	RF In
4	+Vcc
6	RF Out
Others	Ground

Note: 1. The number and size of ground via holes in a circuit board is critical for thermal RF grounding considerations.

2. We recommend that the ground via holes be placed on the bottom of all ground pins for better RF and thermal performance, as shown in the drawing at the left side.

**Typical Performance
(Measured)**

1920~2170

+5 V

S-parameters

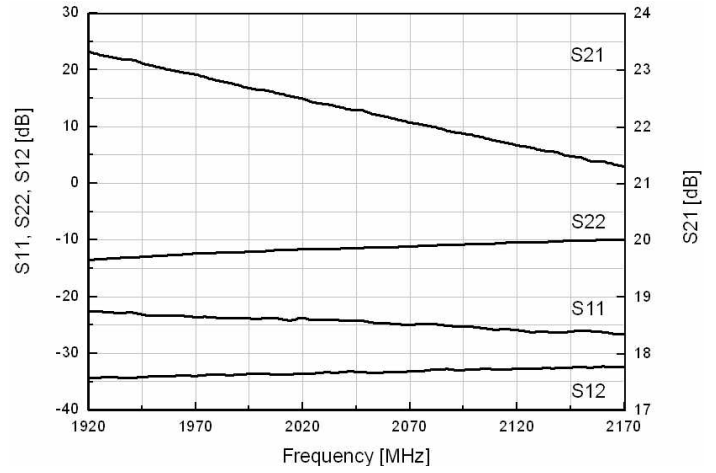

S-parameters & K Factor

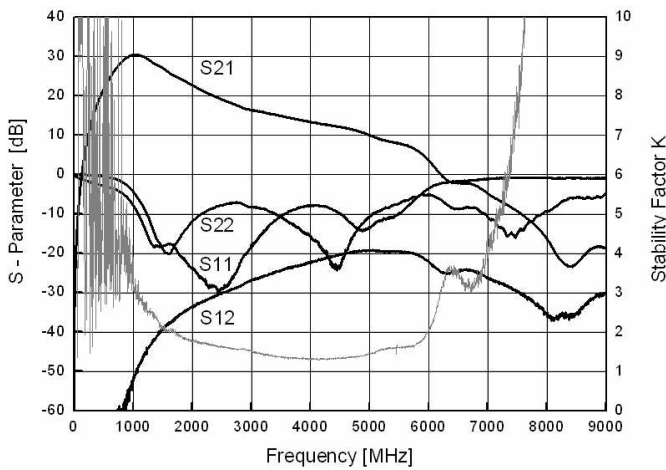

Noise Figure

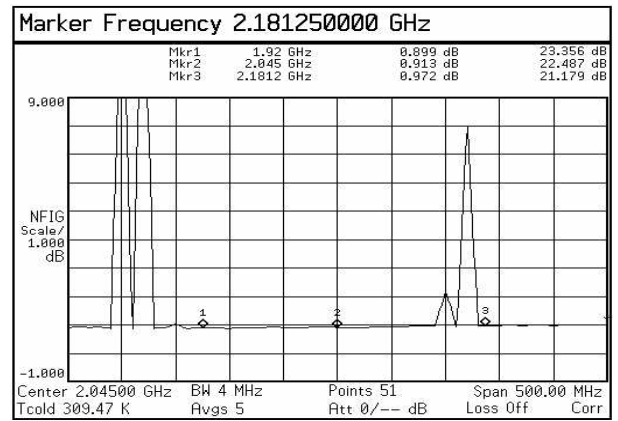

OIP3

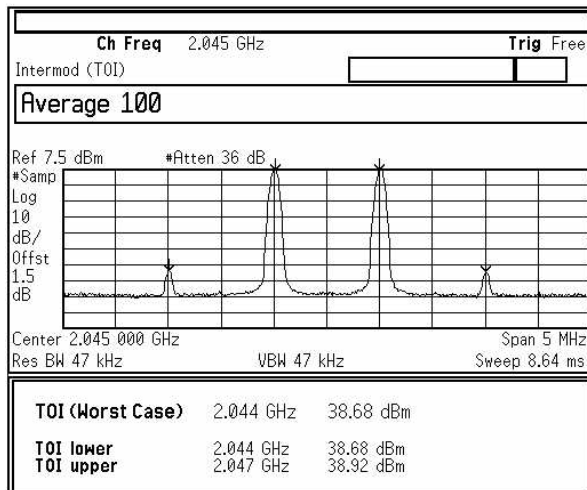

P1dB

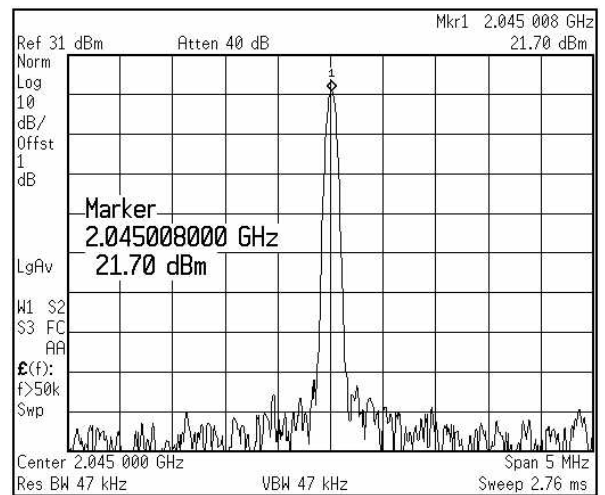

RF Performance with Voltage Change

Item Voltage	S11 (dB)	S22 (dB)	S21 (dB)	G/F (dB)	NF (dB)	P1dB (dBm)	OIP3 (dBm)	Current (mA)
4.5	-20.59	-10.17	21.99	1.97	0.964	21.33	34.00	72
4.6	-21.20	-10.18	22.09	1.98	0.965	21.53	35.05	78
4.7	-21.75	-10.20	22.18	1.98	0.967	21.71	36.01	85
4.8	-22.23	-10.22	22.25	1.87	0.970	21.89	36.97	92
4.9	-22.74	-10.22	22.31	1.98	0.972	22.06	37.68	99
5.0	-23.17	-10.24	22.35	1.98	0.975	22.21	38.33	107
5.1	-23.49	-10.19	22.39	1.98	0.989	22.35	38.98	114
5.2	-23.78	-10.17	22.42	1.99	1.013	22.51	39.21	121
5.3	-24.05	-10.14	22.44	1.98	1.031	22.62	39.30	128
5.4	-24.25	-10.12	22.45	1.98	1.054	22.77	39.40	135
5.5	-24.42	-10.09	22.45	1.98	1.066	22.91	39.64	142

RF Performance with Operating Temperature

Item Temp.	S11 (dB)	S22 (dB)	S21 (dB)	G/F (dB)	NF (dB)	P1dB (dBm)	OIP3 (dBm)	Current (mA)
-40°C	-19.95	-9.61	22.71	1.94	0.673	22.37	37.34	91
-20°C	-20.27	-9.57	22.85	1.98	0.758	22.27	37.58	94
0°C	-20.69	-9.44	22.47	1.97	0.858	22.19	37.90	98
25°C	-21.29	-9.31	22.28	1.98	0.935	21.95	38.04	101
40°C	-21.32	-9.18	22.28	1.99	1.036	21.79	38.15	103
60°C	-21.54	-9.04	22.14	2.00	1.117	21.45	37.96	105
80°C	-21.61	-9.12	22.03	1.98	1.226	21.23	37.75	106
100°C	-21.81	-9.09	21.80	2.00	1.355	21.01	36.22	105

**Typical Performance
(Measured)**

1950 ± 10 MHz

+5 V

S-parameters

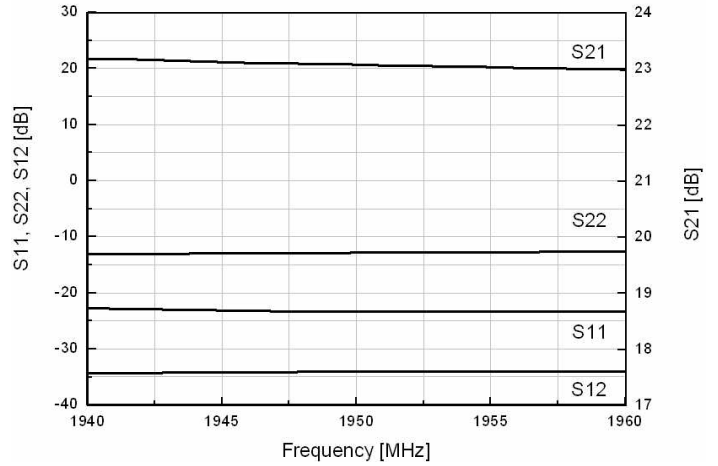

Stability Factor (K)

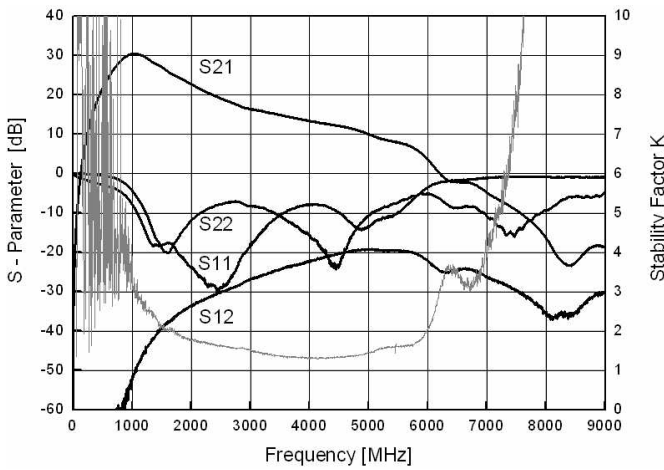

Noise Figure

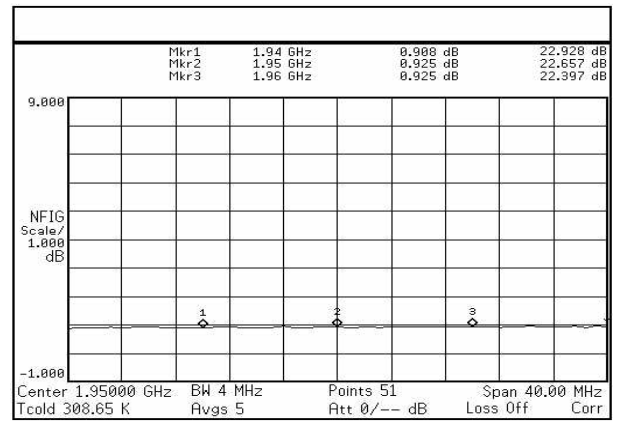

OIP3

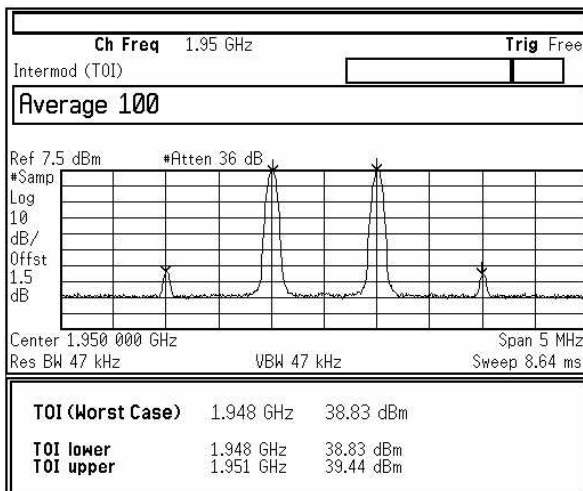

P1dB

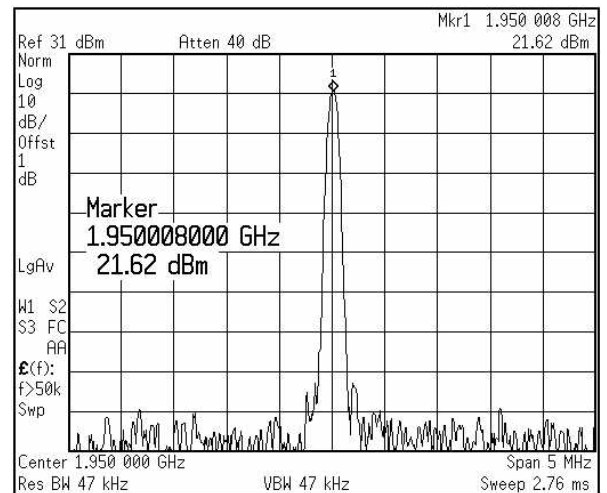

RF Performance with Voltage Change

Item Voltage	S11 (dB)	S22 (dB)	S21 (dB)	G/F (dB)	NF (dB)	P1dB (dBm)	OIP3 (dBm)	Current (mA)
4.5	-20.45	-12.64	22.72	0.17	0.902	21.27	34.02	72
4.6	-21.06	-12.66	22.84	0.17	0.906	21.48	35.08	78
4.7	-21.70	-12.71	22.92	1.17	0.909	21.67	36.12	85
4.8	-22.22	-12.70	23.00	1.18	0.914	21.86	37.02	92
4.9	-22.67	-12.74	23.06	0.17	0.918	22.01	37.80	99
5.0	-23.06	-12.74	23.10	0.18	0.924	22.16	38.43	107
5.1	-23.45	-12.74	23.15	0.18	0.929	22.32	38.92	114
5.2	-23.70	-12.67	23.18	0.17	0.936	22.47	39.15	121
5.3	-24.01	-12.62	23.19	0.18	0.941	22.63	39.32	128
5.4	-24.20	-12.57	23.21	0.18	0.947	22.77	39.41	135
5.5	-24.38	-12.55	23.21	0.18	0.954	22.86	39.50	142

RF Performance with Operating Temperature

Item Temp.	S11 (dB)	S22 (dB)	S21 (dB)	G/F (dB)	NF (dB)	P1dB (dBm)	OIP3 (dBm)	Current (mA)
-40°C	-19.81	-11.51	23.50	0.17	0.689	22.18	37.28	91
-20°C	-20.20	-11.53	23.36	0.16	0.757	22.11	37.75	94
0°C	-20.64	-11.44	23.26	0.16	0.844	22.03	38.09	98
25°C	-21.01	-11.30	23.09	0.17	0.928	21.88	38.15	101
40°C	-21.15	-11.17	23.07	0.17	0.999	21.67	38.07	103
60°C	-21.40	-11.04	22.93	0.18	1.095	21.41	37.83	105
80°C	-21.14	-11.11	22.82	0.18	1.194	21.21	37.76	106
100°C	-21.18	-11.07	22.57	0.19	1.326	21.08	36.18	105

**Typical Performance
(Measured)**

2140 ± 10 MHz
+5 V

S-parameters

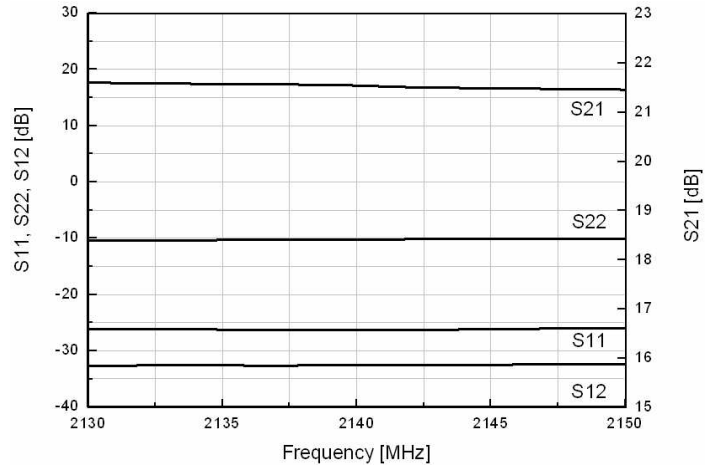

Stability Factor (K)

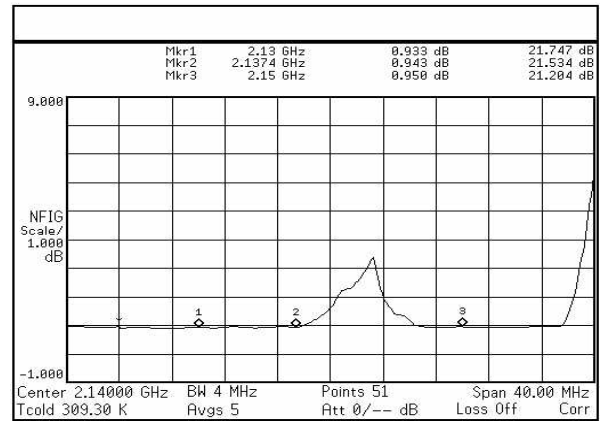
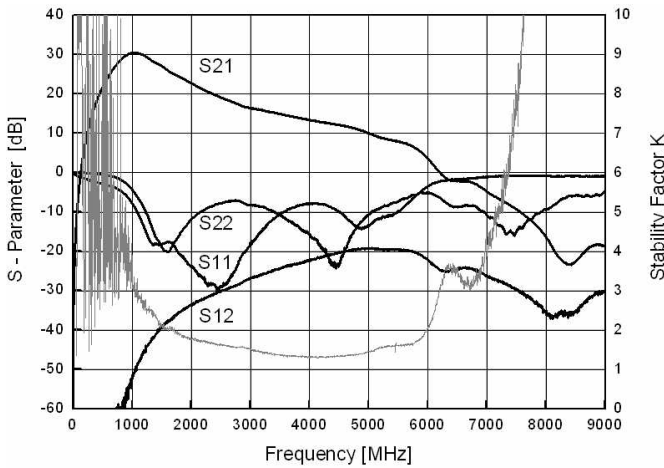

OIP3

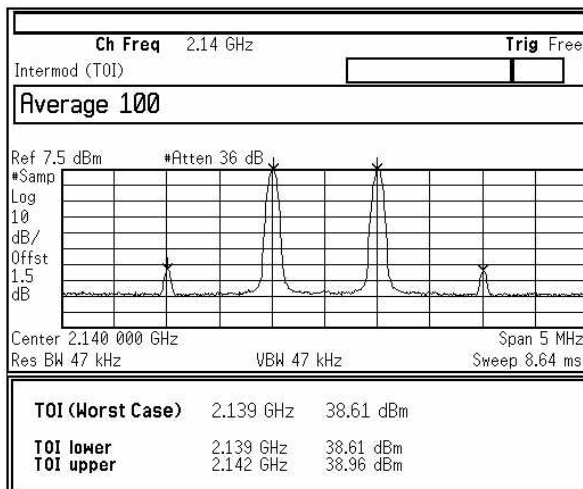

P1dB

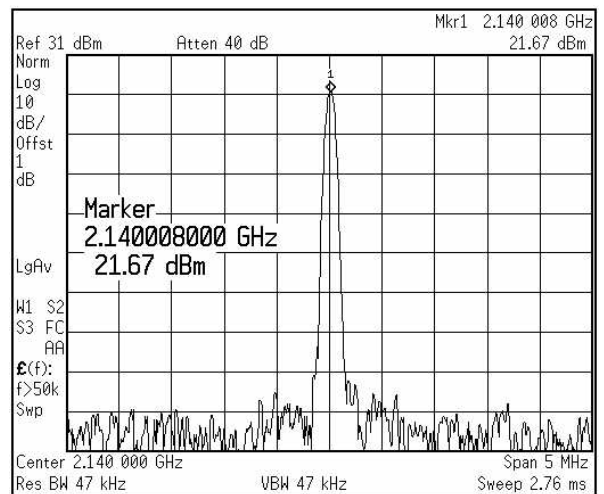

RF Performance with Voltage Change

Item Voltage	S11 (dB)	S22 (dB)	S21 (dB)	G/F (dB)	NF (dB)	P1dB (dBm)	OIP3 (dBm)	Current (mA)
4.5	-22.08	-10.38	21.24	0.18	0.922	21.37	34.45	72
4.6	-22.94	-10.37	21.34	0.18	0.928	21.58	35.45	78
4.7	-23.62	-10.40	21.42	0.18	0.935	21.74	36.42	85
4.8	-24.35	-10.40	21.50	0.19	0.940	21.92	37.32	92
4.9	-25.01	-10.42	21.55	0.18	0.946	22.06	38.05	99
5.0	-25.55	-10.43	21.59	0.18	0.953	22.23	38.53	107
5.1	-26.08	-10.43	21.63	0.18	0.964	22.38	38.97	114
5.2	-26.74	-10.36	21.65	0.18	0.972	22.51	39.24	121
5.3	-27.11	-10.34	21.67	0.19	0.985	22.64	39.37	128
5.4	-27.53	-10.32	21.68	0.18	0.998	22.76	39.54	135
5.5	-27.67	-10.27	21.68	0.18	1.017	22.88	39.68	142

RF Performance with Operating Temperature

Item Temp.	S11 (dB)	S22 (dB)	S21 (dB)	G/F (dB)	NF (dB)	P1dB (dBm)	OIP3 (dBm)	Current (mA)
-40°C	-20.05	-9.82	21.97	0.18	0.689	22.52	37.39	91
-20°C	-20.31	-9.62	21.84	0.18	0.763	22.35	37.80	94
0°C	-20.59	-9.48	21.74	0.19	0.871	22.26	37.98	98
25°C	-21.41	-9.37	21.54	0.18	0.944	22.11	38.02	101
40°C	-21.47	-9.22	21.53	0.19	1.031	21.87	38.05	103
60°C	-21.70	-9.10	21.39	0.19	1.130	21.60	37.78	105
80°C	-21.85	-9.08	21.29	0.18	1.242	21.33	37.54	106
100°C	-22.07	-9.07	21.04	0.17	1.382	21.09	36.15	105

Application Circuit

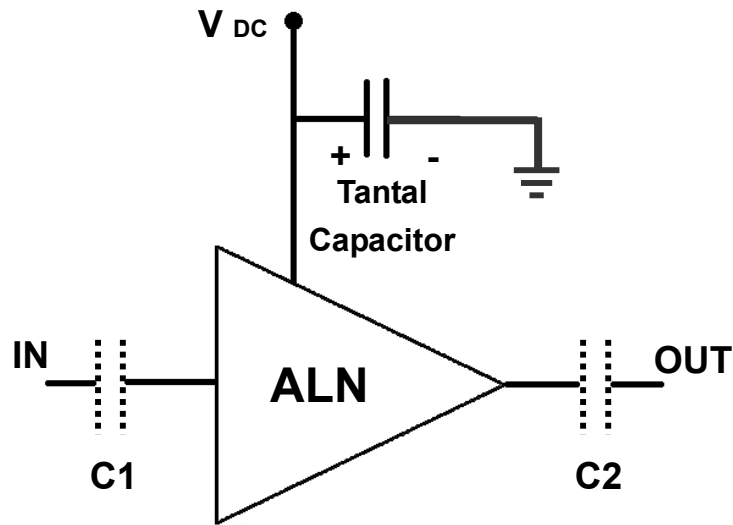

- 1) The tantal capacitor is optional and for bypassing the AC noise introduced from the DC supply. The capacitance value may be determined by customer's DC supply status.
- 2) So-called DC blocking capacitors are always necessarily placed at the input and output port for allowing only the RF signal to pass and blocking the DC component in the signal. The DC blocking capacitors are included inside the LNA module. Therefore, C1 & C2 capacitors may not be necessary, but can be added just in case that the customer wants. The value of C1 & C2 is determined by considering the application frequency.

Recommended Soldering Reflow Process

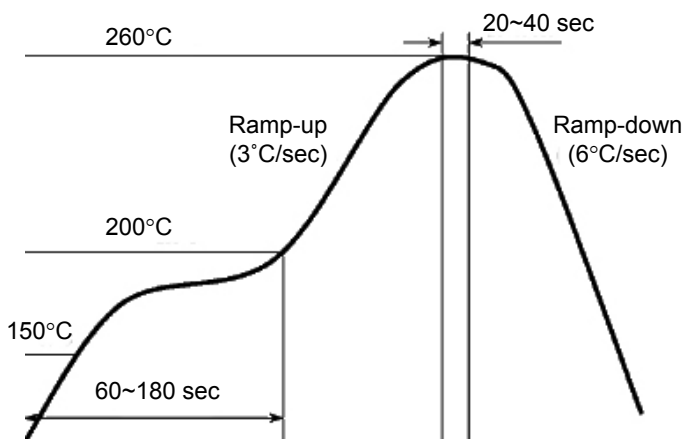

Evaluation Board Layout

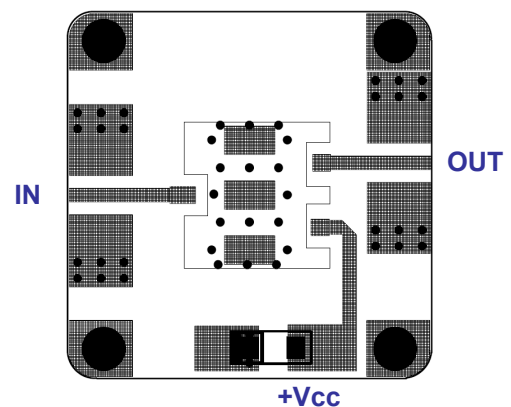

Size 25 x 25mm
(for ALN-R Series – 10x10mm)